



Full wwPDB X-ray Structure Validation Report ⓘ

Apr 5, 2022 – 04:24 pm BST

PDB ID : 7BH8
Title : 3H4-Fab HLA-E-VL9 co-complex
Authors : Walters, L.C.; Rozbesky, D.
Deposited on : 2021-01-10
Resolution : 1.80 Å(reported)

This is a Full wwPDB X-ray Structure Validation Report for a publicly released PDB entry.

We welcome your comments at validation@mail.wwpdb.org

A user guide is available at

<https://www.wwpdb.org/validation/2017/XrayValidationReportHelp>

with specific help available everywhere you see the ⓘ symbol.

The following versions of software and data (see [references ⓘ](#)) were used in the production of this report:

MolProbity : 4.02b-467
Mogul : 1.8.4, CSD as541be (2020)
Xtriage (Phenix) : 1.13
EDS : 2.27
Percentile statistics : 20191225.v01 (using entries in the PDB archive December 25th 2019)
Refmac : 5.8.0267
CCP4 : 7.1.010 (Gargrove)
Ideal geometry (proteins) : Engh & Huber (2001)
Ideal geometry (DNA, RNA) : Parkinson et al. (1996)
Validation Pipeline (wwPDB-VP) : 2.27

1 Overall quality at a glance

The following experimental techniques were used to determine the structure:

X-RAY DIFFRACTION

The reported resolution of this entry is 1.80 Å.

Percentile scores (ranging between 0-100) for global validation metrics of the entry are shown in the following graphic. The table shows the number of entries on which the scores are based.

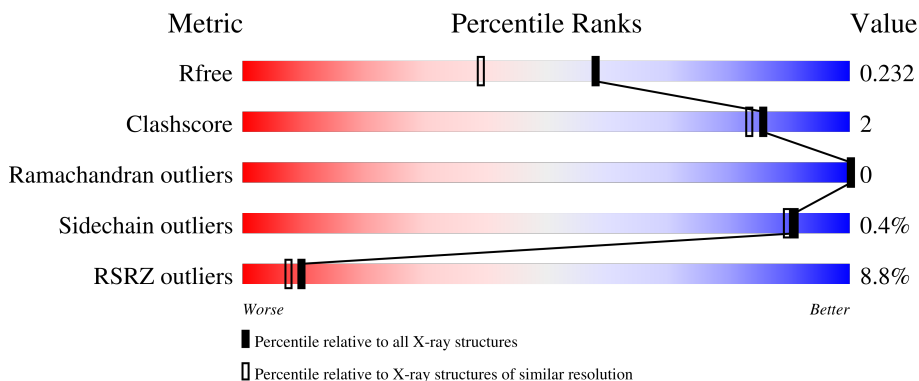

Metric	Whole archive (#Entries)	Similar resolution (#Entries, resolution range(Å))
R_{free}	130704	5950 (1.80-1.80)
Clashscore	141614	6793 (1.80-1.80)
Ramachandran outliers	138981	6697 (1.80-1.80)
Sidechain outliers	138945	6696 (1.80-1.80)
RSRZ outliers	127900	5850 (1.80-1.80)

The table below summarises the geometric issues observed across the polymeric chains and their fit to the electron density. The red, orange, yellow and green segments of the lower bar indicate the fraction of residues that contain outliers for ≥ 3 , 2, 1 and 0 types of geometric quality criteria respectively. A grey segment represents the fraction of residues that are not modelled. The numeric value for each fraction is indicated below the corresponding segment, with a dot representing fractions $\leq 5\%$. The upper red bar (where present) indicates the fraction of residues that have poor fit to the electron density. The numeric value is given above the bar.

Mol	Chain	Length	Quality of chain
1	A	276	
1	C	276	
2	B	100	
2	D	100	
3	E	244	

Continued on next page...

Continued from previous page...

Mol	Chain	Length	Quality of chain
3	G	244	 89% 8%
4	F	233	 % 87% 5% 8%
4	H	233	 90% 8%
5	P	9	 100%
5	Q	9	 89% 11%

2 Entry composition i

There are 8 unique types of molecules in this entry. The entry contains 14072 atoms, of which 0 are hydrogens and 0 are deuteriums.

In the tables below, the ZeroOcc column contains the number of atoms modelled with zero occupancy, the AltConf column contains the number of residues with at least one atom in alternate conformation and the Trace column contains the number of residues modelled with at most 2 atoms.

- Molecule 1 is a protein called HLA class I histocompatibility antigen, alpha chain E.

Mol	Chain	Residues	Atoms					ZeroOcc	AltConf	Trace
			Total	C	N	O	S			
1	A	276	Total	C	N	O	S	0	0	0
			2246	1405	402	432	7			
1	C	261	Total	C	N	O	S	0	0	0
			2127	1333	378	409	7			

- Molecule 2 is a protein called Beta-2-microglobulin.

Mol	Chain	Residues	Atoms					ZeroOcc	AltConf	Trace
			Total	C	N	O	S			
2	B	100	Total	C	N	O	S	0	0	0
			837	533	141	159	4			
2	D	98	Total	C	N	O	S	0	0	0
			820	524	139	154	3			

There are 2 discrepancies between the modelled and reference sequences:

Chain	Residue	Modelled	Actual	Comment	Reference
B	1	MET	-	initiating methionine	UNP P61769
D	1	MET	-	initiating methionine	UNP P61769

- Molecule 3 is a protein called 3H4 Fab heavy chain.

Mol	Chain	Residues	Atoms					ZeroOcc	AltConf	Trace
			Total	C	N	O	S			
3	G	225	Total	C	N	O	S	0	0	0
			1696	1074	274	342	6			
3	E	218	Total	C	N	O	S	0	0	0
			1649	1047	265	331	6			

- Molecule 4 is a protein called 3H4 Fab light chain.

Mol	Chain	Residues	Atoms					ZeroOcc	AltConf	Trace
			Total	C	N	O	S			
4	H	214	Total	C	N	O	S	0	0	0
			1663	1045	274	337	7			

Continued on next page...

Continued from previous page...

Mol	Chain	Residues	Atoms					ZeroOcc	AltConf	Trace
			Total	C	N	O	S			
4	F	214	Total 1663	C 1045	N 274	O 337	S 7	0	0	0

- Molecule 5 is a protein called VL9 leader peptide.

Mol	Chain	Residues	Atoms					ZeroOcc	AltConf	Trace
			Total	C	N	O	S			
5	P	9	Total 69	C 45	N 12	O 11	S 1	0	0	0
5	Q	9	Total 69	C 45	N 12	O 11	S 1	0	0	0

- Molecule 6 is GLYCEROL (three-letter code: GOL) (formula: C₃H₈O₃).

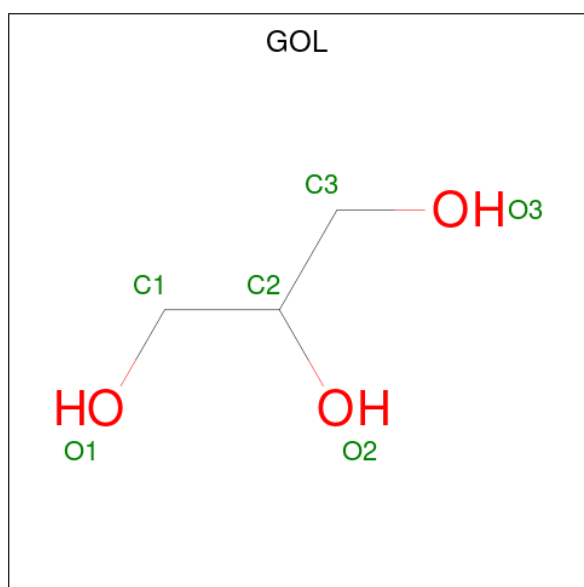

Mol	Chain	Residues	Atoms			ZeroOcc	AltConf
			Total	C	O		
6	A	1	Total 6	C 3	O 3	0	0
6	A	1	Total 6	C 3	O 3	0	0
6	A	1	Total 6	C 3	O 3	0	0
6	B	1	Total 6	C 3	O 3	0	0
6	B	1	Total 6	C 3	O 3	0	0
6	C	1	Total 6	C 3	O 3	0	0

Continued on next page...

Continued from previous page...

Mol	Chain	Residues	Atoms			ZeroOcc	AltConf
6	G	1	Total	C	O	0	0
			6	3	3		
6	H	1	Total	C	O	0	0
			6	3	3		
6	H	1	Total	C	O	0	0
			6	3	3		
6	F	1	Total	C	O	0	0
			6	3	3		

- Molecule 7 is CALCIUM ION (three-letter code: CA) (formula: Ca).

Mol	Chain	Residues	Atoms		ZeroOcc	AltConf
7	G	1	Total	Ca	0	0
			1	1		

- Molecule 8 is water.

Mol	Chain	Residues	Atoms		ZeroOcc	AltConf
8	A	251	Total	O	0	0
			251	251		
8	B	94	Total	O	0	0
			94	94		
8	C	67	Total	O	0	0
			67	67		
8	D	7	Total	O	0	0
			7	7		
8	G	230	Total	O	0	0
			230	230		
8	H	222	Total	O	0	0
			222	222		
8	E	106	Total	O	0	0
			106	106		
8	F	189	Total	O	0	0
			189	189		
8	P	3	Total	O	0	0
			3	3		
8	Q	3	Total	O	0	0
			3	3		

3 Residue-property plots [i](#)

These plots are drawn for all protein, RNA, DNA and oligosaccharide chains in the entry. The first graphic for a chain summarises the proportions of the various outlier classes displayed in the second graphic. The second graphic shows the sequence view annotated by issues in geometry and electron density. Residues are color-coded according to the number of geometric quality criteria for which they contain at least one outlier: green = 0, yellow = 1, orange = 2 and red = 3 or more. A red dot above a residue indicates a poor fit to the electron density ($RSRZ > 2$). Stretches of 2 or more consecutive residues without any outlier are shown as a green connector. Residues present in the sample, but not in the model, are shown in grey.

- Molecule 1: HLA class I histocompatibility antigen, alpha chain E



- Molecule 1: HLA class I histocompatibility antigen, alpha chain E

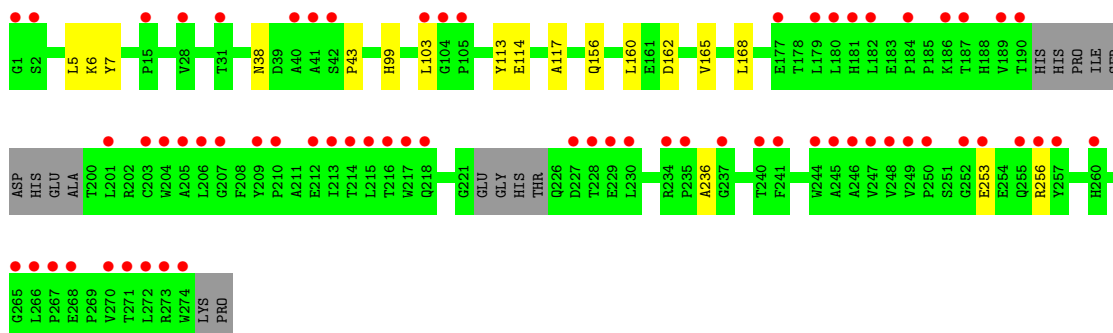
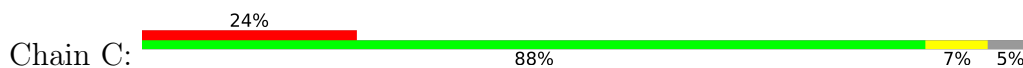

- Molecule 2: Beta-2-microglobulin

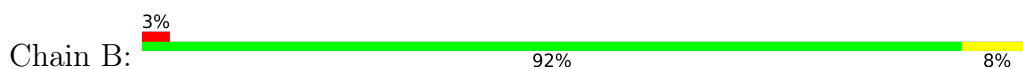

- Molecule 2: Beta-2-microglobulin

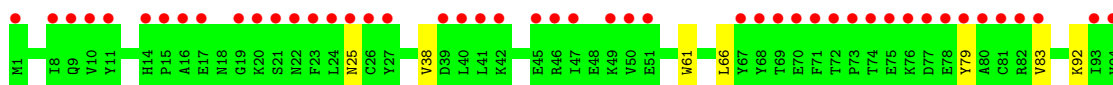
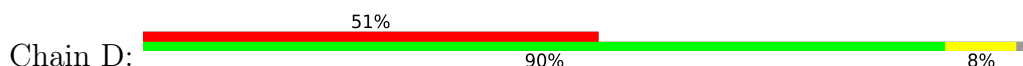

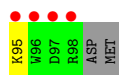

- Molecule 3: 3H4 Fab heavy chain

Chain G: 89% 8%



- Molecule 3: 3H4 Fab heavy chain

Chain E: 4% 82% 7% 11%

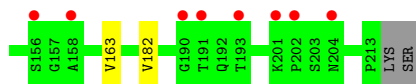
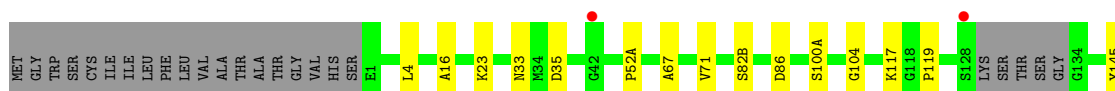

- Molecule 4: 3H4 Fab light chain

Chain H: 90% 8%

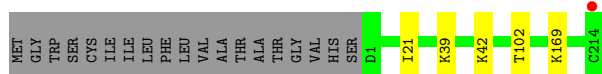

- Molecule 4: 3H4 Fab light chain

Chain F: % 87% 5% 8%

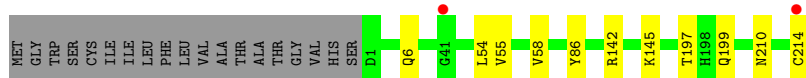

- Molecule 5: VL9 leader peptide

Chain P: 100%

There are no outlier residues recorded for this chain.

- Molecule 5: VL9 leader peptide

Chain Q: 89% 11%



4 Data and refinement statistics i

Property	Value	Source
Space group	C 1 2 1	Depositor
Cell constants a, b, c, α , β , γ	190.43Å 73.69Å 159.73Å 90.00° 101.63° 90.00°	Depositor
Resolution (Å)	54.74 – 1.80 54.74 – 1.80	Depositor EDS
% Data completeness (in resolution range)	98.1 (54.74-1.80) 98.1 (54.74-1.80)	Depositor EDS
R_{merge}	0.06	Depositor
R_{sym}	(Not available)	Depositor
$\langle I/\sigma(I) \rangle$ ¹	1.04 (at 1.80Å)	Xtrriage
Refinement program	PHENIX 1.18.2_3874, PHENIX 1.18.2_3874	Depositor
R, R_{free}	0.195 , 0.232 0.195 , 0.232	Depositor DCC
R_{free} test set	9848 reflections (5.00%)	wwPDB-VP
Wilson B-factor (Å ²)	36.0	Xtrriage
Anisotropy	0.377	Xtrriage
Bulk solvent k_{sol} (e/Å ³), B_{sol} (Å ²)	(Not available) , (Not available)	EDS
L-test for twinning ²	$\langle L \rangle = 0.49$, $\langle L^2 \rangle = 0.33$	Xtrriage
Estimated twinning fraction	No twinning to report.	Xtrriage
F_o, F_c correlation	0.97	EDS
Total number of atoms	14072	wwPDB-VP
Average B, all atoms (Å ²)	51.0	wwPDB-VP

Xtrriage's analysis on translational NCS is as follows: *The largest off-origin peak in the Patterson function is 3.01% of the height of the origin peak. No significant pseudotranslation is detected.*

¹Intensities estimated from amplitudes.

²Theoretical values of $\langle |L| \rangle$, $\langle L^2 \rangle$ for acentric reflections are 0.5, 0.333 respectively for untwinned datasets, and 0.375, 0.2 for perfectly twinned datasets.

5 Model quality

5.1 Standard geometry

Bond lengths and bond angles in the following residue types are not validated in this section: CA, GOL

The Z score for a bond length (or angle) is the number of standard deviations the observed value is removed from the expected value. A bond length (or angle) with $|Z| > 5$ is considered an outlier worth inspection. RMSZ is the root-mean-square of all Z scores of the bond lengths (or angles).

Mol	Chain	Bond lengths		Bond angles	
		RMSZ	# Z >5	RMSZ	# Z >5
1	A	0.33	0/2313	0.50	0/3146
1	C	0.26	0/2186	0.44	0/2969
2	B	0.30	0/860	0.51	0/1162
2	D	0.25	0/843	0.42	0/1141
3	E	0.29	0/1693	0.50	0/2311
3	G	0.33	0/1741	0.54	0/2375
4	F	0.31	0/1698	0.52	0/2301
4	H	0.35	0/1698	0.56	0/2301
5	P	0.31	0/69	0.55	0/92
5	Q	0.30	0/69	0.52	0/92
All	All	0.31	0/13170	0.50	0/17890

There are no bond length outliers.

There are no bond angle outliers.

There are no chirality outliers.

There are no planarity outliers.

5.2 Too-close contacts

In the following table, the Non-H and H(model) columns list the number of non-hydrogen atoms and hydrogen atoms in the chain respectively. The H(added) column lists the number of hydrogen atoms added and optimized by MolProbity. The Clashes column lists the number of clashes within the asymmetric unit, whereas Symm-Clashes lists symmetry-related clashes.

Mol	Chain	Non-H	H(model)	H(added)	Clashes	Symm-Clashes
1	A	2246	0	2088	13	0
1	C	2127	0	1984	11	0
2	B	837	0	803	4	0

Continued on next page...

Continued from previous page...

Mol	Chain	Non-H	H(model)	H(added)	Clashes	Symm-Clashes
2	D	820	0	790	6	0
3	E	1649	0	1594	12	0
3	G	1696	0	1646	3	0
4	F	1663	0	1618	7	0
4	H	1663	0	1618	3	0
5	P	69	0	83	0	0
5	Q	69	0	83	1	0
6	A	18	0	24	1	0
6	B	12	0	16	0	0
6	C	6	0	8	0	0
6	F	6	0	8	0	0
6	G	6	0	8	0	0
6	H	12	0	16	0	0
7	G	1	0	0	0	0
8	A	251	0	0	3	0
8	B	94	0	0	0	0
8	C	67	0	0	1	0
8	D	7	0	0	0	0
8	E	106	0	0	6	0
8	F	189	0	0	2	0
8	G	230	0	0	0	0
8	H	222	0	0	0	0
8	P	3	0	0	0	0
8	Q	3	0	0	0	0
All	All	14072	0	12387	56	0

The all-atom clashscore is defined as the number of clashes found per 1000 atoms (including hydrogen atoms). The all-atom clashscore for this structure is 2.

All (56) close contacts within the same asymmetric unit are listed below, sorted by their clash magnitude.

Atom-1	Atom-2	Interatomic distance (Å)	Clash overlap (Å)
1:C:114:GLU:OE2	1:C:156:GLN:NE2	2.06	0.87
3:E:16:ALA:O	8:E:301:HOH:O	1.93	0.85
1:A:266:LEU:O	8:A:501:HOH:O	2.09	0.69
1:A:106:ASP:OD2	8:A:502:HOH:O	2.11	0.69
1:A:232:GLU:OE2	8:A:503:HOH:O	2.11	0.68
3:E:82(B):SER:N	8:E:301:HOH:O	2.26	0.67
1:A:38:ASN:HA	1:A:43:PRO:HB3	1.76	0.67
3:E:67:ALA:O	8:E:302:HOH:O	2.13	0.64
3:E:23:LYS:O	8:E:303:HOH:O	2.16	0.58

Continued on next page...

Continued from previous page...

Atom-1	Atom-2	Interatomic distance (Å)	Clash overlap (Å)
4:H:21:ILE:HD12	4:H:102:THR:HG21	1.84	0.57
3:E:163:VAL:HG22	3:E:182:VAL:HG22	1.88	0.56
1:A:218:GLN:HG2	1:A:223:GLY:HA2	1.88	0.56
2:D:25:ASN:HB3	2:D:66:LEU:HD11	1.88	0.55
1:A:117:ALA:HB2	2:B:61:TRP:CE2	2.41	0.54
1:A:6:LYS:HE2	1:A:113:TYR:OH	2.08	0.53
1:C:117:ALA:HB2	2:D:61:TRP:CE2	2.44	0.52
4:F:6:GLN:NE2	4:F:86:TYR:O	2.41	0.52
3:G:12:VAL:HG21	3:G:82(C):LEU:HD12	1.92	0.51
1:A:114:GLU:OE2	1:A:156:GLN:NE2	2.38	0.51
4:F:55:VAL:O	4:F:58:VAL:HG12	2.10	0.51
1:C:162:ASP:OD2	8:C:401:HOH:O	2.19	0.51
3:G:4:LEU:HB2	3:G:104:GLY:HA2	1.91	0.51
1:A:38:ASN:HA	1:A:43:PRO:CB	2.42	0.50
1:A:111:ARG:HH12	6:A:403:GOL:H11	1.76	0.50
2:B:23:PHE:CE2	2:B:70:GLU:HG2	2.47	0.49
2:D:38:VAL:HG22	2:D:83:VAL:HG22	1.94	0.49
1:C:103:LEU:HD21	1:C:165:VAL:HG13	1.95	0.48
3:G:33:ASN:HA	3:G:52(A):PRO:HD3	1.96	0.47
1:A:127:ASN:ND2	1:A:132:SER:OG	2.46	0.46
4:F:54:LEU:HD23	4:F:58:VAL:HG13	1.97	0.46
3:E:33:ASN:HA	3:E:52(A):PRO:HD3	1.97	0.45
3:E:86:ASP:OD1	8:E:304:HOH:O	2.21	0.45
2:D:79:TYR:O	2:D:95:LYS:HD3	2.17	0.44
3:E:117:LYS:HE3	8:E:312:HOH:O	2.18	0.44
1:C:253:GLU:HG2	1:C:256:ARG:NH1	2.33	0.44
4:F:142:ARG:NH2	8:F:411:HOH:O	2.50	0.44
1:C:236:ALA:O	2:D:25:ASN:ND2	2.50	0.43
3:E:100(A):SER:HB2	5:Q:4:PRO:HB2	1.99	0.43
3:E:52(A):PRO:HA	3:E:71:VAL:HG21	2.01	0.43
1:A:103:LEU:HG	1:A:168:LEU:HD23	2.01	0.43
1:C:7:TYR:HB2	1:C:99:HIS:CE1	2.54	0.43
1:C:114:GLU:HG3	1:C:160:LEU:HD11	2.01	0.42
4:F:210:ASN:HB2	4:F:214:CYS:HA	2.01	0.42
1:C:5:LEU:HB2	1:C:168:LEU:HD13	2.02	0.42
2:D:92:LYS:HE2	2:D:92:LYS:HB3	1.85	0.42
3:E:119:PRO:HB3	3:E:145:TYR:HB3	2.02	0.41
2:B:97:ASP:HB3	2:B:100:MET:HG3	2.02	0.41
4:H:169:LYS:HA	4:H:169:LYS:HD3	1.84	0.41
1:C:6:LYS:HE2	1:C:113:TYR:OH	2.20	0.41
1:C:38:ASN:HA	1:C:43:PRO:CB	2.50	0.41

Continued on next page...

Continued from previous page...

Atom-1	Atom-2	Interatomic distance (Å)	Clash overlap (Å)
3:E:4:LEU:HB2	3:E:104:GLY:HA2	2.01	0.41
4:F:199:GLN:HG2	8:F:540:HOH:O	2.21	0.40
4:F:145:LYS:HB3	4:F:197:THR:HB	2.03	0.40
1:A:81:LEU:HD23	1:A:118:TYR:CG	2.56	0.40
2:B:26:CYS:HB2	2:B:40:LEU:HD21	2.04	0.40
4:H:39:LYS:HB2	4:H:42:LYS:HD2	2.04	0.40

There are no symmetry-related clashes.

5.3 Torsion angles [i](#)

5.3.1 Protein backbone [i](#)

In the following table, the Percentiles column shows the percent Ramachandran outliers of the chain as a percentile score with respect to all X-ray entries followed by that with respect to entries of similar resolution.

The Analysed column shows the number of residues for which the backbone conformation was analysed, and the total number of residues.

Mol	Chain	Analysed	Favoured	Allowed	Outliers	Percentiles	
1	A	274/276 (99%)	272 (99%)	2 (1%)	0	100	100
1	C	255/276 (92%)	250 (98%)	5 (2%)	0	100	100
2	B	98/100 (98%)	97 (99%)	1 (1%)	0	100	100
2	D	96/100 (96%)	95 (99%)	1 (1%)	0	100	100
3	E	214/244 (88%)	208 (97%)	6 (3%)	0	100	100
3	G	223/244 (91%)	219 (98%)	4 (2%)	0	100	100
4	F	212/233 (91%)	208 (98%)	4 (2%)	0	100	100
4	H	212/233 (91%)	210 (99%)	2 (1%)	0	100	100
5	P	7/9 (78%)	6 (86%)	1 (14%)	0	100	100
5	Q	7/9 (78%)	6 (86%)	1 (14%)	0	100	100
All	All	1598/1724 (93%)	1571 (98%)	27 (2%)	0	100	100

There are no Ramachandran outliers to report.

5.3.2 Protein sidechains [i](#)

In the following table, the Percentiles column shows the percent sidechain outliers of the chain as a percentile score with respect to all X-ray entries followed by that with respect to entries of similar resolution.

The Analysed column shows the number of residues for which the sidechain conformation was analysed, and the total number of residues.

Mol	Chain	Analysed	Rotameric	Outliers	Percentiles	
1	A	237/237 (100%)	235 (99%)	2 (1%)	81	78
1	C	224/237 (94%)	224 (100%)	0	100	100
2	B	95/95 (100%)	94 (99%)	1 (1%)	73	68
2	D	93/95 (98%)	93 (100%)	0	100	100
3	E	187/208 (90%)	186 (100%)	1 (0%)	88	87
3	G	193/208 (93%)	192 (100%)	1 (0%)	88	87
4	F	190/205 (93%)	190 (100%)	0	100	100
4	H	190/205 (93%)	190 (100%)	0	100	100
5	P	8/8 (100%)	8 (100%)	0	100	100
5	Q	8/8 (100%)	8 (100%)	0	100	100
All	All	1425/1506 (95%)	1420 (100%)	5 (0%)	91	89

All (5) residues with a non-rotameric sidechain are listed below:

Mol	Chain	Res	Type
1	A	35	ARG
1	A	39	ASP
2	B	71	PHE
3	G	35	ASP
3	E	35	ASP

Sometimes sidechains can be flipped to improve hydrogen bonding and reduce clashes. There are no such sidechains identified.

5.3.3 RNA [i](#)

There are no RNA molecules in this entry.

5.4 Non-standard residues in protein, DNA, RNA chains [i](#)

There are no non-standard protein/DNA/RNA residues in this entry.

5.5 Carbohydrates [i](#)

There are no monosaccharides in this entry.

5.6 Ligand geometry [i](#)

Of 11 ligands modelled in this entry, 1 is monoatomic - leaving 10 for Mogul analysis.

In the following table, the Counts columns list the number of bonds (or angles) for which Mogul statistics could be retrieved, the number of bonds (or angles) that are observed in the model and the number of bonds (or angles) that are defined in the Chemical Component Dictionary. The Link column lists molecule types, if any, to which the group is linked. The Z score for a bond length (or angle) is the number of standard deviations the observed value is removed from the expected value. A bond length (or angle) with $|Z| > 2$ is considered an outlier worth inspection. RMSZ is the root-mean-square of all Z scores of the bond lengths (or angles).

Mol	Type	Chain	Res	Link	Bond lengths			Bond angles		
					Counts	RMSZ	$\# Z > 2$	Counts	RMSZ	$\# Z > 2$
6	GOL	H	301	-	5,5,5	0.99	0	5,5,5	0.94	0
6	GOL	H	302	-	5,5,5	0.83	0	5,5,5	0.96	0
6	GOL	A	403	-	5,5,5	0.88	0	5,5,5	0.97	0
6	GOL	G	301	-	5,5,5	0.90	0	5,5,5	0.94	0
6	GOL	A	401	-	5,5,5	0.86	0	5,5,5	0.97	0
6	GOL	C	301	-	5,5,5	0.94	0	5,5,5	0.95	0
6	GOL	B	201	-	5,5,5	0.90	0	5,5,5	0.96	0
6	GOL	F	301	-	5,5,5	0.76	0	5,5,5	1.04	0
6	GOL	A	402	-	5,5,5	0.97	0	5,5,5	0.75	0
6	GOL	B	202	-	5,5,5	0.97	0	5,5,5	0.97	0

In the following table, the Chirals column lists the number of chiral outliers, the number of chiral centers analysed, the number of these observed in the model and the number defined in the Chemical Component Dictionary. Similar counts are reported in the Torsion and Rings columns. '-' means no outliers of that kind were identified.

Mol	Type	Chain	Res	Link	Chirals	Torsions	Rings
6	GOL	H	301	-	-	2/4/4/4	-
6	GOL	H	302	-	-	2/4/4/4	-
6	GOL	A	403	-	-	0/4/4/4	-
6	GOL	G	301	-	-	2/4/4/4	-

Continued on next page...

Continued from previous page...

Mol	Type	Chain	Res	Link	Chirals	Torsions	Rings
6	GOL	A	401	-	-	0/4/4/4	-
6	GOL	C	301	-	-	0/4/4/4	-
6	GOL	B	201	-	-	0/4/4/4	-
6	GOL	F	301	-	-	2/4/4/4	-
6	GOL	A	402	-	-	3/4/4/4	-
6	GOL	B	202	-	-	2/4/4/4	-

There are no bond length outliers.

There are no bond angle outliers.

There are no chirality outliers.

All (13) torsion outliers are listed below:

Mol	Chain	Res	Type	Atoms
6	H	301	GOL	C1-C2-C3-O3
6	F	301	GOL	C1-C2-C3-O3
6	A	402	GOL	O1-C1-C2-C3
6	B	202	GOL	O1-C1-C2-C3
6	G	301	GOL	C1-C2-C3-O3
6	H	302	GOL	C1-C2-C3-O3
6	F	301	GOL	O2-C2-C3-O3
6	H	301	GOL	O2-C2-C3-O3
6	A	402	GOL	O2-C2-C3-O3
6	B	202	GOL	O1-C1-C2-O2
6	A	402	GOL	O1-C1-C2-O2
6	G	301	GOL	O2-C2-C3-O3
6	H	302	GOL	O2-C2-C3-O3

There are no ring outliers.

1 monomer is involved in 1 short contact:

Mol	Chain	Res	Type	Clashes	Symm-Clashes
6	A	403	GOL	1	0

5.7 Other polymers [i](#)

There are no such residues in this entry.

5.8 Polymer linkage issues

There are no chain breaks in this entry.

6 Fit of model and data

6.1 Protein, DNA and RNA chains

In the following table, the column labelled ‘#RSRZ > 2’ contains the number (and percentage) of RSRZ outliers, followed by percent RSRZ outliers for the chain as percentile scores relative to all X-ray entries and entries of similar resolution. The OWAB column contains the minimum, median, 95th percentile and maximum values of the occupancy-weighted average B-factor per residue. The column labelled ‘Q < 0.9’ lists the number of (and percentage) of residues with an average occupancy less than 0.9.

Mol	Chain	Analysed	<RSRZ>	#RSRZ>2	OWAB(Å ²)	Q<0.9
1	A	276/276 (100%)	0.08	8 (2%) 51 46	25, 38, 65, 90	0
1	C	261/276 (94%)	1.05	67 (25%) 0 0	42, 60, 116, 137	0
2	B	100/100 (100%)	-0.12	3 (3%) 50 44	30, 39, 62, 89	0
2	D	98/100 (98%)	2.50	51 (52%) 0 0	48, 94, 132, 139	0
3	E	218/244 (89%)	0.12	10 (4%) 32 26	39, 53, 75, 91	0
3	G	225/244 (92%)	-0.13	1 (0%) 92 90	25, 39, 60, 82	0
4	F	214/233 (91%)	0.09	2 (0%) 84 82	29, 43, 62, 83	0
4	H	214/233 (91%)	0.18	1 (0%) 91 89	25, 36, 56, 87	0
5	P	9/9 (100%)	0.18	0 100 100	28, 34, 38, 54	0
5	Q	9/9 (100%)	-0.00	0 100 100	44, 48, 53, 61	0
All	All	1624/1724 (94%)	0.36	143 (8%) 10 7	25, 45, 100, 139	0

All (143) RSRZ outliers are listed below:

Mol	Chain	Res	Type	RSRZ
1	C	248	VAL	9.5
2	D	80	ALA	9.2
1	C	249	VAL	8.6
2	D	74	THR	8.5
2	D	24	LEU	8.1
1	C	42	SER	8.0
1	C	250	PRO	7.6
2	D	79	TYR	7.6
2	D	50	VAL	7.5
1	C	267	PRO	7.4
2	D	23	PHE	6.8
4	H	214	CYS	6.4
1	C	274	TRP	6.1

Continued on next page...

Continued from previous page...

Mol	Chain	Res	Type	RSRZ
1	C	201	LEU	6.1
1	C	252	GLY	6.0
1	C	217	TRP	6.0
2	D	96	TRP	5.9
2	D	72	THR	5.8
2	D	73	PRO	5.8
2	D	15	PRO	5.8
2	D	94	VAL	5.7
2	D	40	LEU	5.7
2	D	81	CYS	5.5
2	D	1	MET	5.3
1	C	257	TYR	5.2
1	C	271	THR	4.9
2	D	45	GLU	4.9
2	D	47	ILE	4.9
2	D	75	GLU	4.8
1	C	41	ALA	4.8
2	D	71	PHE	4.8
2	D	70	GLU	4.7
2	D	16	ALA	4.6
2	D	49	LYS	4.4
1	C	273	ARG	4.3
1	C	255	GLN	4.2
1	C	260	HIS	4.2
1	A	42	SER	4.2
1	C	246	ALA	4.2
2	D	22	ASN	4.1
2	D	78	GLU	4.1
2	D	68	TYR	4.0
2	D	11	TYR	4.0
1	C	179	LEU	4.0
1	C	182	LEU	4.0
1	C	218	GLN	4.0
2	D	93	ILE	3.9
1	A	222	GLU	3.9
1	C	244	TRP	3.9
2	D	26	CYS	3.9
2	B	1	MET	3.8
1	C	265	GLY	3.8
1	C	213	ILE	3.7
2	B	2	ILE	3.7
1	C	253	GLU	3.7

Continued on next page...

Continued from previous page...

Mol	Chain	Res	Type	RSRZ
1	C	228	THR	3.7
2	D	10	VAL	3.7
2	D	82	ARG	3.6
2	D	19	GLY	3.5
2	D	95	LYS	3.5
3	E	190	GLY	3.5
2	D	41	LEU	3.4
2	D	97	ASP	3.4
2	D	46	ARG	3.4
2	D	69	THR	3.3
1	C	204	TRP	3.3
2	D	98	ARG	3.3
1	C	247	VAL	3.3
1	C	31	THR	3.3
1	C	180	LEU	3.2
1	C	40	ALA	3.2
2	D	77	ASP	3.2
3	E	158	ALA	3.1
1	C	206	LEU	3.1
2	D	21	SER	3.1
1	C	187	THR	3.1
2	D	76	LYS	3.1
2	D	51	GLU	3.1
2	D	20	LYS	3.1
2	D	67	TYR	3.1
1	A	225	THR	3.0
2	D	83	VAL	3.0
2	D	8	ILE	3.0
1	C	210	PRO	3.0
2	D	42	LYS	2.9
2	D	17	GLU	2.9
2	D	25	ASN	2.9
4	F	41	GLY	2.8
3	E	201	LYS	2.8
1	C	203	CYS	2.8
1	C	209	TYR	2.8
3	E	204	ASN	2.8
1	A	41	ALA	2.7
1	C	181	HIS	2.7
3	E	156	SER	2.7
3	E	128	SER	2.7
2	D	27	TYR	2.6

Continued on next page...

Continued from previous page...

Mol	Chain	Res	Type	RSRZ
1	C	15	PRO	2.6
1	C	272	LEU	2.6
1	C	104	GLY	2.6
1	C	105	PRO	2.6
1	A	17	ARG	2.6
1	C	2	SER	2.6
1	C	184	PRO	2.6
1	C	256	ARG	2.6
3	E	42	GLY	2.6
1	C	237	GLY	2.6
3	G	132	SER	2.5
1	C	268	GLU	2.5
1	C	227	ASP	2.5
1	C	235	PRO	2.5
1	C	205	ALA	2.5
1	C	245	ALA	2.5
1	C	207	GLY	2.5
1	C	28	VAL	2.4
1	C	240	THR	2.4
1	C	241	PHE	2.4
1	C	216	THR	2.4
1	A	224	HIS	2.4
1	C	214	THR	2.3
4	F	214	CYS	2.3
2	D	14	HIS	2.3
1	C	190	THR	2.3
1	C	229	GLU	2.3
1	C	215	LEU	2.3
1	C	1	GLY	2.3
3	E	193	THR	2.2
1	C	234	ARG	2.2
2	D	39	ASP	2.2
1	C	186	LYS	2.2
1	C	189	VAL	2.2
1	A	220	ASP	2.2
1	C	266	LEU	2.2
2	B	90	GLN	2.2
3	E	202	PRO	2.1
1	C	103	LEU	2.1
2	D	9	GLN	2.1
1	A	227	ASP	2.1
1	C	270	VAL	2.1

Continued on next page...

Continued from previous page...

Mol	Chain	Res	Type	RSRZ
1	C	177	GLU	2.0
1	C	212	GLU	2.0
1	C	230	LEU	2.0
3	E	191	THR	2.0

6.2 Non-standard residues in protein, DNA, RNA chains [i](#)

There are no non-standard protein/DNA/RNA residues in this entry.

6.3 Carbohydrates [i](#)

There are no monosaccharides in this entry.

6.4 Ligands [i](#)

In the following table, the Atoms column lists the number of modelled atoms in the group and the number defined in the chemical component dictionary. The B-factors column lists the minimum, median, 95th percentile and maximum values of B factors of atoms in the group. The column labelled 'Q< 0.9' lists the number of atoms with occupancy less than 0.9.

Mol	Type	Chain	Res	Atoms	RSCC	RSR	B-factors(Å ²)	Q<0.9
6	GOL	A	403	6/6	0.69	0.13	62,66,68,70	0
6	GOL	B	202	6/6	0.73	0.20	48,57,64,72	0
6	GOL	C	301	6/6	0.78	0.32	68,82,86,87	0
6	GOL	H	301	6/6	0.83	0.14	41,58,65,67	0
6	GOL	H	302	6/6	0.85	0.21	45,63,65,67	0
6	GOL	G	301	6/6	0.89	0.10	51,58,63,63	0
6	GOL	F	301	6/6	0.89	0.16	41,54,66,67	0
6	GOL	A	401	6/6	0.91	0.11	44,49,53,55	0
6	GOL	B	201	6/6	0.92	0.22	38,51,57,62	0
6	GOL	A	402	6/6	0.93	0.10	42,47,52,59	0
7	CA	G	302	1/1	0.97	0.09	63,63,63,63	0

6.5 Other polymers [i](#)

There are no such residues in this entry.