



## wwPDB EM Validation Summary Report

Nov 20, 2022 – 11:11 pm GMT

PDB ID : 4CTF  
EMDB ID : EMD-2389  
Title : The limits of structural plasticity in a picornavirus capsid revealed by a massively expanded equine rhinitis A virus particle  
Authors : Bakker, S.E.; Groppelli, E.; Pearson, A.R.; Stockley, P.G.; Rowlands, D.J.; Ranson, N.A.  
Deposited on : 2014-03-13  
Resolution : 17.00 Å (reported)  
Based on initial model : 2WFF

This is a wwPDB EM Validation Summary Report for a publicly released PDB entry.

We welcome your comments at [validation@mail.wwpdb.org](mailto:validation@mail.wwpdb.org)

A user guide is available at

<https://www.wwpdb.org/validation/2017/EMValidationReportHelp>

with specific help available everywhere you see the  symbol.

The types of validation reports are described at

<http://www.wwpdb.org/validation/2017/FAQs#types>.

---

The following versions of software and data (see [references](#) ) were used in the production of this report:

EMDB validation analysis : 0.0.1.dev43  
MolProbity : 4.02b-467  
Percentile statistics : 20191225.v01 (using entries in the PDB archive December 25th 2019)  
MapQ : 1.9.9  
Ideal geometry (proteins) : Engh & Huber (2001)  
Ideal geometry (DNA, RNA) : Parkinson et al. (1996)  
Validation Pipeline (wwPDB-VP) : 2.31.2

# 1 Overall quality at a glance

The following experimental techniques were used to determine the structure:

*ELECTRON MICROSCOPY*

The reported resolution of this entry is 17.00 Å.

Percentile scores (ranging between 0-100) for global validation metrics of the entry are shown in the following graphic. The table shows the number of entries on which the scores are based.

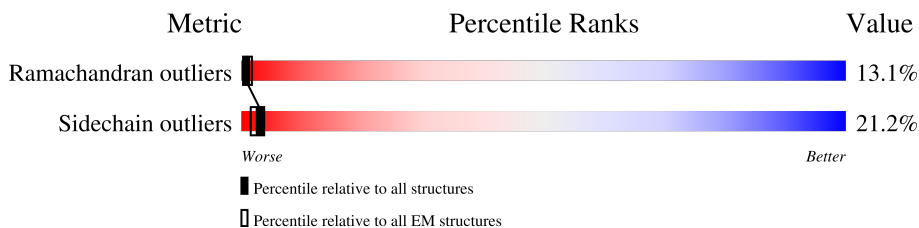

Metric	Whole archive (#Entries)	EM structures (#Entries)
Ramachandran outliers	154571	4023
Sidechain outliers	154315	3826

The table below summarises the geometric issues observed across the polymeric chains and their fit to the map. The red, orange, yellow and green segments of the bar indicate the fraction of residues that contain outliers for  $\geq 3$ , 2, 1 and 0 types of geometric quality criteria respectively. A grey segment represents the fraction of residues that are not modelled. The numeric value for each fraction is indicated below the corresponding segment, with a dot representing fractions  $\leq 5\%$ . The upper red bar (where present) indicates the fraction of residues that have poor fit to the EM map (all-atom inclusion  $< 40\%$ ). The numeric value is given above the bar.

Mol	Chain	Length	Quality of chain
1	A0	246	13% 72% 24% ..
1	A1	246	10% 72% 25% ..
1	A2	246	11% 72% 24% ..
1	A3	246	11% 72% 24% ..
1	A4	246	11% 72% 24% ..
1	A5	246	13% 72% 25% ..
1	A6	246	12% 72% 25% ..
1	A7	246	11% 72% 25% ..
1	A8	246	11% 72% 24% ..











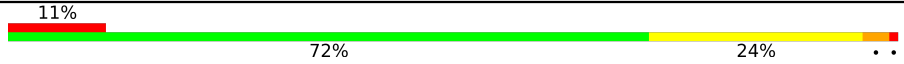

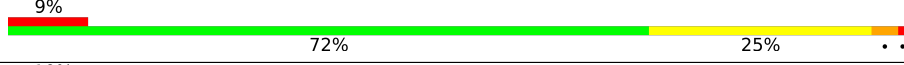

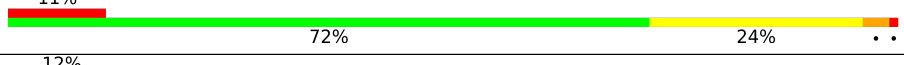
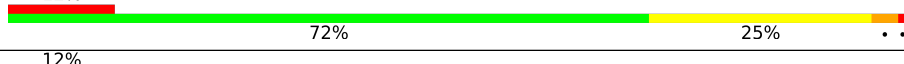
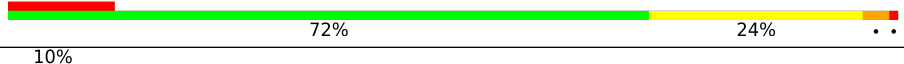
*Continued on next page...*

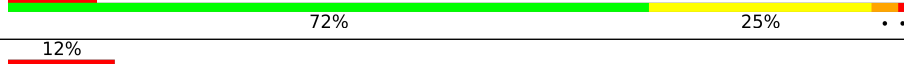
Continued from previous page...

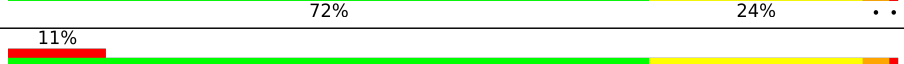
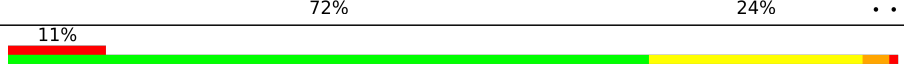
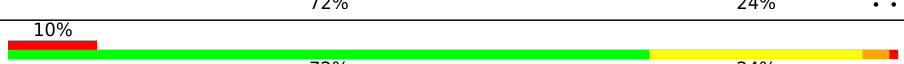
Mol	Chain	Length	Quality of chain	
1	A9	246	13%	72% 24% ..
1	AA	246	13%	72% 24% ..
1	AB	246	13%	72% 24% ..
1	AC	246	12%	72% 24% ..
1	AD	246	12%	72% 24% ..
1	AE	246	13%	72% 25% ..
1	AF	246	13%	72% 24% ..
1	AG	246	11%	72% 24% ..
1	AH	246	12%	72% 25% ..
1	AI	246	11%	72% 25% ..
1	AJ	246	12%	72% 24% ..
1	AK	246	10%	72% 24% ..
1	AL	246	10%	72% 24% ..
1	AM	246	11%	72% 25% ..
1	AN	246	13%	72% 24% ..
1	AO	246	12%	72% 25% ..
1	AP	246	10%	72% 24% ..
1	AQ	246	10%	72% 24% ..
1	AR	246	11%	72% 24% ..
1	AS	246	12%	72% 24% ..
1	AT	246	11%	72% 25% ..
1	AU	246	11%	72% 24% ..
1	AV	246	12%	72% 24% ..
1	AW	246	11%	72% 24% ..
1	AX	246	11%	72% 24% ..

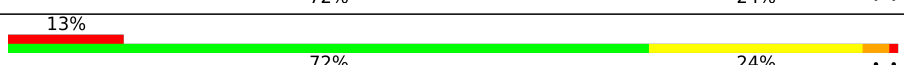
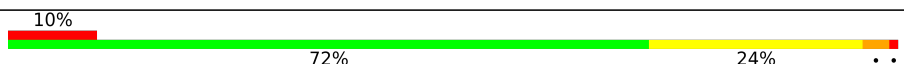
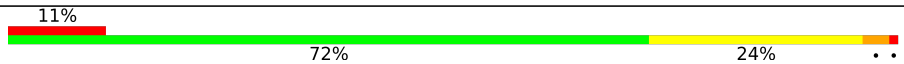
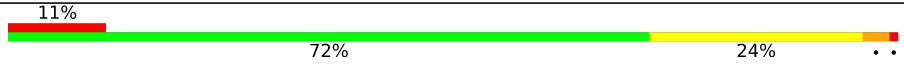
Continued on next page...

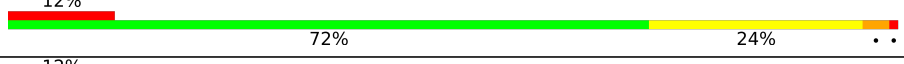
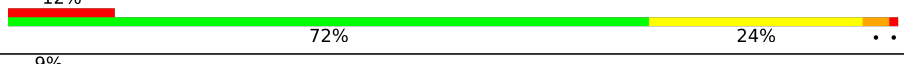
Continued from previous page...

Mol	Chain	Length	Quality of chain
1	AY	246	
1	AZ	246	
1	Aa	246	
1	Ab	246	
1	Ac	246	
1	Ad	246	
1	Ae	246	
1	Af	246	
1	Ag	246	
1	Ah	246	
1	Ai	246	
1	Aj	246	
1	Ak	246	
1	Al	246	
1	Am	246	
1	An	246	
1	Ao	246	
1	BA	246	
1	BB	246	
1	BC	246	
1	BD	246	
1	BE	246	
1	BF	246	
1	BG	246	
1	BH	246	

Continued on next page...

Continued from previous page...

Mol	Chain	Length	Quality of chain
1	BI	246	
2	C0	230	
2	C1	230	
2	C2	230	
2	C3	230	
2	C4	230	
2	C5	230	
2	C6	230	
2	C7	230	
2	C8	230	
2	C9	230	
2	CA	230	
2	CB	230	
2	CC	230	
2	CD	230	
2	CE	230	
2	CF	230	
2	CG	230	
2	CH	230	
2	CI	230	
2	CJ	230	
2	CK	230	
2	CL	230	
2	CM	230	
2	CN	230	

Continued on next page...

Continued from previous page...

Mol	Chain	Length	Quality of chain
2	CO	230	7% 60% 23% 14%
2	CP	230	7% 60% 23% 14%
2	CQ	230	8% 60% 23% 14%
2	CR	230	8% 60% 23% 14%
2	CS	230	7% 60% 23% 14%
2	CT	230	7% 60% 23% 14%
2	CU	230	9% 60% 23% 14%
2	CV	230	13% 60% 23% 14%
2	CW	230	11% 60% 23% 14%
2	CX	230	8% 60% 23% 14%
2	CY	230	7% 60% 23% 14%
2	CZ	230	7% 60% 23% 14%
2	Ca	230	7% 60% 23% 14%
2	Cb	230	7% 60% 23% 14%
2	Cc	230	8% 60% 23% 14%
2	Cd	230	7% 60% 23% 14%
2	Ce	230	10% 60% 23% 14%
2	Cf	230	9% 60% 23% 14%
2	Cg	230	7% 60% 23% 14%
2	Ch	230	7% 60% 23% 14%
2	Ci	230	9% 60% 23% 14%
2	Cj	230	7% 60% 23% 14%
2	Ck	230	8% 60% 23% 14%
2	Cl	230	10% 60% 23% 14%
2	Cm	230	11% 60% 23% 14%

Continued on next page...

Continued from previous page...

Mol	Chain	Length	Quality of chain			
2	Cn	230	8%	60%	23%	14%
2	Co	230	7%	60%	23%	14%
2	Cp	230	7%	60%	23%	14%
2	Cq	230	9%	60%	23%	14%
2	Cr	230	8%	60%	23%	14%
2	Cs	230	7%	60%	23%	14%
2	Ct	230	9%	60%	23%	14%
2	Cu	230	8%	60%	23%	14%
2	Cv	230	7%	60%	23%	14%
2	Cw	230	7%	60%	23%	14%
2	Cx	230	8%	60%	23%	14%
3	D0	226	9%	69%	29%	•
3	D1	226	9%	70%	28%	•
3	D2	226	8%	69%	29%	•
3	D3	226	9%	69%	29%	•
3	D4	226	10%	69%	29%	•
3	D5	226	14%	69%	29%	•
3	D6	226	14%	69%	29%	•
3	D7	226	13%	69%	29%	•
3	D8	226	10%	69%	29%	•
3	D9	226	9%	70%	28%	•
3	DA	226	15%	69%	29%	•
3	DB	226	12%	69%	29%	•
3	DC	226	12%	69%	29%	•
3	DD	226	14%	70%	28%	•

Continued on next page...

Continued from previous page...

Mol	Chain	Length	Quality of chain		
3	DE	226	15%	69%	29%
3	DF	226	15%	69%	29%
3	DG	226	11%	69%	29%
3	DH	226	12%	69%	29%
3	DI	226	12%	69%	29%
3	DJ	226	15%	69%	29%
3	DK	226	11%	69%	29%
3	DL	226	8%	69%	29%
3	DM	226	8%	69%	29%
3	DN	226	9%	69%	29%
3	DO	226	10%	69%	29%
3	DP	226	10%	69%	29%
3	DQ	226	10%	69%	29%
3	DR	226	9%	70%	28%
3	DS	226	9%	69%	29%
3	DT	226	10%	69%	29%
3	DU	226	10%	69%	29%
3	DV	226	14%	69%	29%
3	DW	226	15%	69%	29%
3	DX	226	10%	69%	29%
3	DY	226	8%	69%	29%
3	DZ	226	8%	69%	29%
3	Da	226	9%	69%	29%
3	Db	226	9%	69%	29%
3	Dc	226	9%	69%	29%

Continued on next page...



Continued from previous page...

Mol	Chain	Length	Quality of chain
3	Dd	226	11% 69% 29%
3	De	226	12% 69% 29%
3	Df	226	12% 69% 29%
3	Dg	226	9% 69% 29%
3	Dh	226	9% 69% 29%
3	Di	226	10% 69% 29%
3	Dj	226	8% 70% 28%
3	Dk	226	9% 69% 29%
3	Dl	226	12% 69% 29%
3	Dm	226	11% 69% 29%
3	Dn	226	11% 69% 29%
3	Do	226	8% 69% 29%
3	Dp	226	10% 69% 29%
3	Dq	226	12% 70% 28%
3	Dr	226	10% 69% 29%
3	Ds	226	10% 69% 29%
3	EA	226	12% 69% 29%
3	EB	226	11% 69% 29%
3	EC	226	9% 69% 29%
3	ED	226	9% 69% 29%
3	EE	226	10% 69% 29%
4	F0	80	21% 19% 6% 72%
4	F1	80	22% 19% 6% 72%
4	F2	80	24% 19% 6% 72%
4	F3	80	22% 19% 6% 72%

Continued on next page...

Continued from previous page...

Mol	Chain	Length	Quality of chain
4	F4	80	
4	F5	80	
4	F6	80	
4	F7	80	
4	F8	80	
4	F9	80	
4	FA	80	
4	FB	80	
4	FC	80	
4	FD	80	
4	FE	80	
4	FF	80	
4	FG	80	
4	FH	80	
4	FI	80	
4	FJ	80	
4	FK	80	
4	FL	80	
4	FM	80	
4	FN	80	
4	FO	80	
4	FP	80	
4	FQ	80	
4	FR	80	
4	FS	80	

Continued on next page...

Continued from previous page...

Mol	Chain	Length	Quality of chain
4	FT	80	20% 19% 6% . 72%
4	FU	80	24% 19% 6% . 72%
4	FV	80	25% 19% 6% . 72%
4	FW	80	26% 19% 6% . 72%
4	FX	80	25% 19% 6% . 72%
4	FY	80	24% 19% 6% . 72%
4	FZ	80	22% 19% 6% . 72%
4	Fa	80	22% 19% 6% . 72%
4	Fb	80	22% 19% 6% . 72%
4	Fc	80	24% 19% 6% . 72%
4	Fd	80	22% 19% 6% . 72%
4	Fe	80	25% 19% 6% . 72%
4	Ff	80	24% 19% 6% . 72%
4	Fg	80	24% 19% 6% . 72%
4	Fh	80	22% 19% 6% . 72%
4	Fi	80	24% 19% 6% . 72%
4	Fj	80	24% 19% 6% . 72%
4	Fk	80	24% 19% 6% . 72%
4	Fl	80	24% 19% 6% . 72%
4	Fm	80	25% 19% 6% . 72%
4	Fn	80	24% 19% 6% . 72%
4	Fo	80	22% 19% 6% . 72%
4	Fp	80	22% 19% 6% . 72%
4	Fq	80	24% 19% 6% . 72%
4	Fr	80	24% 19% 6% . 72%

Continued on next page...

*Continued from previous page...*

Mol	Chain	Length	Quality of chain
4	Fs	80	<p>22% 19% 6% • 72%</p>
4	Ft	80	<p>24% 19% 6% • 72%</p>
4	Fu	80	<p>24% 19% 6% • 72%</p>
4	Fv	80	<p>24% 19% 6% • 72%</p>
4	Fw	80	<p>22% 19% 6% • 72%</p>
4	Fx	80	<p>24% 19% 6% • 72%</p>

## 2 Entry composition [i](#)

There are 4 unique types of molecules in this entry. The entry contains 321060 atoms, of which 0 are hydrogens and 0 are deuteriums.

In the tables below, the AltConf column contains the number of residues with at least one atom in alternate conformation and the Trace column contains the number of residues modelled with at most 2 atoms.

- Molecule 1 is a protein called VP1.

Mol	Chain	Residues	Atoms					AltConf	Trace
			Total	C	N	O	S		
1	A0	246	1929	1240	329	352	8	0	0
1	A1	246	1929	1240	329	352	8	0	0
1	A2	246	1929	1240	329	352	8	0	0
1	A3	246	1929	1240	329	352	8	0	0
1	A4	246	1929	1240	329	352	8	0	0
1	A5	246	1929	1240	329	352	8	0	0
1	A6	246	1929	1240	329	352	8	0	0
1	A7	246	1929	1240	329	352	8	0	0
1	A8	246	1929	1240	329	352	8	0	0
1	A9	246	1929	1240	329	352	8	0	0
1	AA	246	1929	1240	329	352	8	0	0
1	AB	246	1929	1240	329	352	8	0	0
1	AC	246	1929	1240	329	352	8	0	0
1	AD	246	1929	1240	329	352	8	0	0
1	AE	246	1929	1240	329	352	8	0	0
1	AF	246	1929	1240	329	352	8	0	0
1	AG	246	1929	1240	329	352	8	0	0

*Continued on next page...*

*Continued from previous page...*

Mol	Chain	Residues	Atoms					AltConf	Trace
1	AH	246	Total 1929	C 1240	N 329	O 352	S 8	0	0
1	AI	246	Total 1929	C 1240	N 329	O 352	S 8	0	0
1	AJ	246	Total 1929	C 1240	N 329	O 352	S 8	0	0
1	AK	246	Total 1929	C 1240	N 329	O 352	S 8	0	0
1	AL	246	Total 1929	C 1240	N 329	O 352	S 8	0	0
1	AM	246	Total 1929	C 1240	N 329	O 352	S 8	0	0
1	AN	246	Total 1929	C 1240	N 329	O 352	S 8	0	0
1	AO	246	Total 1929	C 1240	N 329	O 352	S 8	0	0
1	AP	246	Total 1929	C 1240	N 329	O 352	S 8	0	0
1	AQ	246	Total 1929	C 1240	N 329	O 352	S 8	0	0
1	AR	246	Total 1929	C 1240	N 329	O 352	S 8	0	0
1	AS	246	Total 1929	C 1240	N 329	O 352	S 8	0	0
1	AT	246	Total 1929	C 1240	N 329	O 352	S 8	0	0
1	AU	246	Total 1929	C 1240	N 329	O 352	S 8	0	0
1	AV	246	Total 1929	C 1240	N 329	O 352	S 8	0	0
1	AW	246	Total 1929	C 1240	N 329	O 352	S 8	0	0
1	AX	246	Total 1929	C 1240	N 329	O 352	S 8	0	0
1	AY	246	Total 1929	C 1240	N 329	O 352	S 8	0	0
1	AZ	246	Total 1929	C 1240	N 329	O 352	S 8	0	0
1	Aa	246	Total 1929	C 1240	N 329	O 352	S 8	0	0
1	Ab	246	Total 1929	C 1240	N 329	O 352	S 8	0	0

*Continued on next page...*

*Continued from previous page...*

Mol	Chain	Residues	Atoms					AltConf	Trace
1	Ac	246	Total 1929	C 1240	N 329	O 352	S 8	0	0
1	Ad	246	Total 1929	C 1240	N 329	O 352	S 8	0	0
1	Ae	246	Total 1929	C 1240	N 329	O 352	S 8	0	0
1	Af	246	Total 1929	C 1240	N 329	O 352	S 8	0	0
1	Ag	246	Total 1929	C 1240	N 329	O 352	S 8	0	0
1	Ah	246	Total 1929	C 1240	N 329	O 352	S 8	0	0
1	Ai	246	Total 1929	C 1240	N 329	O 352	S 8	0	0
1	Aj	246	Total 1929	C 1240	N 329	O 352	S 8	0	0
1	Ak	246	Total 1929	C 1240	N 329	O 352	S 8	0	0
1	Al	246	Total 1929	C 1240	N 329	O 352	S 8	0	0
1	Am	246	Total 1929	C 1240	N 329	O 352	S 8	0	0
1	An	246	Total 1929	C 1240	N 329	O 352	S 8	0	0
1	Ao	246	Total 1929	C 1240	N 329	O 352	S 8	0	0
1	BA	246	Total 1929	C 1240	N 329	O 352	S 8	0	0
1	BB	246	Total 1929	C 1240	N 329	O 352	S 8	0	0
1	BC	246	Total 1929	C 1240	N 329	O 352	S 8	0	0
1	BD	246	Total 1929	C 1240	N 329	O 352	S 8	0	0
1	BE	246	Total 1929	C 1240	N 329	O 352	S 8	0	0
1	BF	246	Total 1929	C 1240	N 329	O 352	S 8	0	0
1	BG	246	Total 1929	C 1240	N 329	O 352	S 8	0	0
1	BH	246	Total 1929	C 1240	N 329	O 352	S 8	0	0

*Continued on next page...*

*Continued from previous page...*

Mol	Chain	Residues	Atoms					AltConf	Trace
1	BI	246	Total	C	N	O	S	0	0
			1929	1240	329	352	8		

- Molecule 2 is a protein called EQUINE RHINITIS A VIRUS.

Mol	Chain	Residues	Atoms					AltConf	Trace
2	C0	198	Total	C	N	O	S	0	0
			1537	986	261	286	4		
2	C1	198	Total	C	N	O	S	0	0
			1537	986	261	286	4		
2	C2	198	Total	C	N	O	S	0	0
			1537	986	261	286	4		
2	C3	198	Total	C	N	O	S	0	0
			1537	986	261	286	4		
2	C4	198	Total	C	N	O	S	0	0
			1537	986	261	286	4		
2	C5	198	Total	C	N	O	S	0	0
			1537	986	261	286	4		
2	C6	198	Total	C	N	O	S	0	0
			1537	986	261	286	4		
2	C7	198	Total	C	N	O	S	0	0
			1537	986	261	286	4		
2	C8	198	Total	C	N	O	S	0	0
			1537	986	261	286	4		
2	C9	198	Total	C	N	O	S	0	0
			1537	986	261	286	4		
2	CA	198	Total	C	N	O	S	0	0
			1537	986	261	286	4		
2	CB	198	Total	C	N	O	S	0	0
			1537	986	261	286	4		
2	CC	198	Total	C	N	O	S	0	0
			1537	986	261	286	4		
2	CD	198	Total	C	N	O	S	0	0
			1537	986	261	286	4		
2	CE	198	Total	C	N	O	S	0	0
			1537	986	261	286	4		
2	CF	198	Total	C	N	O	S	0	0
			1537	986	261	286	4		
2	CG	198	Total	C	N	O	S	0	0
			1537	986	261	286	4		
2	CH	198	Total	C	N	O	S	0	0
			1537	986	261	286	4		

*Continued on next page...*



*Continued from previous page...*

Mol	Chain	Residues	Atoms					AltConf	Trace
			Total	C	N	O	S		
2	CI	198	1537	986	261	286	4	0	0
2	CJ	198	1537	986	261	286	4	0	0
2	CK	198	1537	986	261	286	4	0	0
2	CL	198	1537	986	261	286	4	0	0
2	CM	198	1537	986	261	286	4	0	0
2	CN	198	1537	986	261	286	4	0	0
2	CO	198	1537	986	261	286	4	0	0
2	CP	198	1537	986	261	286	4	0	0
2	CQ	198	1537	986	261	286	4	0	0
2	CR	198	1537	986	261	286	4	0	0
2	CS	198	1537	986	261	286	4	0	0
2	CT	198	1537	986	261	286	4	0	0
2	CU	198	1537	986	261	286	4	0	0
2	CV	198	1537	986	261	286	4	0	0
2	CW	198	1537	986	261	286	4	0	0
2	CX	198	1537	986	261	286	4	0	0
2	CY	198	1537	986	261	286	4	0	0
2	CZ	198	1537	986	261	286	4	0	0
2	Ca	198	1537	986	261	286	4	0	0
2	Cb	198	1537	986	261	286	4	0	0
2	Cc	198	1537	986	261	286	4	0	0

*Continued on next page...*

*Continued from previous page...*

Mol	Chain	Residues	Atoms					AltConf	Trace
			Total	C	N	O	S		
2	Cd	198	1537	986	261	286	4	0	0
2	Ce	198	1537	986	261	286	4	0	0
2	Cf	198	1537	986	261	286	4	0	0
2	Cg	198	1537	986	261	286	4	0	0
2	Ch	198	1537	986	261	286	4	0	0
2	Ci	198	1537	986	261	286	4	0	0
2	Cj	198	1537	986	261	286	4	0	0
2	Ck	198	1537	986	261	286	4	0	0
2	Cl	198	1537	986	261	286	4	0	0
2	Cm	198	1537	986	261	286	4	0	0
2	Cn	198	1537	986	261	286	4	0	0
2	Co	198	1537	986	261	286	4	0	0
2	Cp	198	1537	986	261	286	4	0	0
2	Cq	198	1537	986	261	286	4	0	0
2	Cr	198	1537	986	261	286	4	0	0
2	Cs	198	1537	986	261	286	4	0	0
2	Ct	198	1537	986	261	286	4	0	0
2	Cu	198	1537	986	261	286	4	0	0
2	Cv	198	1537	986	261	286	4	0	0
2	Cw	198	1537	986	261	286	4	0	0
2	Cx	198	1537	986	261	286	4	0	0

There are 60 discrepancies between the modelled and reference sequences:

Chain	Residue	Modelled	Actual	Comment	Reference
C0	85	SER	GLY	conflict	UNP Q91B42
C1	85	SER	GLY	conflict	UNP Q91B42
C2	85	SER	GLY	conflict	UNP Q91B42
C3	85	SER	GLY	conflict	UNP Q91B42
C4	85	SER	GLY	conflict	UNP Q91B42
C5	85	SER	GLY	conflict	UNP Q91B42
C6	85	SER	GLY	conflict	UNP Q91B42
C7	85	SER	GLY	conflict	UNP Q91B42
C8	85	SER	GLY	conflict	UNP Q91B42
C9	85	SER	GLY	conflict	UNP Q91B42
CA	85	SER	GLY	conflict	UNP Q91B42
CB	85	SER	GLY	conflict	UNP Q91B42
CC	85	SER	GLY	conflict	UNP Q91B42
CD	85	SER	GLY	conflict	UNP Q91B42
CE	85	SER	GLY	conflict	UNP Q91B42
CF	85	SER	GLY	conflict	UNP Q91B42
CG	85	SER	GLY	conflict	UNP Q91B42
CH	85	SER	GLY	conflict	UNP Q91B42
CI	85	SER	GLY	conflict	UNP Q91B42
CJ	85	SER	GLY	conflict	UNP Q91B42
CK	85	SER	GLY	conflict	UNP Q91B42
CL	85	SER	GLY	conflict	UNP Q91B42
CM	85	SER	GLY	conflict	UNP Q91B42
CN	85	SER	GLY	conflict	UNP Q91B42
CO	85	SER	GLY	conflict	UNP Q91B42
CP	85	SER	GLY	conflict	UNP Q91B42
CQ	85	SER	GLY	conflict	UNP Q91B42
CR	85	SER	GLY	conflict	UNP Q91B42
CS	85	SER	GLY	conflict	UNP Q91B42
CT	85	SER	GLY	conflict	UNP Q91B42
CU	85	SER	GLY	conflict	UNP Q91B42
CV	85	SER	GLY	conflict	UNP Q91B42
CW	85	SER	GLY	conflict	UNP Q91B42
CX	85	SER	GLY	conflict	UNP Q91B42
CY	85	SER	GLY	conflict	UNP Q91B42
CZ	85	SER	GLY	conflict	UNP Q91B42
Ca	85	SER	GLY	conflict	UNP Q91B42
Cb	85	SER	GLY	conflict	UNP Q91B42
Cc	85	SER	GLY	conflict	UNP Q91B42
Cd	85	SER	GLY	conflict	UNP Q91B42
Ce	85	SER	GLY	conflict	UNP Q91B42
Cf	85	SER	GLY	conflict	UNP Q91B42

*Continued on next page...*

*Continued from previous page...*

Chain	Residue	Modelled	Actual	Comment	Reference
Cg	85	SER	GLY	conflict	UNP Q91B42
Ch	85	SER	GLY	conflict	UNP Q91B42
Ci	85	SER	GLY	conflict	UNP Q91B42
Cj	85	SER	GLY	conflict	UNP Q91B42
Ck	85	SER	GLY	conflict	UNP Q91B42
Cl	85	SER	GLY	conflict	UNP Q91B42
Cm	85	SER	GLY	conflict	UNP Q91B42
Cn	85	SER	GLY	conflict	UNP Q91B42
Co	85	SER	GLY	conflict	UNP Q91B42
Cp	85	SER	GLY	conflict	UNP Q91B42
Cq	85	SER	GLY	conflict	UNP Q91B42
Cr	85	SER	GLY	conflict	UNP Q91B42
Cs	85	SER	GLY	conflict	UNP Q91B42
Ct	85	SER	GLY	conflict	UNP Q91B42
Cu	85	SER	GLY	conflict	UNP Q91B42
Cv	85	SER	GLY	conflict	UNP Q91B42
Cw	85	SER	GLY	conflict	UNP Q91B42
Cx	85	SER	GLY	conflict	UNP Q91B42

- Molecule 3 is a protein called P1.

Mol	Chain	Residues	Atoms					AltConf	Trace
3	D0	226	Total	C	N	O	S	0	0
			1719	1107	280	326	6		
3	D1	226	Total	C	N	O	S	0	0
			1719	1107	280	326	6		
3	D2	226	Total	C	N	O	S	0	0
			1719	1107	280	326	6		
3	D3	226	Total	C	N	O	S	0	0
			1719	1107	280	326	6		
3	D4	226	Total	C	N	O	S	0	0
			1719	1107	280	326	6		
3	D5	226	Total	C	N	O	S	0	0
			1719	1107	280	326	6		
3	D6	226	Total	C	N	O	S	0	0
			1719	1107	280	326	6		
3	D7	226	Total	C	N	O	S	0	0
			1719	1107	280	326	6		
3	D8	226	Total	C	N	O	S	0	0
			1719	1107	280	326	6		
3	D9	226	Total	C	N	O	S	0	0
			1719	1107	280	326	6		

*Continued on next page...*

*Continued from previous page...*

Mol	Chain	Residues	Atoms					AltConf	Trace
			Total	C	N	O	S		
3	DA	226	Total 1719	C 1107	N 280	O 326	S 6	0	0
3	DB	226	Total 1719	C 1107	N 280	O 326	S 6	0	0
3	DC	226	Total 1719	C 1107	N 280	O 326	S 6	0	0
3	DD	226	Total 1719	C 1107	N 280	O 326	S 6	0	0
3	DE	226	Total 1719	C 1107	N 280	O 326	S 6	0	0
3	DF	226	Total 1719	C 1107	N 280	O 326	S 6	0	0
3	DG	226	Total 1719	C 1107	N 280	O 326	S 6	0	0
3	DH	226	Total 1719	C 1107	N 280	O 326	S 6	0	0
3	DI	226	Total 1719	C 1107	N 280	O 326	S 6	0	0
3	DJ	226	Total 1719	C 1107	N 280	O 326	S 6	0	0
3	DK	226	Total 1719	C 1107	N 280	O 326	S 6	0	0
3	DL	226	Total 1719	C 1107	N 280	O 326	S 6	0	0
3	DM	226	Total 1719	C 1107	N 280	O 326	S 6	0	0
3	DN	226	Total 1719	C 1107	N 280	O 326	S 6	0	0
3	DO	226	Total 1719	C 1107	N 280	O 326	S 6	0	0
3	DP	226	Total 1719	C 1107	N 280	O 326	S 6	0	0
3	DQ	226	Total 1719	C 1107	N 280	O 326	S 6	0	0
3	DR	226	Total 1719	C 1107	N 280	O 326	S 6	0	0
3	DS	226	Total 1719	C 1107	N 280	O 326	S 6	0	0
3	DT	226	Total 1719	C 1107	N 280	O 326	S 6	0	0
3	DU	226	Total 1719	C 1107	N 280	O 326	S 6	0	0

*Continued on next page...*

*Continued from previous page...*

Mol	Chain	Residues	Atoms					AltConf	Trace
			Total	C	N	O	S		
3	DV	226	Total 1719	C 1107	N 280	O 326	S 6	0	0
3	DW	226	Total 1719	C 1107	N 280	O 326	S 6	0	0
3	DX	226	Total 1719	C 1107	N 280	O 326	S 6	0	0
3	DY	226	Total 1719	C 1107	N 280	O 326	S 6	0	0
3	DZ	226	Total 1719	C 1107	N 280	O 326	S 6	0	0
3	Da	226	Total 1719	C 1107	N 280	O 326	S 6	0	0
3	Db	226	Total 1719	C 1107	N 280	O 326	S 6	0	0
3	Dc	226	Total 1719	C 1107	N 280	O 326	S 6	0	0
3	Dd	226	Total 1719	C 1107	N 280	O 326	S 6	0	0
3	De	226	Total 1719	C 1107	N 280	O 326	S 6	0	0
3	Df	226	Total 1719	C 1107	N 280	O 326	S 6	0	0
3	Dg	226	Total 1719	C 1107	N 280	O 326	S 6	0	0
3	Dh	226	Total 1719	C 1107	N 280	O 326	S 6	0	0
3	Di	226	Total 1719	C 1107	N 280	O 326	S 6	0	0
3	Dj	226	Total 1719	C 1107	N 280	O 326	S 6	0	0
3	Dk	226	Total 1719	C 1107	N 280	O 326	S 6	0	0
3	Dl	226	Total 1719	C 1107	N 280	O 326	S 6	0	0
3	Dm	226	Total 1719	C 1107	N 280	O 326	S 6	0	0
3	Dn	226	Total 1719	C 1107	N 280	O 326	S 6	0	0
3	Do	226	Total 1719	C 1107	N 280	O 326	S 6	0	0
3	Dp	226	Total 1719	C 1107	N 280	O 326	S 6	0	0

*Continued on next page...*

*Continued from previous page...*

Mol	Chain	Residues	Atoms					AltConf	Trace
3	Dq	226	Total	C	N	O	S	0	0
			1719	1107	280	326	6		
3	Dr	226	Total	C	N	O	S	0	0
			1719	1107	280	326	6		
3	Ds	226	Total	C	N	O	S	0	0
			1719	1107	280	326	6		
3	EA	226	Total	C	N	O	S	0	0
			1719	1107	280	326	6		
3	EB	226	Total	C	N	O	S	0	0
			1719	1107	280	326	6		
3	EC	226	Total	C	N	O	S	0	0
			1719	1107	280	326	6		
3	ED	226	Total	C	N	O	S	0	0
			1719	1107	280	326	6		
3	EE	226	Total	C	N	O	S	0	0
			1719	1107	280	326	6		

- Molecule 4 is a protein called P1.

Mol	Chain	Residues	Atoms					AltConf	Trace
4	F0	22	Total	C	N	O	S	0	1
			166	101	29	35	1		
4	F1	22	Total	C	N	O	S	0	1
			166	101	29	35	1		
4	F2	22	Total	C	N	O	S	0	1
			166	101	29	35	1		
4	F3	22	Total	C	N	O	S	0	1
			166	101	29	35	1		
4	F4	22	Total	C	N	O	S	0	1
			166	101	29	35	1		
4	F5	22	Total	C	N	O	S	0	1
			166	101	29	35	1		
4	F6	22	Total	C	N	O	S	0	1
			166	101	29	35	1		
4	F7	22	Total	C	N	O	S	0	1
			166	101	29	35	1		
4	F8	22	Total	C	N	O	S	0	1
			166	101	29	35	1		
4	F9	22	Total	C	N	O	S	0	1
			166	101	29	35	1		
4	FA	22	Total	C	N	O	S	0	1
			166	101	29	35	1		

*Continued on next page...*

*Continued from previous page...*

Mol	Chain	Residues	Atoms					AltConf	Trace
			Total	C	N	O	S		
4	FB	22	Total 166	C 101	N 29	O 35	S 1	0	1
4	FC	22	Total 166	C 101	N 29	O 35	S 1	0	1
4	FD	22	Total 166	C 101	N 29	O 35	S 1	0	1
4	FE	22	Total 166	C 101	N 29	O 35	S 1	0	1
4	FF	22	Total 166	C 101	N 29	O 35	S 1	0	1
4	FG	22	Total 166	C 101	N 29	O 35	S 1	0	1
4	FH	22	Total 166	C 101	N 29	O 35	S 1	0	1
4	FI	22	Total 166	C 101	N 29	O 35	S 1	0	1
4	FJ	22	Total 166	C 101	N 29	O 35	S 1	0	1
4	FK	22	Total 166	C 101	N 29	O 35	S 1	0	1
4	FL	22	Total 166	C 101	N 29	O 35	S 1	0	1
4	FM	22	Total 166	C 101	N 29	O 35	S 1	0	1
4	FN	22	Total 166	C 101	N 29	O 35	S 1	0	1
4	FO	22	Total 166	C 101	N 29	O 35	S 1	0	1
4	FP	22	Total 166	C 101	N 29	O 35	S 1	0	1
4	FQ	22	Total 166	C 101	N 29	O 35	S 1	0	1
4	FR	22	Total 166	C 101	N 29	O 35	S 1	0	1
4	FS	22	Total 166	C 101	N 29	O 35	S 1	0	1
4	FT	22	Total 166	C 101	N 29	O 35	S 1	0	1
4	FU	22	Total 166	C 101	N 29	O 35	S 1	0	1
4	FV	22	Total 166	C 101	N 29	O 35	S 1	0	1

*Continued on next page...*



*Continued from previous page...*

Mol	Chain	Residues	Atoms					AltConf	Trace
			Total	C	N	O	S		
4	FW	22	Total 166	C 101	N 29	O 35	S 1	0	1
4	FX	22	Total 166	C 101	N 29	O 35	S 1	0	1
4	FY	22	Total 166	C 101	N 29	O 35	S 1	0	1
4	FZ	22	Total 166	C 101	N 29	O 35	S 1	0	1
4	Fa	22	Total 166	C 101	N 29	O 35	S 1	0	1
4	Fb	22	Total 166	C 101	N 29	O 35	S 1	0	1
4	Fc	22	Total 166	C 101	N 29	O 35	S 1	0	1
4	Fd	22	Total 166	C 101	N 29	O 35	S 1	0	1
4	Fe	22	Total 166	C 101	N 29	O 35	S 1	0	1
4	Ff	22	Total 166	C 101	N 29	O 35	S 1	0	1
4	Fg	22	Total 166	C 101	N 29	O 35	S 1	0	1
4	Fh	22	Total 166	C 101	N 29	O 35	S 1	0	1
4	Fi	22	Total 166	C 101	N 29	O 35	S 1	0	1
4	Fj	22	Total 166	C 101	N 29	O 35	S 1	0	1
4	Fk	22	Total 166	C 101	N 29	O 35	S 1	0	1
4	Fl	22	Total 166	C 101	N 29	O 35	S 1	0	1
4	Fm	22	Total 166	C 101	N 29	O 35	S 1	0	1
4	Fn	22	Total 166	C 101	N 29	O 35	S 1	0	1
4	Fo	22	Total 166	C 101	N 29	O 35	S 1	0	1
4	Fp	22	Total 166	C 101	N 29	O 35	S 1	0	1
4	Fq	22	Total 166	C 101	N 29	O 35	S 1	0	1

*Continued on next page...*

*Continued from previous page...*

Mol	Chain	Residues	Atoms					AltConf	Trace
4	Fr	22	Total 166	C 101	N 29	O 35	S 1	0	1
4	Fs	22	Total 166	C 101	N 29	O 35	S 1	0	1
4	Ft	22	Total 166	C 101	N 29	O 35	S 1	0	1
4	Fu	22	Total 166	C 101	N 29	O 35	S 1	0	1
4	Fv	22	Total 166	C 101	N 29	O 35	S 1	0	1
4	Fw	22	Total 166	C 101	N 29	O 35	S 1	0	1
4	Fx	22	Total 166	C 101	N 29	O 35	S 1	0	1

### 3 Residue-property plots [i](#)

These plots are drawn for all protein, RNA, DNA and oligosaccharide chains in the entry. The first graphic for a chain summarises the proportions of the various outlier classes displayed in the second graphic. The second graphic shows the sequence view annotated by issues in geometry and atom inclusion in map density. Residues are color-coded according to the number of geometric quality criteria for which they contain at least one outlier: green = 0, yellow = 1, orange = 2 and red = 3 or more. A red diamond above a residue indicates a poor fit to the EM map for this residue (all-atom inclusion < 40%). Stretches of 2 or more consecutive residues without any outlier are shown as a green connector. Residues present in the sample, but not in the model, are shown in grey.

- Molecule 1: VP1

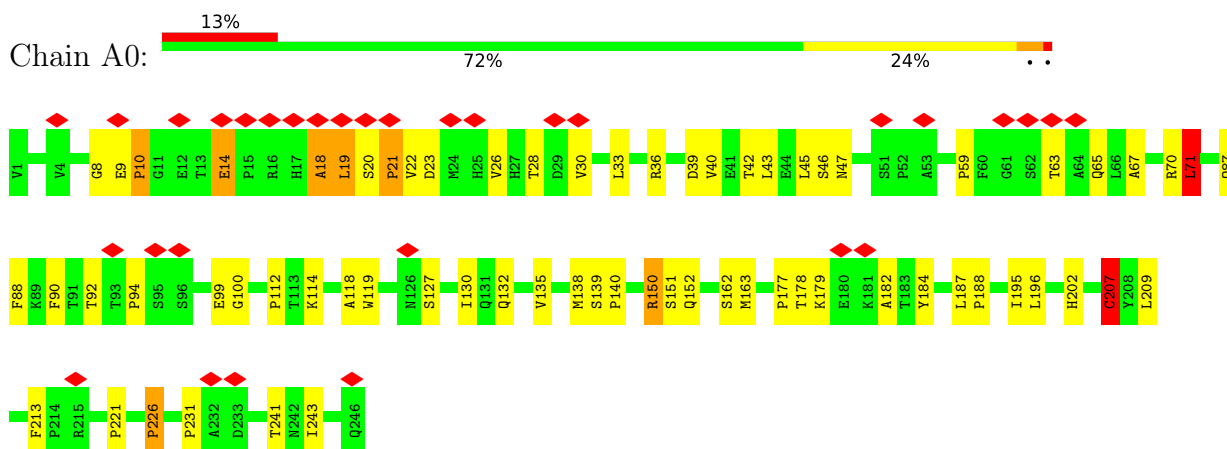

- Molecule 1: VP1

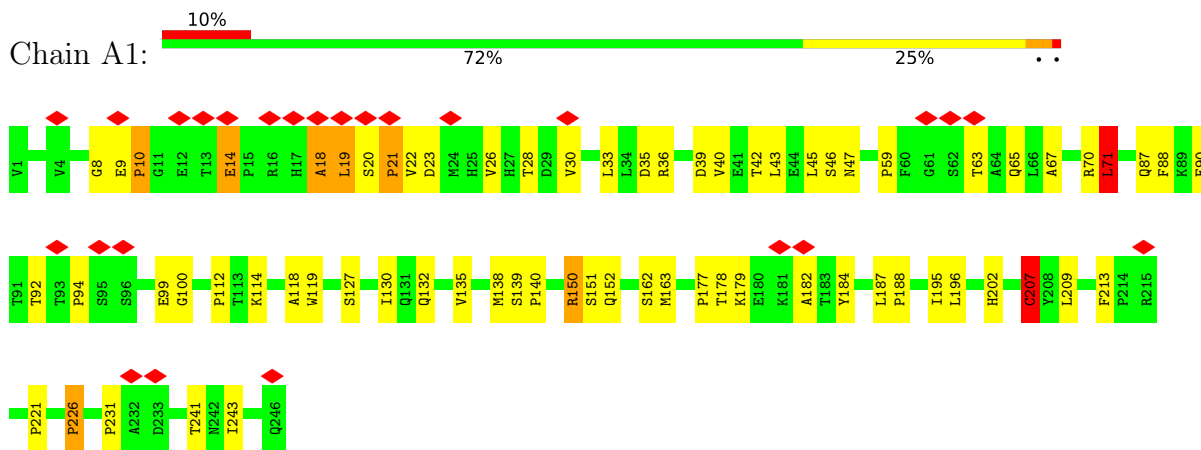

- Molecule 1: VP1

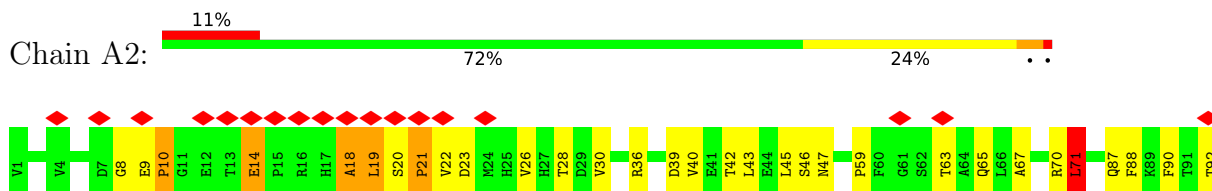

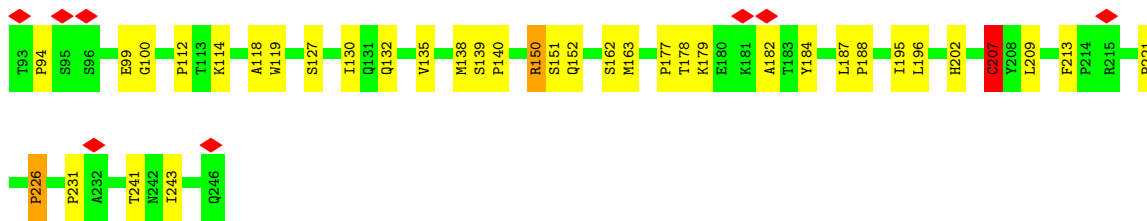

• Molecule 1: VP1

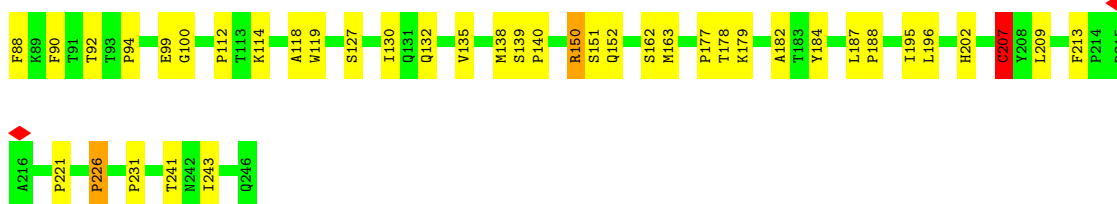
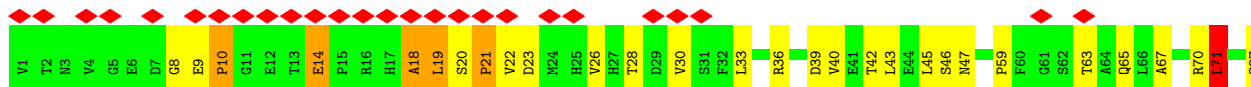
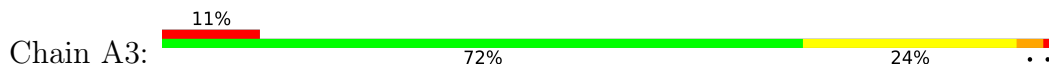

• Molecule 1: VP1

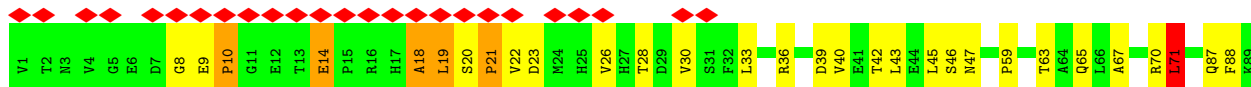
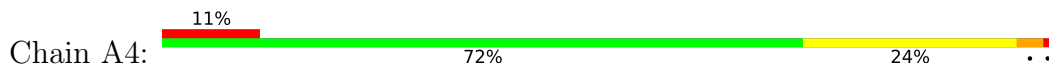

• Molecule 1: VP1

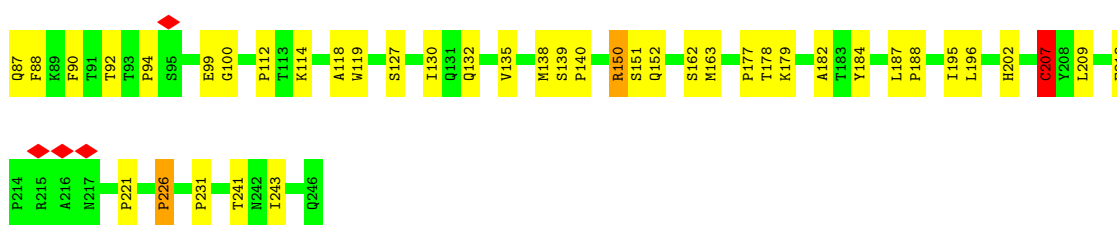
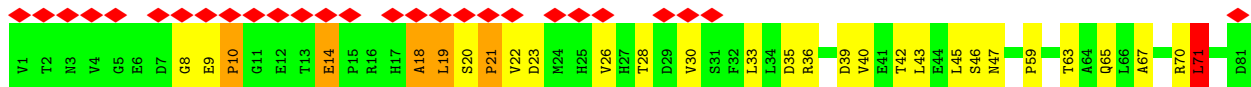
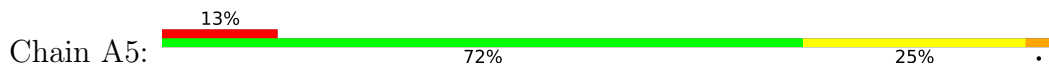

• Molecule 1: VP1

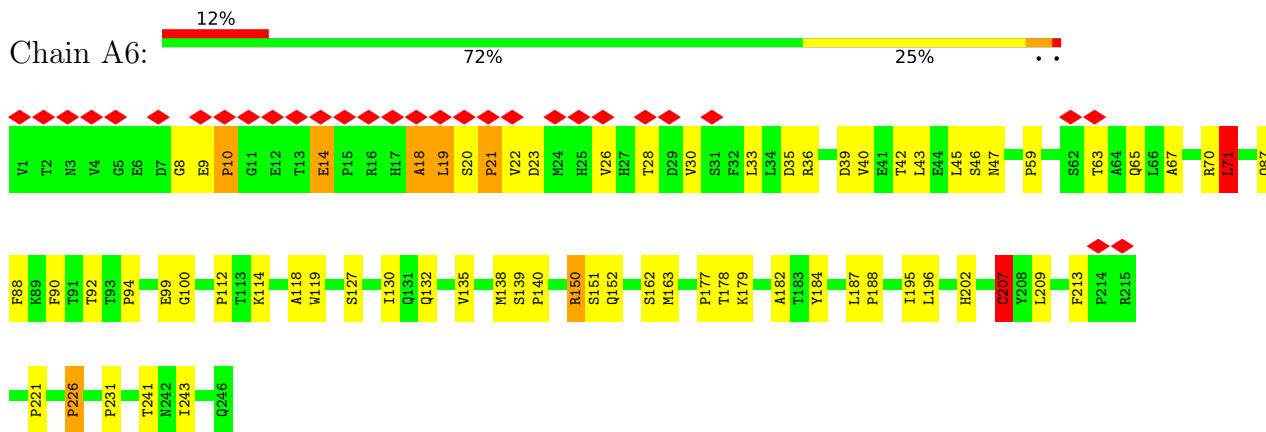

• Molecule 1: VP1

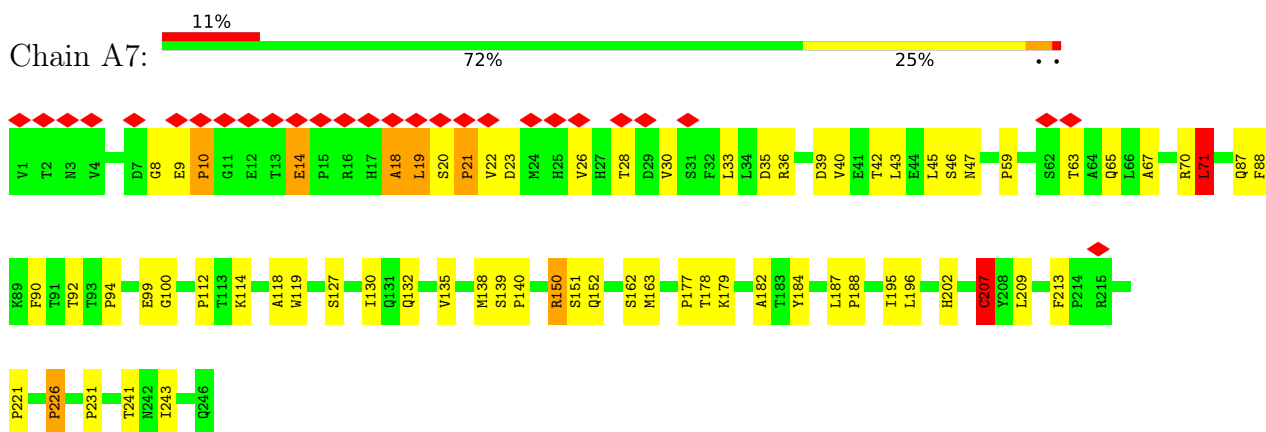

• Molecule 1: VP1

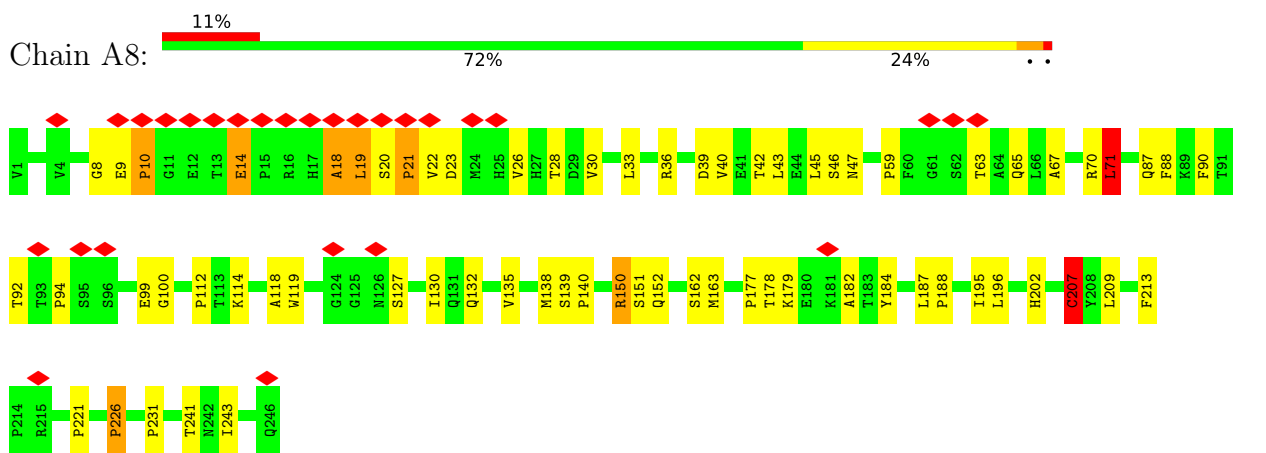

• Molecule 1: VP1

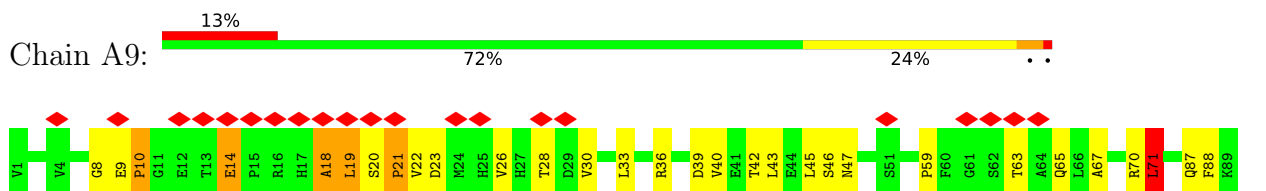

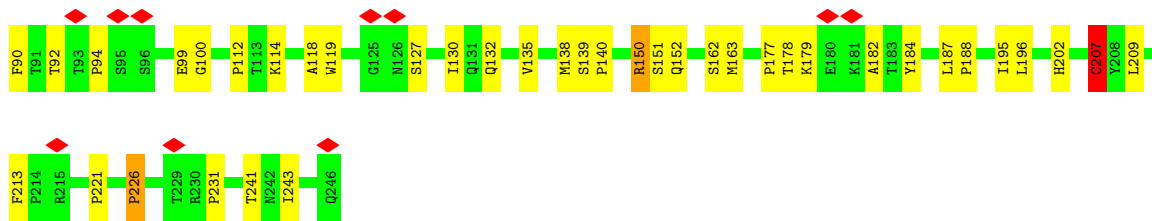

• Molecule 1: VP1

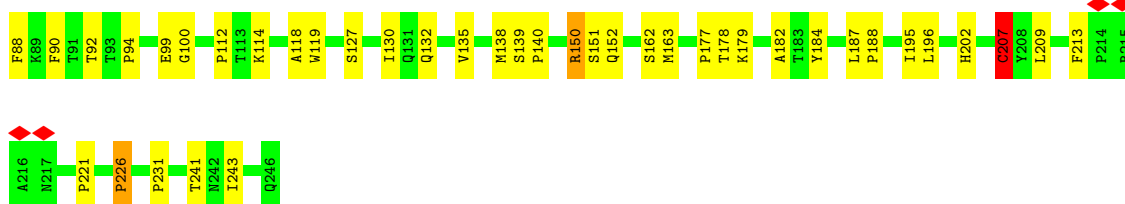
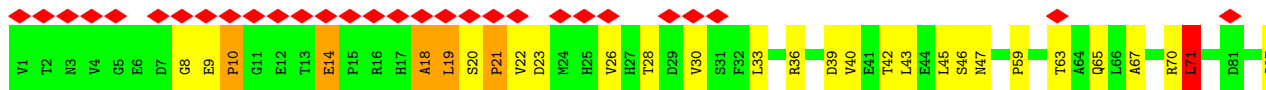
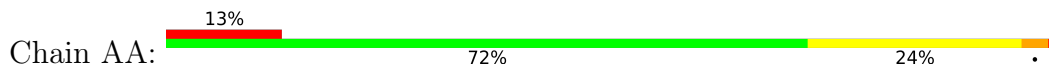

• Molecule 1: VP1

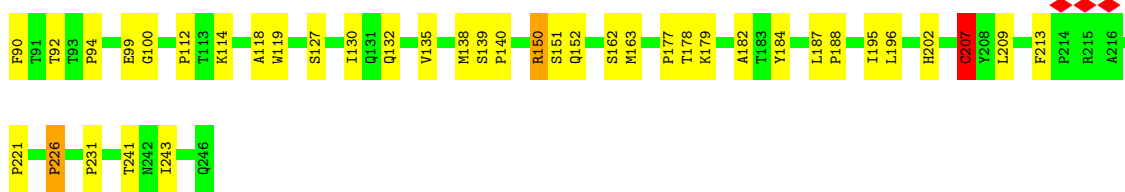
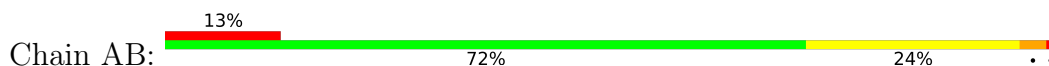

• Molecule 1: VP1

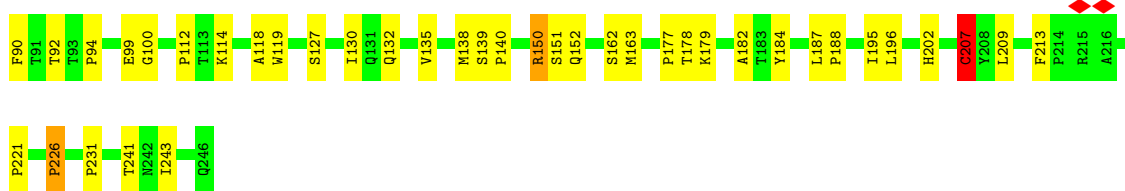
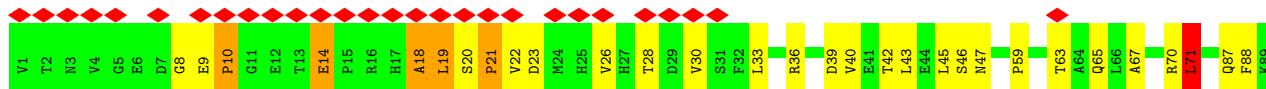
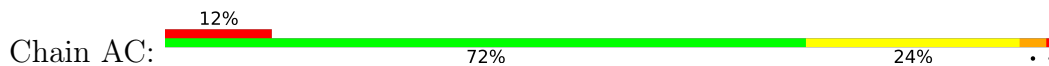

• Molecule 1: VP1

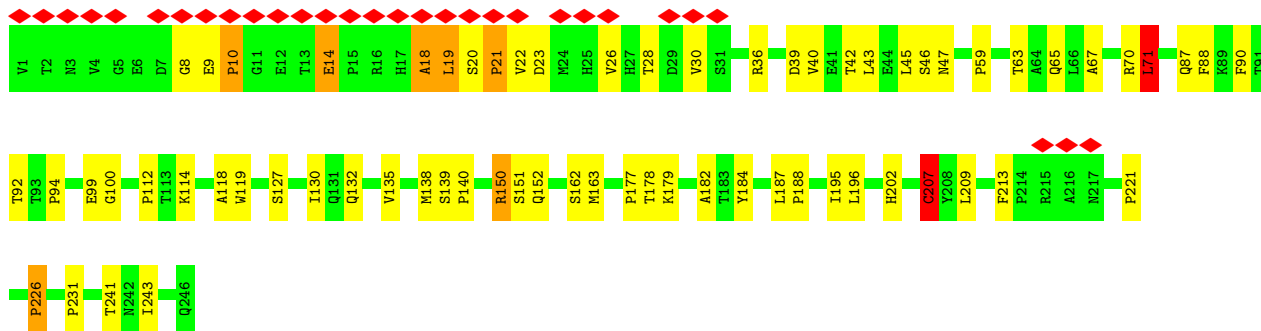
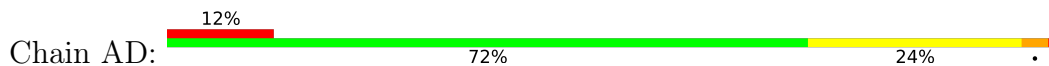

• Molecule 1: VP1

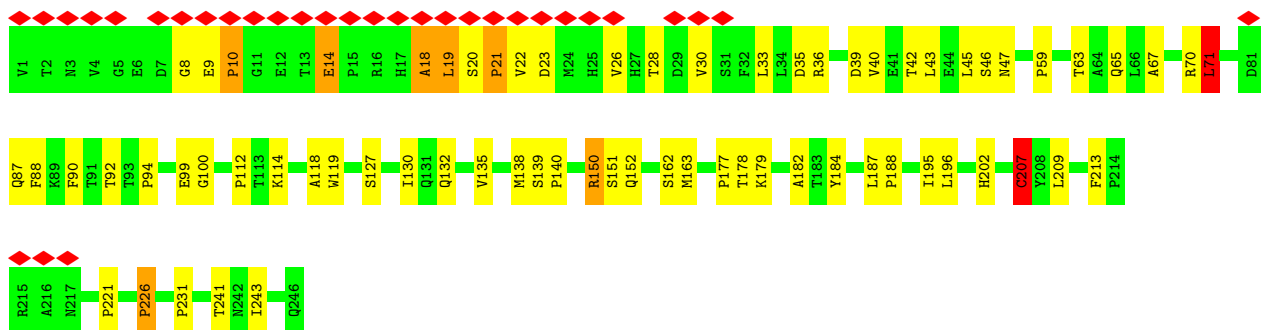
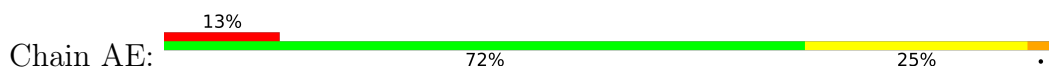

• Molecule 1: VP1

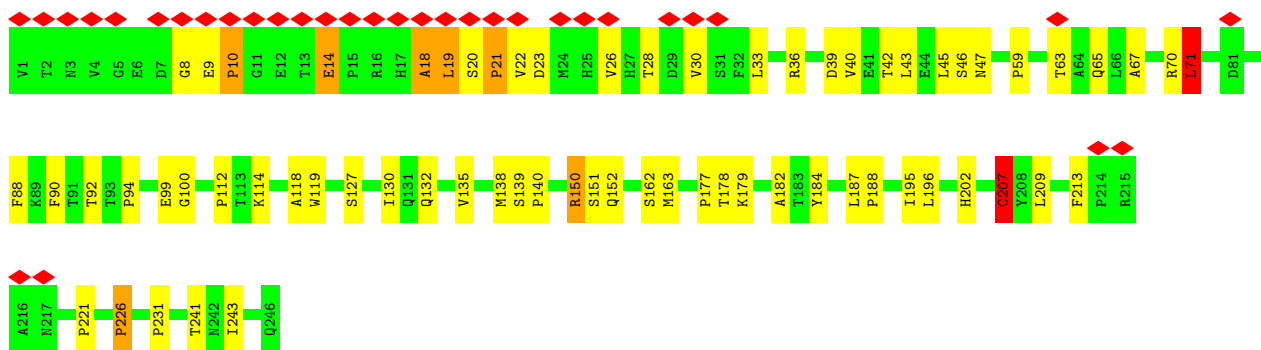

• Molecule 1: VP1

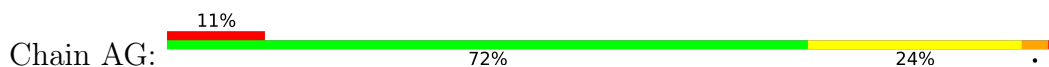

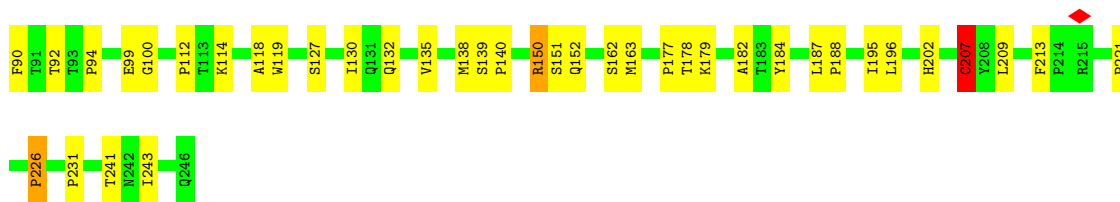

• Molecule 1: VP1

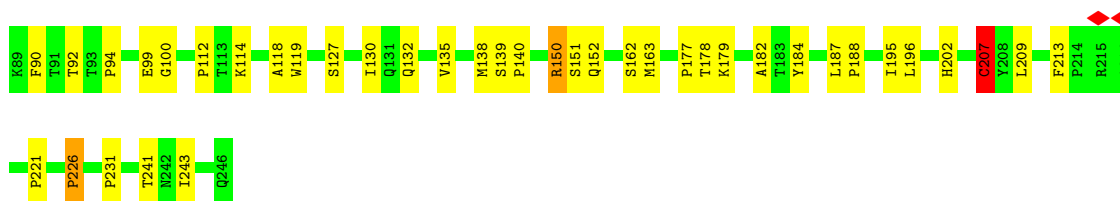
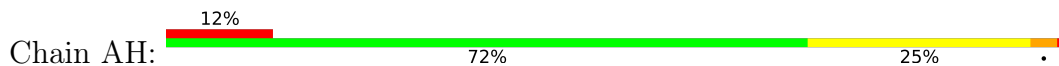

• Molecule 1: VP1

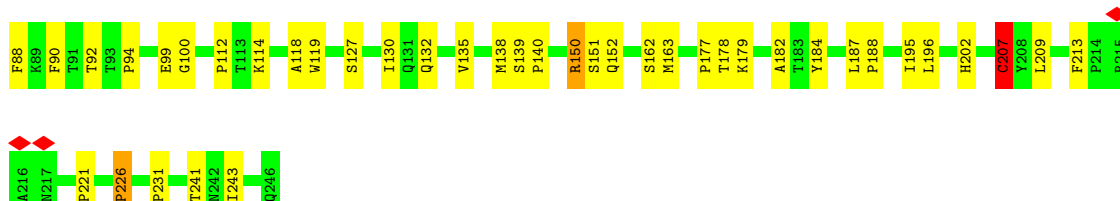
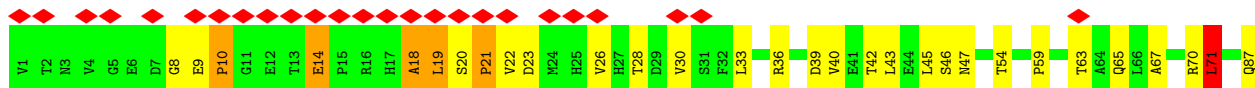

• Molecule 1: VP1

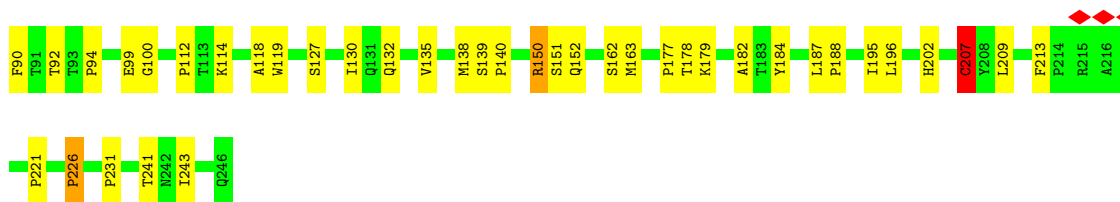
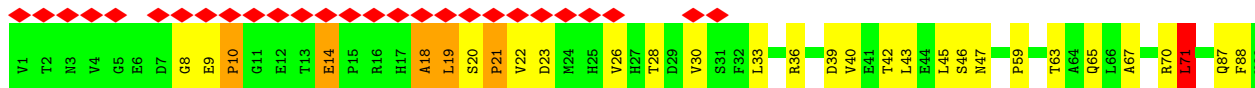



• Molecule 1: VP1

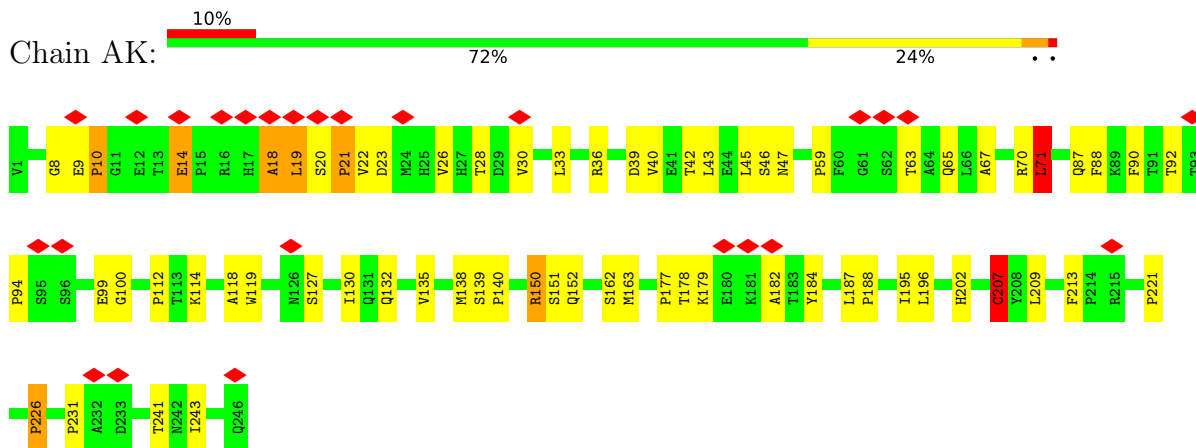

• Molecule 1: VP1

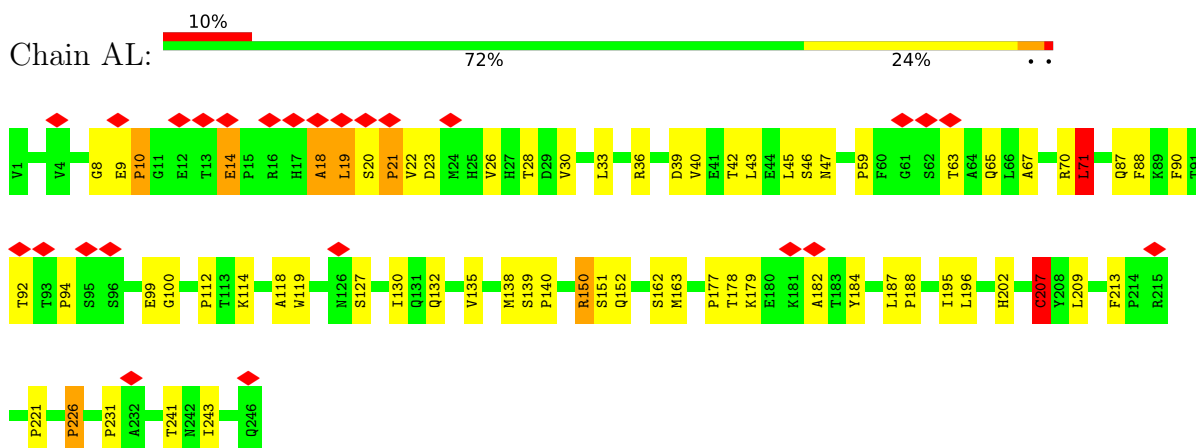

• Molecule 1: VP1

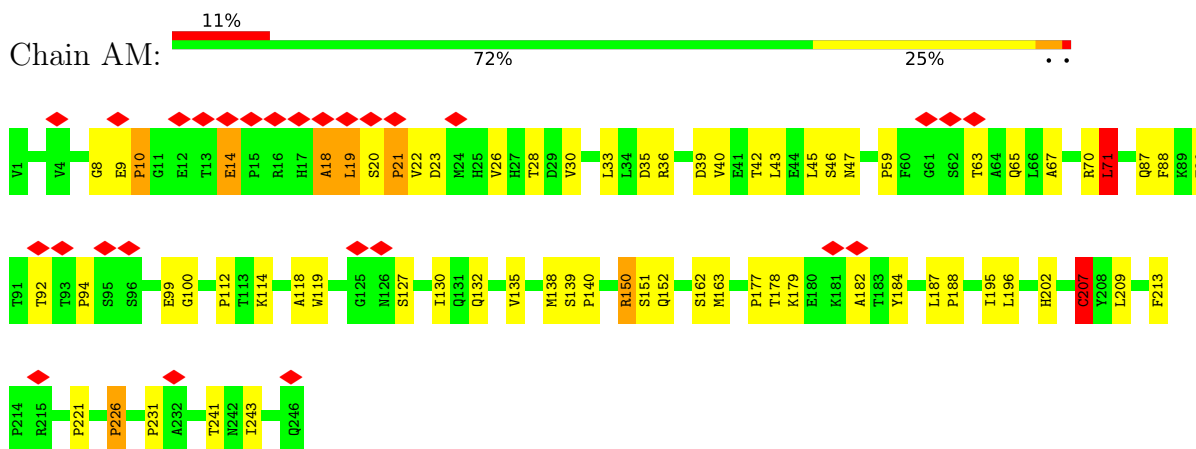

• Molecule 1: VP1



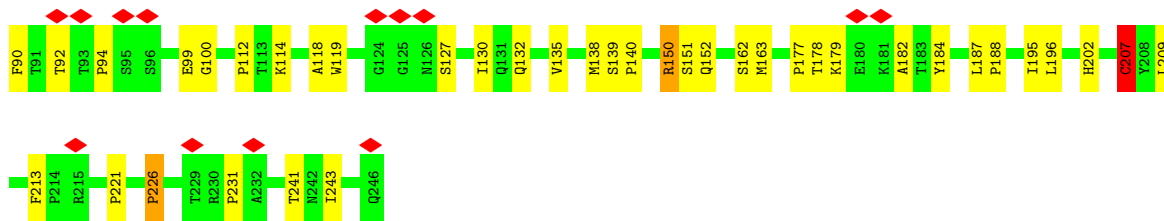

• Molecule 1: VP1

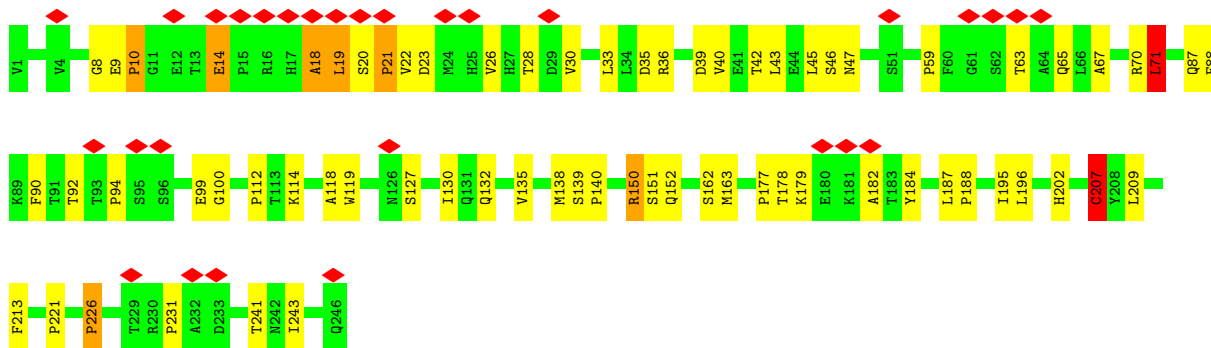
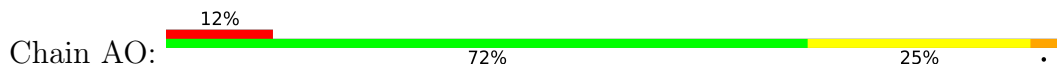

• Molecule 1: VP1

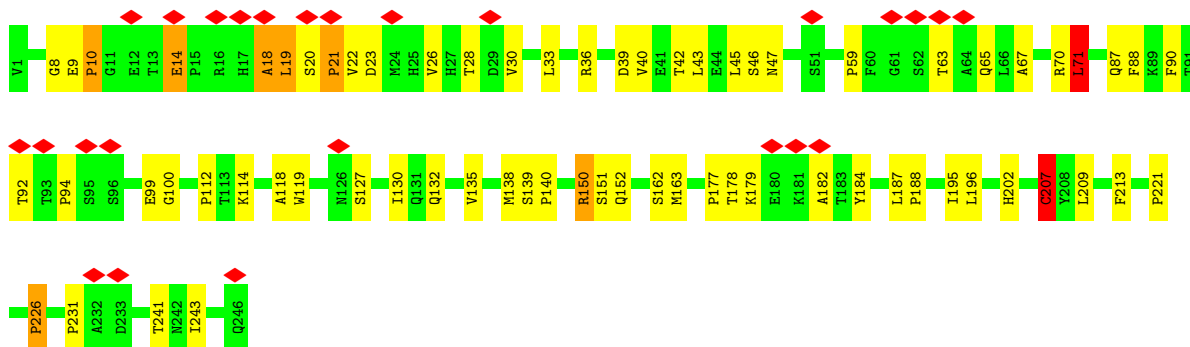
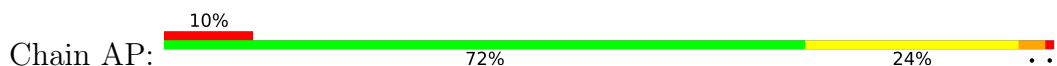

• Molecule 1: VP1

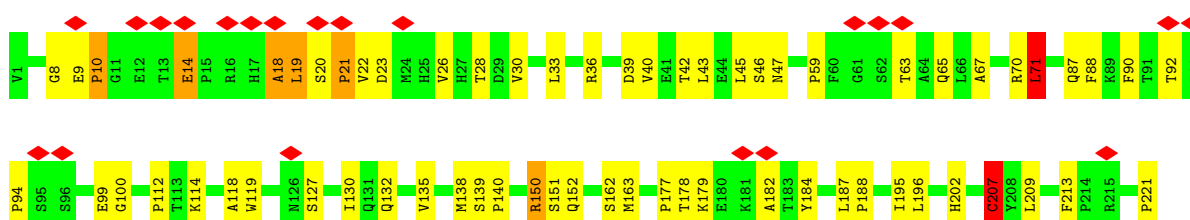

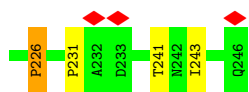

• Molecule 1: VP1

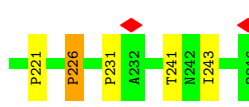
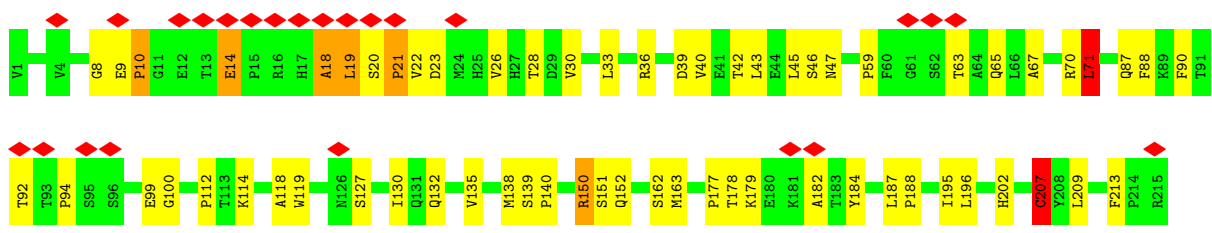
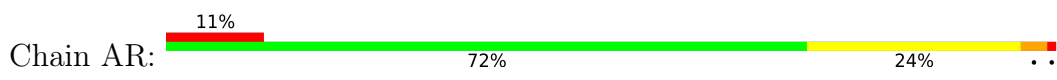

• Molecule 1: VP1

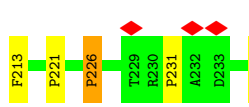
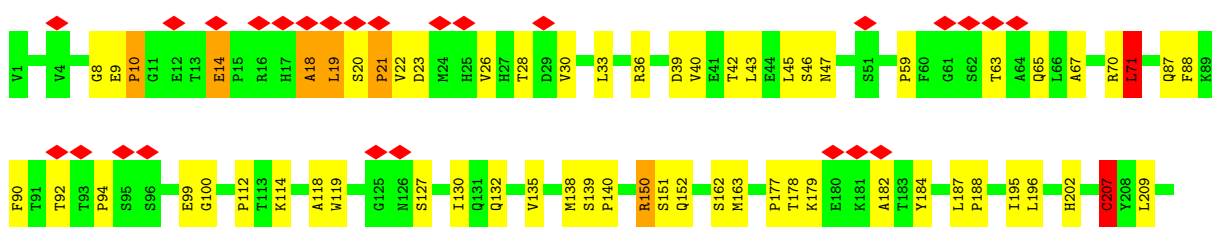
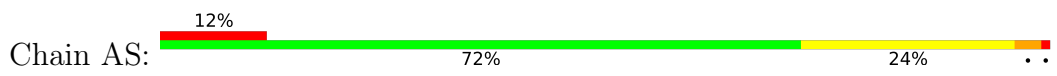

• Molecule 1: VP1

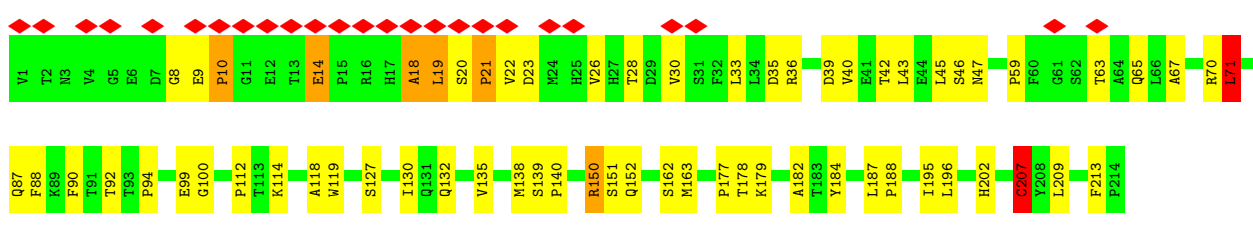
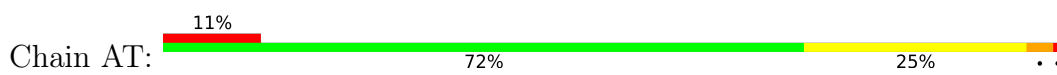

• Molecule 1: VP1

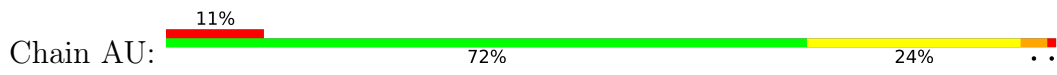

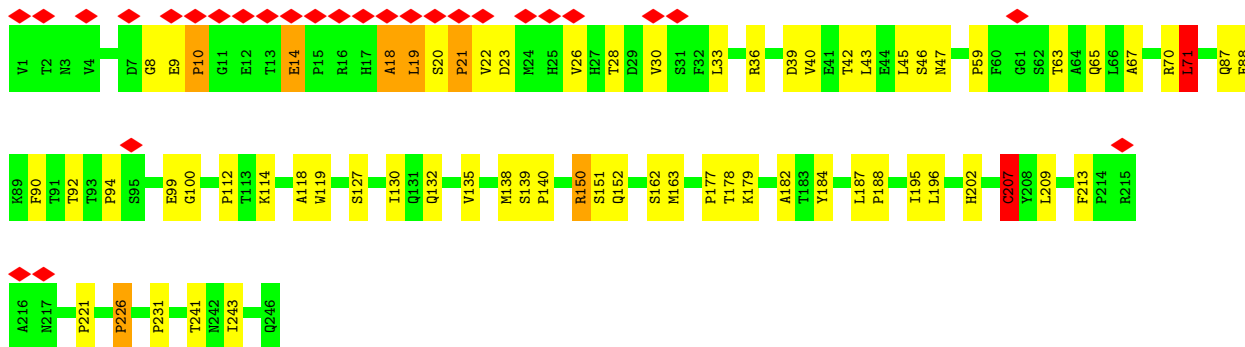

• Molecule 1: VP1

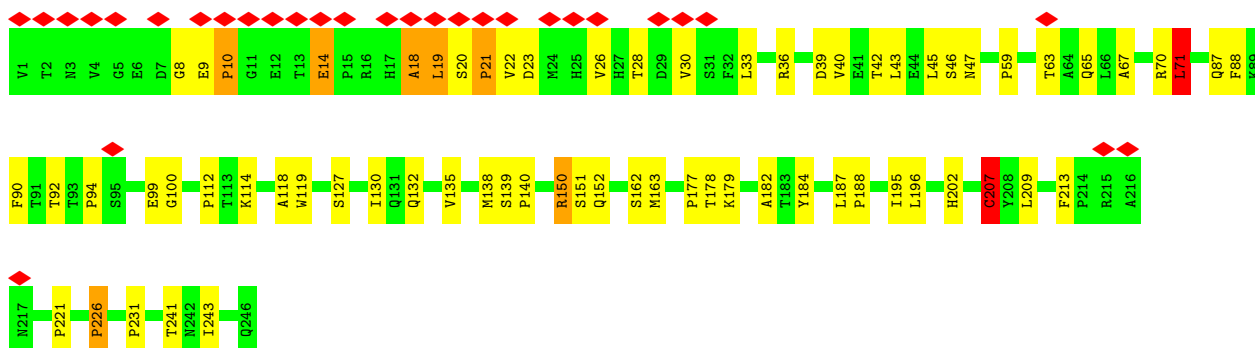
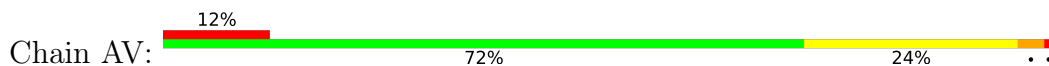

• Molecule 1: VP1

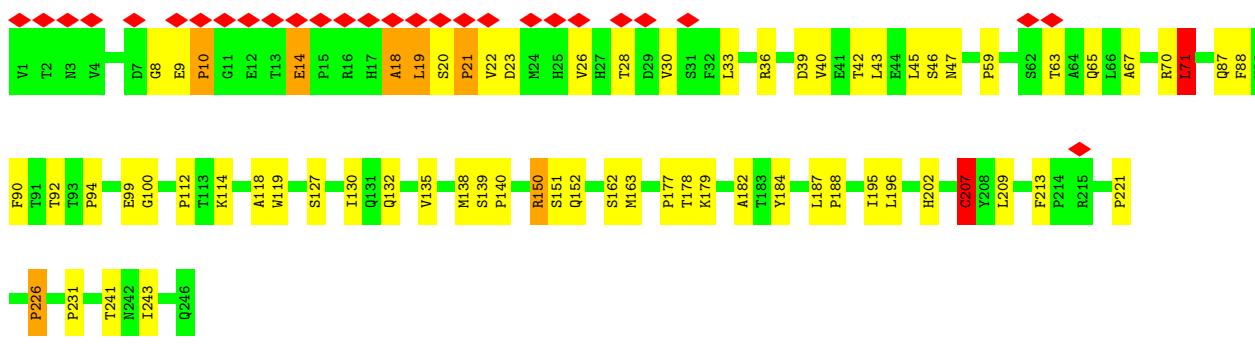
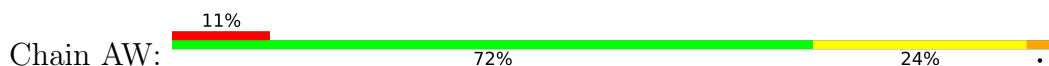

• Molecule 1: VP1

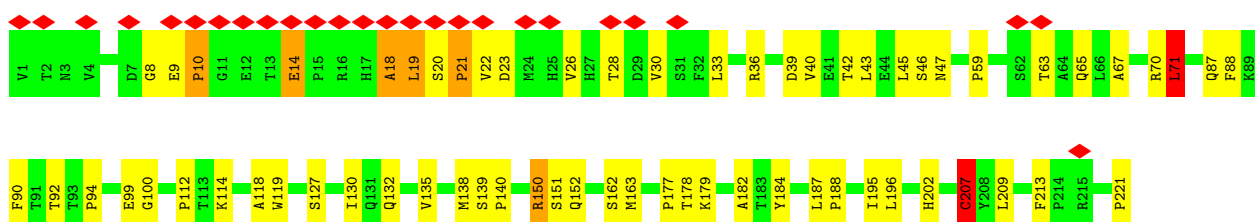



• Molecule 1: VP1

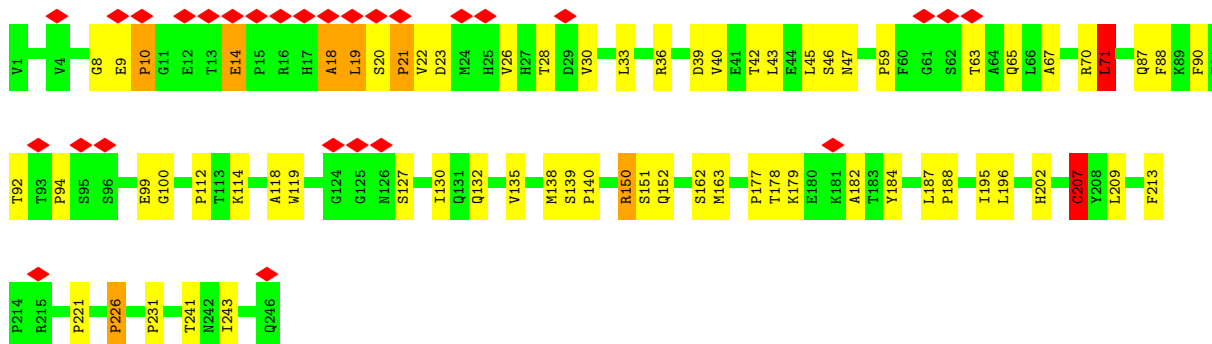
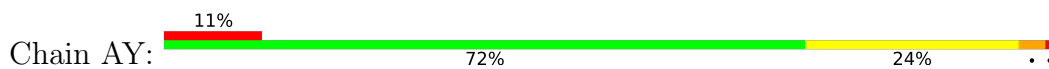

• Molecule 1: VP1

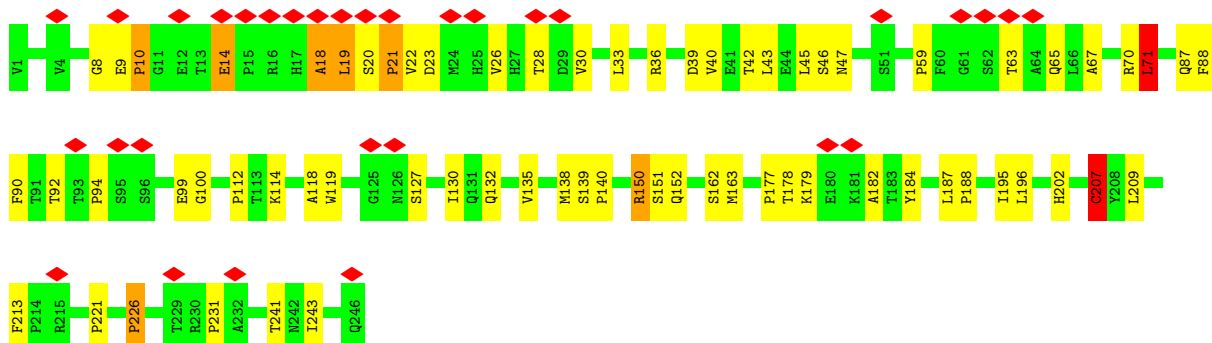
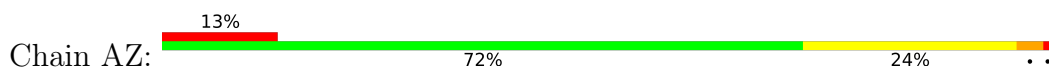

• Molecule 1: VP1

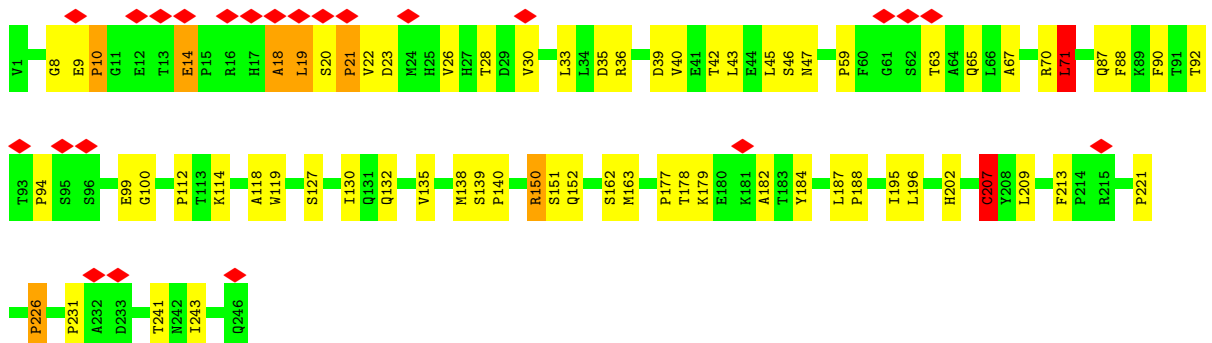
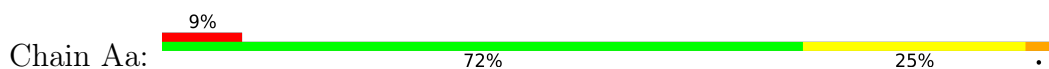

• Molecule 1: VP1

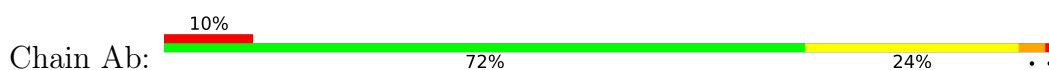

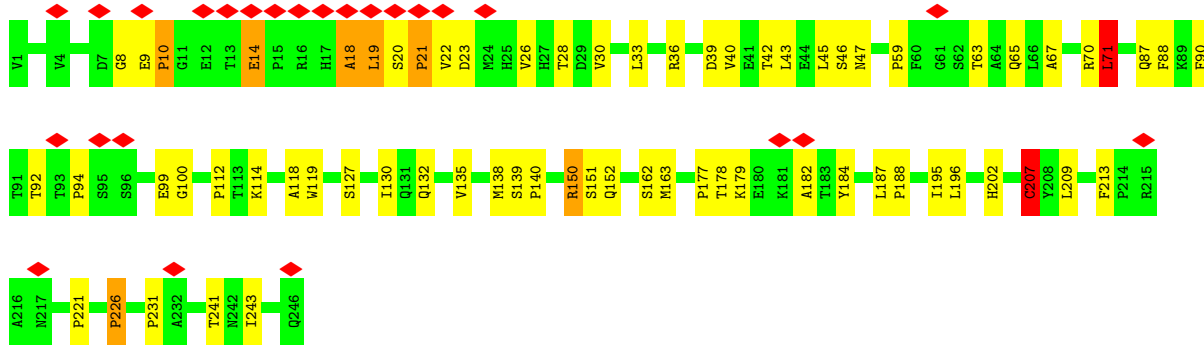

• Molecule 1: VP1

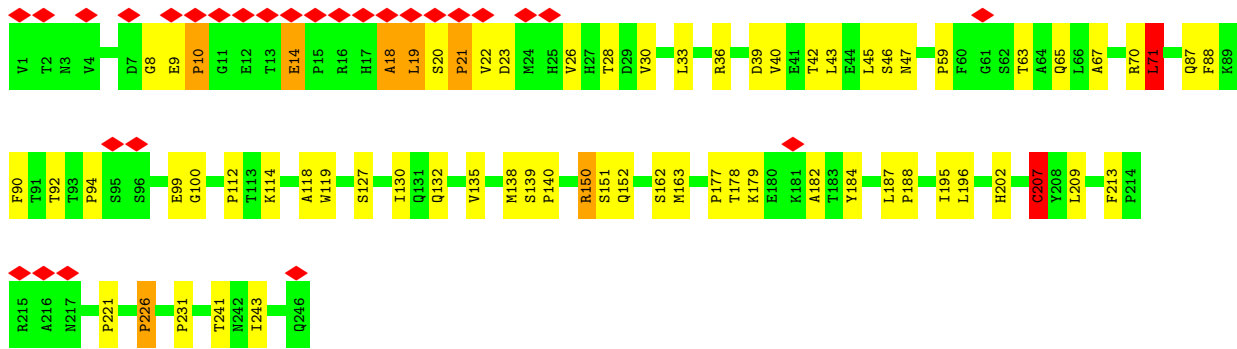
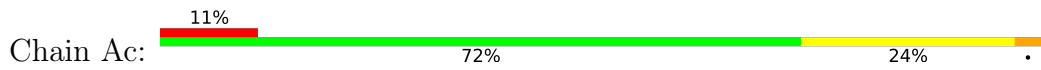

• Molecule 1: VP1

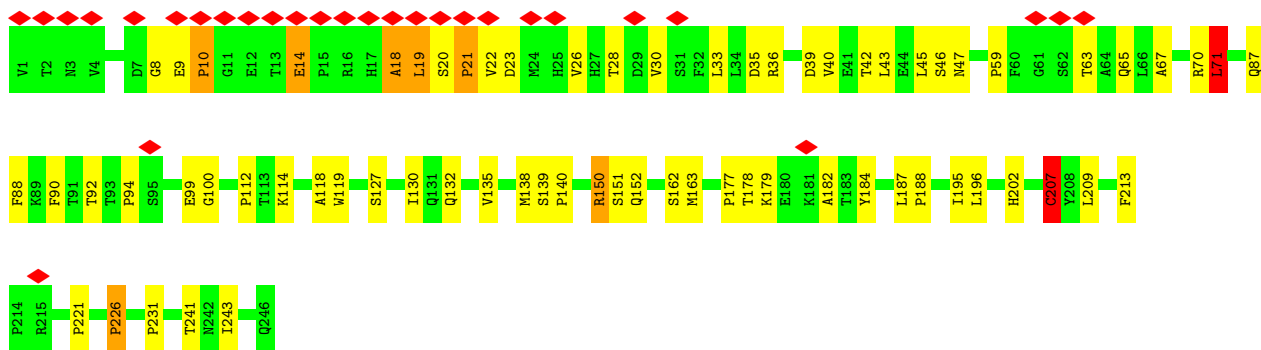
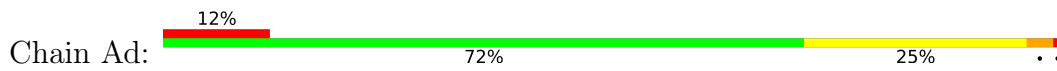

• Molecule 1: VP1

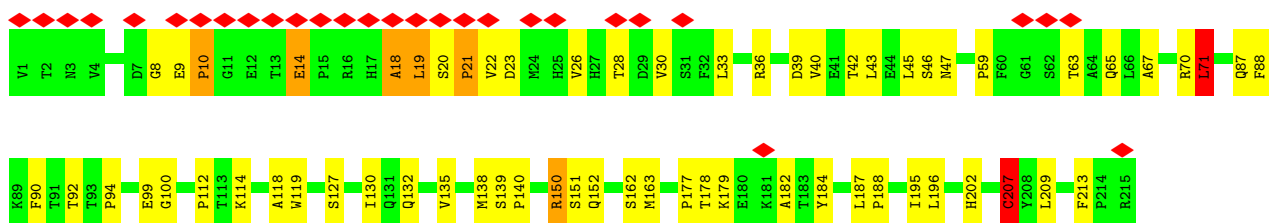
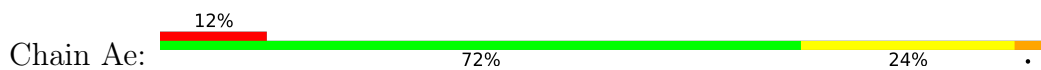



• Molecule 1: VP1

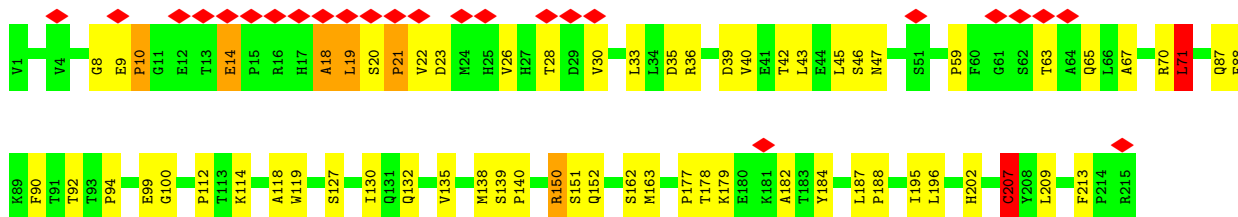

• Molecule 1: VP1

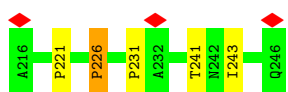
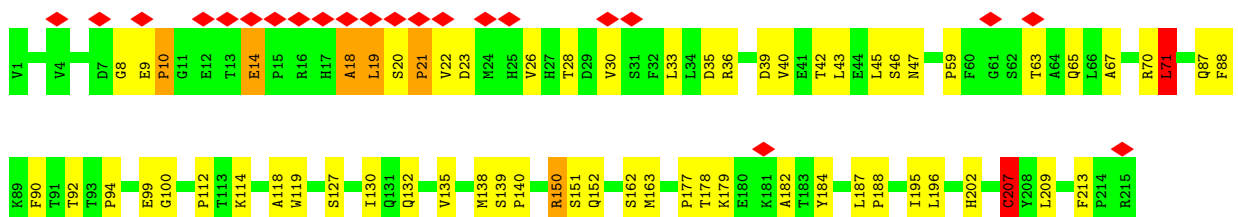
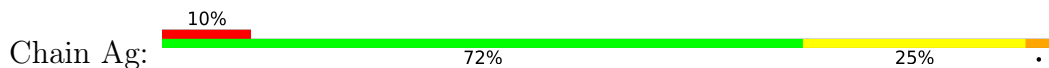

• Molecule 1: VP1

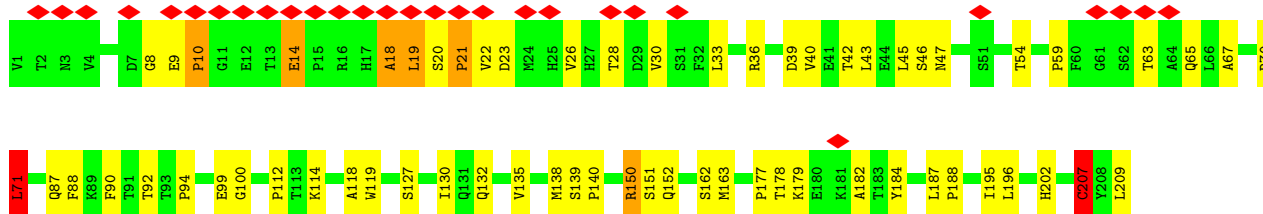
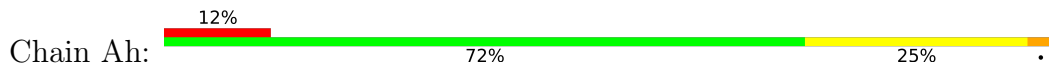

• Molecule 1: VP1



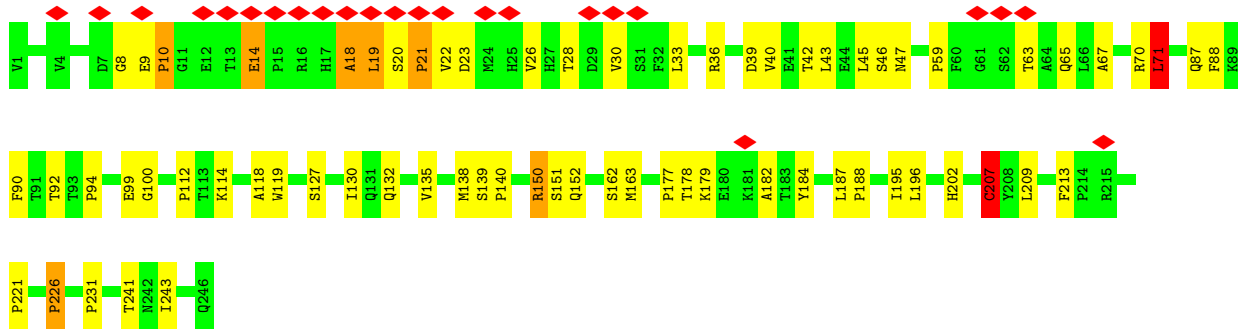

• Molecule 1: VP1

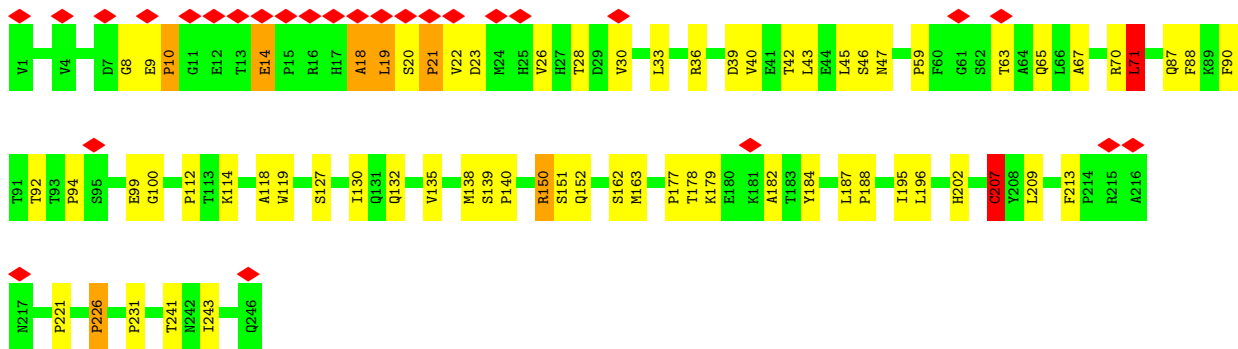
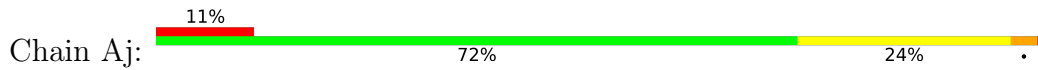

• Molecule 1: VP1

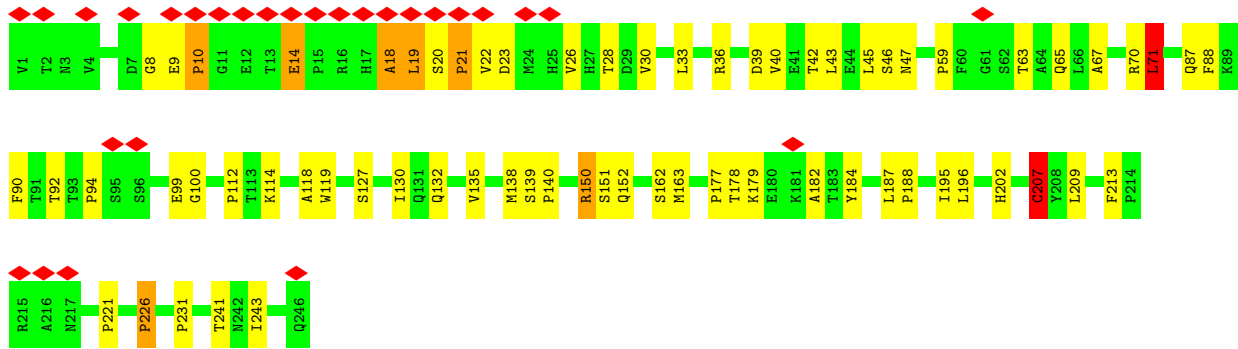
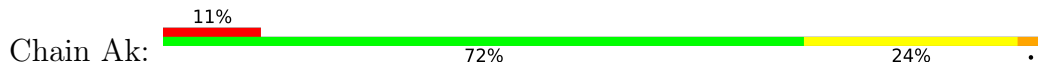

• Molecule 1: VP1

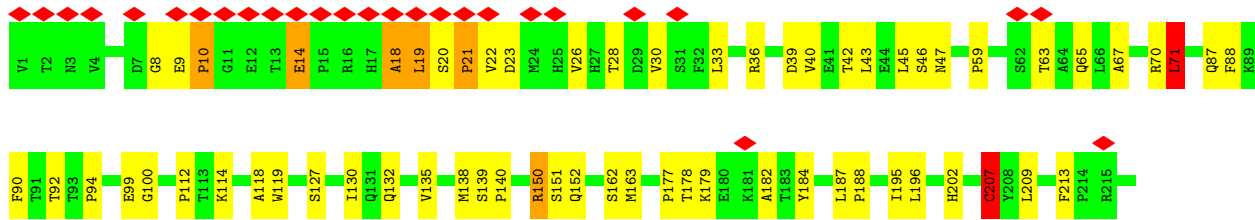
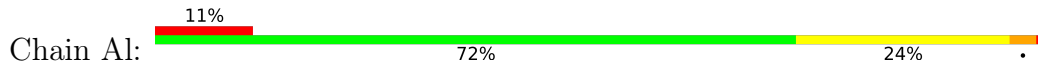



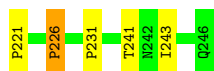

• Molecule 1: VP1

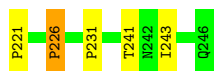
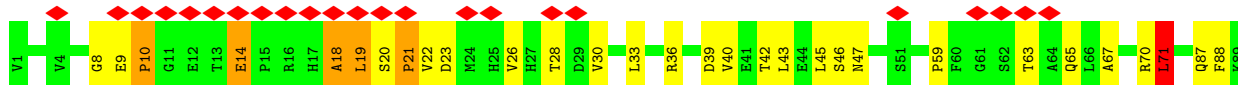
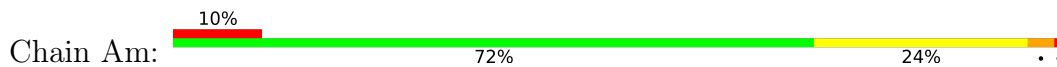

• Molecule 1: VP1

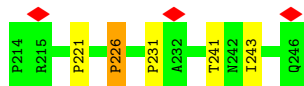
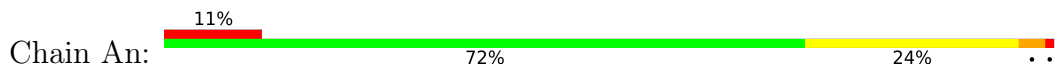

• Molecule 1: VP1

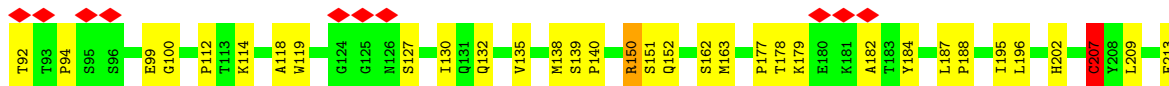
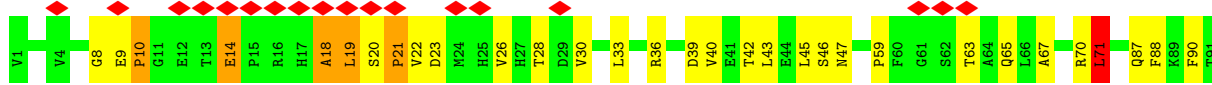

• Molecule 1: VP1

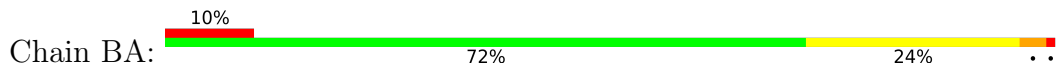

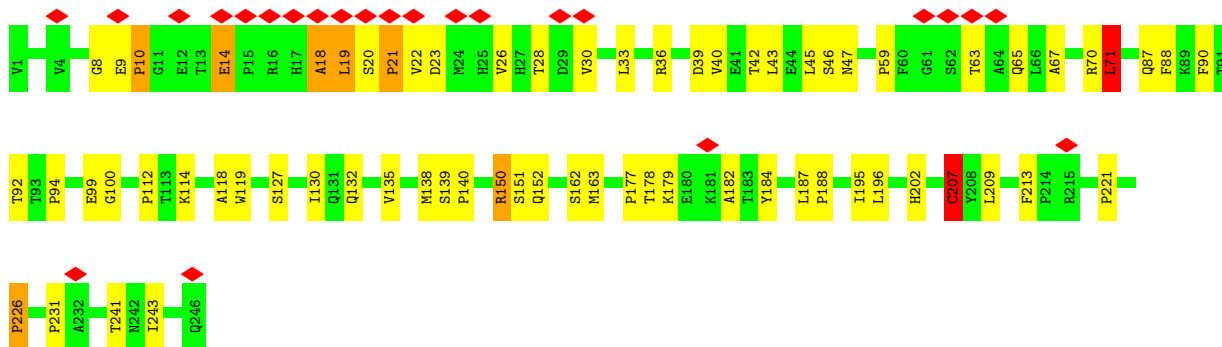

• Molecule 1: VP1

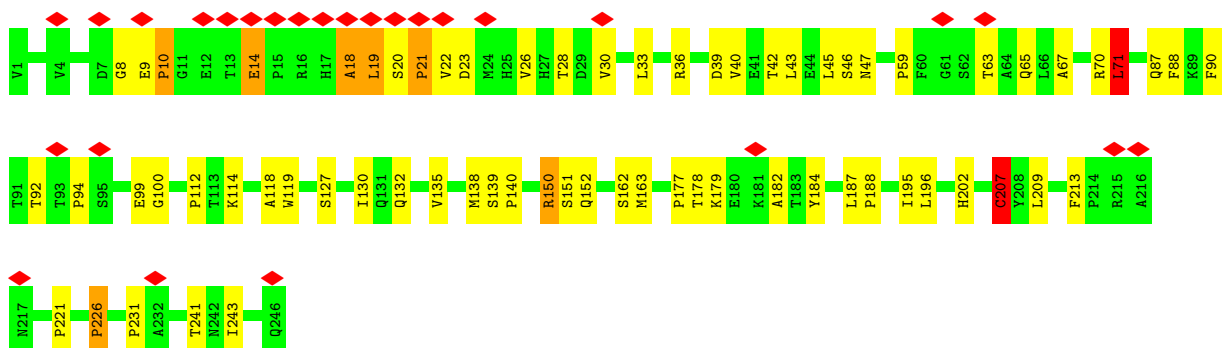
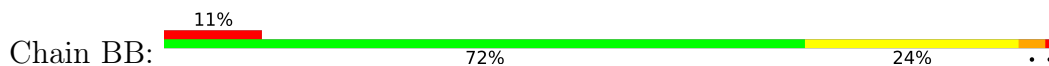

• Molecule 1: VP1

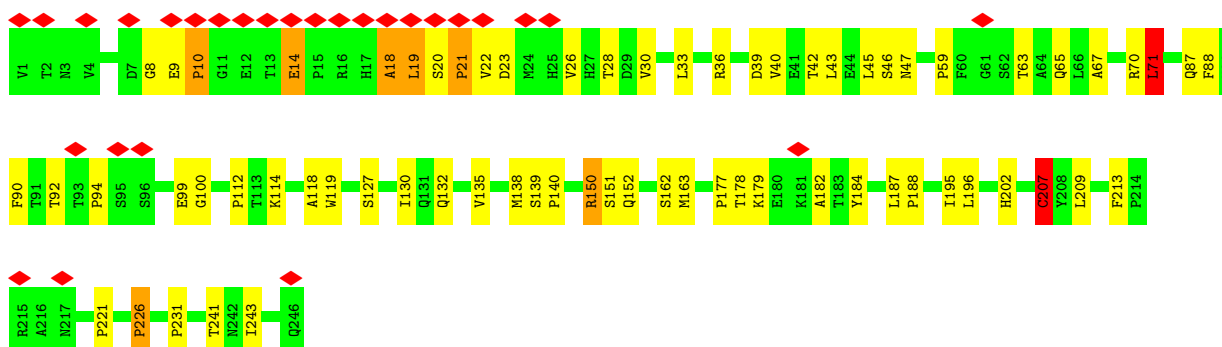
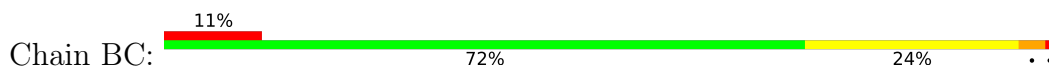

• Molecule 1: VP1

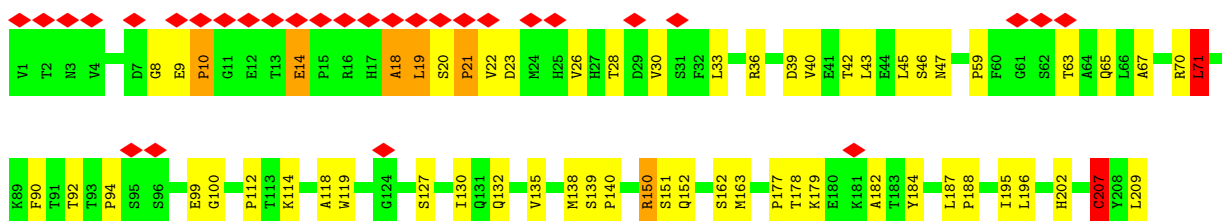
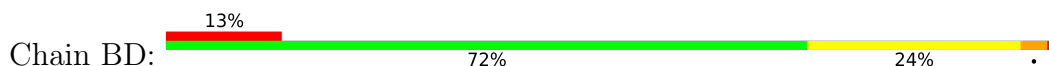



• Molecule 1: VP1

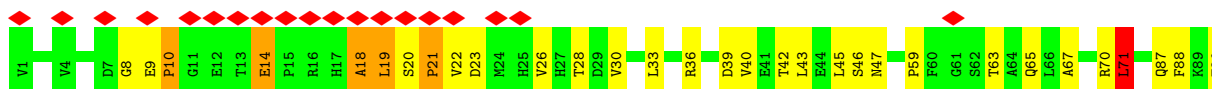
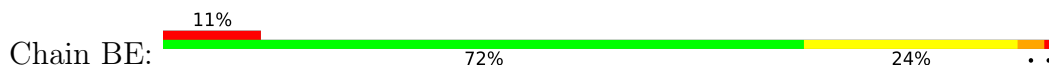

• Molecule 1: VP1

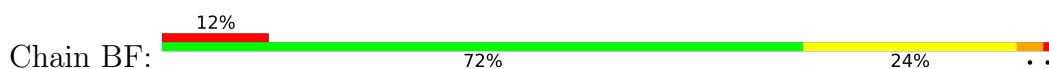

• Molecule 1: VP1

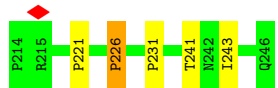
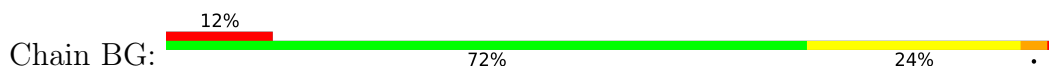

• Molecule 1: VP1

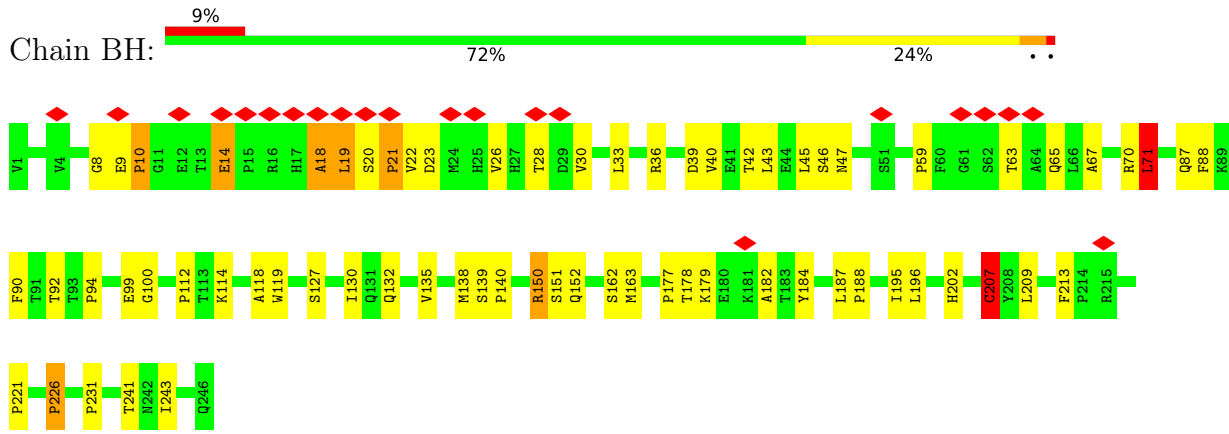

• Molecule 1: VP1

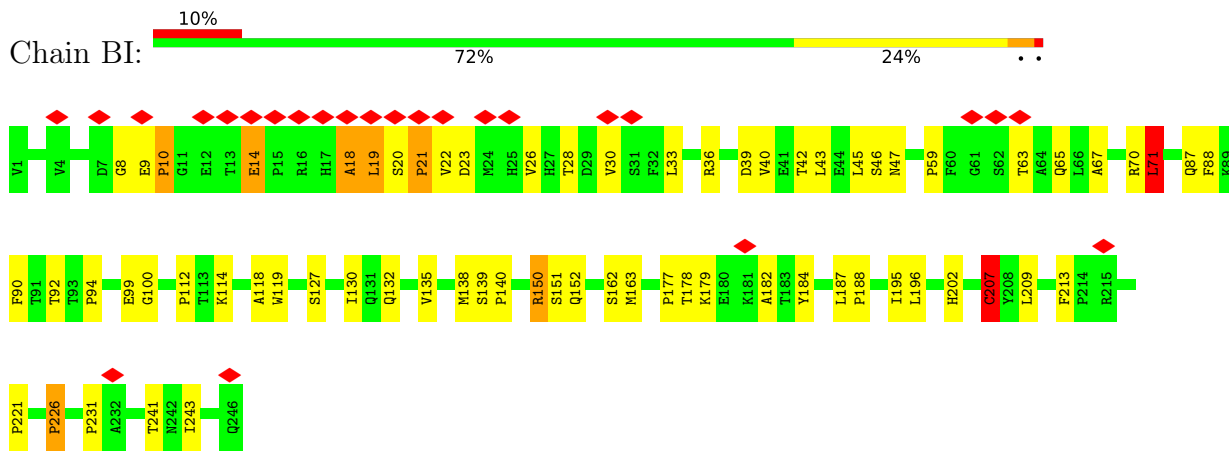

• Molecule 2: EQUINE RHINITIS A VIRUS

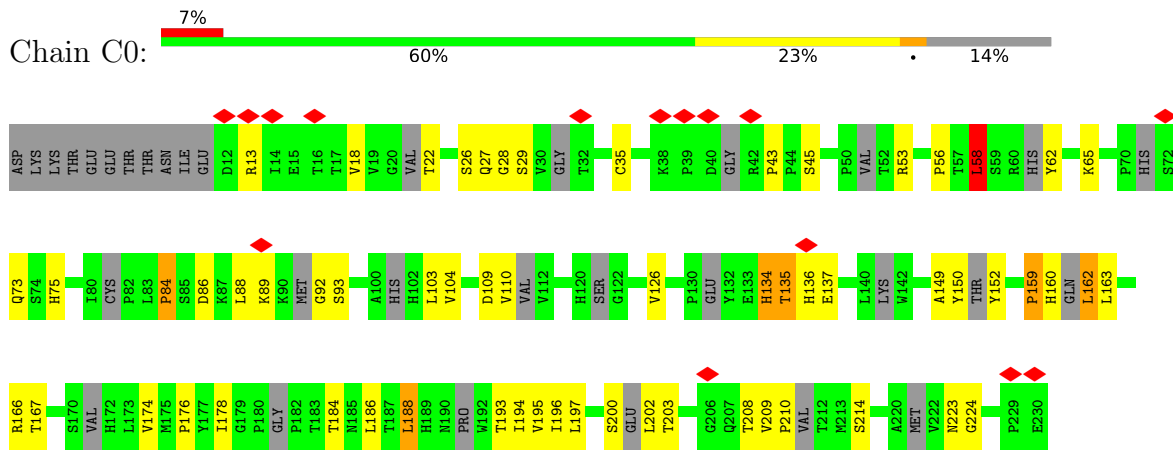

• Molecule 2: EQUINE RHINITIS A VIRUS

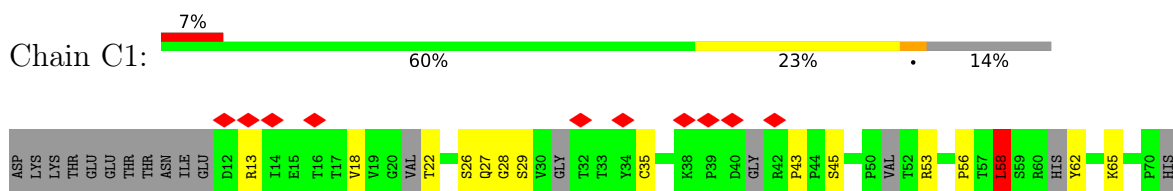

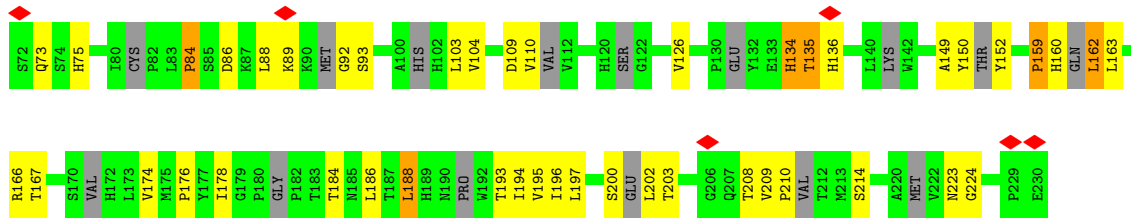

• Molecule 2: EQUINE RHINITIS A VIRUS

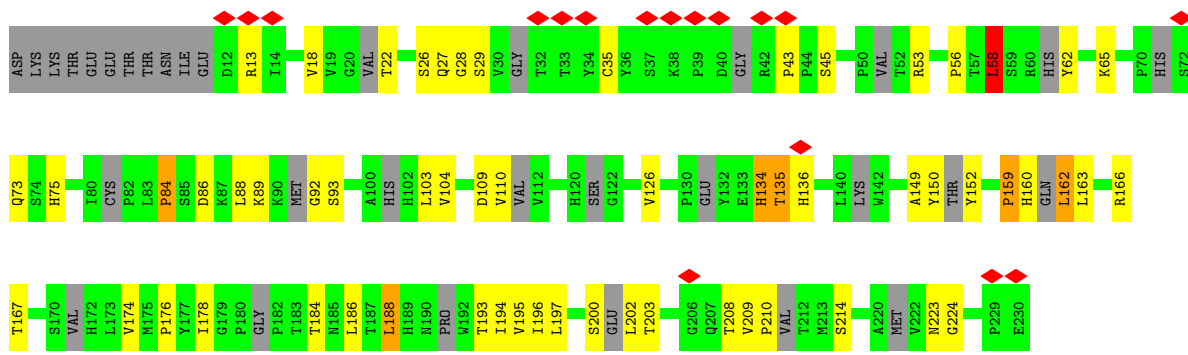

• Molecule 2: EQUINE RHINITIS A VIRUS

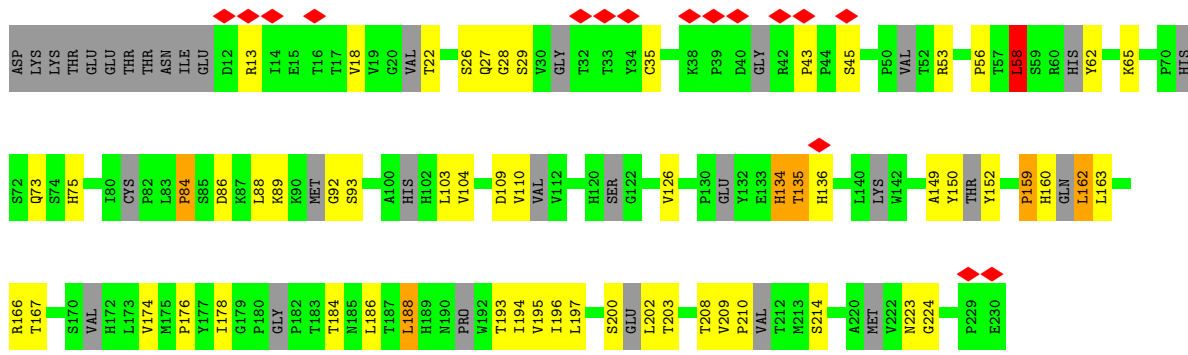

• Molecule 2: EQUINE RHINITIS A VIRUS

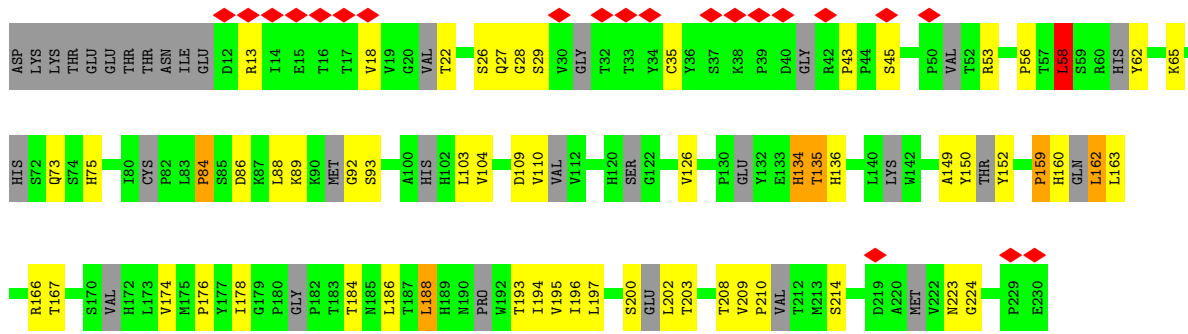

• Molecule 2: EQUINE RHINITIS A VIRUS

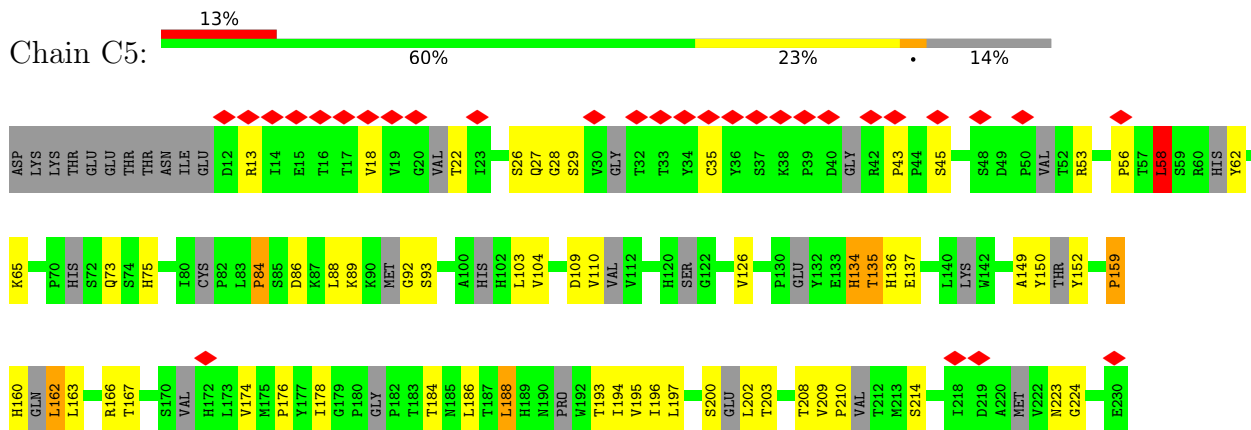

• Molecule 2: EQUINE RHINITIS A VIRUS

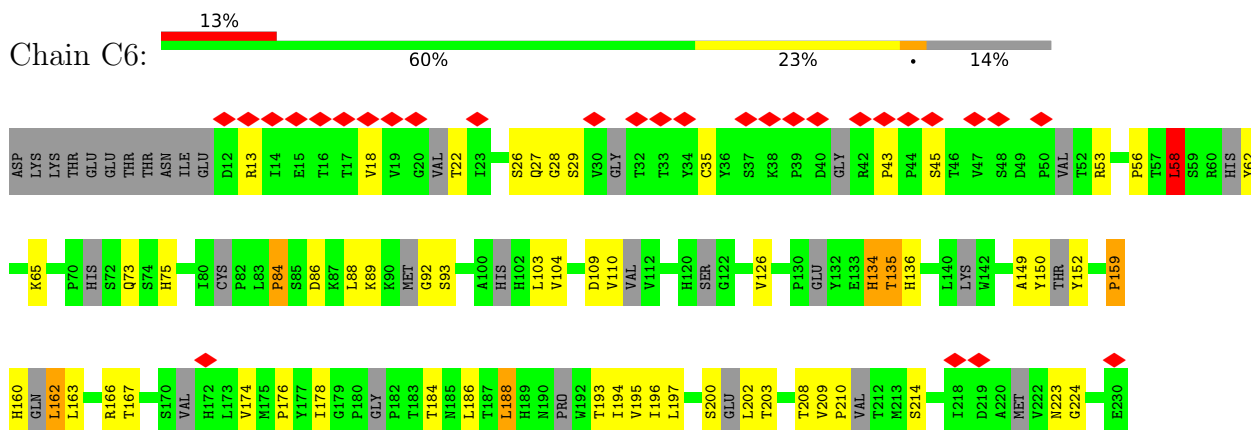

• Molecule 2: EQUINE RHINITIS A VIRUS

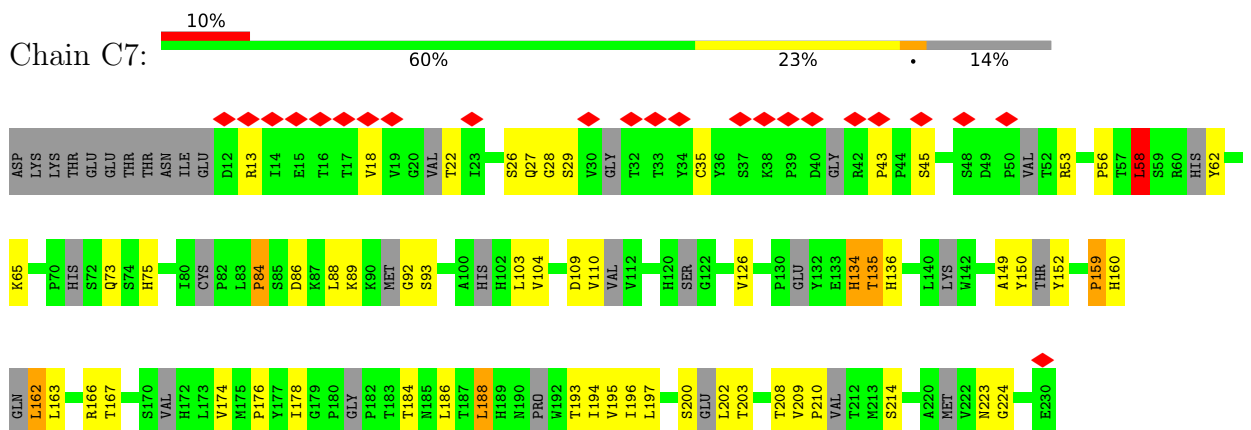

• Molecule 2: EQUINE RHINITIS A VIRUS

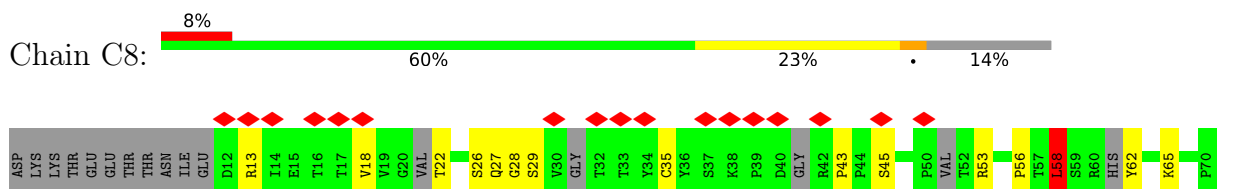

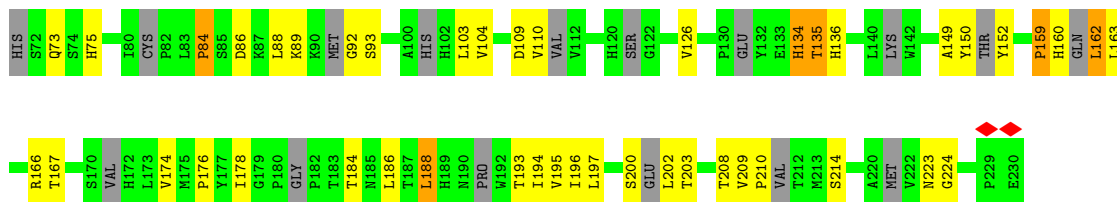

• Molecule 2: EQUINE RHINITIS A VIRUS

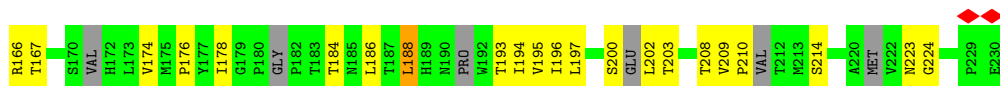
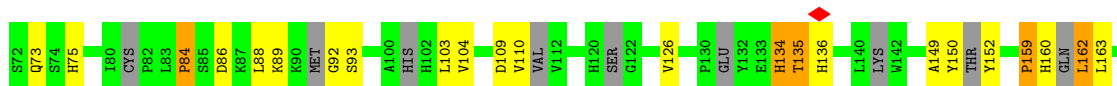
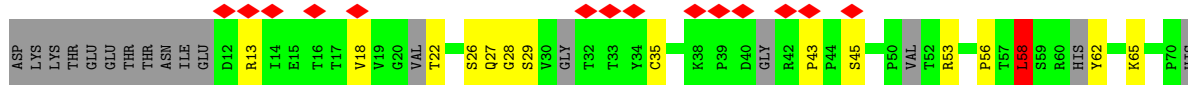

• Molecule 2: EQUINE RHINITIS A VIRUS

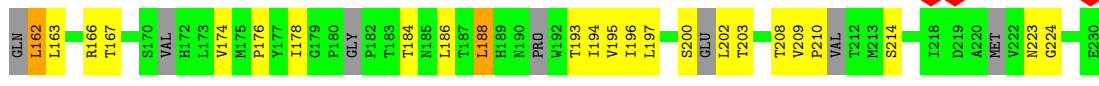
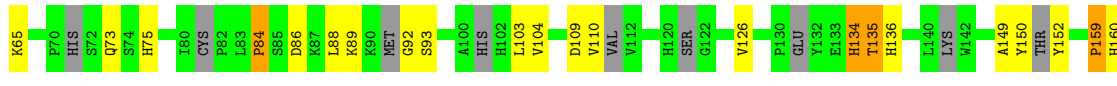
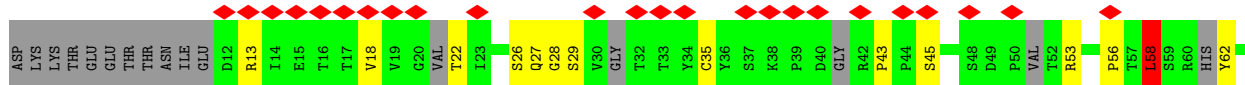

• Molecule 2: EQUINE RHINITIS A VIRUS

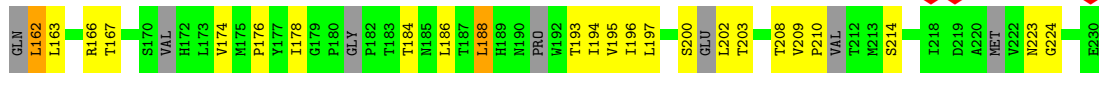
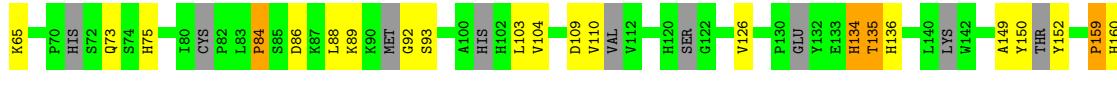
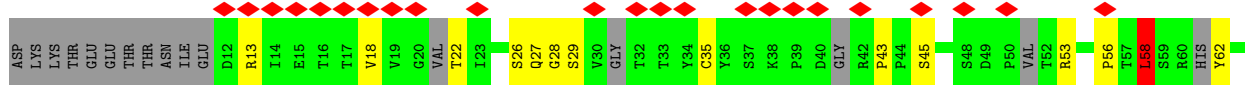

• Molecule 2: EQUINE RHINITIS A VIRUS

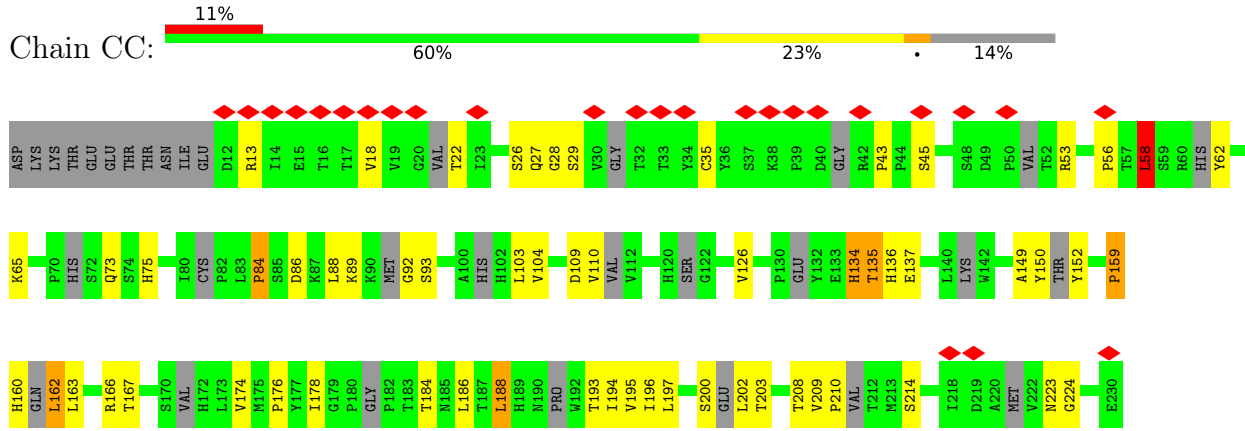

• Molecule 2: EQUINE RHINITIS A VIRUS

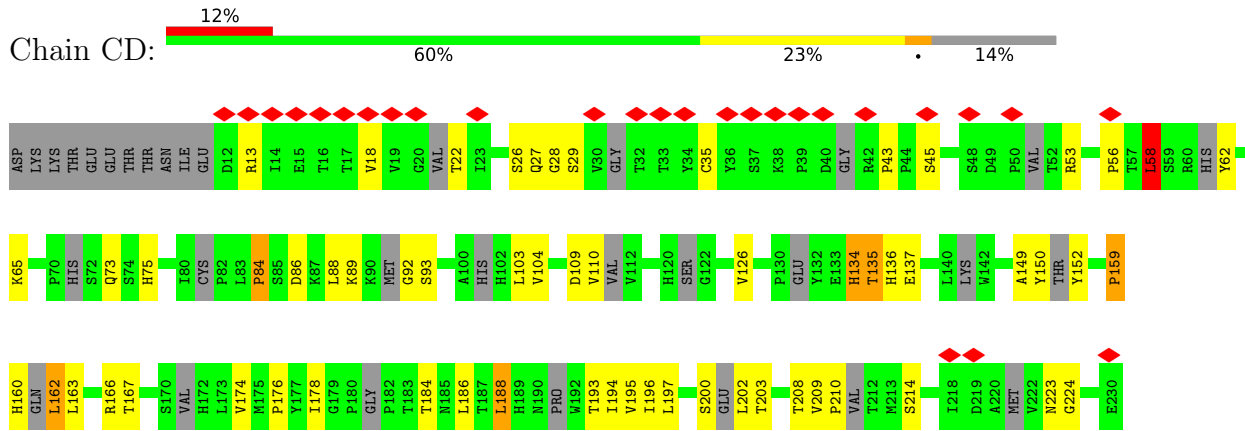

• Molecule 2: EQUINE RHINITIS A VIRUS

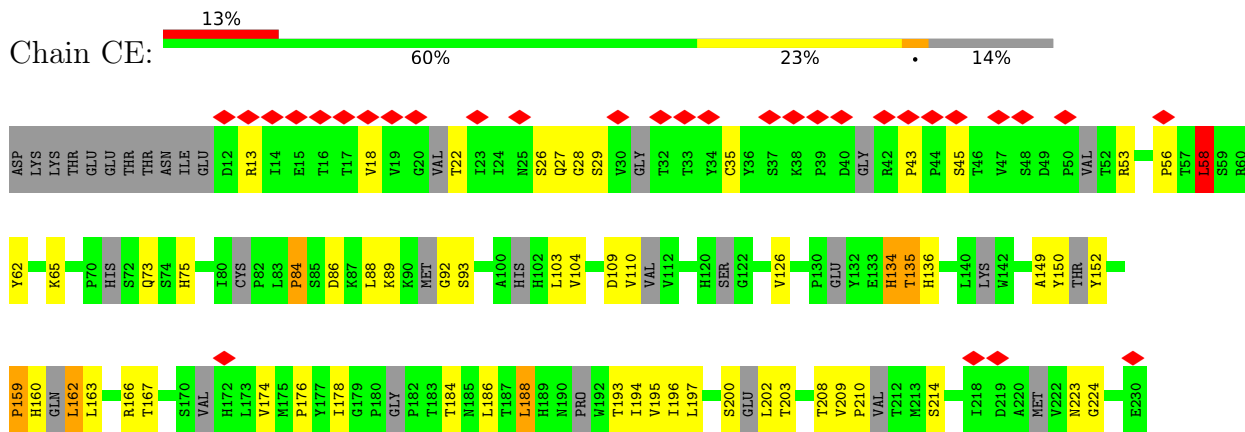

• Molecule 2: EQUINE RHINITIS A VIRUS

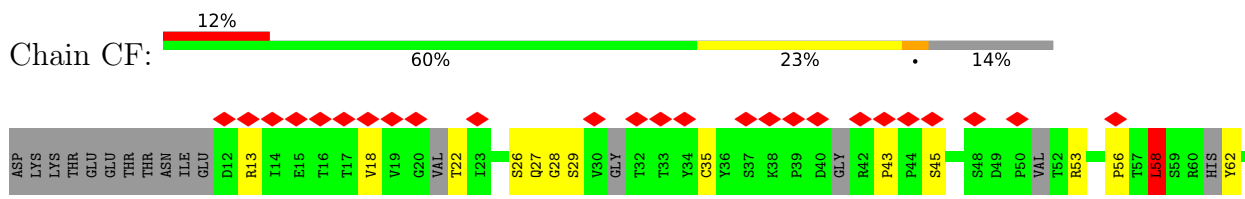



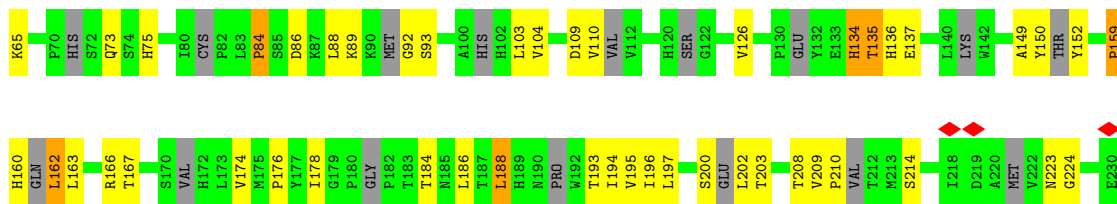

• Molecule 2: EQUINE RHINITIS A VIRUS

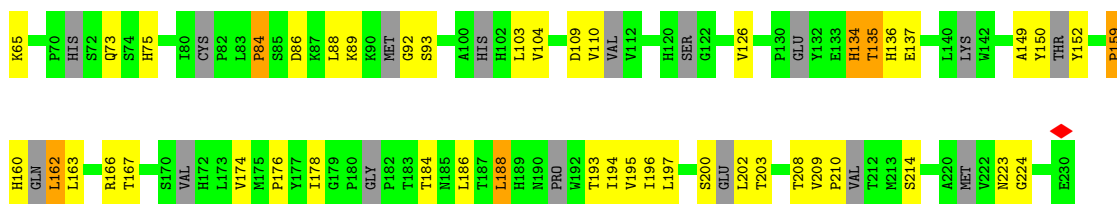
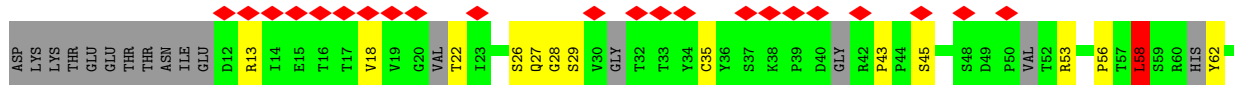

• Molecule 2: EQUINE RHINITIS A VIRUS

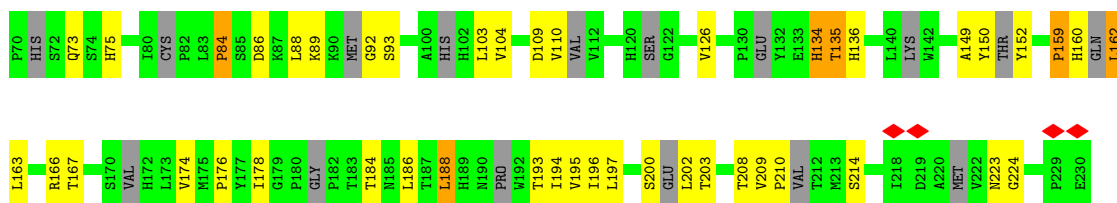
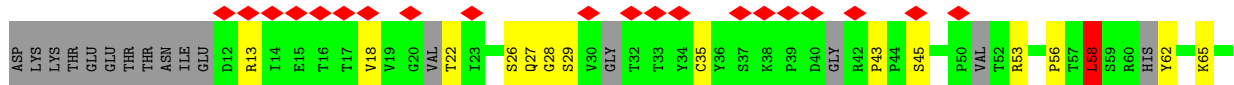

• Molecule 2: EQUINE RHINITIS A VIRUS

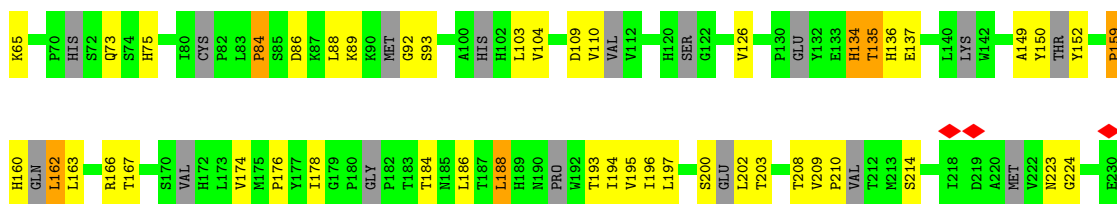
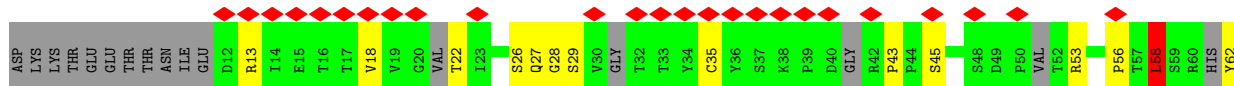

• Molecule 2: EQUINE RHINITIS A VIRUS

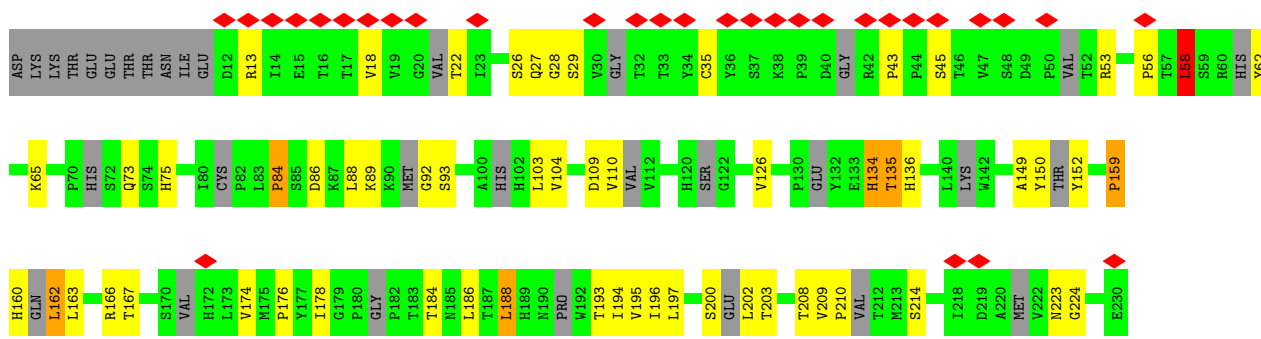

• Molecule 2: EQUINE RHINITIS A VIRUS

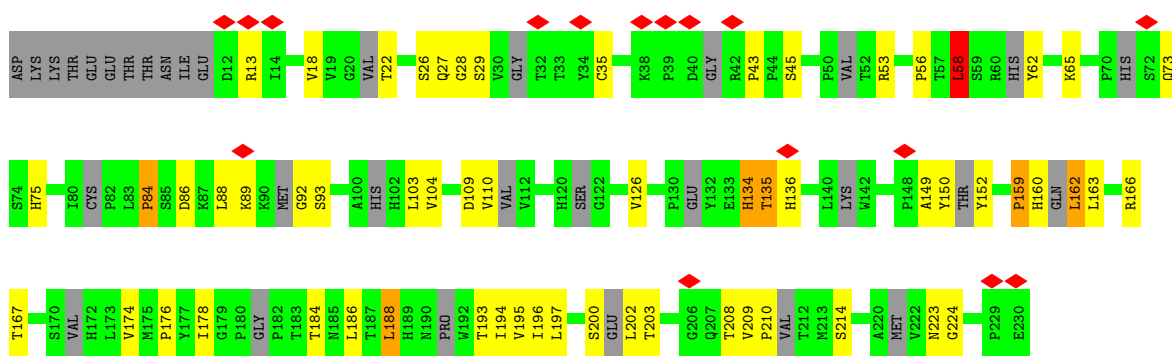

• Molecule 2: EQUINE RHINITIS A VIRUS

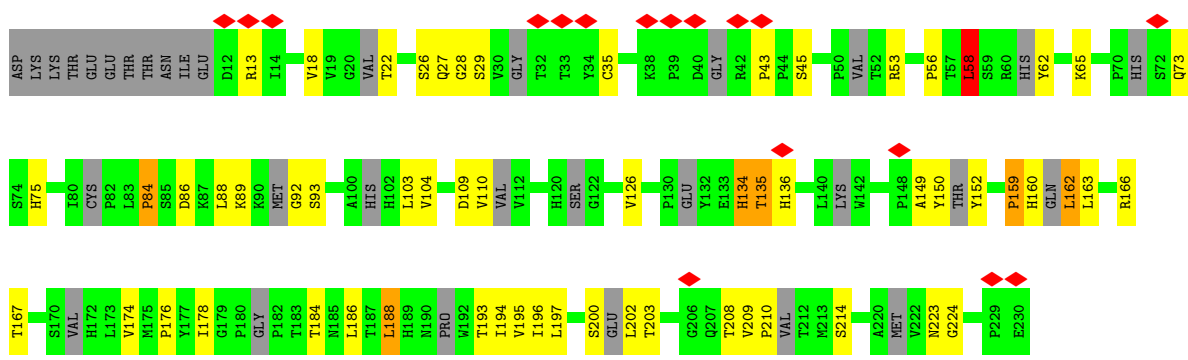

• Molecule 2: EQUINE RHINITIS A VIRUS



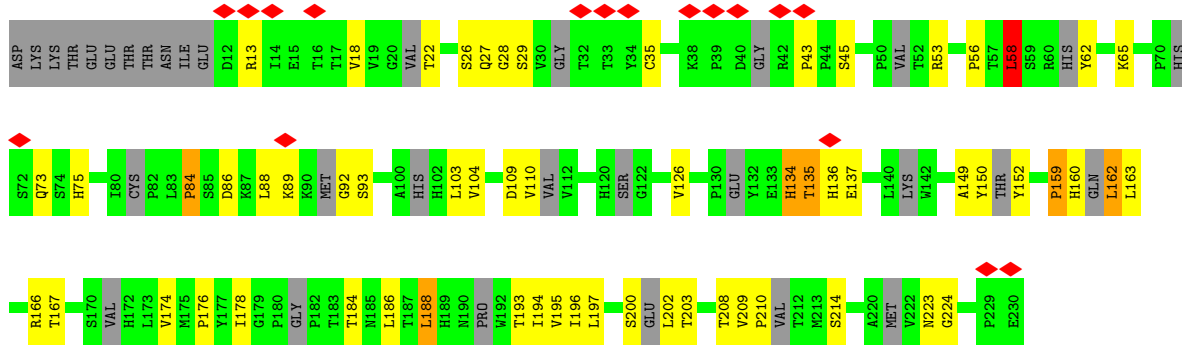

• Molecule 2: EQUINE RHINITIS A VIRUS

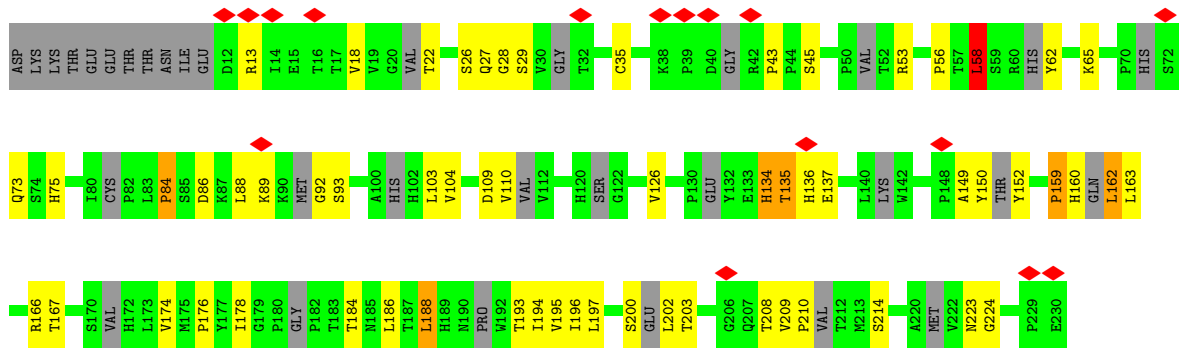

• Molecule 2: EQUINE RHINITIS A VIRUS

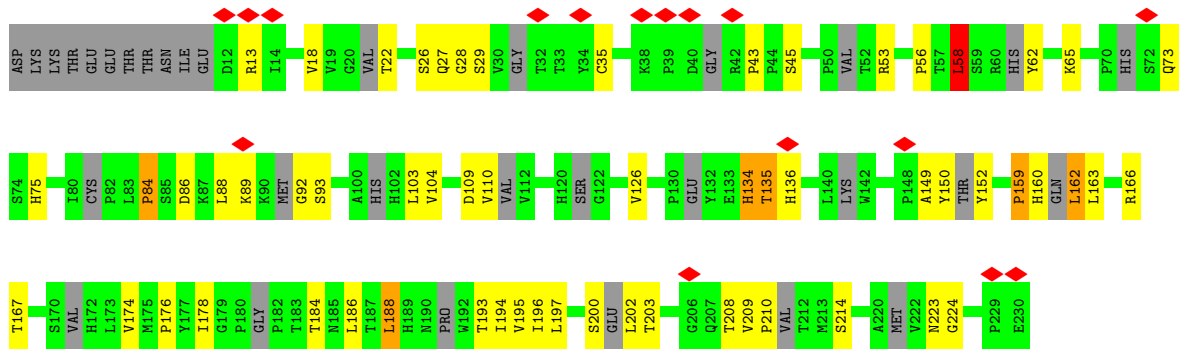

• Molecule 2: EQUINE RHINITIS A VIRUS

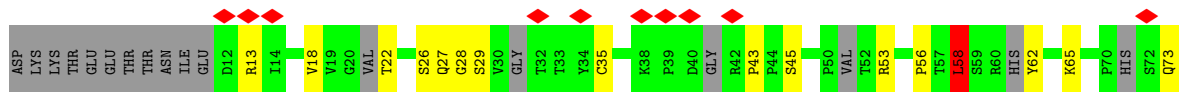

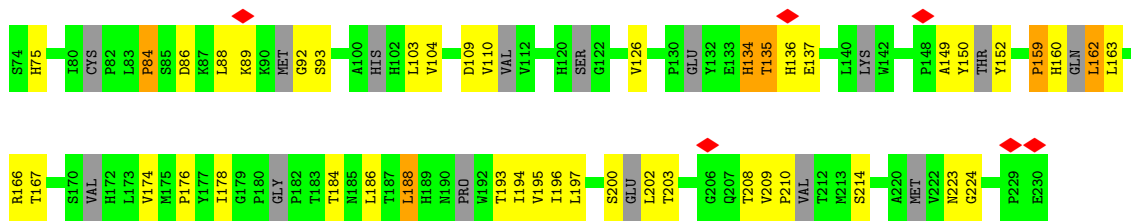

• Molecule 2: EQUINE RHINITIS A VIRUS

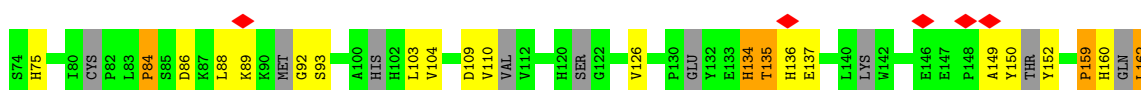
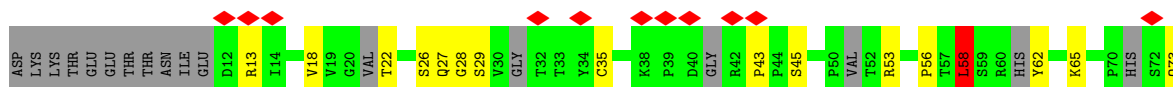

• Molecule 2: EQUINE RHINITIS A VIRUS

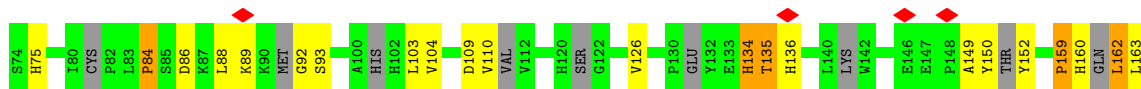
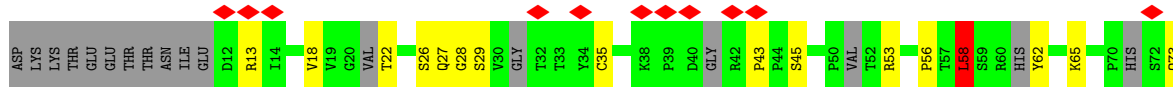

• Molecule 2: EQUINE RHINITIS A VIRUS

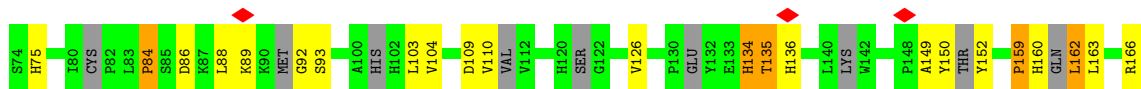
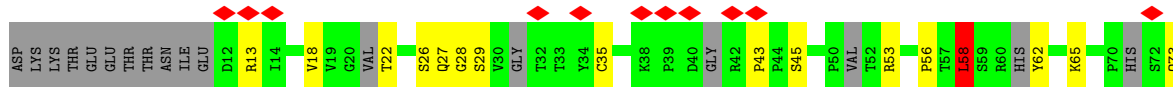



• Molecule 2: EQUINE RHINITIS A VIRUS

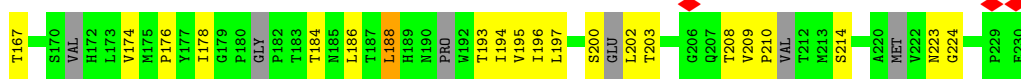
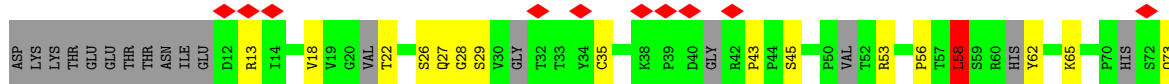

• Molecule 2: EQUINE RHINITIS A VIRUS

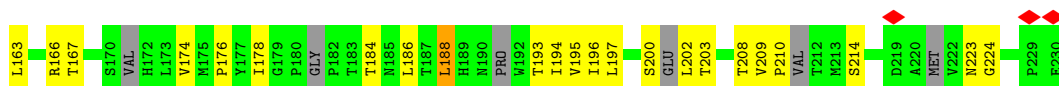
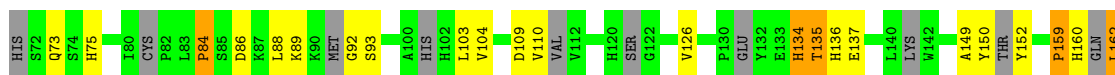
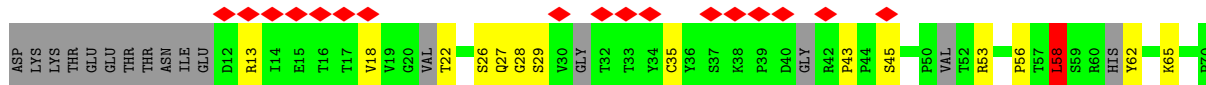

• Molecule 2: EQUINE RHINITIS A VIRUS

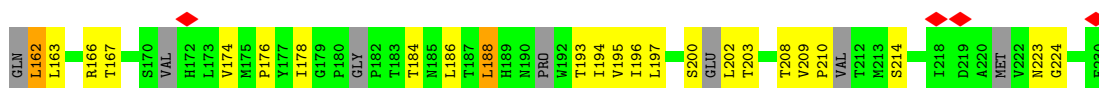
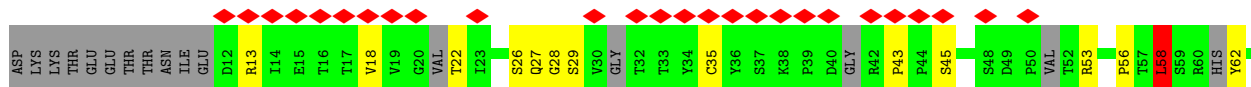

• Molecule 2: EQUINE RHINITIS A VIRUS



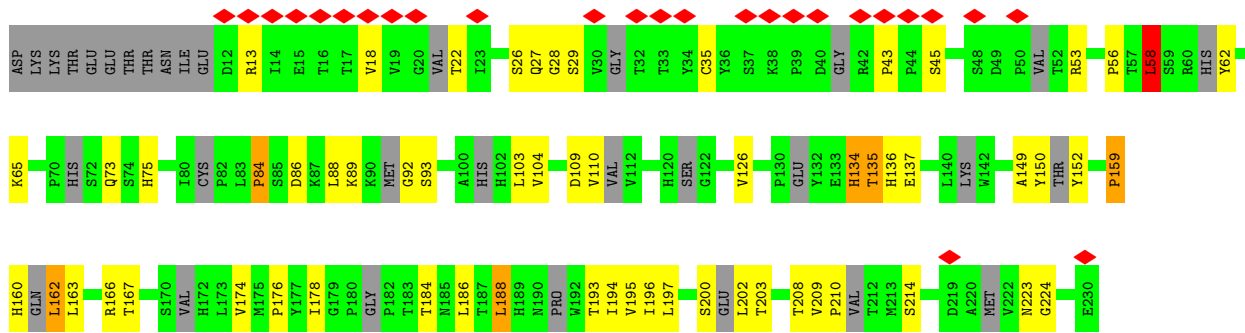

• Molecule 2: EQUINE RHINITIS A VIRUS

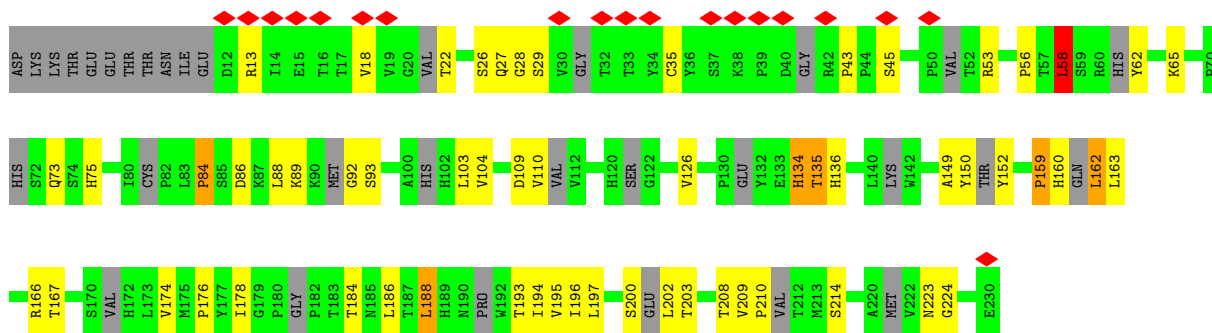

• Molecule 2: EQUINE RHINITIS A VIRUS

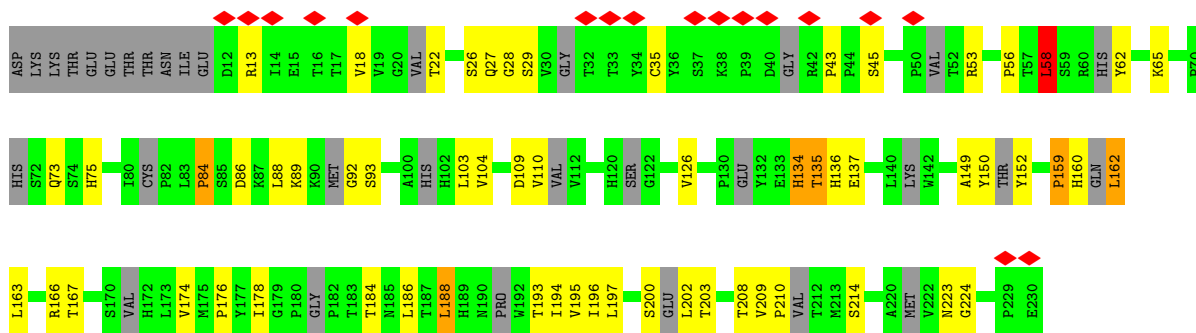

• Molecule 2: EQUINE RHINITIS A VIRUS

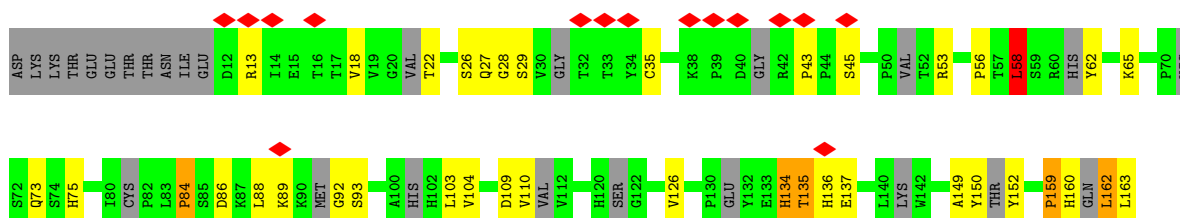

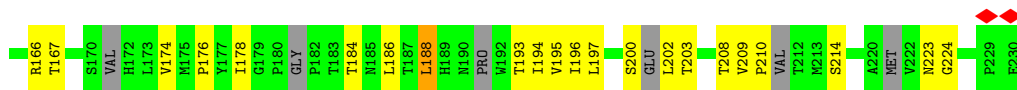

• Molecule 2: EQUINE RHINITIS A VIRUS

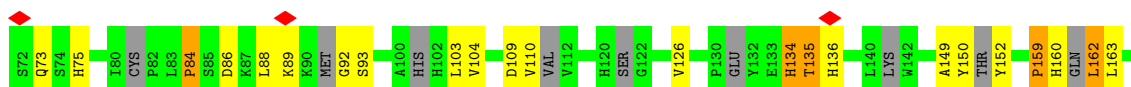
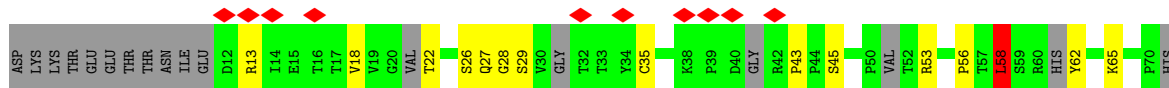

• Molecule 2: EQUINE RHINITIS A VIRUS

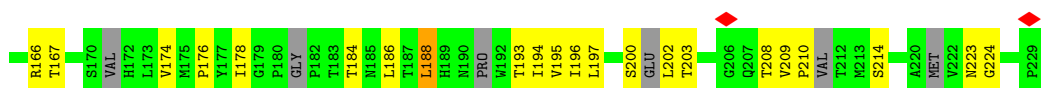
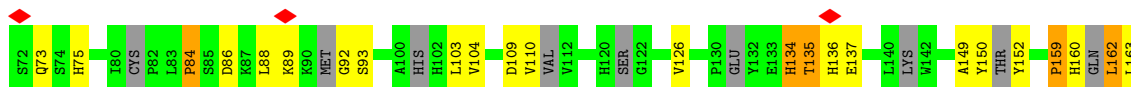
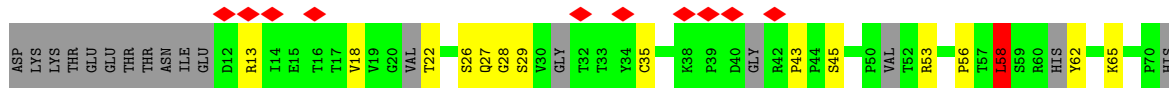

• Molecule 2: EQUINE RHINITIS A VIRUS

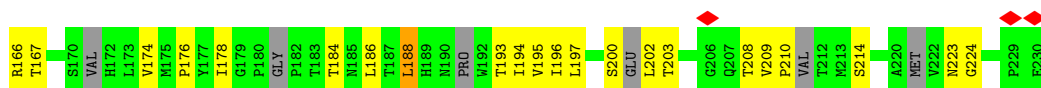
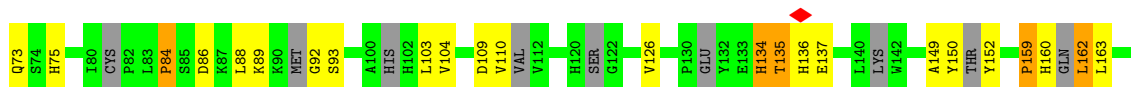
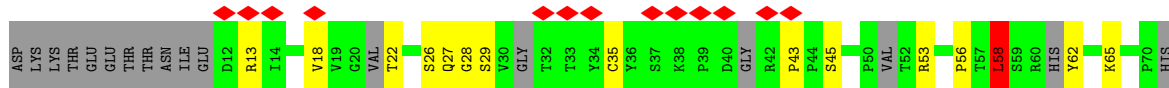

• Molecule 2: EQUINE RHINITIS A VIRUS

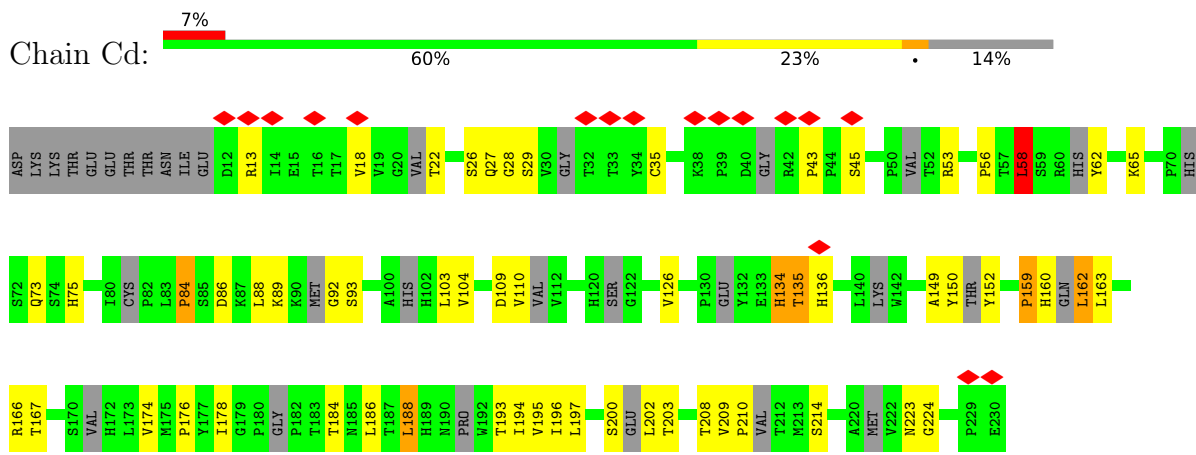

• Molecule 2: EQUINE RHINITIS A VIRUS

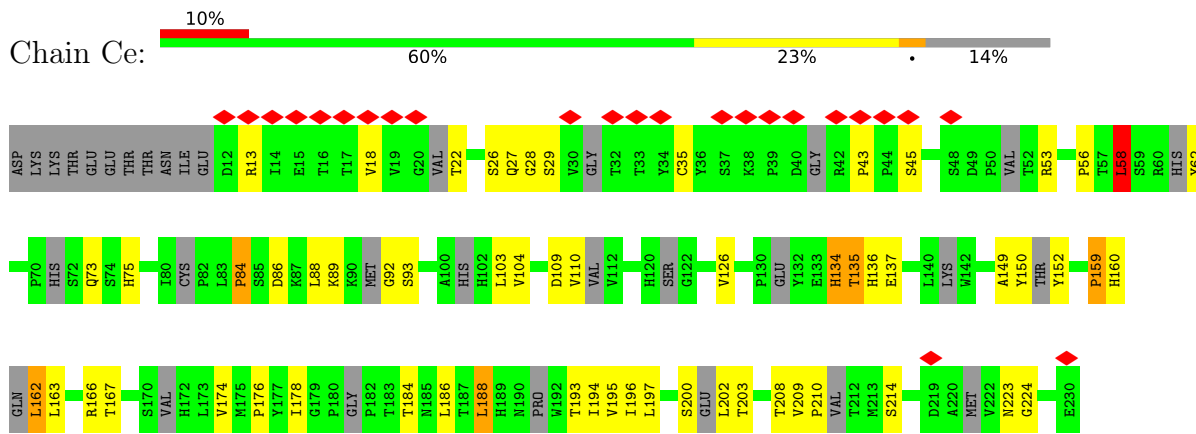

• Molecule 2: EQUINE RHINITIS A VIRUS

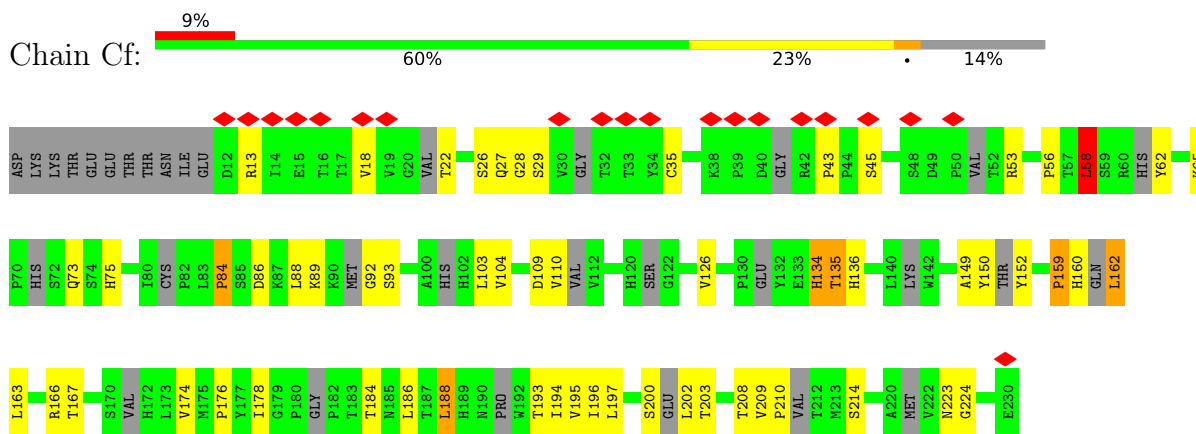

• Molecule 2: EQUINE RHINITIS A VIRUS

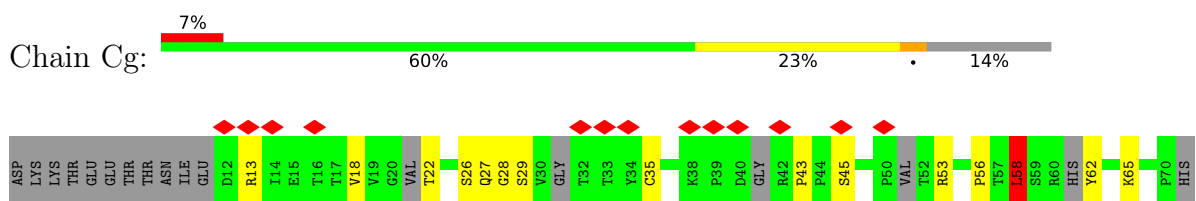



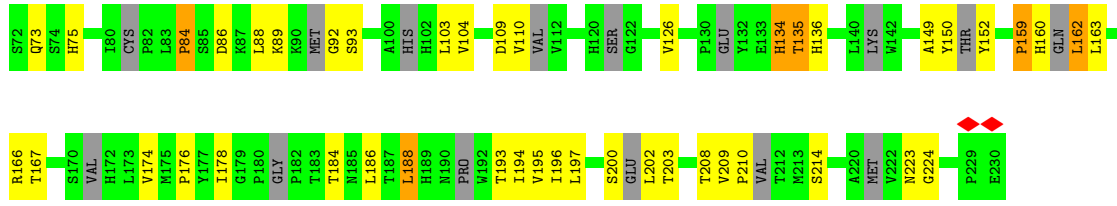

• Molecule 2: EQUINE RHINITIS A VIRUS

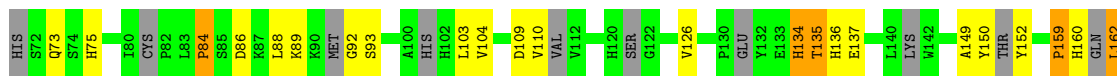
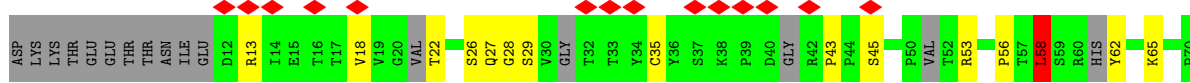

• Molecule 2: EQUINE RHINITIS A VIRUS

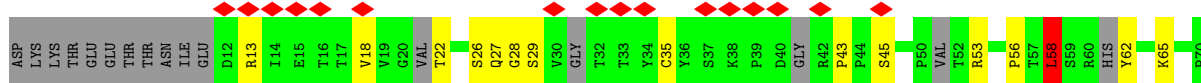

• Molecule 2: EQUINE RHINITIS A VIRUS

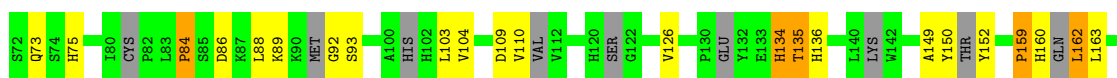
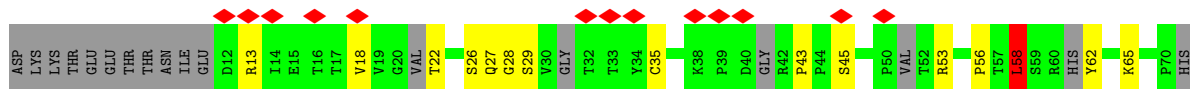

• Molecule 2: EQUINE RHINITIS A VIRUS

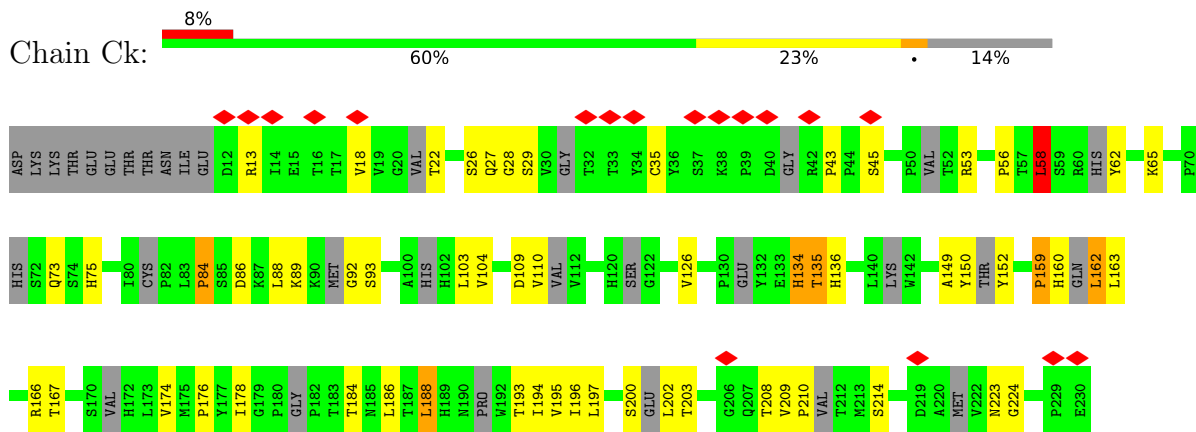

• Molecule 2: EQUINE RHINITIS A VIRUS

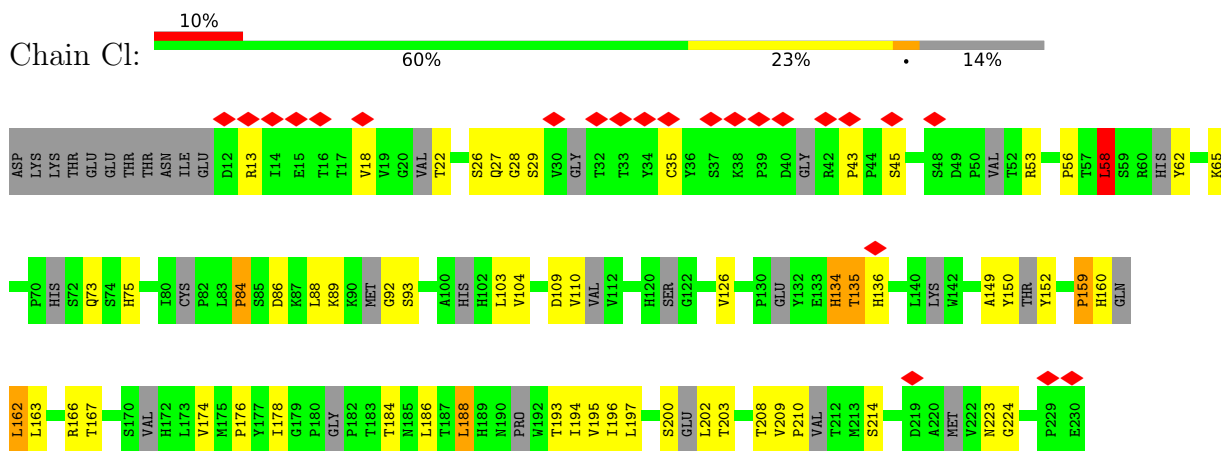

• Molecule 2: EQUINE RHINITIS A VIRUS

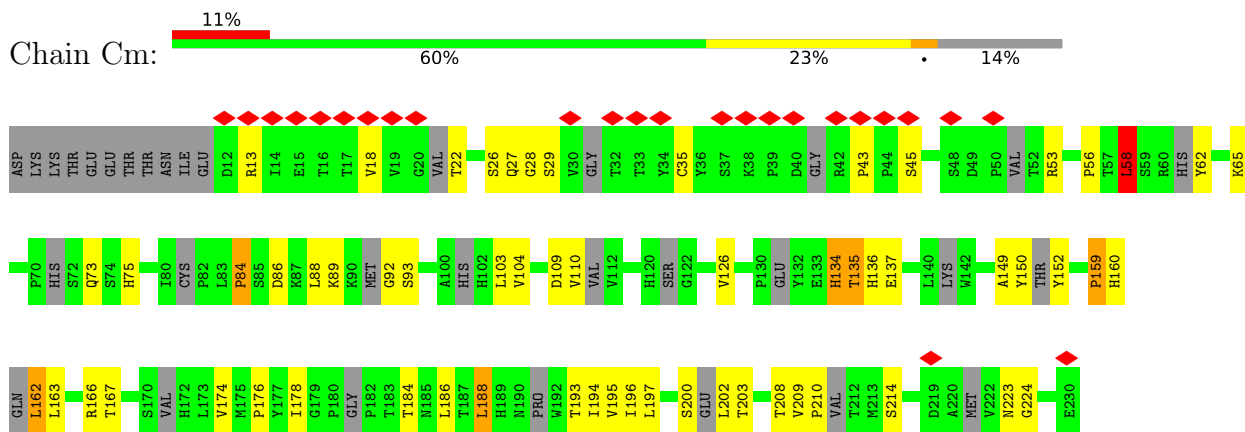

• Molecule 2: EQUINE RHINITIS A VIRUS

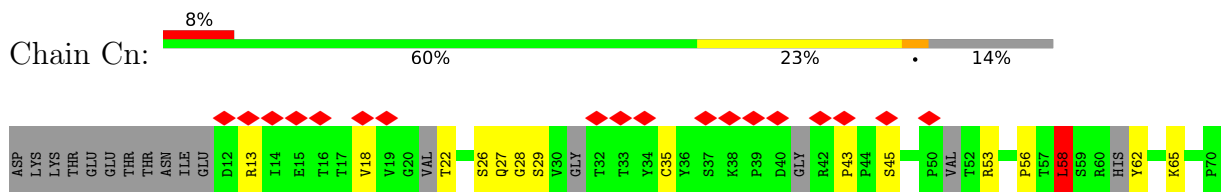

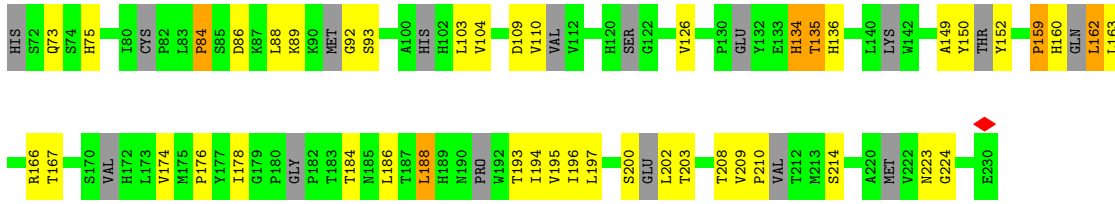

• Molecule 2: EQUINE RHINITIS A VIRUS

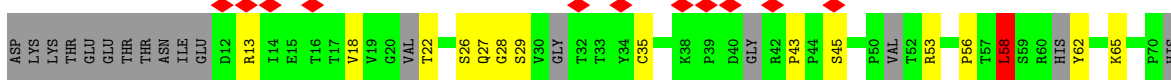

• Molecule 2: EQUINE RHINITIS A VIRUS

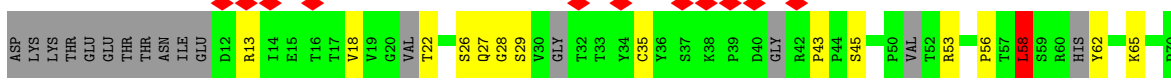

• Molecule 2: EQUINE RHINITIS A VIRUS

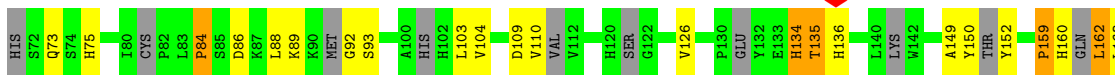
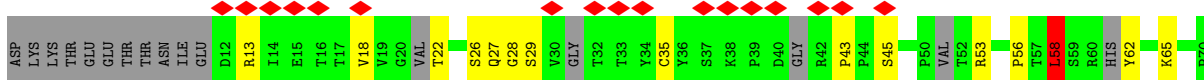

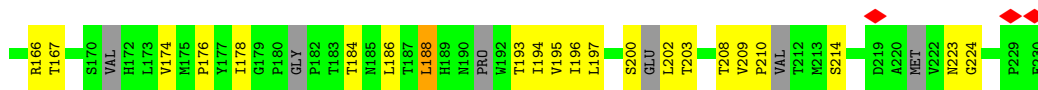

• Molecule 2: EQUINE RHINITIS A VIRUS

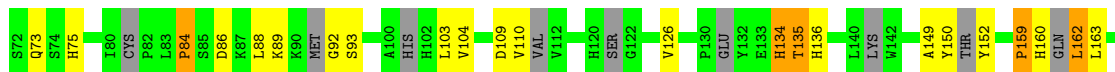

• Molecule 2: EQUINE RHINITIS A VIRUS

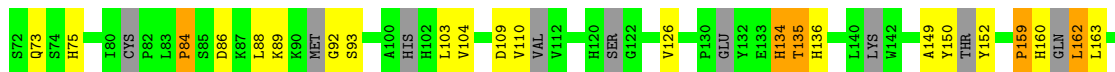
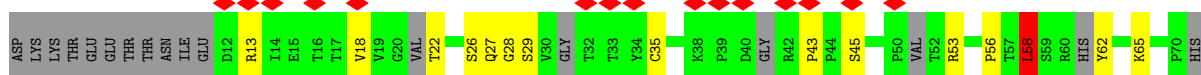

• Molecule 2: EQUINE RHINITIS A VIRUS

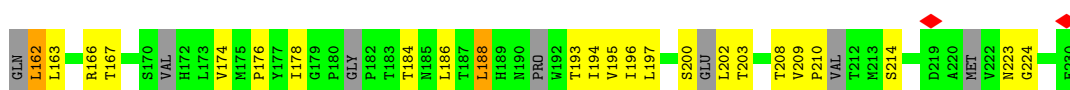
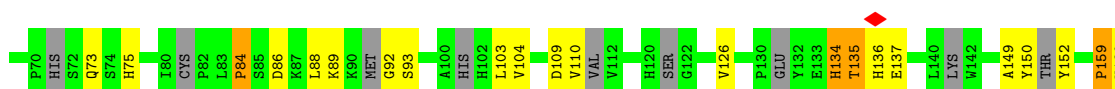
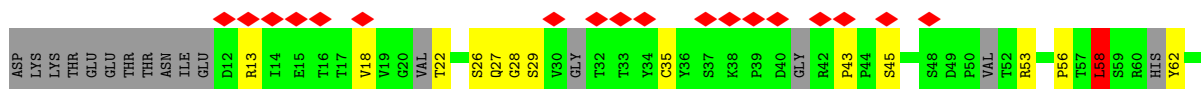

• Molecule 2: EQUINE RHINITIS A VIRUS



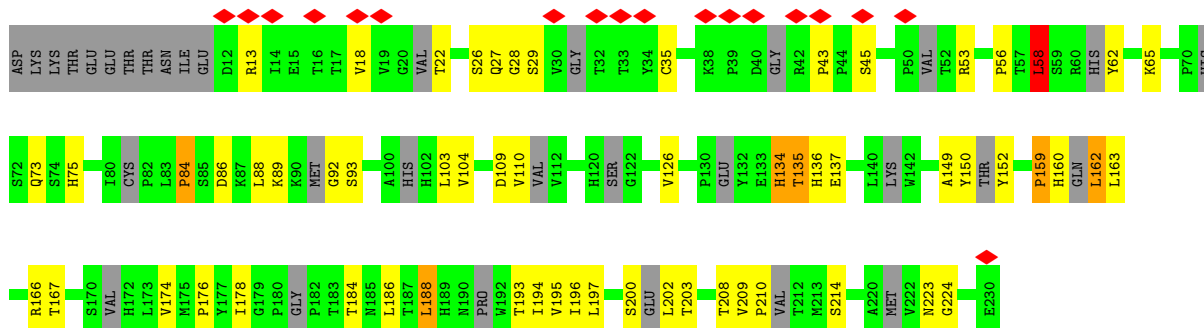

• Molecule 2: EQUINE RHINITIS A VIRUS

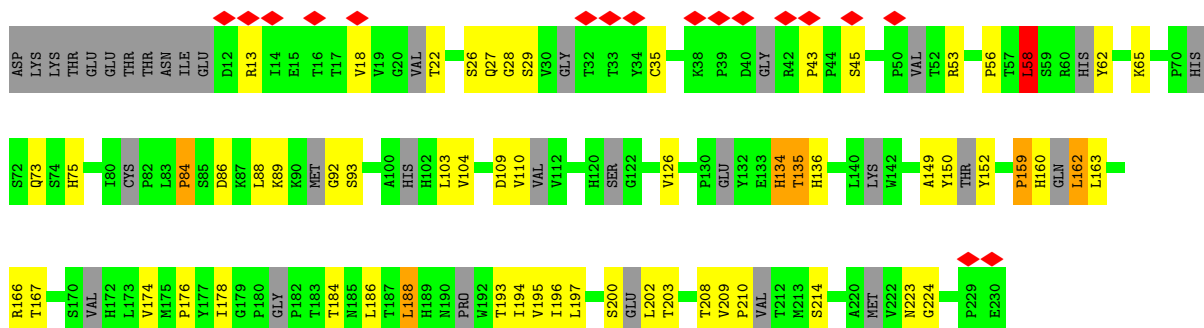

• Molecule 2: EQUINE RHINITIS A VIRUS

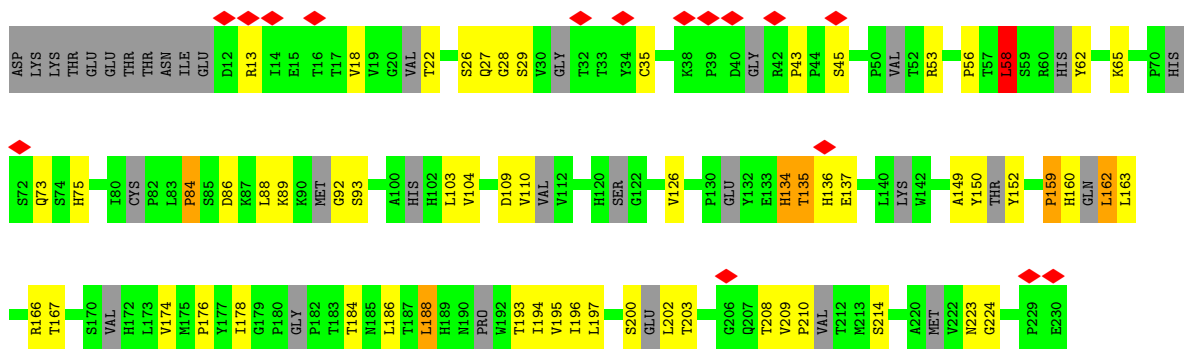

• Molecule 2: EQUINE RHINITIS A VIRUS

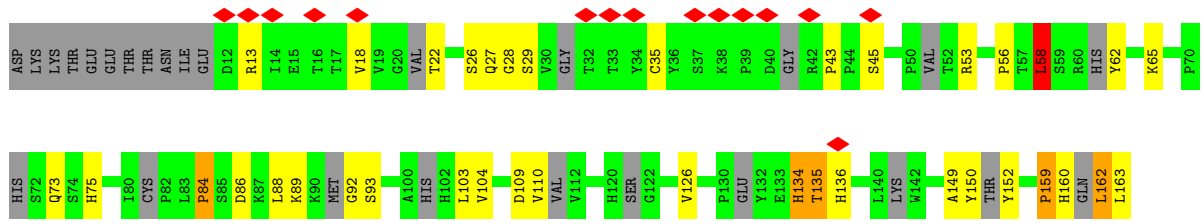

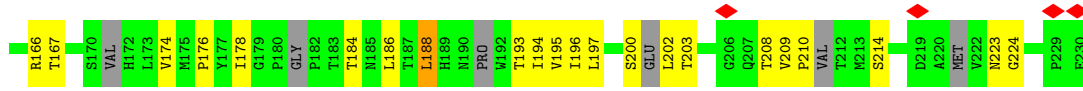

• Molecule 3: P1

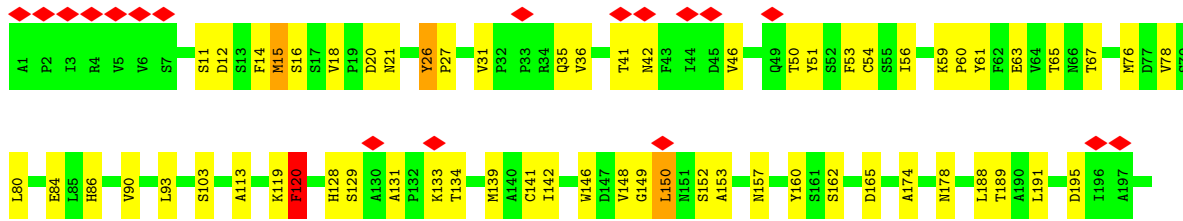
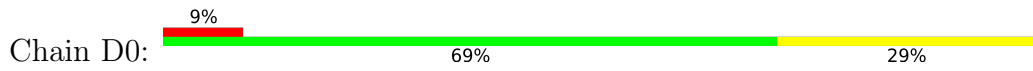

• Molecule 3: P1

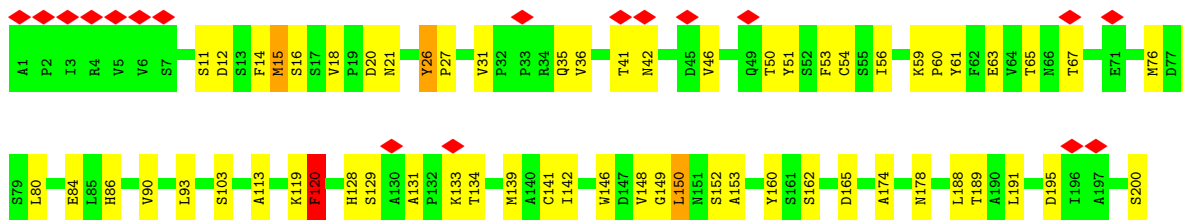
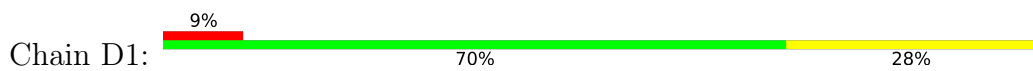

• Molecule 3: P1

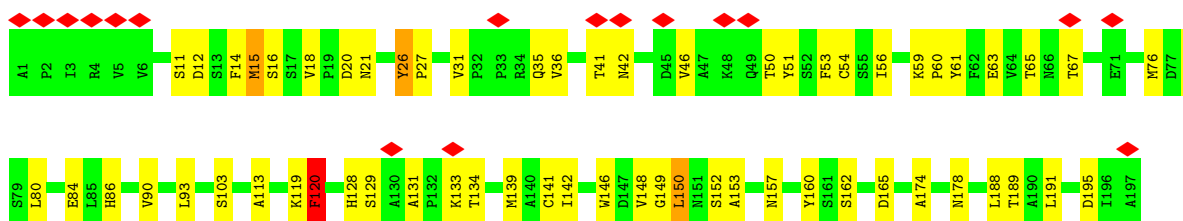
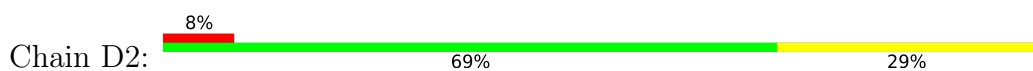

• Molecule 3: P1

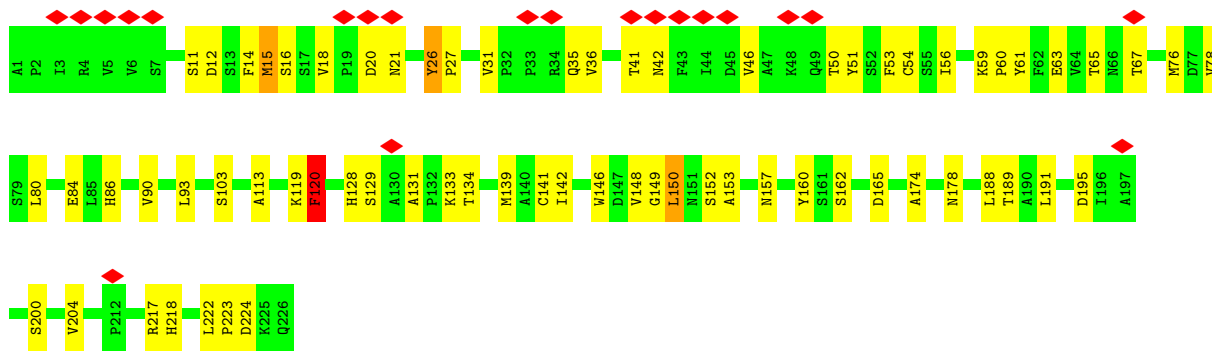
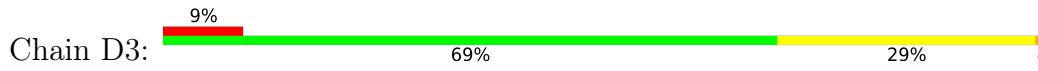

• Molecule 3: P1

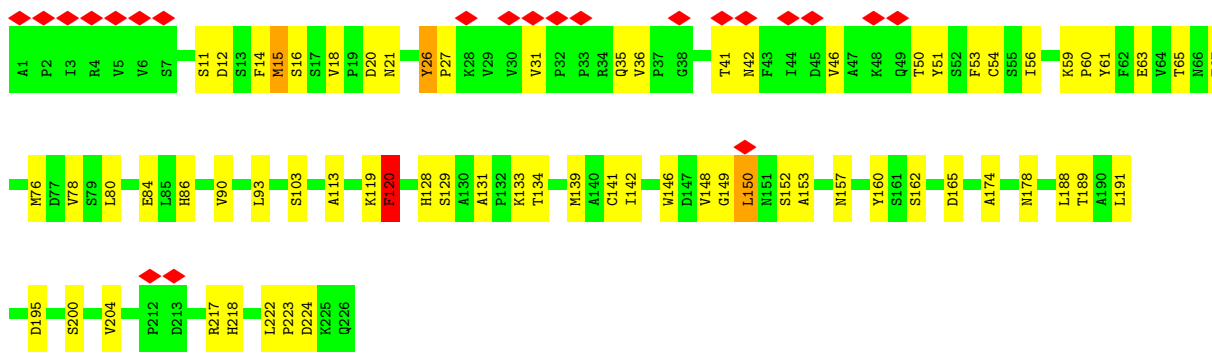
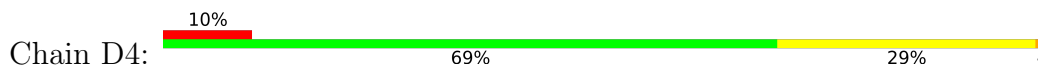

• Molecule 3: P1

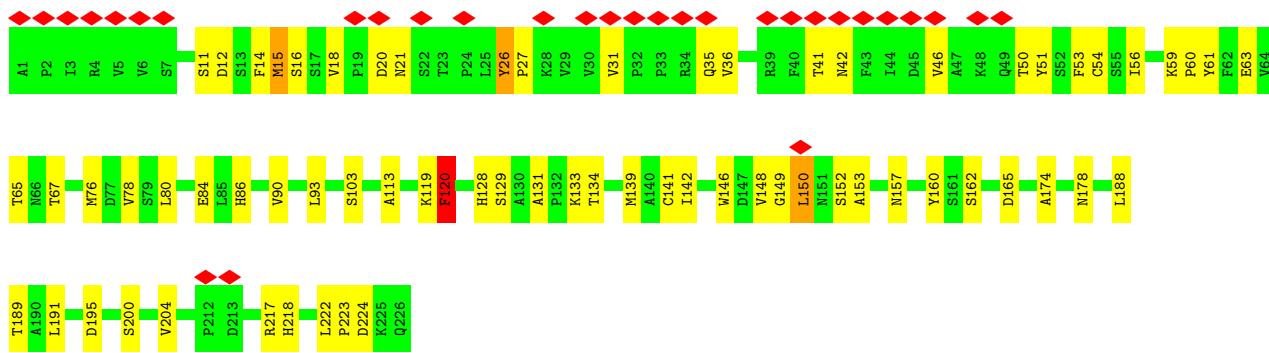
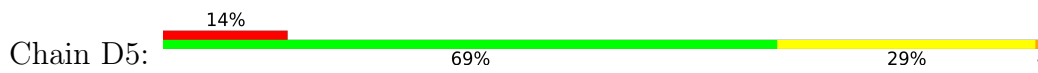

• Molecule 3: P1

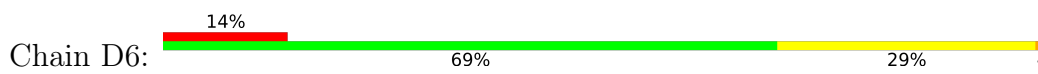

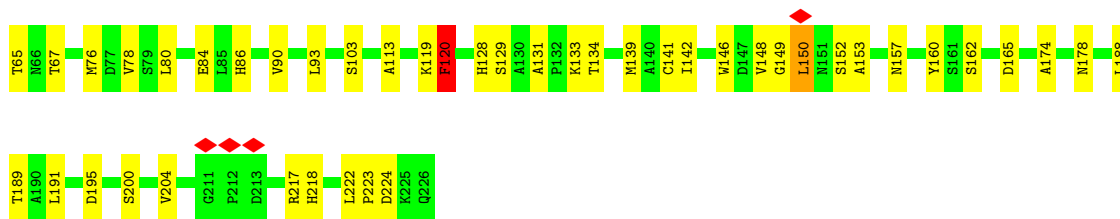

• Molecule 3: P1



• Molecule 3: P1



• Molecule 3: P1

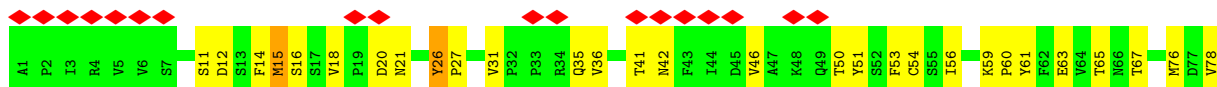
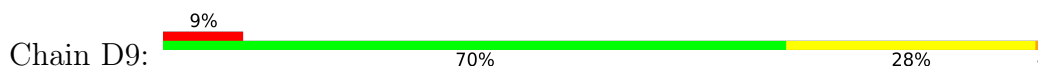



• Molecule 3: P1

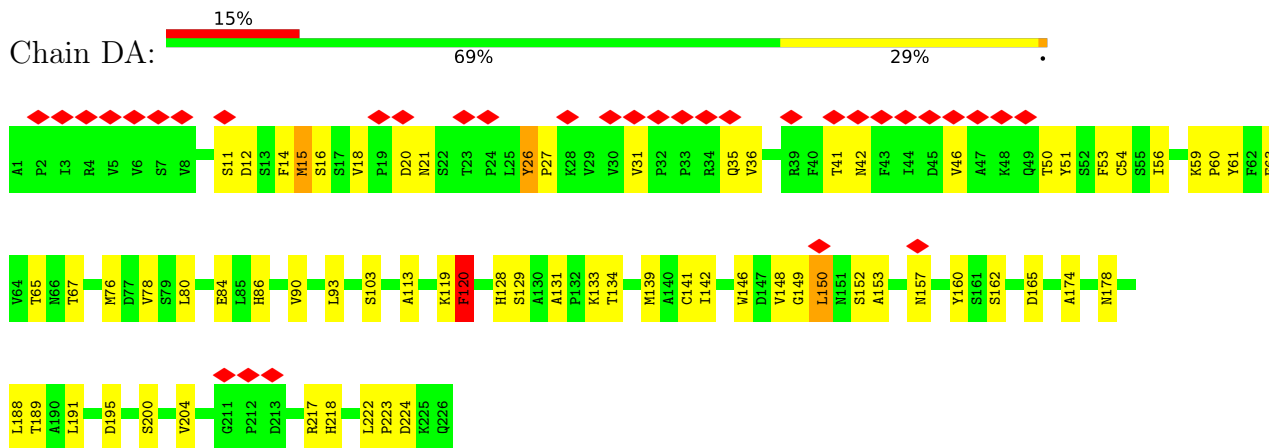

• Molecule 3: P1

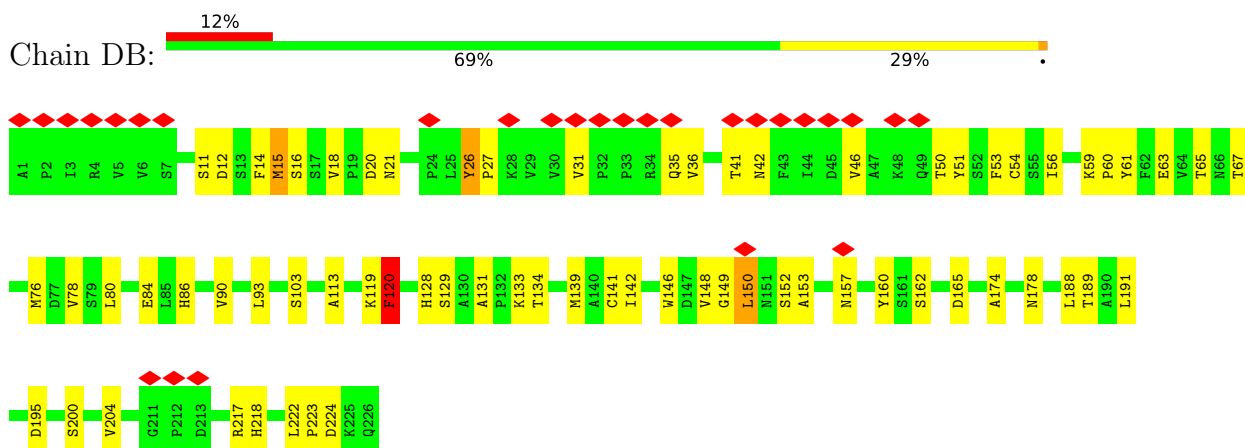

• Molecule 3: P1

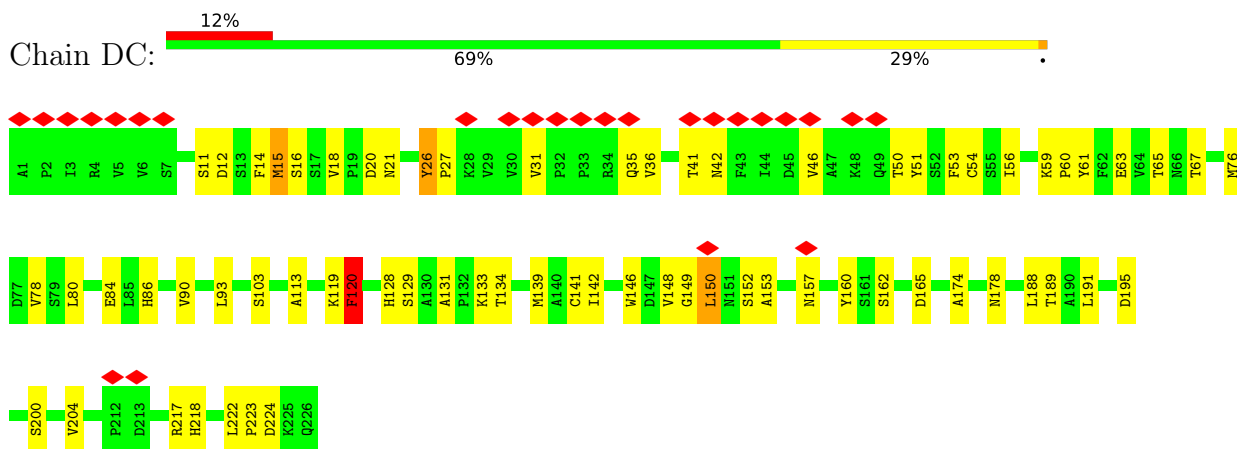

• Molecule 3: P1

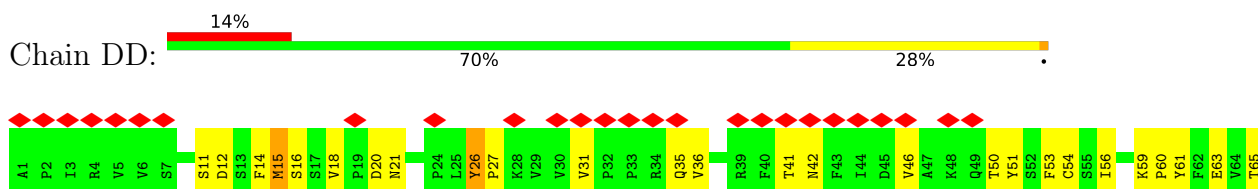

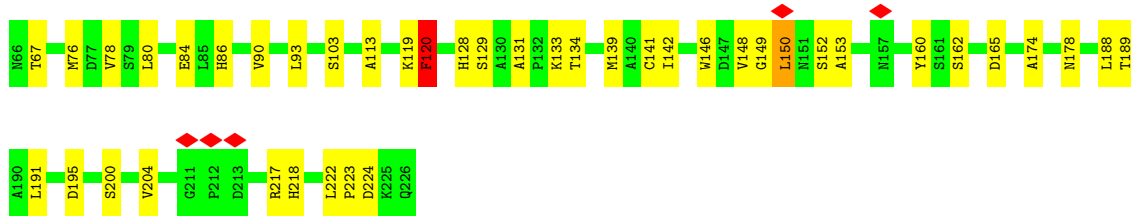

• Molecule 3: P1

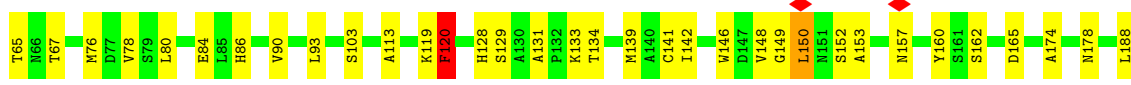
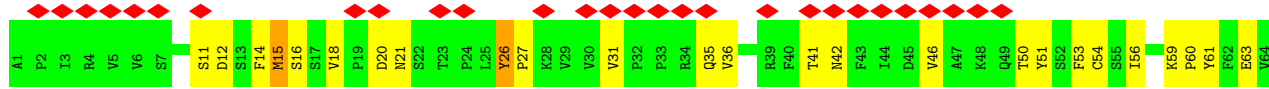

• Molecule 3: P1

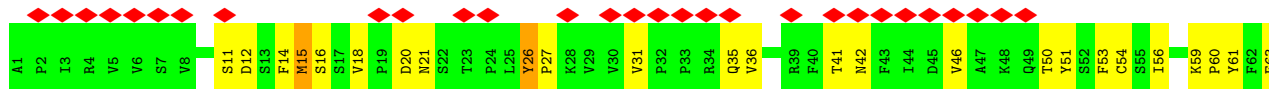
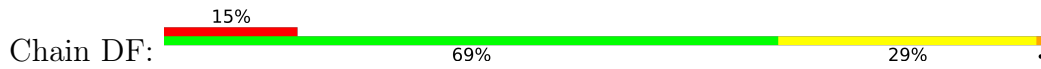

• Molecule 3: P1

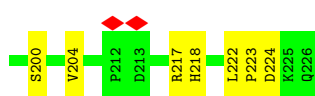
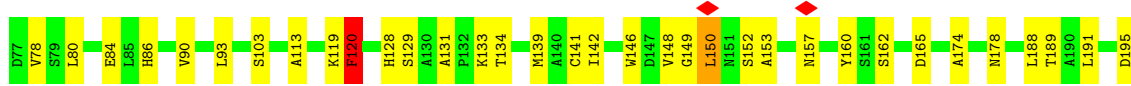
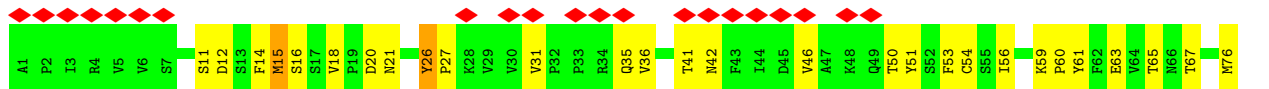
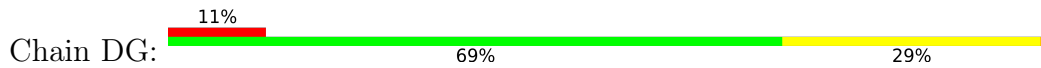

• Molecule 3: P1

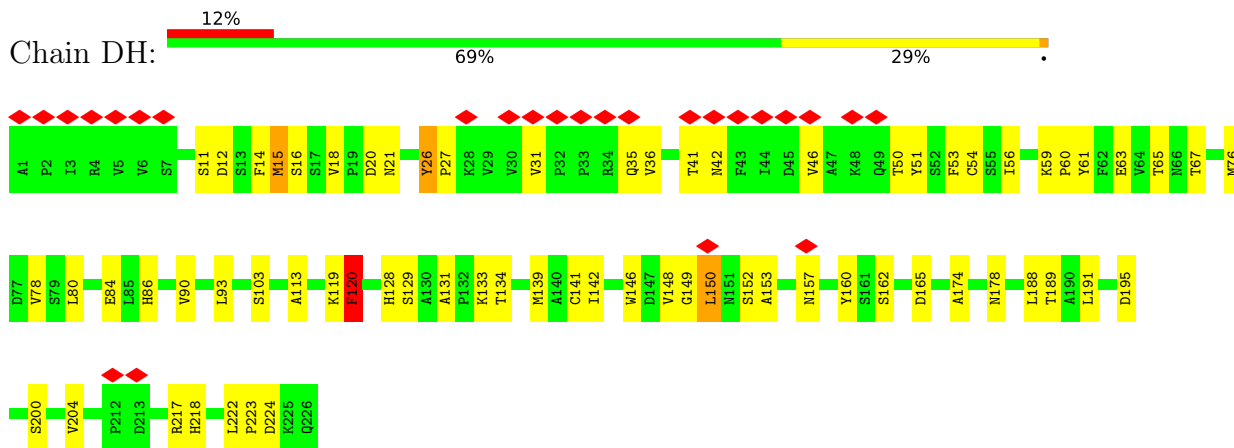

• Molecule 3: P1

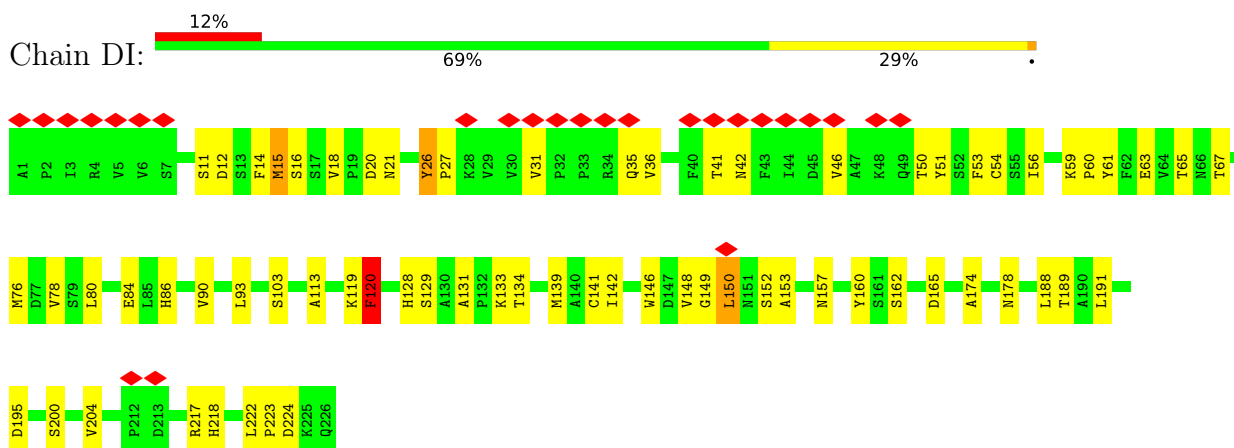

• Molecule 3: P1

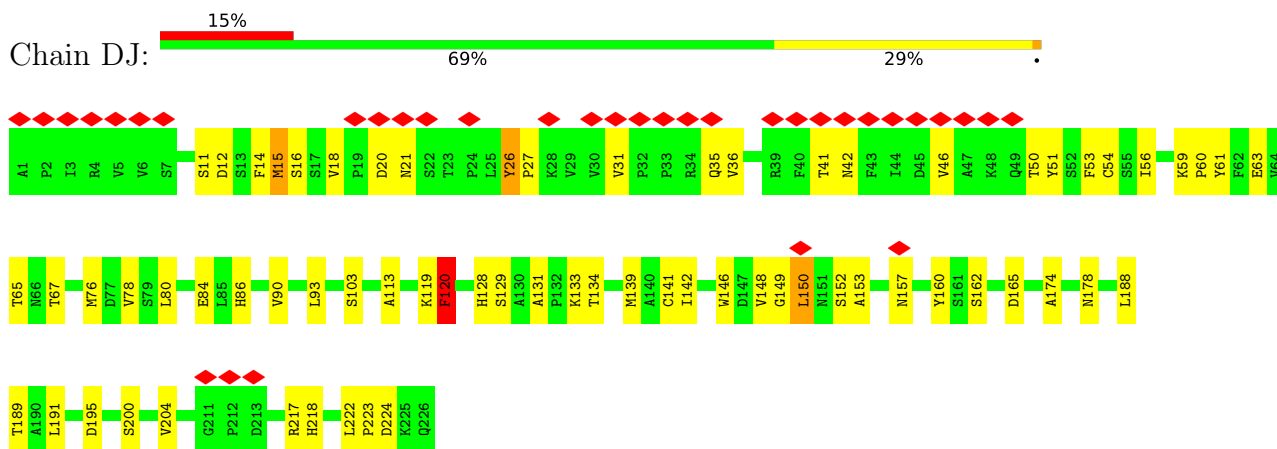

• Molecule 3: P1

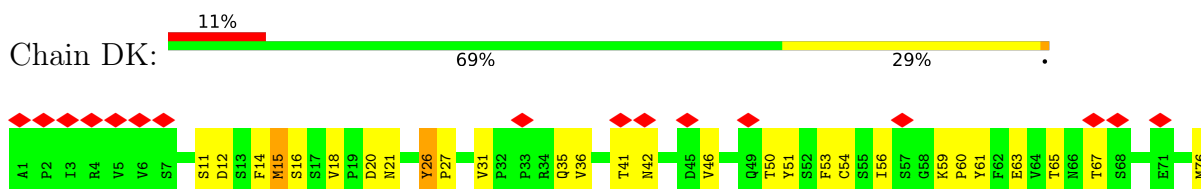

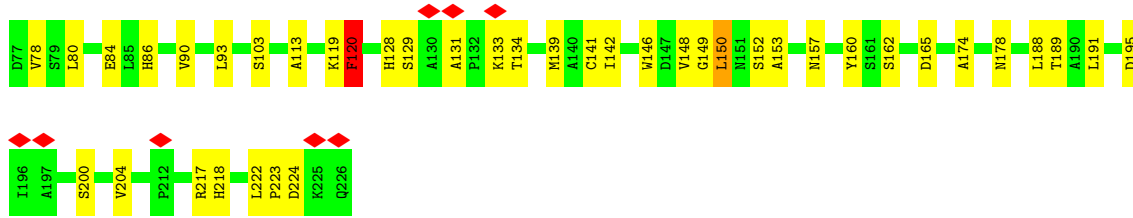

• Molecule 3: P1

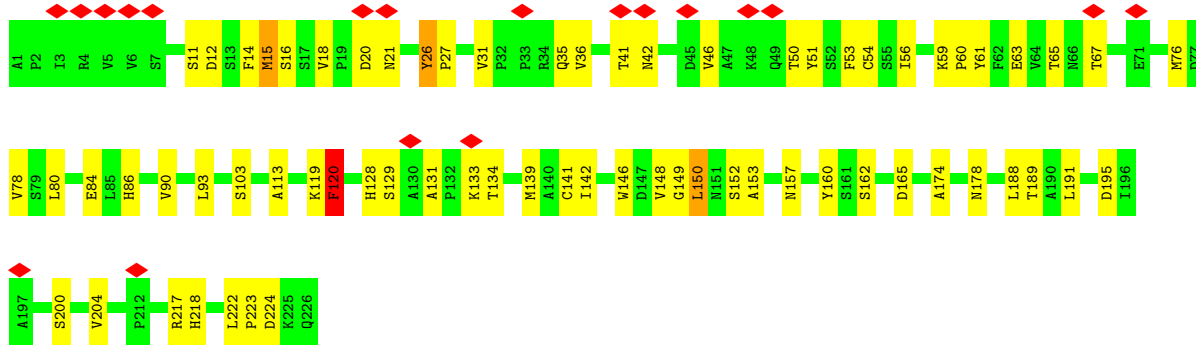
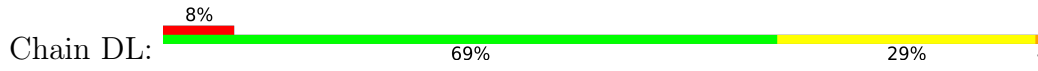

• Molecule 3: P1

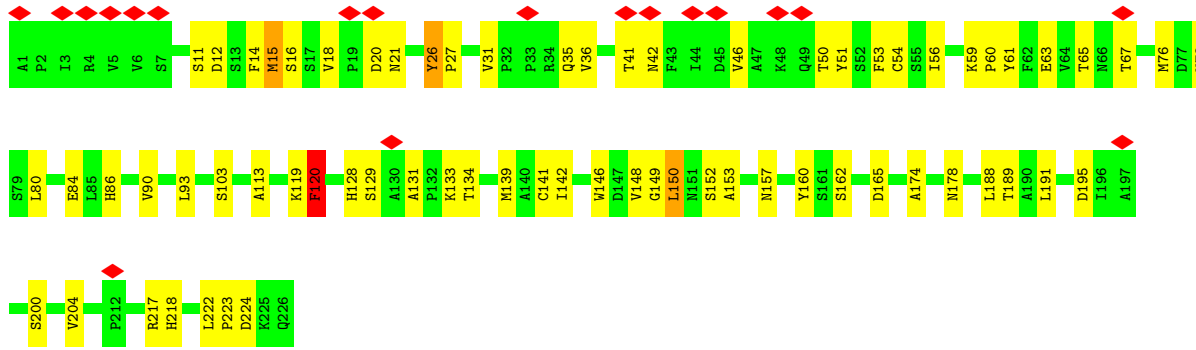
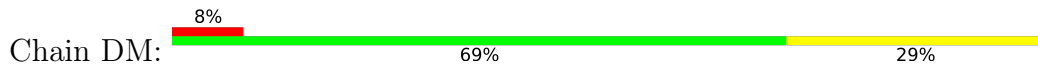

• Molecule 3: P1

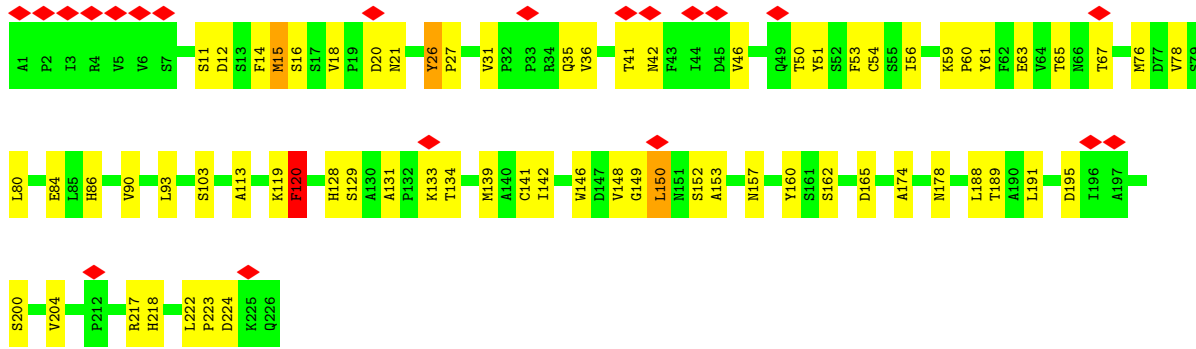

• Molecule 3: P1

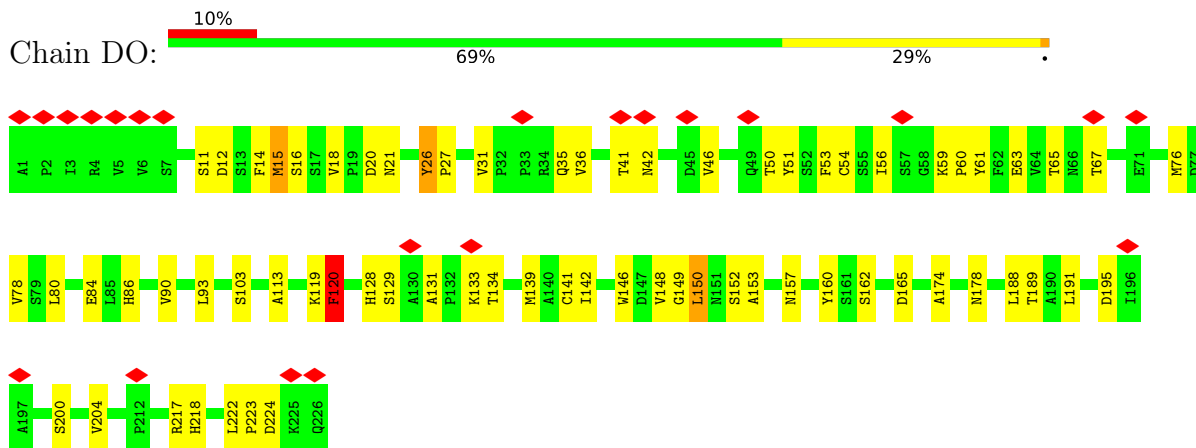

• Molecule 3: P1

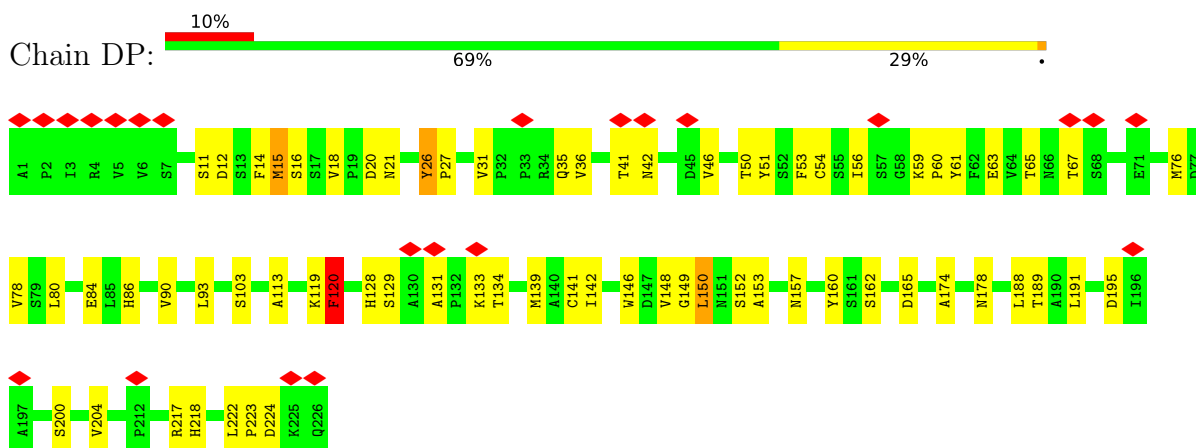

• Molecule 3: P1

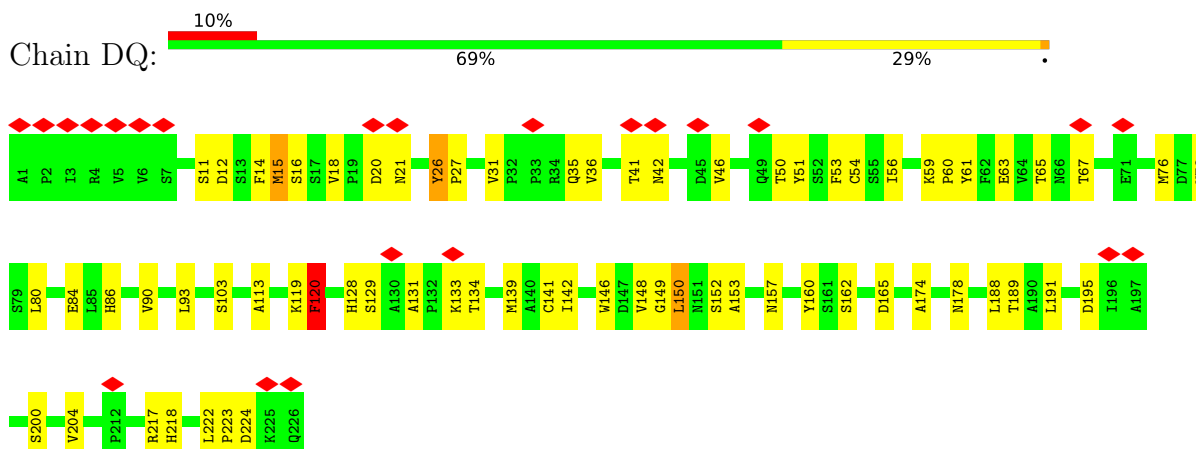

• Molecule 3: P1



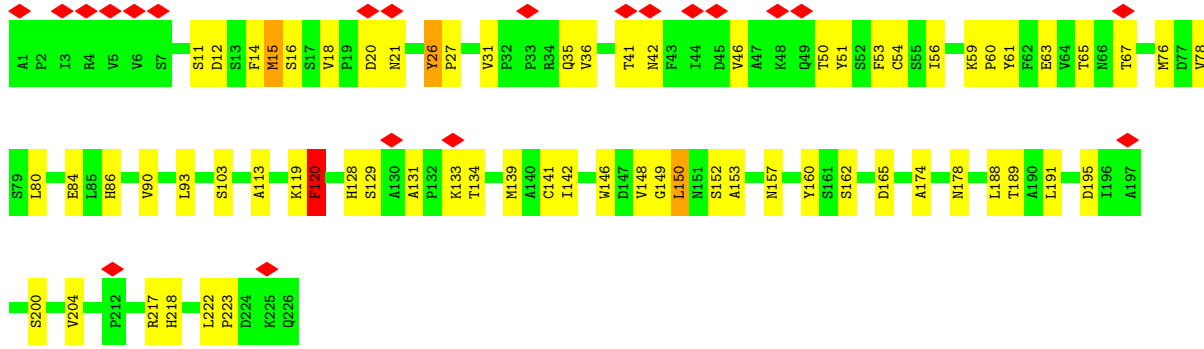

• Molecule 3: P1

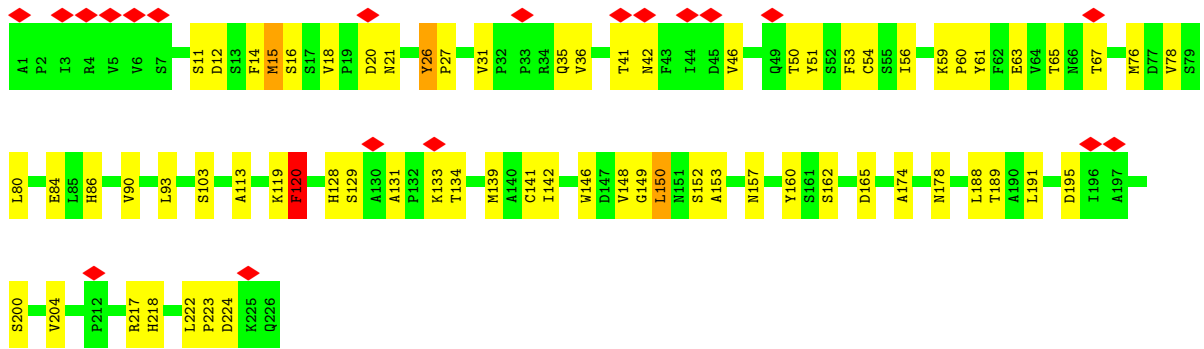

• Molecule 3: P1

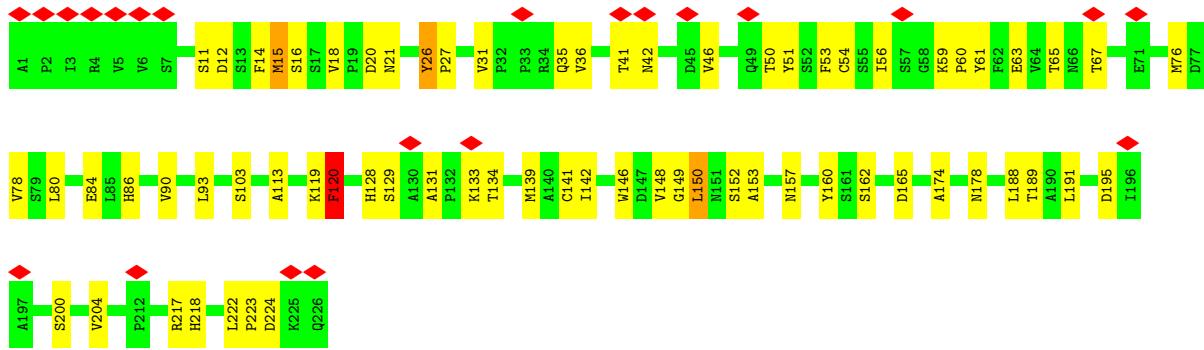
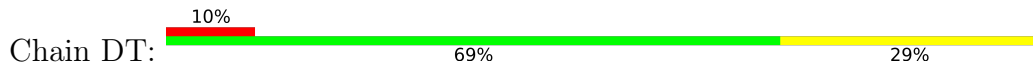

• Molecule 3: P1

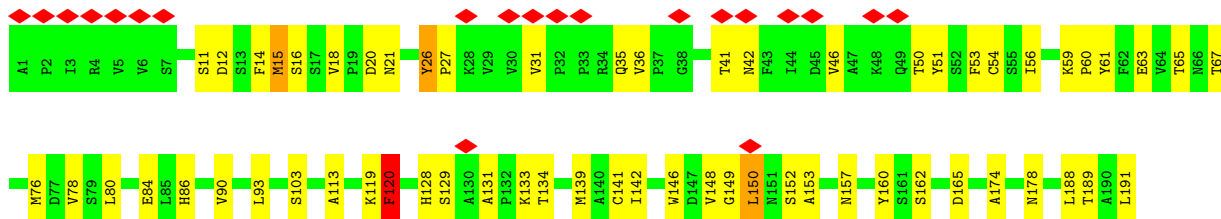
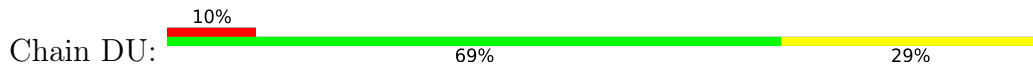

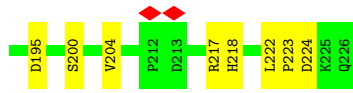

• Molecule 3: P1

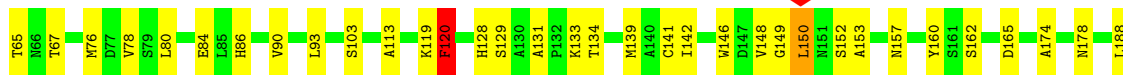
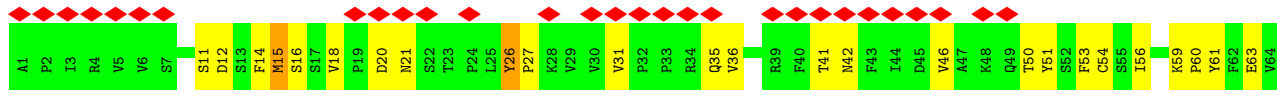
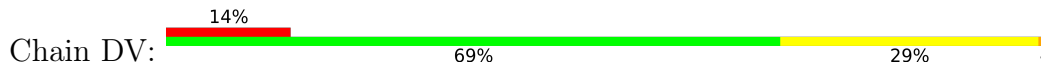

• Molecule 3: P1

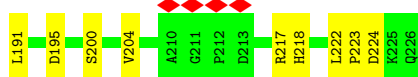
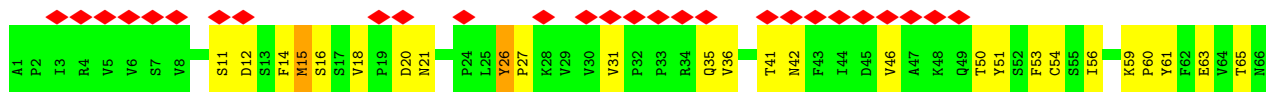
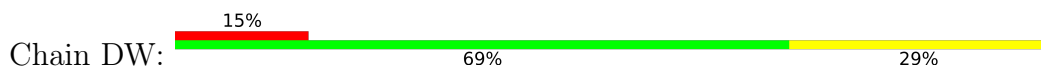

• Molecule 3: P1

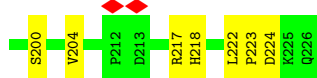
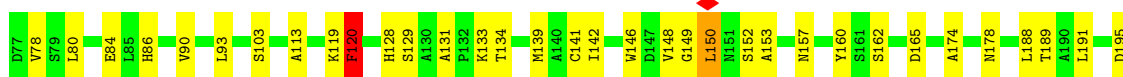
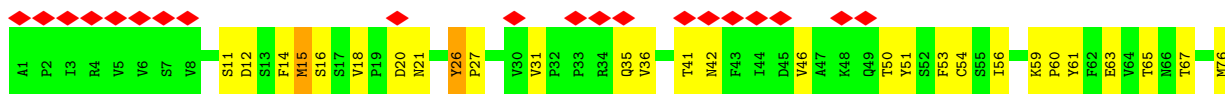
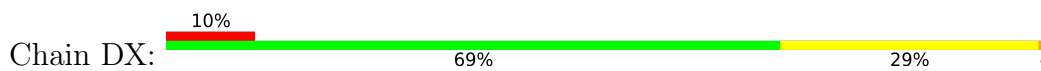

• Molecule 3: P1

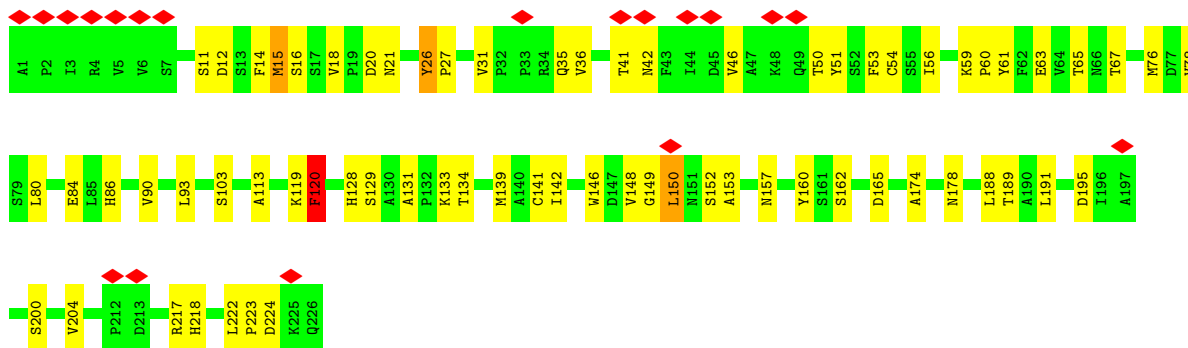
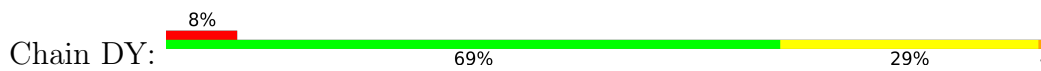

• Molecule 3: P1

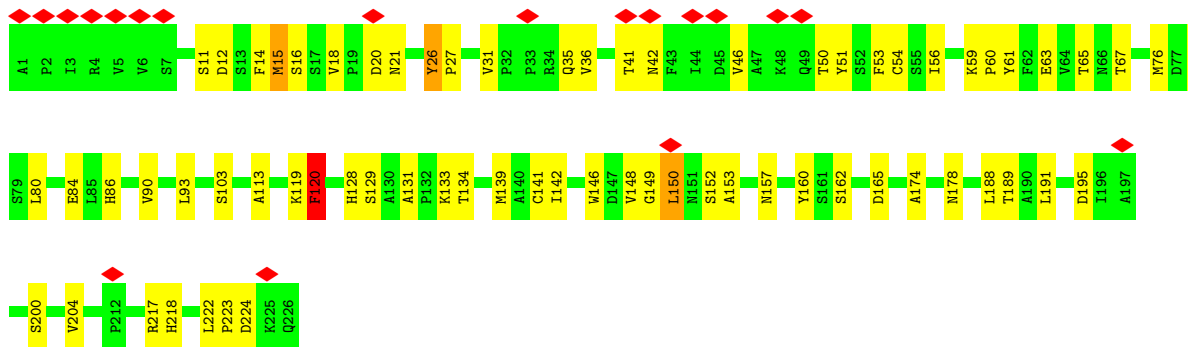

• Molecule 3: P1

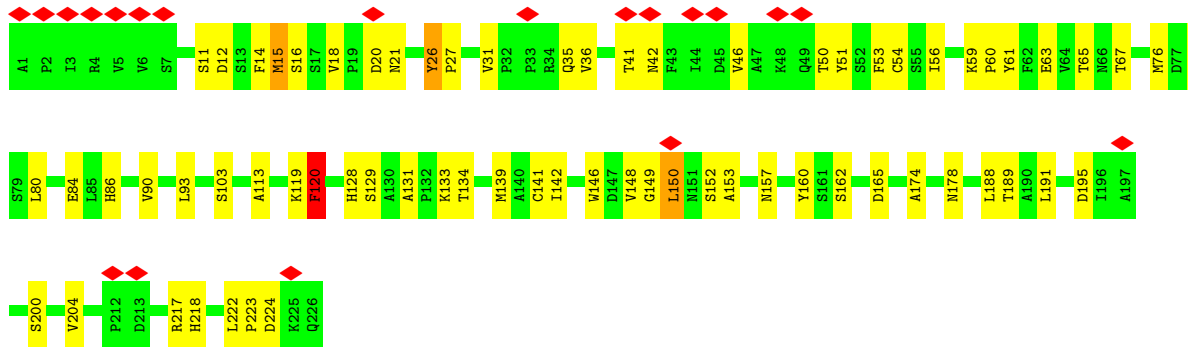
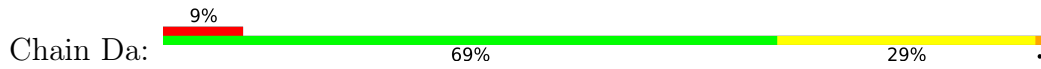

• Molecule 3: P1

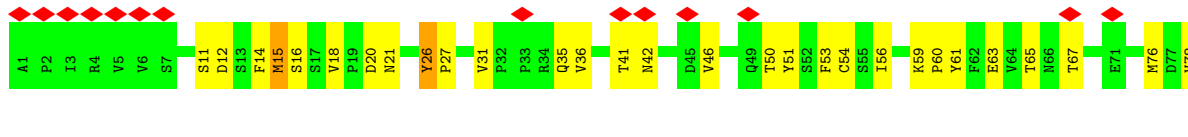





• Molecule 3: P1

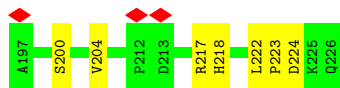
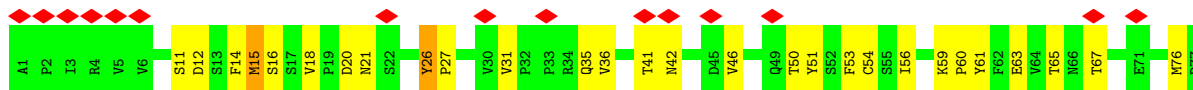
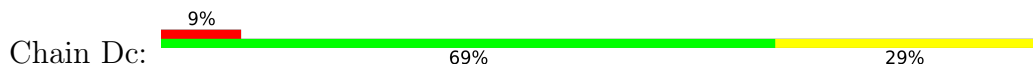

• Molecule 3: P1

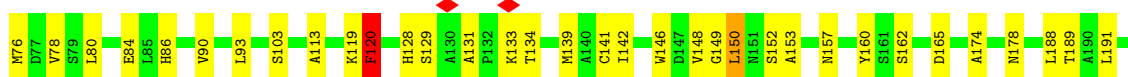
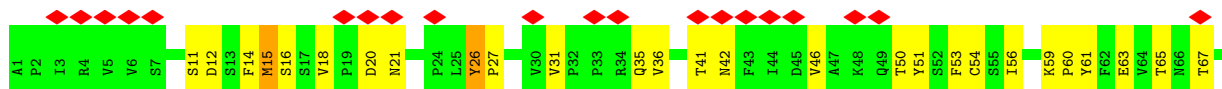

• Molecule 3: P1

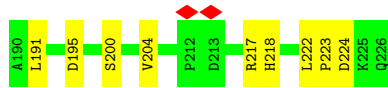
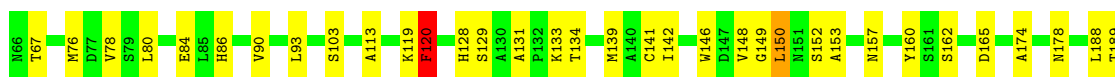
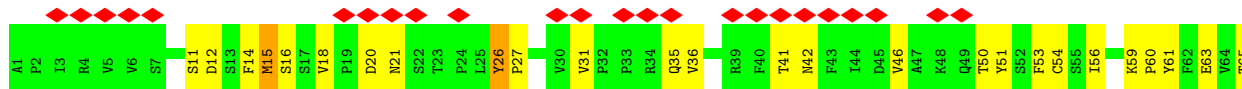

• Molecule 3: P1

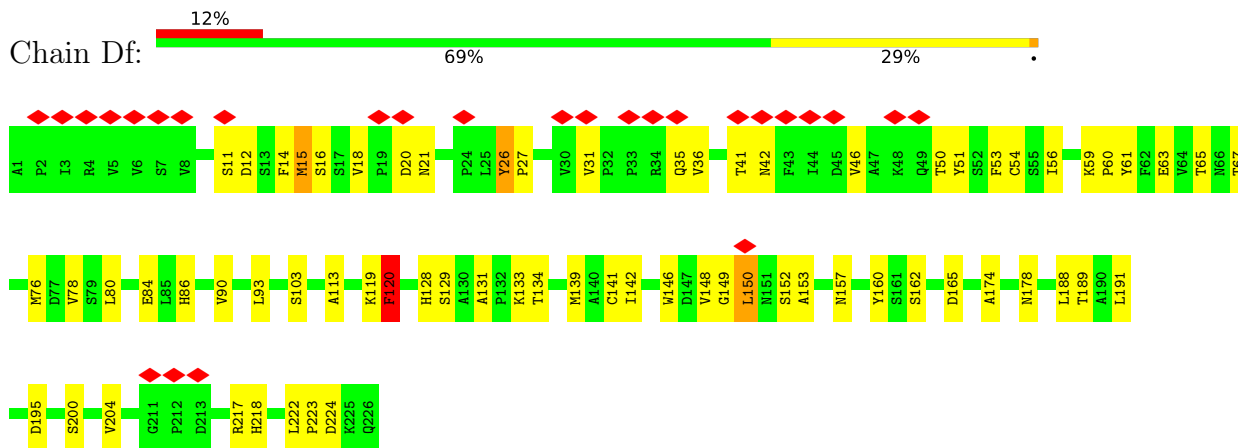

• Molecule 3: P1

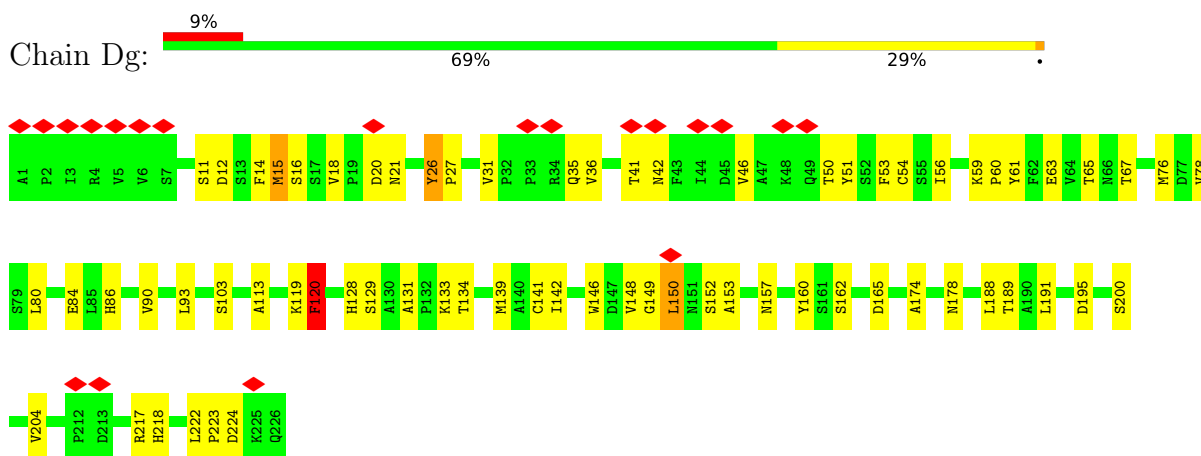

• Molecule 3: P1

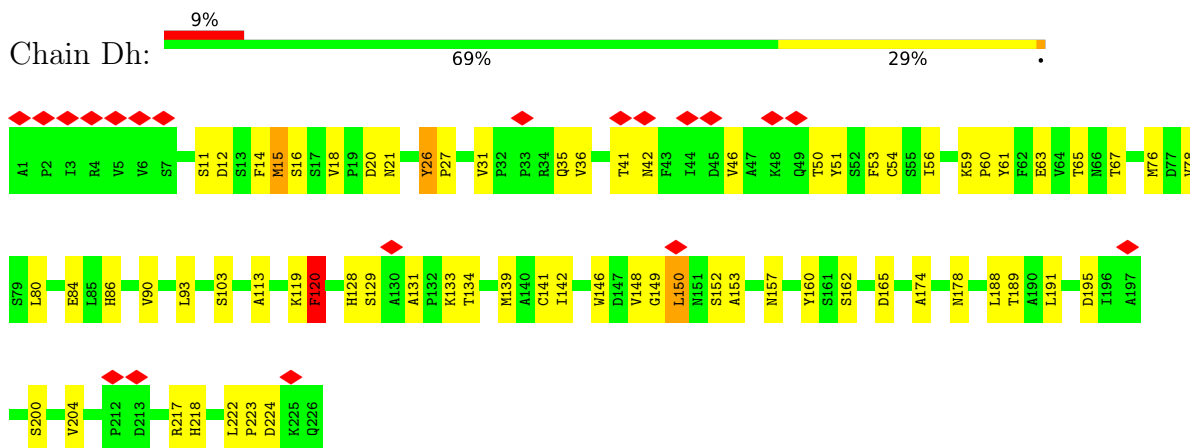

• Molecule 3: P1



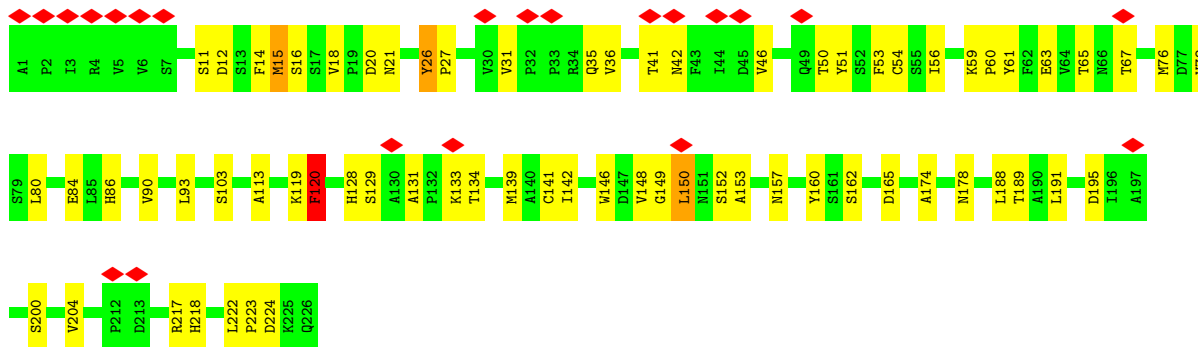

• Molecule 3: P1

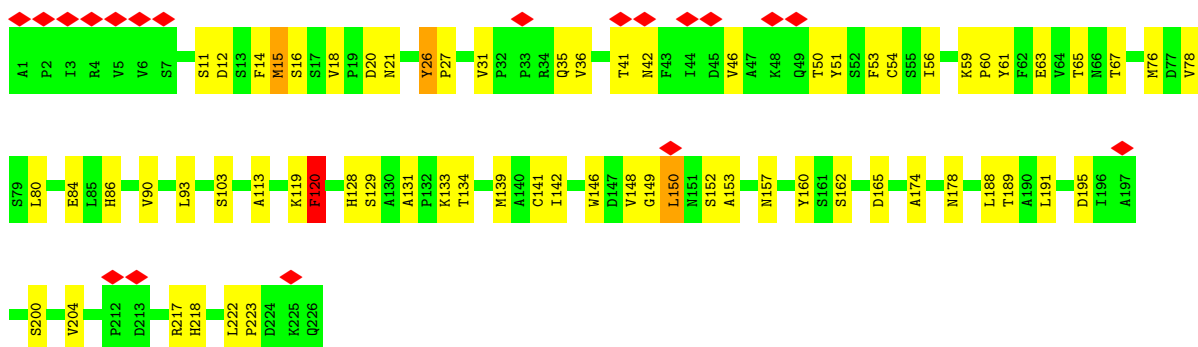

• Molecule 3: P1

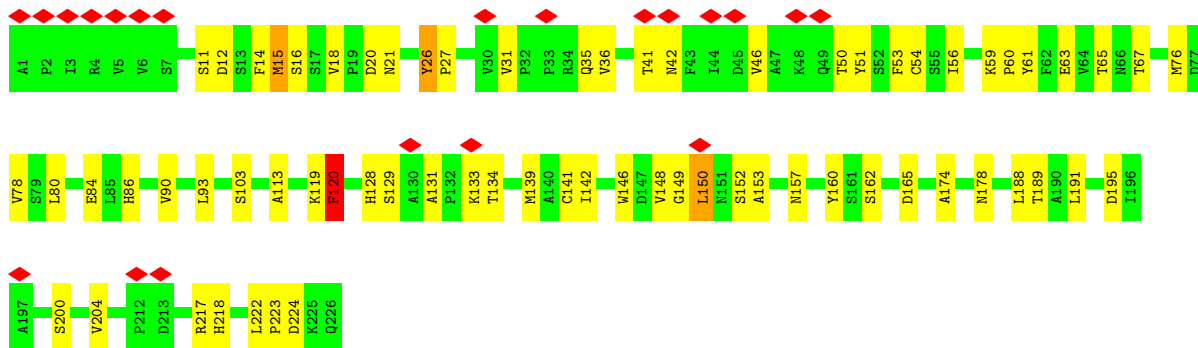

• Molecule 3: P1

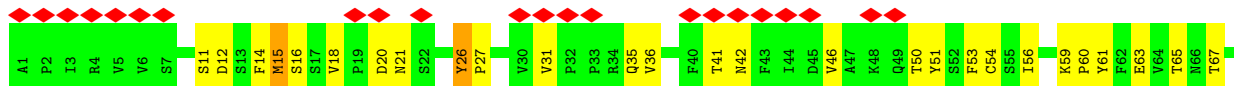

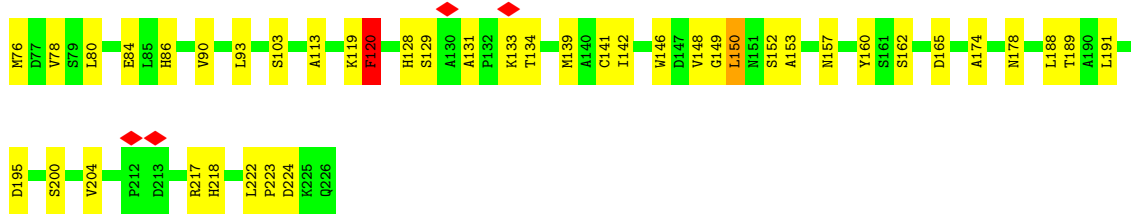

• Molecule 3: P1

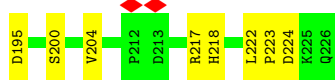
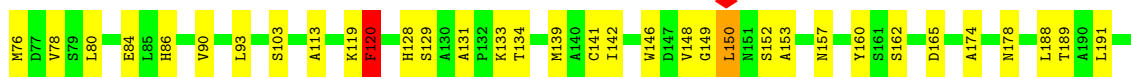
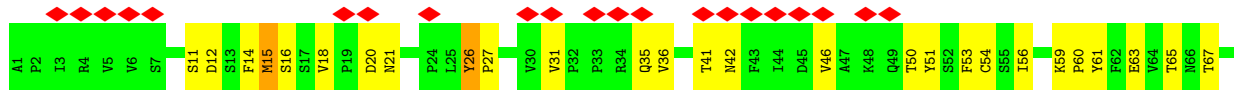
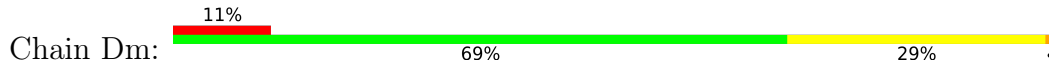

• Molecule 3: P1

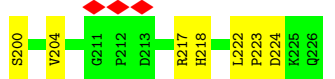
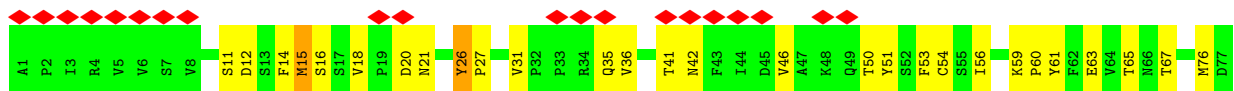

• Molecule 3: P1

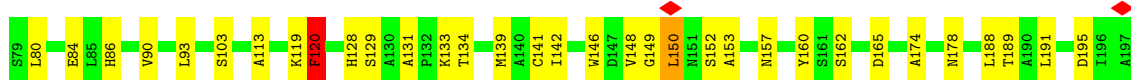
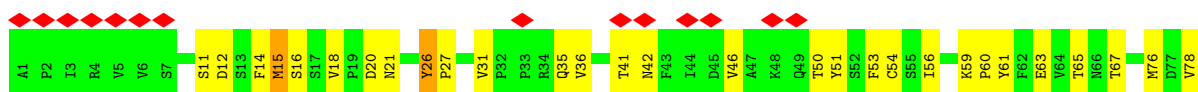

• Molecule 3: P1

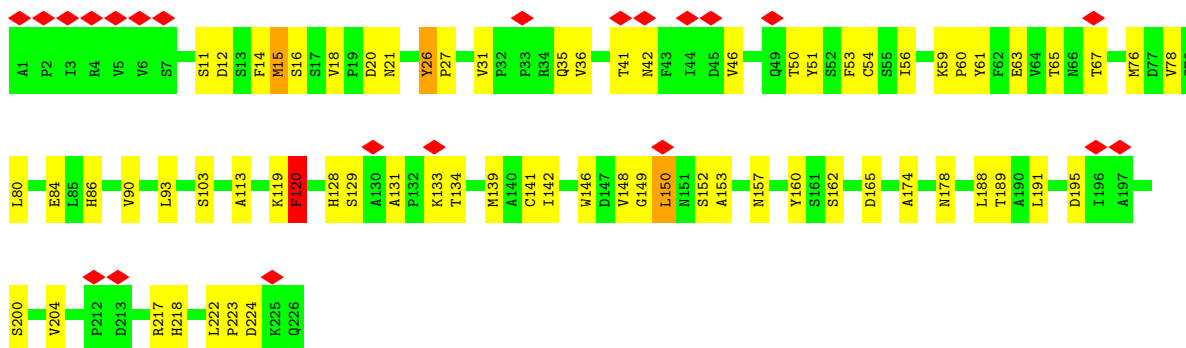
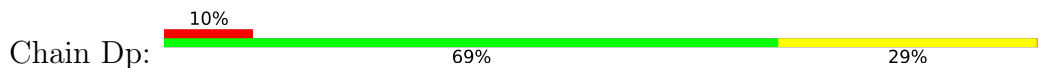

• Molecule 3: P1

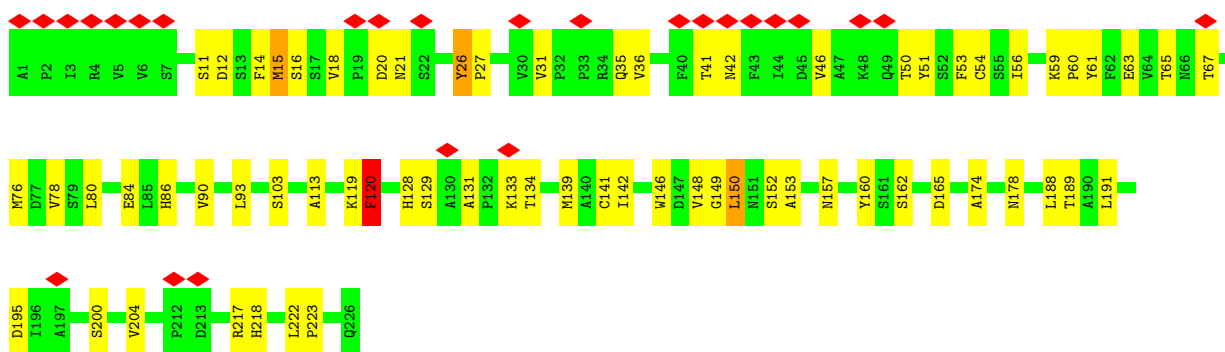
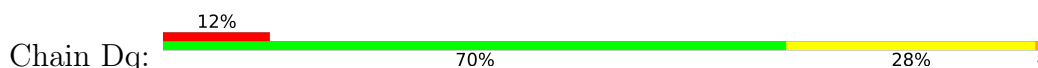

• Molecule 3: P1

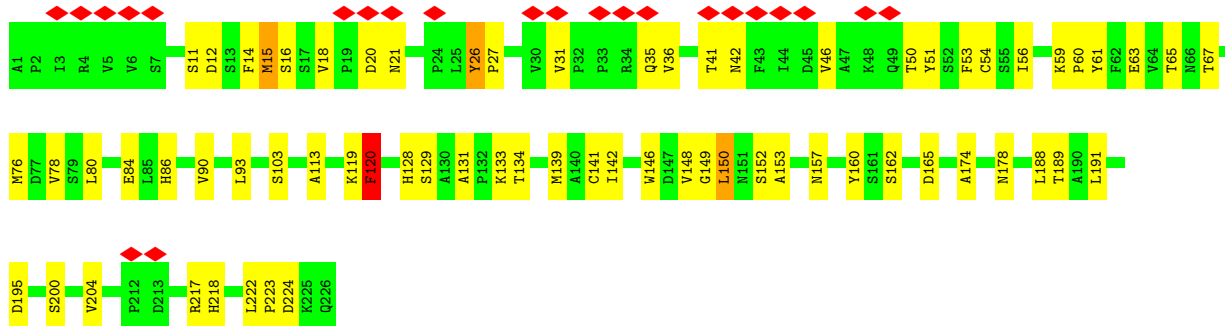

• Molecule 3: P1

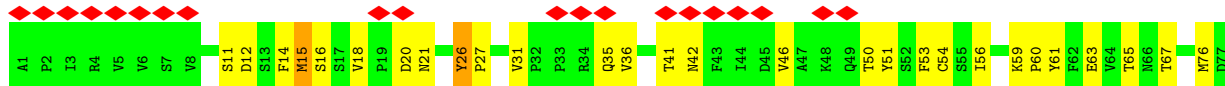

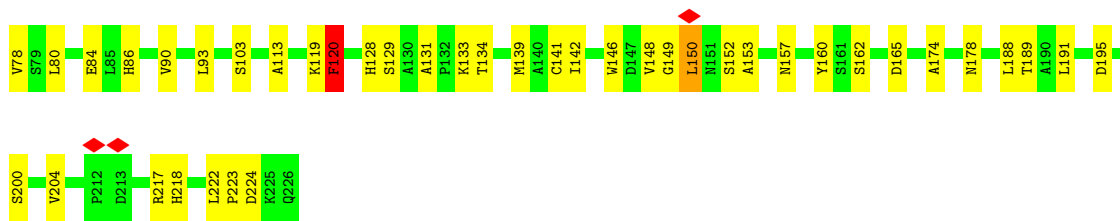

• Molecule 3: P1

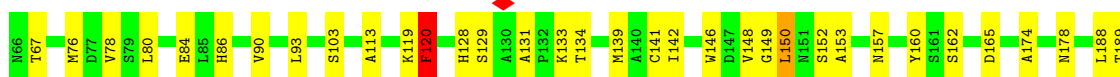

• Molecule 3: P1

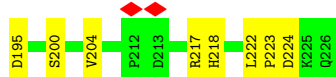

• Molecule 3: P1

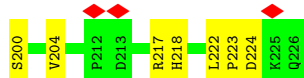
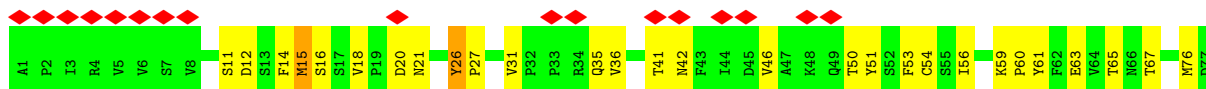

• Molecule 3: P1

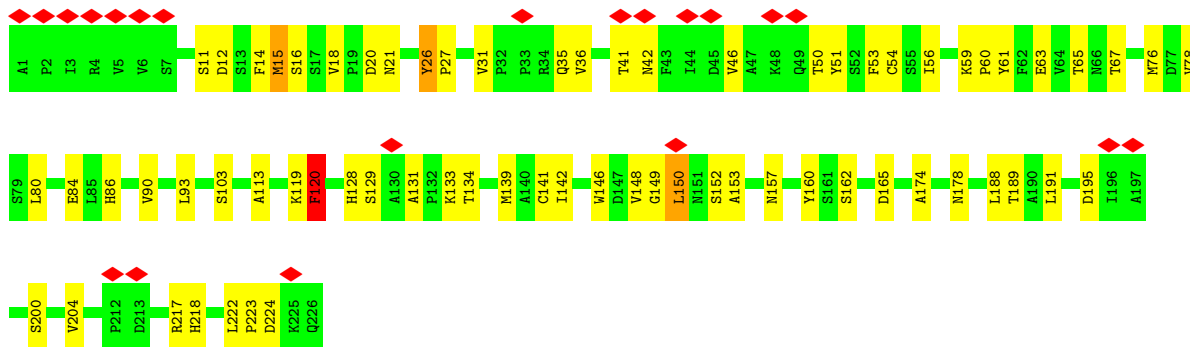
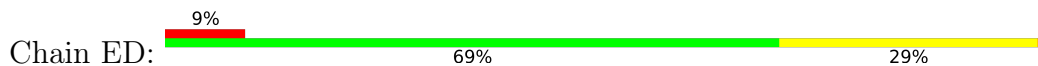

• Molecule 3: P1

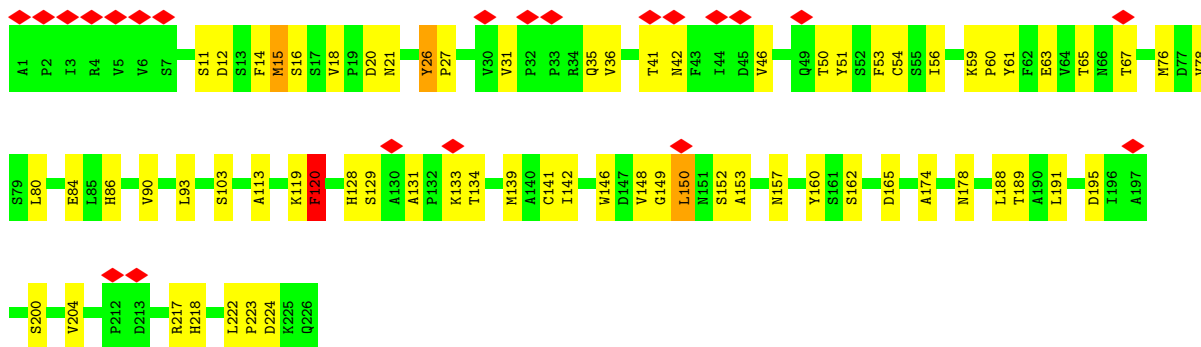

• Molecule 4: P1

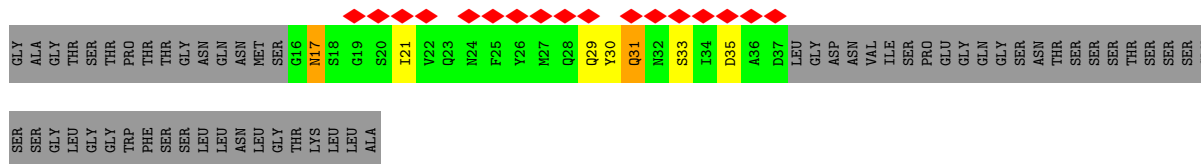

• Molecule 4: P1

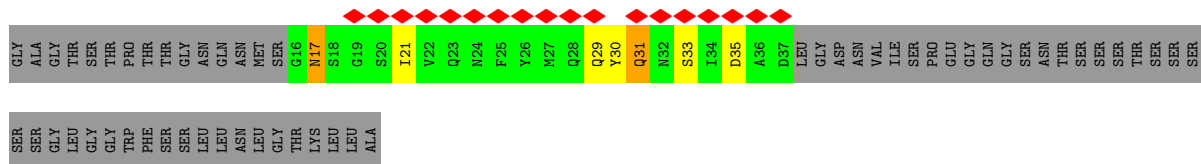

• Molecule 4: P1

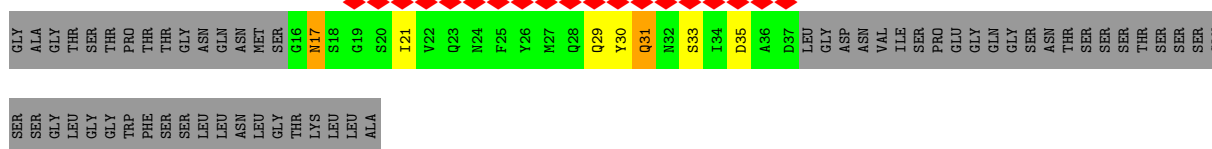

• Molecule 4: P1

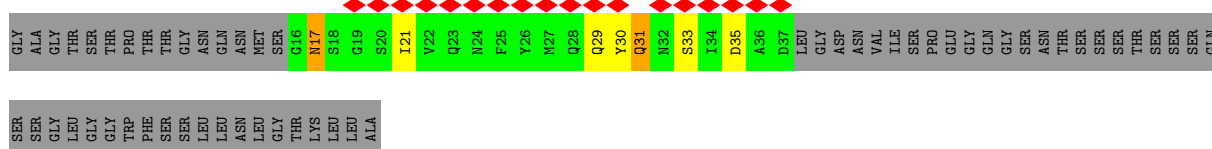

• Molecule 4: P1

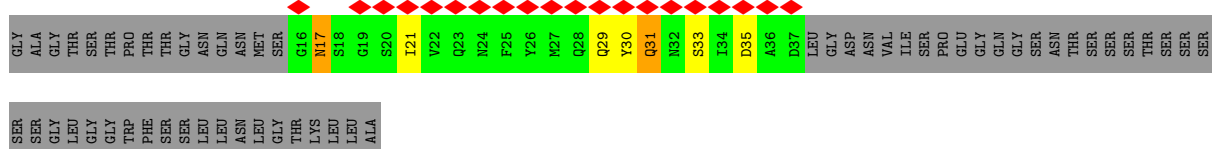

• Molecule 4: P1

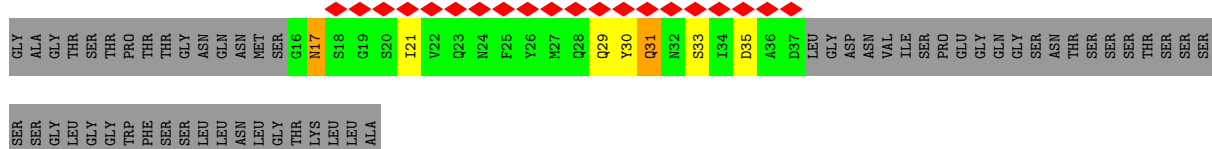

• Molecule 4: P1

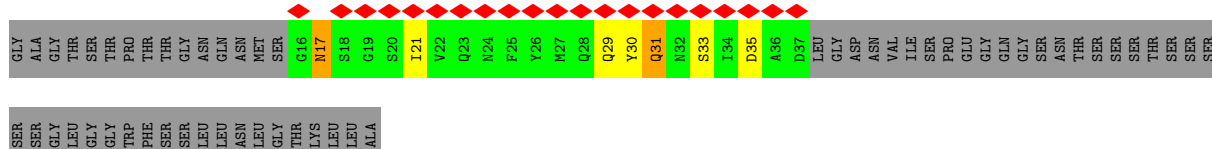

• Molecule 4: P1





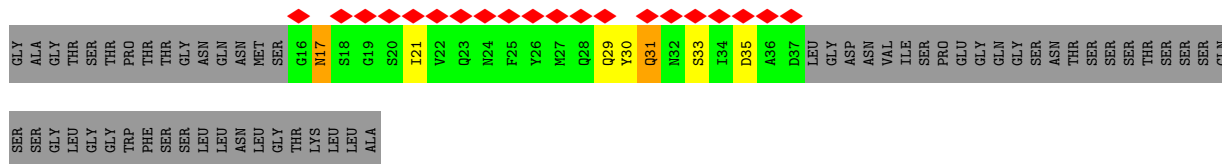

• Molecule 4: P1

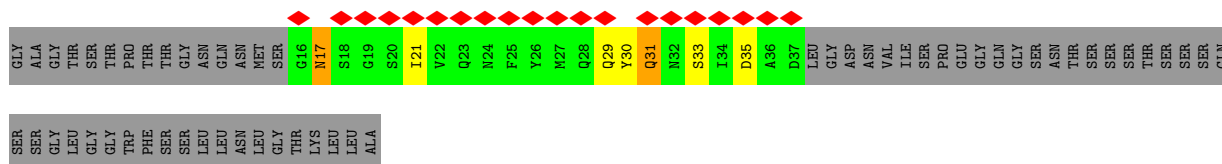

• Molecule 4: P1

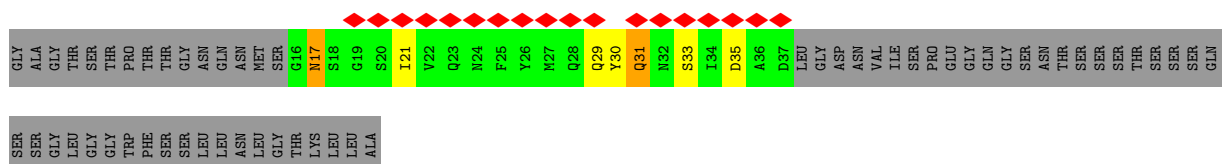

• Molecule 4: P1

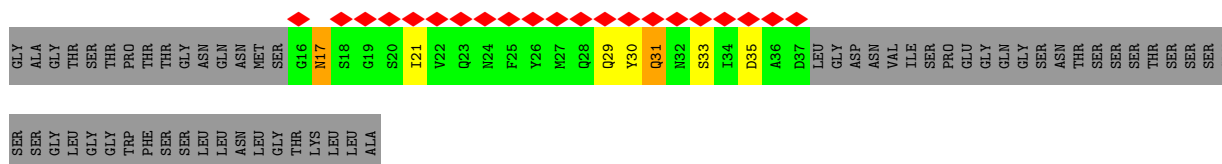

• Molecule 4: P1

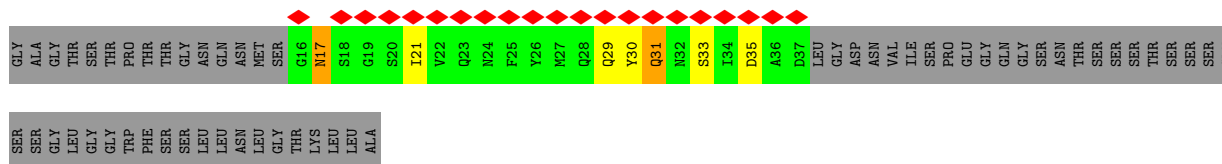

• Molecule 4: P1



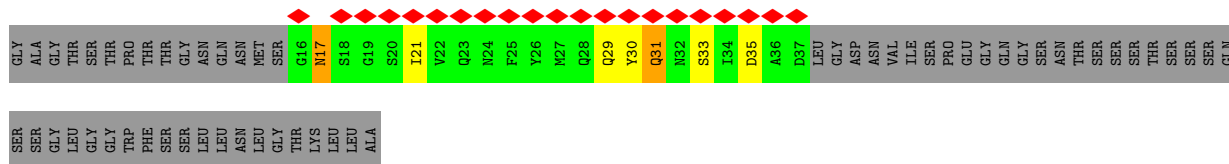

• Molecule 4: P1

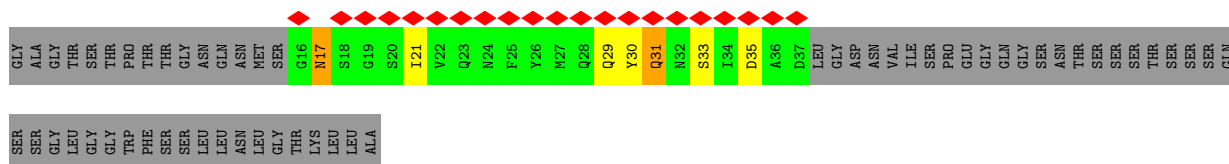

• Molecule 4: P1



• Molecule 4: P1

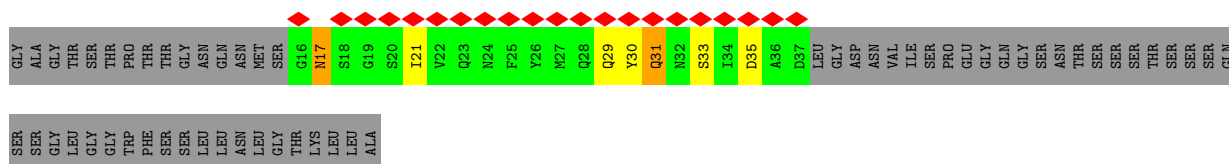

• Molecule 4: P1

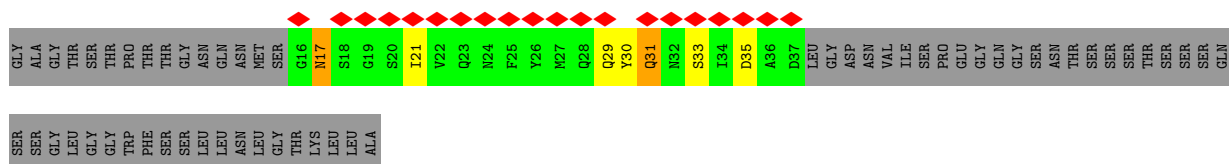

• Molecule 4: P1





• Molecule 4: P1

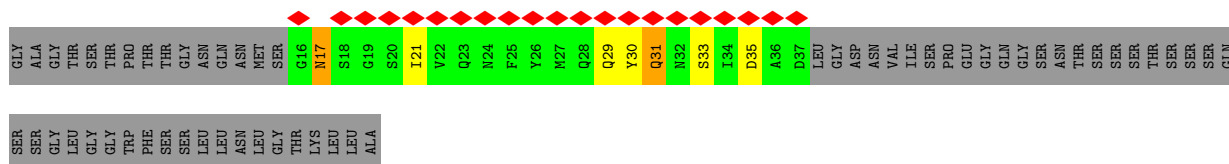

• Molecule 4: P1

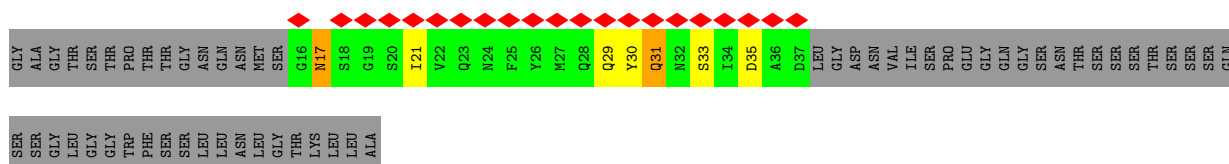

• Molecule 4: P1

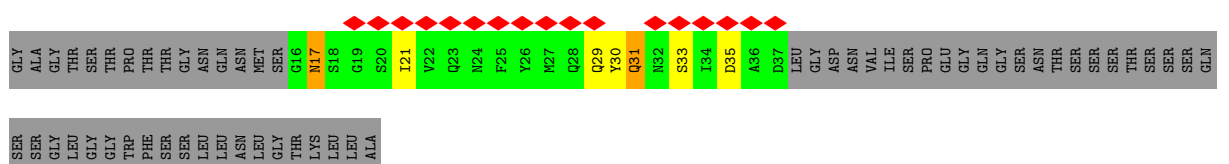

• Molecule 4: P1

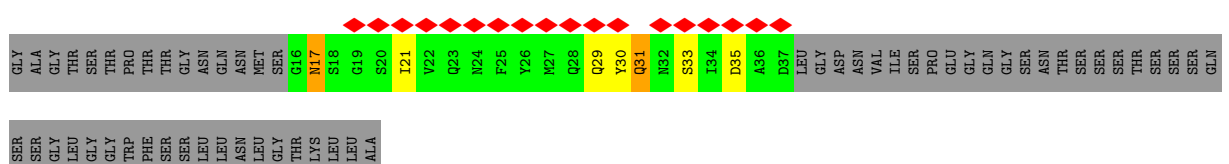

• Molecule 4: P1



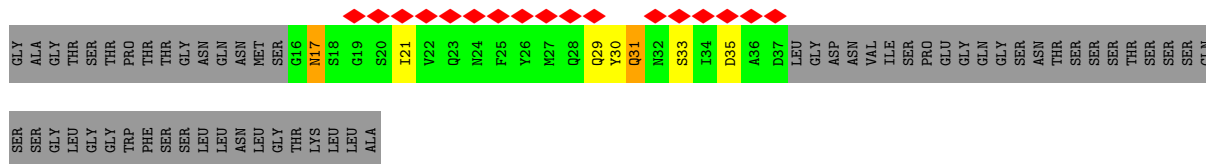

• Molecule 4: P1

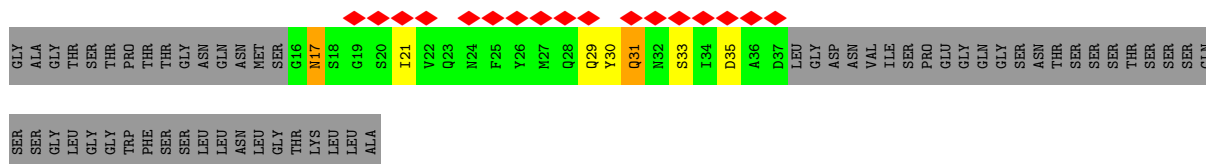

• Molecule 4: P1

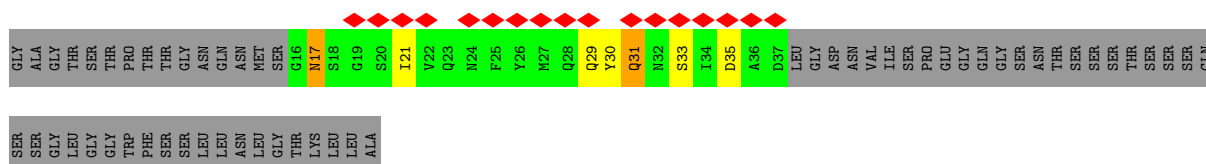

• Molecule 4: P1

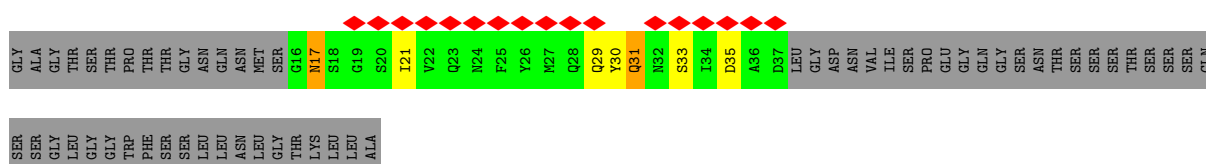

• Molecule 4: P1

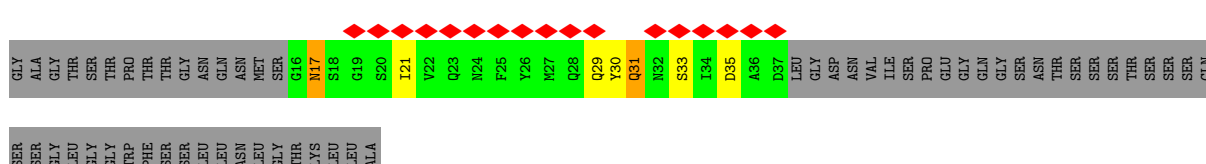

• Molecule 4: P1



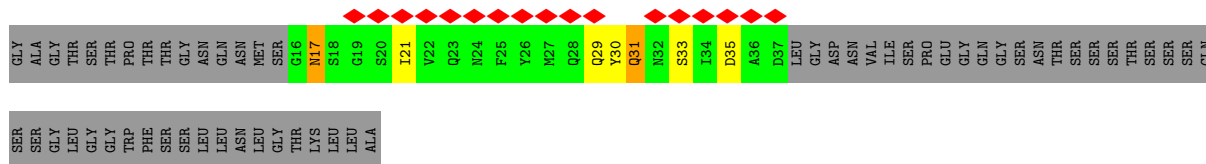

• Molecule 4: P1

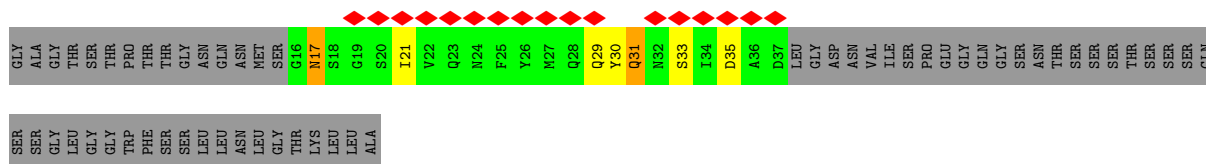

• Molecule 4: P1

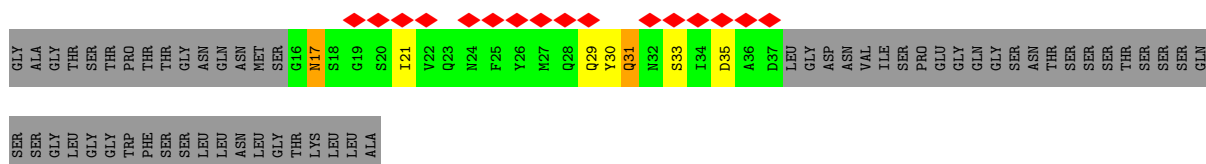

• Molecule 4: P1

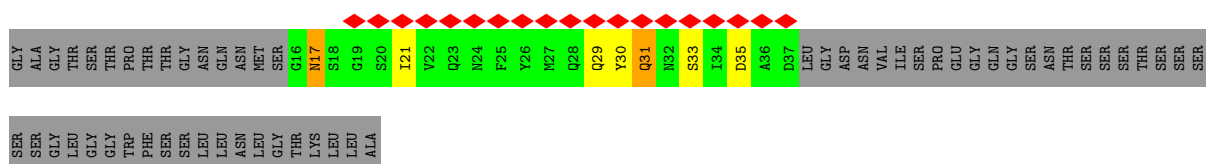

• Molecule 4: P1

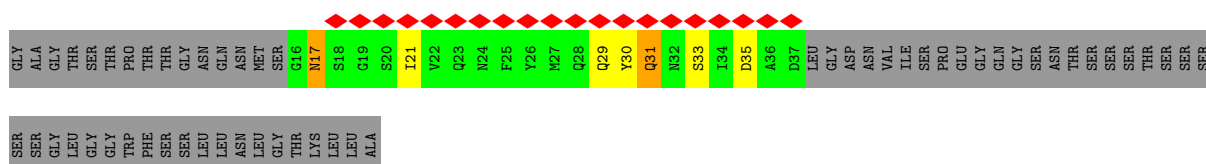

• Molecule 4: P1



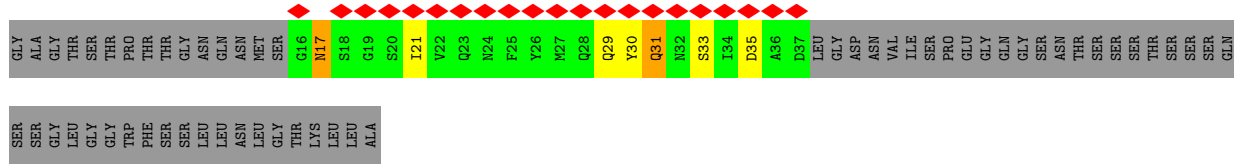

• Molecule 4: P1

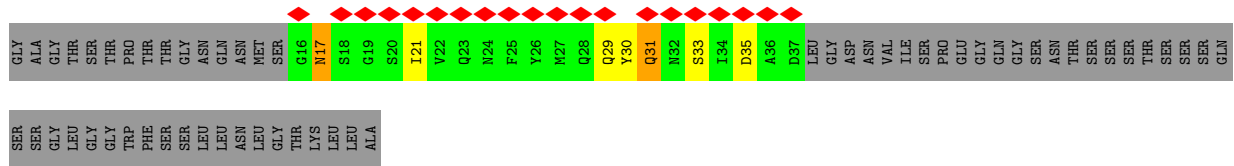

• Molecule 4: P1

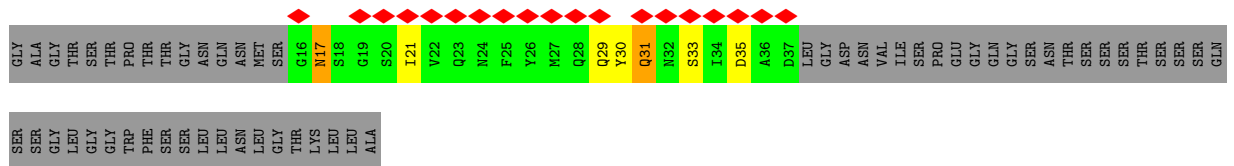

• Molecule 4: P1

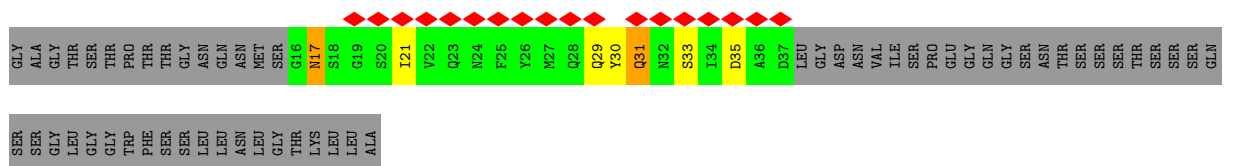

• Molecule 4: P1

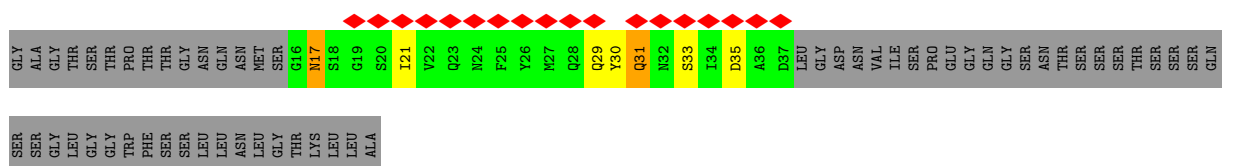

• Molecule 4: P1



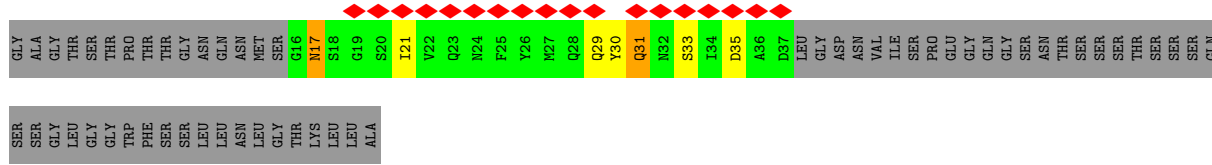

• Molecule 4: P1

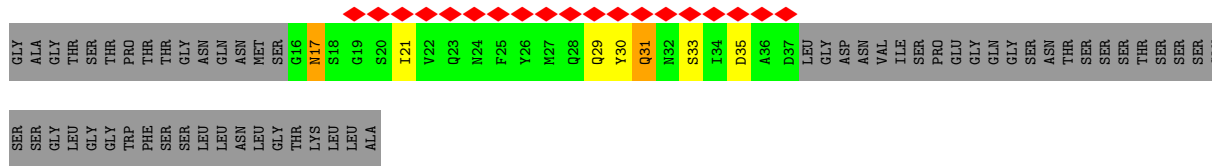

• Molecule 4: P1

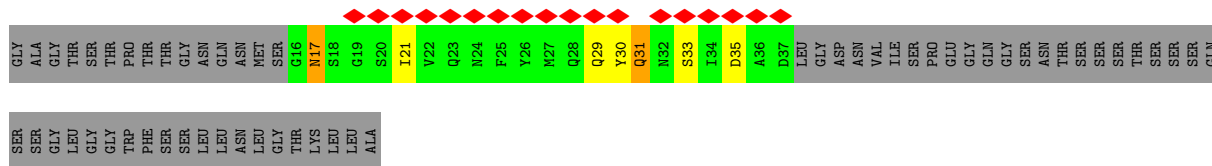

• Molecule 4: P1

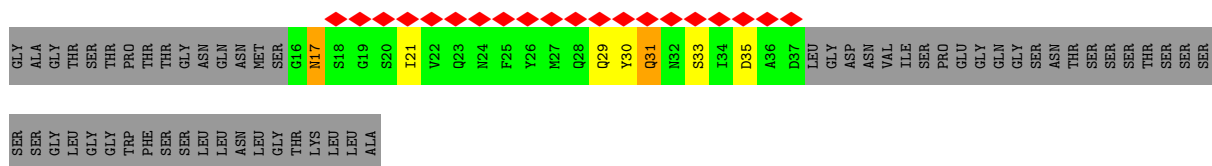

• Molecule 4: P1

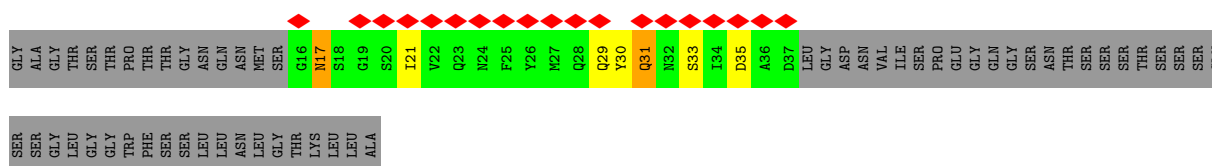

• Molecule 4: P1



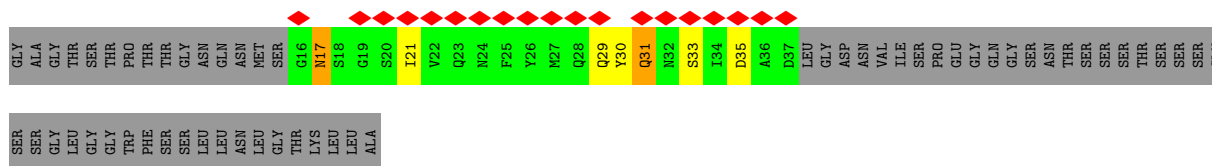

• Molecule 4: P1

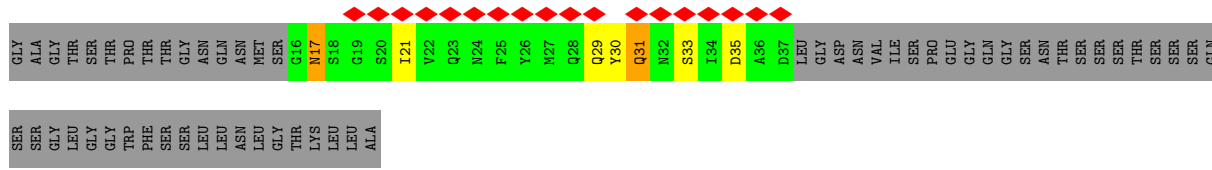

• Molecule 4: P1

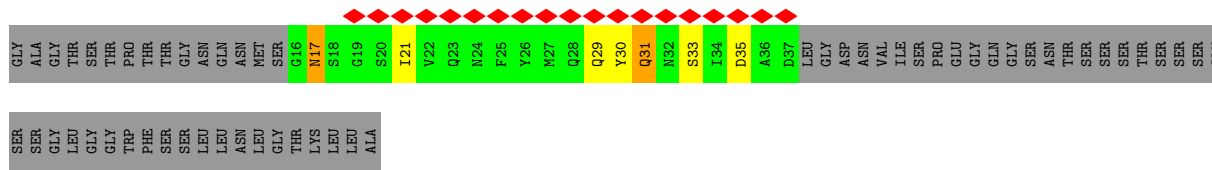

• Molecule 4: P1

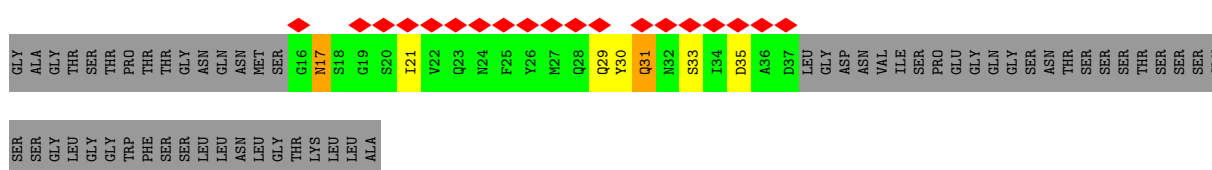

• Molecule 4: P1

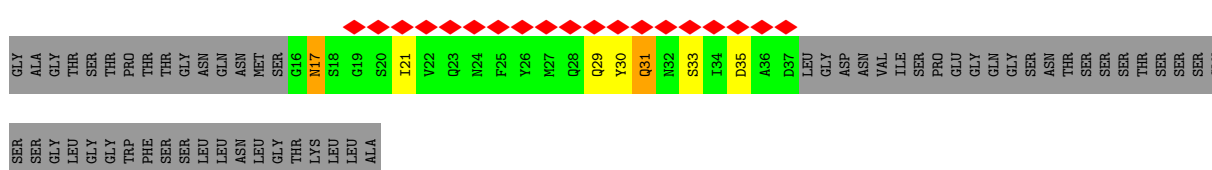

• Molecule 4: P1





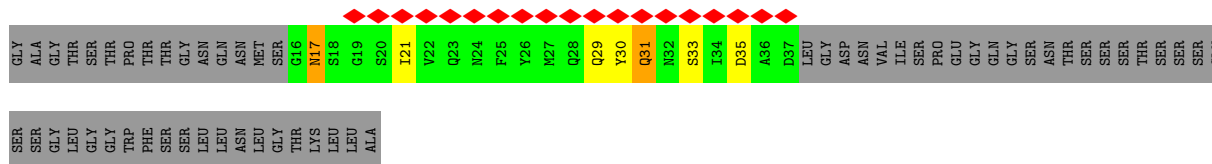

• Molecule 4: P1

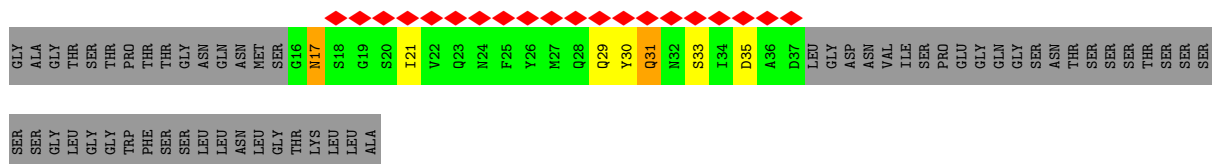

• Molecule 4: P1

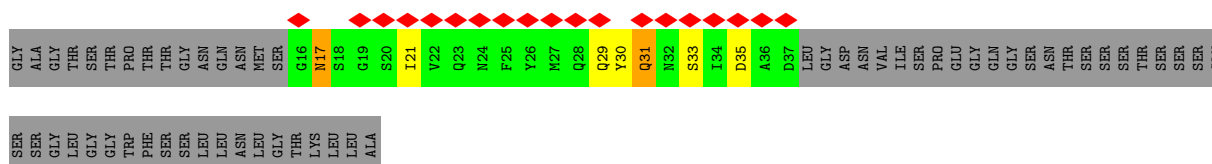

• Molecule 4: P1

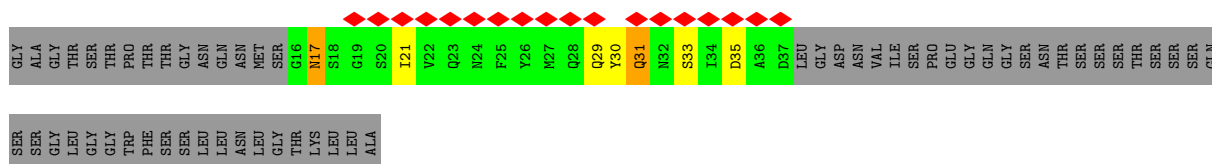

• Molecule 4: P1

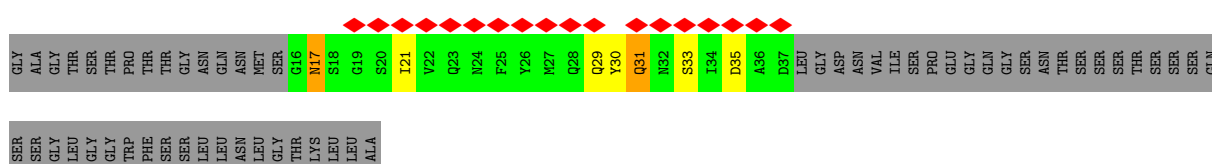

• Molecule 4: P1



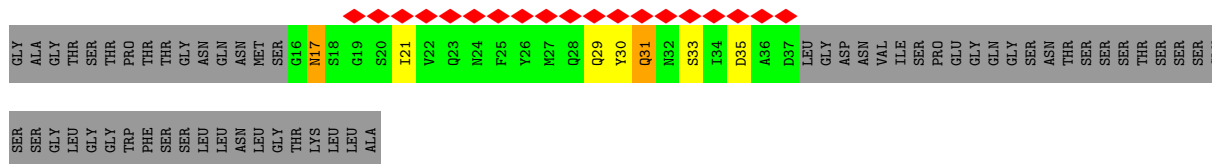

• Molecule 4: P1

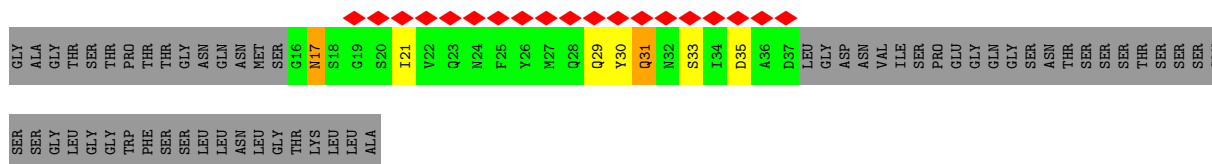

• Molecule 4: P1

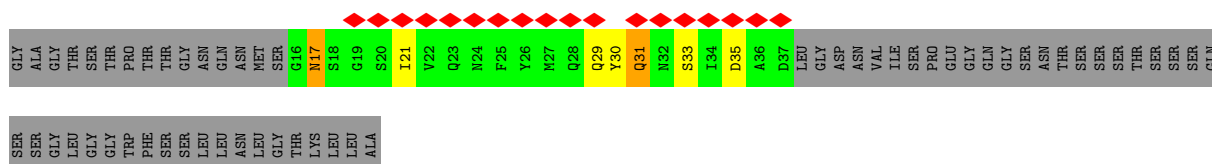

• Molecule 4: P1

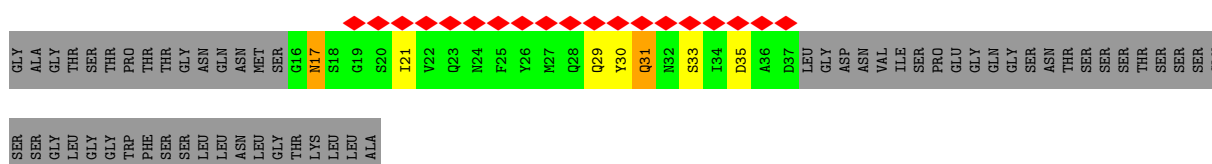

• Molecule 4: P1

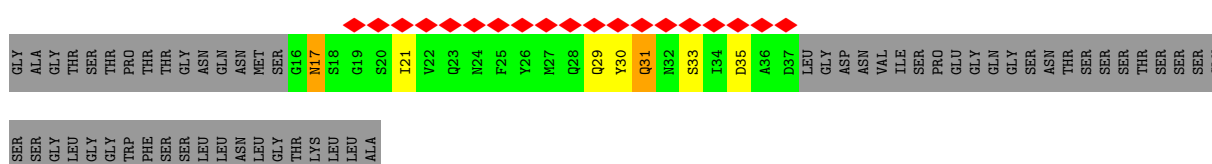

• Molecule 4: P1



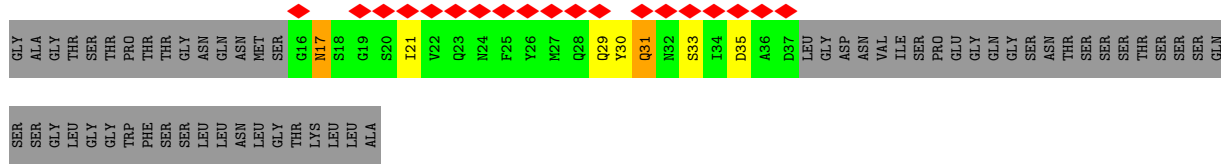

• Molecule 4: P1

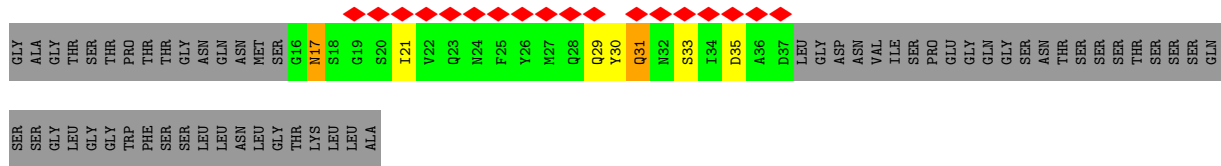

• Molecule 4: P1

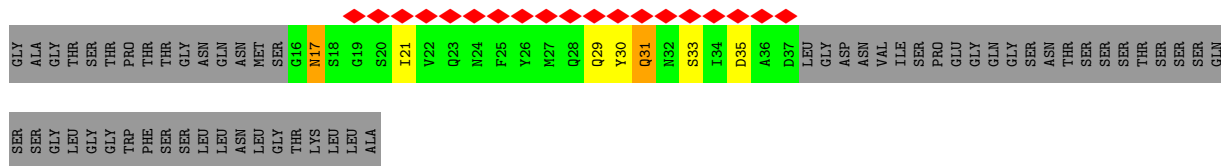

## 4 Experimental information

Property	Value	Source
EM reconstruction method	SINGLE PARTICLE	Depositor
Imposed symmetry	POINT, I	Depositor
Number of particles used	260	Depositor
Resolution determination method	Not provided	
CTF correction method	PHASE FLIPPING, EACH PARTICLE	Depositor
Microscope	FEI TECNAI F20	Depositor
Voltage (kV)	200	Depositor
Electron dose ( $e^-/\text{\AA}^2$ )	15	Depositor
Minimum defocus (nm)	Not provided	
Maximum defocus (nm)	Not provided	
Magnification	87209	Depositor
Image detector	GATAN ULTRASCAN 4000 (4k x 4k)	Depositor
Maximum map value	5.000	Depositor
Minimum map value	-4.614	Depositor
Average map value	0.058	Depositor
Map value standard deviation	1.018	Depositor
Recommended contour level	0.5	Depositor
Map size ( $\text{\AA}$ )	412.80002, 412.80002, 412.80002	wwPDB
Map dimensions	240, 240, 240	wwPDB
Map angles ( $^\circ$ )	90.0, 90.0, 90.0	wwPDB
Pixel spacing ( $\text{\AA}$ )	1.72, 1.72, 1.72	Depositor

## 5 Model quality i

### 5.1 Standard geometry i

The Z score for a bond length (or angle) is the number of standard deviations the observed value is removed from the expected value. A bond length (or angle) with  $|Z| > 5$  is considered an outlier worth inspection. RMSZ is the root-mean-square of all Z scores of the bond lengths (or angles).

Mol	Chain	Bond lengths		Bond angles	
		RMSZ	# Z  >5	RMSZ	# Z  >5
1	A0	0.84	1/1993 (0.1%)	1.07	6/2721 (0.2%)
1	A1	0.84	1/1993 (0.1%)	1.07	7/2721 (0.3%)
1	A2	0.84	1/1993 (0.1%)	1.07	5/2721 (0.2%)
1	A3	0.84	1/1993 (0.1%)	1.07	6/2721 (0.2%)
1	A4	0.84	1/1993 (0.1%)	1.07	6/2721 (0.2%)
1	A5	0.84	1/1993 (0.1%)	1.07	7/2721 (0.3%)
1	A6	0.84	1/1993 (0.1%)	1.07	7/2721 (0.3%)
1	A7	0.84	1/1993 (0.1%)	1.07	7/2721 (0.3%)
1	A8	0.84	1/1993 (0.1%)	1.07	6/2721 (0.2%)
1	A9	0.84	1/1993 (0.1%)	1.07	6/2721 (0.2%)
1	AA	0.84	1/1993 (0.1%)	1.07	6/2721 (0.2%)
1	AB	0.84	1/1993 (0.1%)	1.07	6/2721 (0.2%)
1	AC	0.84	1/1993 (0.1%)	1.07	6/2721 (0.2%)
1	AD	0.84	1/1993 (0.1%)	1.07	5/2721 (0.2%)
1	AE	0.84	1/1993 (0.1%)	1.07	7/2721 (0.3%)
1	AF	0.84	1/1993 (0.1%)	1.07	6/2721 (0.2%)
1	AG	0.84	1/1993 (0.1%)	1.07	6/2721 (0.2%)
1	AH	0.84	1/1993 (0.1%)	1.07	7/2721 (0.3%)
1	AI	0.84	1/1993 (0.1%)	1.07	6/2721 (0.2%)
1	AJ	0.84	1/1993 (0.1%)	1.07	6/2721 (0.2%)
1	AK	0.84	1/1993 (0.1%)	1.07	6/2721 (0.2%)
1	AL	0.84	1/1993 (0.1%)	1.07	6/2721 (0.2%)
1	AM	0.84	1/1993 (0.1%)	1.07	7/2721 (0.3%)
1	AN	0.84	1/1993 (0.1%)	1.07	6/2721 (0.2%)
1	AO	0.84	1/1993 (0.1%)	1.07	7/2721 (0.3%)
1	AP	0.84	1/1993 (0.1%)	1.07	6/2721 (0.2%)
1	AQ	0.84	1/1993 (0.1%)	1.07	6/2721 (0.2%)
1	AR	0.84	1/1993 (0.1%)	1.07	6/2721 (0.2%)
1	AS	0.84	1/1993 (0.1%)	1.07	6/2721 (0.2%)
1	AT	0.84	1/1993 (0.1%)	1.07	7/2721 (0.3%)
1	AU	0.84	1/1993 (0.1%)	1.07	6/2721 (0.2%)
1	AV	0.84	1/1993 (0.1%)	1.07	6/2721 (0.2%)
1	AW	0.84	1/1993 (0.1%)	1.07	6/2721 (0.2%)
1	AX	0.84	1/1993 (0.1%)	1.07	6/2721 (0.2%)

Mol	Chain	Bond lengths		Bond angles	
		RMSZ	# Z  >5	RMSZ	# Z  >5
1	AY	0.84	1/1993 (0.1%)	1.07	6/2721 (0.2%)
1	AZ	0.84	1/1993 (0.1%)	1.07	6/2721 (0.2%)
1	Aa	0.84	1/1993 (0.1%)	1.07	7/2721 (0.3%)
1	Ab	0.84	1/1993 (0.1%)	1.07	6/2721 (0.2%)
1	Ac	0.84	1/1993 (0.1%)	1.07	6/2721 (0.2%)
1	Ad	0.84	1/1993 (0.1%)	1.07	7/2721 (0.3%)
1	Ae	0.84	1/1993 (0.1%)	1.07	6/2721 (0.2%)
1	Af	0.84	1/1993 (0.1%)	1.07	7/2721 (0.3%)
1	Ag	0.84	1/1993 (0.1%)	1.07	7/2721 (0.3%)
1	Ah	0.84	1/1993 (0.1%)	1.07	6/2721 (0.2%)
1	Ai	0.84	1/1993 (0.1%)	1.07	6/2721 (0.2%)
1	Aj	0.84	1/1993 (0.1%)	1.07	6/2721 (0.2%)
1	Ak	0.84	1/1993 (0.1%)	1.07	6/2721 (0.2%)
1	Al	0.84	1/1993 (0.1%)	1.07	6/2721 (0.2%)
1	Am	0.84	1/1993 (0.1%)	1.07	6/2721 (0.2%)
1	An	0.84	1/1993 (0.1%)	1.07	6/2721 (0.2%)
1	Ao	0.84	1/1993 (0.1%)	1.07	6/2721 (0.2%)
1	BA	0.84	1/1993 (0.1%)	1.07	6/2721 (0.2%)
1	BB	0.84	1/1993 (0.1%)	1.07	6/2721 (0.2%)
1	BC	0.84	1/1993 (0.1%)	1.07	6/2721 (0.2%)
1	BD	0.84	1/1993 (0.1%)	1.07	6/2721 (0.2%)
1	BE	0.84	1/1993 (0.1%)	1.07	6/2721 (0.2%)
1	BF	0.84	1/1993 (0.1%)	1.07	6/2721 (0.2%)
1	BG	0.84	1/1993 (0.1%)	1.07	6/2721 (0.2%)
1	BH	0.84	1/1993 (0.1%)	1.07	6/2721 (0.2%)
1	BI	0.84	1/1993 (0.1%)	1.07	6/2721 (0.2%)
2	C0	0.86	1/1566 (0.1%)	1.18	8/2117 (0.4%)
2	C1	0.86	1/1566 (0.1%)	1.18	8/2117 (0.4%)
2	C2	0.86	1/1566 (0.1%)	1.18	8/2117 (0.4%)
2	C3	0.86	1/1566 (0.1%)	1.18	8/2117 (0.4%)
2	C4	0.86	1/1566 (0.1%)	1.18	8/2117 (0.4%)
2	C5	0.86	1/1566 (0.1%)	1.18	8/2117 (0.4%)
2	C6	0.86	1/1566 (0.1%)	1.18	8/2117 (0.4%)
2	C7	0.86	1/1566 (0.1%)	1.18	8/2117 (0.4%)
2	C8	0.86	1/1566 (0.1%)	1.18	8/2117 (0.4%)
2	C9	0.86	1/1566 (0.1%)	1.17	8/2117 (0.4%)
2	CA	0.86	1/1566 (0.1%)	1.18	8/2117 (0.4%)
2	CB	0.86	1/1566 (0.1%)	1.18	8/2117 (0.4%)
2	CC	0.86	1/1566 (0.1%)	1.17	8/2117 (0.4%)
2	CD	0.86	1/1566 (0.1%)	1.18	8/2117 (0.4%)
2	CE	0.86	1/1566 (0.1%)	1.17	8/2117 (0.4%)
2	CF	0.86	1/1566 (0.1%)	1.17	8/2117 (0.4%)
2	CG	0.86	1/1566 (0.1%)	1.18	8/2117 (0.4%)

Mol	Chain	Bond lengths		Bond angles	
		RMSZ	# Z  >5	RMSZ	# Z  >5
2	CH	0.86	1/1566 (0.1%)	1.18	8/2117 (0.4%)
2	CI	0.86	1/1566 (0.1%)	1.17	8/2117 (0.4%)
2	CJ	0.86	1/1566 (0.1%)	1.18	8/2117 (0.4%)
2	CK	0.86	1/1566 (0.1%)	1.18	8/2117 (0.4%)
2	CL	0.86	1/1566 (0.1%)	1.18	8/2117 (0.4%)
2	CM	0.86	1/1566 (0.1%)	1.17	8/2117 (0.4%)
2	CN	0.86	1/1566 (0.1%)	1.18	8/2117 (0.4%)
2	CO	0.86	1/1566 (0.1%)	1.17	8/2117 (0.4%)
2	CP	0.86	1/1566 (0.1%)	1.18	8/2117 (0.4%)
2	CQ	0.86	1/1566 (0.1%)	1.17	8/2117 (0.4%)
2	CR	0.86	1/1566 (0.1%)	1.18	8/2117 (0.4%)
2	CS	0.86	1/1566 (0.1%)	1.17	8/2117 (0.4%)
2	CT	0.86	1/1566 (0.1%)	1.17	8/2117 (0.4%)
2	CU	0.86	1/1566 (0.1%)	1.17	8/2117 (0.4%)
2	CV	0.86	1/1566 (0.1%)	1.17	8/2117 (0.4%)
2	CW	0.86	1/1566 (0.1%)	1.18	8/2117 (0.4%)
2	CX	0.86	1/1566 (0.1%)	1.18	8/2117 (0.4%)
2	CY	0.86	1/1566 (0.1%)	1.18	8/2117 (0.4%)
2	CZ	0.86	1/1566 (0.1%)	1.17	8/2117 (0.4%)
2	Ca	0.86	1/1566 (0.1%)	1.17	8/2117 (0.4%)
2	Cb	0.86	1/1566 (0.1%)	1.17	8/2117 (0.4%)
2	Cc	0.86	1/1566 (0.1%)	1.17	8/2117 (0.4%)
2	Cd	0.86	1/1566 (0.1%)	1.17	8/2117 (0.4%)
2	Ce	0.86	1/1566 (0.1%)	1.17	8/2117 (0.4%)
2	Cf	0.86	1/1566 (0.1%)	1.17	8/2117 (0.4%)
2	Cg	0.86	1/1566 (0.1%)	1.17	8/2117 (0.4%)
2	Ch	0.86	1/1566 (0.1%)	1.17	8/2117 (0.4%)
2	Ci	0.86	1/1566 (0.1%)	1.17	8/2117 (0.4%)
2	Cj	0.86	1/1566 (0.1%)	1.17	8/2117 (0.4%)
2	Ck	0.86	1/1566 (0.1%)	1.18	8/2117 (0.4%)
2	Cl	0.86	1/1566 (0.1%)	1.17	8/2117 (0.4%)
2	Cm	0.86	1/1566 (0.1%)	1.17	8/2117 (0.4%)
2	Cn	0.86	1/1566 (0.1%)	1.17	8/2117 (0.4%)
2	Co	0.86	1/1566 (0.1%)	1.18	8/2117 (0.4%)
2	Cp	0.86	1/1566 (0.1%)	1.18	8/2117 (0.4%)
2	Cq	0.86	1/1566 (0.1%)	1.17	8/2117 (0.4%)
2	Cr	0.86	1/1566 (0.1%)	1.17	8/2117 (0.4%)
2	Cs	0.86	1/1566 (0.1%)	1.18	8/2117 (0.4%)
2	Ct	0.86	1/1566 (0.1%)	1.17	8/2117 (0.4%)
2	Cu	0.86	1/1566 (0.1%)	1.17	8/2117 (0.4%)
2	Cv	0.86	1/1566 (0.1%)	1.17	8/2117 (0.4%)
2	Cw	0.86	1/1566 (0.1%)	1.17	8/2117 (0.4%)
2	Cx	0.86	1/1566 (0.1%)	1.18	8/2117 (0.4%)

Mol	Chain	Bond lengths		Bond angles	
		RMSZ	# Z  >5	RMSZ	# Z  >5
3	D0	0.87	5/1769 (0.3%)	1.12	7/2420 (0.3%)
3	D1	0.87	5/1769 (0.3%)	1.12	7/2420 (0.3%)
3	D2	0.87	5/1769 (0.3%)	1.12	7/2420 (0.3%)
3	D3	0.87	5/1769 (0.3%)	1.12	7/2420 (0.3%)
3	D4	0.87	5/1769 (0.3%)	1.12	7/2420 (0.3%)
3	D5	0.87	5/1769 (0.3%)	1.12	7/2420 (0.3%)
3	D6	0.87	5/1769 (0.3%)	1.12	7/2420 (0.3%)
3	D7	0.87	5/1769 (0.3%)	1.12	7/2420 (0.3%)
3	D8	0.87	5/1769 (0.3%)	1.12	7/2420 (0.3%)
3	D9	0.87	5/1769 (0.3%)	1.12	7/2420 (0.3%)
3	DA	0.87	5/1769 (0.3%)	1.12	7/2420 (0.3%)
3	DB	0.87	5/1769 (0.3%)	1.12	7/2420 (0.3%)
3	DC	0.87	5/1769 (0.3%)	1.12	7/2420 (0.3%)
3	DD	0.87	5/1769 (0.3%)	1.12	7/2420 (0.3%)
3	DE	0.87	5/1769 (0.3%)	1.12	7/2420 (0.3%)
3	DF	0.87	5/1769 (0.3%)	1.12	7/2420 (0.3%)
3	DG	0.87	5/1769 (0.3%)	1.12	7/2420 (0.3%)
3	DH	0.87	5/1769 (0.3%)	1.12	7/2420 (0.3%)
3	DI	0.87	5/1769 (0.3%)	1.12	7/2420 (0.3%)
3	DJ	0.87	5/1769 (0.3%)	1.13	7/2420 (0.3%)
3	DK	0.86	5/1769 (0.3%)	1.12	7/2420 (0.3%)
3	DL	0.87	5/1769 (0.3%)	1.12	7/2420 (0.3%)
3	DM	0.87	5/1769 (0.3%)	1.12	7/2420 (0.3%)
3	DN	0.87	5/1769 (0.3%)	1.12	7/2420 (0.3%)
3	DO	0.87	5/1769 (0.3%)	1.12	7/2420 (0.3%)
3	DP	0.87	5/1769 (0.3%)	1.12	7/2420 (0.3%)
3	DQ	0.87	5/1769 (0.3%)	1.12	7/2420 (0.3%)
3	DR	0.87	5/1769 (0.3%)	1.12	7/2420 (0.3%)
3	DS	0.87	5/1769 (0.3%)	1.12	7/2420 (0.3%)
3	DT	0.87	5/1769 (0.3%)	1.12	7/2420 (0.3%)
3	DU	0.87	5/1769 (0.3%)	1.12	7/2420 (0.3%)
3	DV	0.87	5/1769 (0.3%)	1.12	7/2420 (0.3%)
3	DW	0.87	5/1769 (0.3%)	1.12	7/2420 (0.3%)
3	DX	0.87	5/1769 (0.3%)	1.12	7/2420 (0.3%)
3	DY	0.87	5/1769 (0.3%)	1.12	7/2420 (0.3%)
3	DZ	0.87	5/1769 (0.3%)	1.12	7/2420 (0.3%)
3	Da	0.87	5/1769 (0.3%)	1.12	7/2420 (0.3%)
3	Db	0.87	5/1769 (0.3%)	1.12	7/2420 (0.3%)
3	Dc	0.87	5/1769 (0.3%)	1.12	7/2420 (0.3%)
3	Dd	0.87	5/1769 (0.3%)	1.12	7/2420 (0.3%)
3	De	0.87	5/1769 (0.3%)	1.12	7/2420 (0.3%)
3	Df	0.87	5/1769 (0.3%)	1.12	7/2420 (0.3%)
3	Dg	0.87	5/1769 (0.3%)	1.12	7/2420 (0.3%)



Mol	Chain	Bond lengths		Bond angles	
		RMSZ	# Z  >5	RMSZ	# Z  >5
3	Dh	0.87	5/1769 (0.3%)	1.12	7/2420 (0.3%)
3	Di	0.87	5/1769 (0.3%)	1.12	7/2420 (0.3%)
3	Dj	0.87	5/1769 (0.3%)	1.12	7/2420 (0.3%)
3	Dk	0.87	5/1769 (0.3%)	1.12	7/2420 (0.3%)
3	Dl	0.87	5/1769 (0.3%)	1.12	7/2420 (0.3%)
3	Dm	0.87	5/1769 (0.3%)	1.12	7/2420 (0.3%)
3	Dn	0.87	5/1769 (0.3%)	1.12	7/2420 (0.3%)
3	Do	0.87	5/1769 (0.3%)	1.12	7/2420 (0.3%)
3	Dp	0.87	5/1769 (0.3%)	1.12	7/2420 (0.3%)
3	Dq	0.87	5/1769 (0.3%)	1.12	7/2420 (0.3%)
3	Dr	0.87	5/1769 (0.3%)	1.12	7/2420 (0.3%)
3	Ds	0.86	5/1769 (0.3%)	1.12	7/2420 (0.3%)
3	EA	0.87	5/1769 (0.3%)	1.12	7/2420 (0.3%)
3	EB	0.87	5/1769 (0.3%)	1.12	7/2420 (0.3%)
3	EC	0.87	5/1769 (0.3%)	1.12	7/2420 (0.3%)
3	ED	0.87	5/1769 (0.3%)	1.12	7/2420 (0.3%)
3	EE	0.87	5/1769 (0.3%)	1.12	7/2420 (0.3%)
4	F0	0.78	0/168	1.03	0/226
4	F1	0.78	0/168	1.03	0/226
4	F2	0.78	0/168	1.03	0/226
4	F3	0.78	0/168	1.03	0/226
4	F4	0.78	0/168	1.03	0/226
4	F5	0.78	0/168	1.03	0/226
4	F6	0.77	0/168	1.03	0/226
4	F7	0.78	0/168	1.03	0/226
4	F8	0.78	0/168	1.03	0/226
4	F9	0.78	0/168	1.03	0/226
4	FA	0.78	0/168	1.03	0/226
4	FB	0.78	0/168	1.03	0/226
4	FC	0.78	0/168	1.03	0/226
4	FD	0.78	0/168	1.03	0/226
4	FE	0.78	0/168	1.03	0/226
4	FF	0.78	0/168	1.03	0/226
4	FG	0.78	0/168	1.03	0/226
4	FH	0.78	0/168	1.03	0/226
4	FI	0.78	0/168	1.03	0/226
4	FJ	0.78	0/168	1.03	0/226
4	FK	0.78	0/168	1.03	0/226
4	FL	0.78	0/168	1.03	0/226
4	FM	0.78	0/168	1.03	0/226
4	FN	0.78	0/168	1.03	0/226
4	FO	0.78	0/168	1.03	0/226
4	FP	0.78	0/168	1.03	0/226

Mol	Chain	Bond lengths		Bond angles	
		RMSZ	# Z  >5	RMSZ	# Z  >5
4	FQ	0.78	0/168	1.03	0/226
4	FR	0.78	0/168	1.03	0/226
4	FS	0.77	0/168	1.03	0/226
4	FT	0.78	0/168	1.03	0/226
4	FU	0.78	0/168	1.03	0/226
4	FV	0.78	0/168	1.03	0/226
4	FW	0.78	0/168	1.03	0/226
4	FX	0.78	0/168	1.03	0/226
4	FY	0.78	0/168	1.03	0/226
4	FZ	0.77	0/168	1.03	0/226
4	Fa	0.78	0/168	1.03	0/226
4	Fb	0.78	0/168	1.03	0/226
4	Fc	0.78	0/168	1.03	0/226
4	Fd	0.77	0/168	1.03	0/226
4	Fe	0.78	0/168	1.03	0/226
4	Ff	0.78	0/168	1.03	0/226
4	Fg	0.78	0/168	1.03	0/226
4	Fh	0.78	0/168	1.03	0/226
4	Fi	0.78	0/168	1.03	0/226
4	Fj	0.78	0/168	1.03	0/226
4	Fk	0.78	0/168	1.03	0/226
4	Fl	0.78	0/168	1.03	0/226
4	Fm	0.78	0/168	1.03	0/226
4	Fn	0.77	0/168	1.03	0/226
4	Fo	0.78	0/168	1.03	0/226
4	Fp	0.78	0/168	1.03	0/226
4	Fq	0.78	0/168	1.03	0/226
4	Fr	0.78	0/168	1.03	0/226
4	Fs	0.78	0/168	1.03	0/226
4	Ft	0.78	0/168	1.03	0/226
4	Fu	0.78	0/168	1.03	0/226
4	Fv	0.78	0/168	1.03	0/226
4	Fw	0.78	0/168	1.03	0/226
4	Fx	0.78	0/168	1.03	0/226
All	All	0.85	420/329760 (0.1%)	1.12	1271/449040 (0.3%)

Chiral center outliers are detected by calculating the chiral volume of a chiral center and verifying if the center is modelled as a planar moiety or with the opposite hand. A planarity outlier is detected by checking planarity of atoms in a peptide group, atoms in a mainchain group or atoms of a sidechain that are expected to be planar.

Mol	Chain	#Chirality outliers	#Planarity outliers
3	D0	0	2

*Continued on next page...*

*Continued from previous page...*

Mol	Chain	#Chirality outliers	#Planarity outliers
3	D1	0	2
3	D2	0	2
3	D3	0	2
3	D4	0	2
3	D5	0	2
3	D6	0	2
3	D7	0	2
3	D8	0	2
3	D9	0	2
3	DA	0	2
3	DB	0	2
3	DC	0	2
3	DD	0	2
3	DE	0	2
3	DF	0	2
3	DG	0	2
3	DH	0	2
3	DI	0	2
3	DJ	0	2
3	DK	0	2
3	DL	0	2
3	DM	0	2
3	DN	0	2
3	DO	0	2
3	DP	0	2
3	DQ	0	2
3	DR	0	2
3	DS	0	2
3	DT	0	2
3	DU	0	2
3	DV	0	2
3	DW	0	2
3	DX	0	2
3	DY	0	2
3	DZ	0	2
3	Da	0	2
3	Db	0	2
3	Dc	0	2
3	Dd	0	2
3	De	0	2
3	Df	0	2
3	Dg	0	2

*Continued on next page...*

*Continued from previous page...*

Mol	Chain	#Chirality outliers	#Planarity outliers
3	Dh	0	2
3	Di	0	2
3	Dj	0	2
3	Dk	0	2
3	Dl	0	2
3	Dm	0	2
3	Dn	0	2
3	Do	0	2
3	Dp	0	2
3	Dq	0	2
3	Dr	0	2
3	Ds	0	2
3	EA	0	2
3	EB	0	2
3	EC	0	2
3	ED	0	2
3	EE	0	2
All	All	0	120

The worst 5 of 420 bond length outliers are listed below:

Mol	Chain	Res	Type	Atoms	Z	Observed(Å)	Ideal(Å)
3	DO	119	LYS	CE-NZ	7.44	1.67	1.49
3	DS	119	LYS	CE-NZ	7.43	1.67	1.49
3	DG	119	LYS	CE-NZ	7.42	1.67	1.49
3	D3	119	LYS	CE-NZ	7.42	1.67	1.49
3	Dr	119	LYS	CE-NZ	7.42	1.67	1.49

The worst 5 of 1271 bond angle outliers are listed below:

Mol	Chain	Res	Type	Atoms	Z	Observed(°)	Ideal(°)
2	Cx	58	LEU	CA-CB-CG	9.46	137.05	115.30
2	C2	58	LEU	CA-CB-CG	9.45	137.04	115.30
2	CB	58	LEU	CA-CB-CG	9.46	137.05	115.30
2	Cn	58	LEU	CA-CB-CG	9.45	137.04	115.30
2	CC	58	LEU	CA-CB-CG	9.45	137.03	115.30

There are no chirality outliers.

5 of 120 planarity outliers are listed below:

Mol	Chain	Res	Type	Group
3	D0	26	TYR	Sidechain
3	D0	53	PHE	Sidechain
3	D1	26	TYR	Sidechain
3	D1	53	PHE	Sidechain
3	D2	26	TYR	Sidechain

## 5.2 Too-close contacts [i](#)

Due to software issues we are unable to calculate clashes - this section is therefore empty.

## 5.3 Torsion angles [i](#)

### 5.3.1 Protein backbone [i](#)

In the following table, the Percentiles column shows the percent Ramachandran outliers of the chain as a percentile score with respect to all PDB entries followed by that with respect to all EM entries.

The Analysed column shows the number of residues for which the backbone conformation was analysed, and the total number of residues.

Mol	Chain	Analysed	Favoured	Allowed	Outliers	Percentiles	
1	A0	244/246 (99%)	145 (59%)	59 (24%)	40 (16%)	0	3
1	A1	244/246 (99%)	145 (59%)	59 (24%)	40 (16%)	0	3
1	A2	244/246 (99%)	145 (59%)	59 (24%)	40 (16%)	0	3
1	A3	244/246 (99%)	145 (59%)	59 (24%)	40 (16%)	0	3
1	A4	244/246 (99%)	145 (59%)	59 (24%)	40 (16%)	0	3
1	A5	244/246 (99%)	145 (59%)	59 (24%)	40 (16%)	0	3
1	A6	244/246 (99%)	145 (59%)	59 (24%)	40 (16%)	0	3
1	A7	244/246 (99%)	145 (59%)	59 (24%)	40 (16%)	0	3
1	A8	244/246 (99%)	145 (59%)	59 (24%)	40 (16%)	0	3
1	A9	244/246 (99%)	145 (59%)	59 (24%)	40 (16%)	0	3
1	AA	244/246 (99%)	145 (59%)	59 (24%)	40 (16%)	0	3
1	AB	244/246 (99%)	145 (59%)	59 (24%)	40 (16%)	0	3
1	AC	244/246 (99%)	145 (59%)	59 (24%)	40 (16%)	0	3
1	AD	244/246 (99%)	145 (59%)	59 (24%)	40 (16%)	0	3
1	AE	244/246 (99%)	145 (59%)	59 (24%)	40 (16%)	0	3

*Continued on next page...*

*Continued from previous page...*

Mol	Chain	Analysed	Favoured	Allowed	Outliers	Percentiles	
1	AF	244/246 (99%)	145 (59%)	59 (24%)	40 (16%)	0	3
1	AG	244/246 (99%)	145 (59%)	59 (24%)	40 (16%)	0	3
1	AH	244/246 (99%)	144 (59%)	60 (25%)	40 (16%)	0	3
1	AI	244/246 (99%)	144 (59%)	60 (25%)	40 (16%)	0	3
1	AJ	244/246 (99%)	145 (59%)	59 (24%)	40 (16%)	0	3
1	AK	244/246 (99%)	144 (59%)	60 (25%)	40 (16%)	0	3
1	AL	244/246 (99%)	145 (59%)	59 (24%)	40 (16%)	0	3
1	AM	244/246 (99%)	144 (59%)	60 (25%)	40 (16%)	0	3
1	AN	244/246 (99%)	145 (59%)	59 (24%)	40 (16%)	0	3
1	AO	244/246 (99%)	145 (59%)	59 (24%)	40 (16%)	0	3
1	AP	244/246 (99%)	145 (59%)	59 (24%)	40 (16%)	0	3
1	AQ	244/246 (99%)	145 (59%)	59 (24%)	40 (16%)	0	3
1	AR	244/246 (99%)	145 (59%)	59 (24%)	40 (16%)	0	3
1	AS	244/246 (99%)	144 (59%)	60 (25%)	40 (16%)	0	3
1	AT	244/246 (99%)	145 (59%)	59 (24%)	40 (16%)	0	3
1	AU	244/246 (99%)	145 (59%)	59 (24%)	40 (16%)	0	3
1	AV	244/246 (99%)	145 (59%)	59 (24%)	40 (16%)	0	3
1	AW	244/246 (99%)	145 (59%)	59 (24%)	40 (16%)	0	3
1	AX	244/246 (99%)	145 (59%)	59 (24%)	40 (16%)	0	3
1	AY	244/246 (99%)	145 (59%)	59 (24%)	40 (16%)	0	3
1	AZ	244/246 (99%)	144 (59%)	60 (25%)	40 (16%)	0	3
1	Aa	244/246 (99%)	145 (59%)	59 (24%)	40 (16%)	0	3
1	Ab	244/246 (99%)	144 (59%)	60 (25%)	40 (16%)	0	3
1	Ac	244/246 (99%)	145 (59%)	59 (24%)	40 (16%)	0	3
1	Ad	244/246 (99%)	145 (59%)	59 (24%)	40 (16%)	0	3
1	Ae	244/246 (99%)	145 (59%)	59 (24%)	40 (16%)	0	3
1	Af	244/246 (99%)	145 (59%)	59 (24%)	40 (16%)	0	3
1	Ag	244/246 (99%)	145 (59%)	59 (24%)	40 (16%)	0	3
1	Ah	244/246 (99%)	145 (59%)	59 (24%)	40 (16%)	0	3
1	Ai	244/246 (99%)	145 (59%)	59 (24%)	40 (16%)	0	3
1	Aj	244/246 (99%)	145 (59%)	59 (24%)	40 (16%)	0	3

*Continued on next page...*

Continued from previous page...

Mol	Chain	Analysed	Favoured	Allowed	Outliers	Percentiles	
1	Ak	244/246 (99%)	145 (59%)	59 (24%)	40 (16%)	0	3
1	Al	244/246 (99%)	144 (59%)	60 (25%)	40 (16%)	0	3
1	Am	244/246 (99%)	145 (59%)	59 (24%)	40 (16%)	0	3
1	An	244/246 (99%)	144 (59%)	60 (25%)	40 (16%)	0	3
1	Ao	244/246 (99%)	144 (59%)	60 (25%)	40 (16%)	0	3
1	BA	244/246 (99%)	144 (59%)	60 (25%)	40 (16%)	0	3
1	BB	244/246 (99%)	145 (59%)	59 (24%)	40 (16%)	0	3
1	BC	244/246 (99%)	145 (59%)	59 (24%)	40 (16%)	0	3
1	BD	244/246 (99%)	145 (59%)	59 (24%)	40 (16%)	0	3
1	BE	244/246 (99%)	144 (59%)	60 (25%)	40 (16%)	0	3
1	BF	244/246 (99%)	145 (59%)	59 (24%)	40 (16%)	0	3
1	BG	244/246 (99%)	145 (59%)	59 (24%)	40 (16%)	0	3
1	BH	244/246 (99%)	145 (59%)	59 (24%)	40 (16%)	0	3
1	BI	244/246 (99%)	145 (59%)	59 (24%)	40 (16%)	0	3
2	C0	154/230 (67%)	104 (68%)	33 (21%)	17 (11%)	0	7
2	C1	154/230 (67%)	104 (68%)	33 (21%)	17 (11%)	0	7
2	C2	154/230 (67%)	104 (68%)	33 (21%)	17 (11%)	0	7
2	C3	154/230 (67%)	104 (68%)	33 (21%)	17 (11%)	0	7
2	C4	154/230 (67%)	104 (68%)	33 (21%)	17 (11%)	0	7
2	C5	154/230 (67%)	104 (68%)	33 (21%)	17 (11%)	0	7
2	C6	154/230 (67%)	104 (68%)	33 (21%)	17 (11%)	0	7
2	C7	154/230 (67%)	104 (68%)	33 (21%)	17 (11%)	0	7
2	C8	154/230 (67%)	104 (68%)	33 (21%)	17 (11%)	0	7
2	C9	154/230 (67%)	104 (68%)	33 (21%)	17 (11%)	0	7
2	CA	154/230 (67%)	104 (68%)	33 (21%)	17 (11%)	0	7
2	CB	154/230 (67%)	104 (68%)	33 (21%)	17 (11%)	0	7
2	CC	154/230 (67%)	104 (68%)	33 (21%)	17 (11%)	0	7
2	CD	154/230 (67%)	104 (68%)	33 (21%)	17 (11%)	0	7
2	CE	154/230 (67%)	104 (68%)	33 (21%)	17 (11%)	0	7
2	CF	154/230 (67%)	104 (68%)	33 (21%)	17 (11%)	0	7
2	CG	154/230 (67%)	104 (68%)	33 (21%)	17 (11%)	0	7

Continued on next page...

*Continued from previous page...*

Mol	Chain	Analysed	Favoured	Allowed	Outliers	Percentiles	
2	CH	154/230 (67%)	104 (68%)	33 (21%)	17 (11%)	0	7
2	CI	154/230 (67%)	104 (68%)	33 (21%)	17 (11%)	0	7
2	CJ	154/230 (67%)	104 (68%)	33 (21%)	17 (11%)	0	7
2	CK	154/230 (67%)	104 (68%)	33 (21%)	17 (11%)	0	7
2	CL	154/230 (67%)	104 (68%)	33 (21%)	17 (11%)	0	7
2	CM	154/230 (67%)	104 (68%)	33 (21%)	17 (11%)	0	7
2	CN	154/230 (67%)	104 (68%)	33 (21%)	17 (11%)	0	7
2	CO	154/230 (67%)	104 (68%)	33 (21%)	17 (11%)	0	7
2	CP	154/230 (67%)	104 (68%)	33 (21%)	17 (11%)	0	7
2	CQ	154/230 (67%)	104 (68%)	33 (21%)	17 (11%)	0	7
2	CR	154/230 (67%)	104 (68%)	33 (21%)	17 (11%)	0	7
2	CS	154/230 (67%)	104 (68%)	33 (21%)	17 (11%)	0	7
2	CT	154/230 (67%)	104 (68%)	33 (21%)	17 (11%)	0	7
2	CU	154/230 (67%)	104 (68%)	33 (21%)	17 (11%)	0	7
2	CV	154/230 (67%)	104 (68%)	33 (21%)	17 (11%)	0	7
2	CW	154/230 (67%)	104 (68%)	33 (21%)	17 (11%)	0	7
2	CX	154/230 (67%)	104 (68%)	33 (21%)	17 (11%)	0	7
2	CY	154/230 (67%)	104 (68%)	33 (21%)	17 (11%)	0	7
2	CZ	154/230 (67%)	104 (68%)	33 (21%)	17 (11%)	0	7
2	Ca	154/230 (67%)	104 (68%)	33 (21%)	17 (11%)	0	7
2	Cb	154/230 (67%)	104 (68%)	33 (21%)	17 (11%)	0	7
2	Cc	154/230 (67%)	104 (68%)	33 (21%)	17 (11%)	0	7
2	Cd	154/230 (67%)	104 (68%)	33 (21%)	17 (11%)	0	7
2	Ce	154/230 (67%)	104 (68%)	33 (21%)	17 (11%)	0	7
2	Cf	154/230 (67%)	104 (68%)	33 (21%)	17 (11%)	0	7
2	Cg	154/230 (67%)	104 (68%)	33 (21%)	17 (11%)	0	7
2	Ch	154/230 (67%)	104 (68%)	33 (21%)	17 (11%)	0	7
2	Ci	154/230 (67%)	104 (68%)	33 (21%)	17 (11%)	0	7
2	Cj	154/230 (67%)	104 (68%)	33 (21%)	17 (11%)	0	7
2	Ck	154/230 (67%)	104 (68%)	33 (21%)	17 (11%)	0	7
2	Cl	154/230 (67%)	104 (68%)	33 (21%)	17 (11%)	0	7

*Continued on next page...*



*Continued from previous page...*

Mol	Chain	Analysed	Favoured	Allowed	Outliers	Percentiles	
2	Cm	154/230 (67%)	104 (68%)	33 (21%)	17 (11%)	0	7
2	Cn	154/230 (67%)	104 (68%)	33 (21%)	17 (11%)	0	7
2	Co	154/230 (67%)	104 (68%)	33 (21%)	17 (11%)	0	7
2	Cp	154/230 (67%)	104 (68%)	33 (21%)	17 (11%)	0	7
2	Cq	154/230 (67%)	104 (68%)	33 (21%)	17 (11%)	0	7
2	Cr	154/230 (67%)	104 (68%)	33 (21%)	17 (11%)	0	7
2	Cs	154/230 (67%)	104 (68%)	33 (21%)	17 (11%)	0	7
2	Ct	154/230 (67%)	104 (68%)	33 (21%)	17 (11%)	0	7
2	Cu	154/230 (67%)	104 (68%)	33 (21%)	17 (11%)	0	7
2	Cv	154/230 (67%)	104 (68%)	33 (21%)	17 (11%)	0	7
2	Cw	154/230 (67%)	104 (68%)	33 (21%)	17 (11%)	0	7
2	Cx	154/230 (67%)	104 (68%)	33 (21%)	17 (11%)	0	7
3	D0	224/226 (99%)	155 (69%)	46 (20%)	23 (10%)	0	8
3	D1	224/226 (99%)	156 (70%)	45 (20%)	23 (10%)	0	8
3	D2	224/226 (99%)	155 (69%)	46 (20%)	23 (10%)	0	8
3	D3	224/226 (99%)	156 (70%)	45 (20%)	23 (10%)	0	8
3	D4	224/226 (99%)	155 (69%)	46 (20%)	23 (10%)	0	8
3	D5	224/226 (99%)	156 (70%)	45 (20%)	23 (10%)	0	8
3	D6	224/226 (99%)	156 (70%)	45 (20%)	23 (10%)	0	8
3	D7	224/226 (99%)	156 (70%)	45 (20%)	23 (10%)	0	8
3	D8	224/226 (99%)	156 (70%)	45 (20%)	23 (10%)	0	8
3	D9	224/226 (99%)	155 (69%)	46 (20%)	23 (10%)	0	8
3	DA	224/226 (99%)	155 (69%)	46 (20%)	23 (10%)	0	8
3	DB	224/226 (99%)	156 (70%)	45 (20%)	23 (10%)	0	8
3	DC	224/226 (99%)	156 (70%)	45 (20%)	23 (10%)	0	8
3	DD	224/226 (99%)	156 (70%)	45 (20%)	23 (10%)	0	8
3	DE	224/226 (99%)	155 (69%)	46 (20%)	23 (10%)	0	8
3	DF	224/226 (99%)	155 (69%)	46 (20%)	23 (10%)	0	8
3	DG	224/226 (99%)	155 (69%)	46 (20%)	23 (10%)	0	8
3	DH	224/226 (99%)	156 (70%)	45 (20%)	23 (10%)	0	8
3	DI	224/226 (99%)	156 (70%)	45 (20%)	23 (10%)	0	8

*Continued on next page...*

*Continued from previous page...*

Mol	Chain	Analysed	Favoured	Allowed	Outliers	Percentiles	
3	DJ	224/226 (99%)	156 (70%)	45 (20%)	23 (10%)	0	8
3	DK	224/226 (99%)	155 (69%)	46 (20%)	23 (10%)	0	8
3	DL	224/226 (99%)	156 (70%)	45 (20%)	23 (10%)	0	8
3	DM	224/226 (99%)	156 (70%)	45 (20%)	23 (10%)	0	8
3	DN	224/226 (99%)	155 (69%)	46 (20%)	23 (10%)	0	8
3	DO	224/226 (99%)	156 (70%)	45 (20%)	23 (10%)	0	8
3	DP	224/226 (99%)	156 (70%)	45 (20%)	23 (10%)	0	8
3	DQ	224/226 (99%)	155 (69%)	46 (20%)	23 (10%)	0	8
3	DR	224/226 (99%)	155 (69%)	46 (20%)	23 (10%)	0	8
3	DS	224/226 (99%)	155 (69%)	46 (20%)	23 (10%)	0	8
3	DT	224/226 (99%)	156 (70%)	45 (20%)	23 (10%)	0	8
3	DU	224/226 (99%)	155 (69%)	46 (20%)	23 (10%)	0	8
3	DV	224/226 (99%)	156 (70%)	45 (20%)	23 (10%)	0	8
3	DW	224/226 (99%)	156 (70%)	45 (20%)	23 (10%)	0	8
3	DX	224/226 (99%)	155 (69%)	46 (20%)	23 (10%)	0	8
3	DY	224/226 (99%)	156 (70%)	45 (20%)	23 (10%)	0	8
3	DZ	224/226 (99%)	156 (70%)	45 (20%)	23 (10%)	0	8
3	Da	224/226 (99%)	156 (70%)	45 (20%)	23 (10%)	0	8
3	Db	224/226 (99%)	156 (70%)	45 (20%)	23 (10%)	0	8
3	Dc	224/226 (99%)	155 (69%)	46 (20%)	23 (10%)	0	8
3	Dd	224/226 (99%)	156 (70%)	45 (20%)	23 (10%)	0	8
3	De	224/226 (99%)	155 (69%)	46 (20%)	23 (10%)	0	8
3	Df	224/226 (99%)	156 (70%)	45 (20%)	23 (10%)	0	8
3	Dg	224/226 (99%)	156 (70%)	45 (20%)	23 (10%)	0	8
3	Dh	224/226 (99%)	155 (69%)	46 (20%)	23 (10%)	0	8
3	Di	224/226 (99%)	155 (69%)	46 (20%)	23 (10%)	0	8
3	Dj	224/226 (99%)	156 (70%)	45 (20%)	23 (10%)	0	8
3	Dk	224/226 (99%)	155 (69%)	46 (20%)	23 (10%)	0	8
3	Dl	224/226 (99%)	155 (69%)	46 (20%)	23 (10%)	0	8
3	Dm	224/226 (99%)	156 (70%)	45 (20%)	23 (10%)	0	8
3	Dn	224/226 (99%)	155 (69%)	46 (20%)	23 (10%)	0	8

*Continued on next page...*

Continued from previous page...

Mol	Chain	Analysed	Favoured	Allowed	Outliers	Percentiles	
3	Do	224/226 (99%)	155 (69%)	46 (20%)	23 (10%)	0	8
3	Dp	224/226 (99%)	156 (70%)	45 (20%)	23 (10%)	0	8
3	Dq	224/226 (99%)	156 (70%)	45 (20%)	23 (10%)	0	8
3	Dr	224/226 (99%)	155 (69%)	46 (20%)	23 (10%)	0	8
3	Ds	224/226 (99%)	156 (70%)	45 (20%)	23 (10%)	0	8
3	EA	224/226 (99%)	156 (70%)	45 (20%)	23 (10%)	0	8
3	EB	224/226 (99%)	155 (69%)	46 (20%)	23 (10%)	0	8
3	EC	224/226 (99%)	155 (69%)	46 (20%)	23 (10%)	0	8
3	ED	224/226 (99%)	156 (70%)	45 (20%)	23 (10%)	0	8
3	EE	224/226 (99%)	155 (69%)	46 (20%)	23 (10%)	0	8
4	F0	20/80 (25%)	9 (45%)	7 (35%)	4 (20%)	0	2
4	F1	20/80 (25%)	9 (45%)	7 (35%)	4 (20%)	0	2
4	F2	20/80 (25%)	9 (45%)	7 (35%)	4 (20%)	0	2
4	F3	20/80 (25%)	9 (45%)	7 (35%)	4 (20%)	0	2
4	F4	20/80 (25%)	9 (45%)	7 (35%)	4 (20%)	0	2
4	F5	20/80 (25%)	9 (45%)	7 (35%)	4 (20%)	0	2
4	F6	20/80 (25%)	9 (45%)	7 (35%)	4 (20%)	0	2
4	F7	20/80 (25%)	9 (45%)	7 (35%)	4 (20%)	0	2
4	F8	20/80 (25%)	9 (45%)	7 (35%)	4 (20%)	0	2
4	F9	20/80 (25%)	9 (45%)	7 (35%)	4 (20%)	0	2
4	FA	20/80 (25%)	9 (45%)	7 (35%)	4 (20%)	0	2
4	FB	20/80 (25%)	9 (45%)	7 (35%)	4 (20%)	0	2
4	FC	20/80 (25%)	9 (45%)	7 (35%)	4 (20%)	0	2
4	FD	20/80 (25%)	9 (45%)	7 (35%)	4 (20%)	0	2
4	FE	20/80 (25%)	9 (45%)	7 (35%)	4 (20%)	0	2
4	FF	20/80 (25%)	9 (45%)	7 (35%)	4 (20%)	0	2
4	FG	20/80 (25%)	9 (45%)	7 (35%)	4 (20%)	0	2
4	FH	20/80 (25%)	9 (45%)	7 (35%)	4 (20%)	0	2
4	FI	20/80 (25%)	9 (45%)	7 (35%)	4 (20%)	0	2
4	FJ	20/80 (25%)	9 (45%)	7 (35%)	4 (20%)	0	2
4	FK	20/80 (25%)	9 (45%)	7 (35%)	4 (20%)	0	2

Continued on next page...

*Continued from previous page...*

Mol	Chain	Analysed	Favoured	Allowed	Outliers	Percentiles	
4	FL	20/80 (25%)	9 (45%)	7 (35%)	4 (20%)	0	2
4	FM	20/80 (25%)	9 (45%)	7 (35%)	4 (20%)	0	2
4	FN	20/80 (25%)	9 (45%)	7 (35%)	4 (20%)	0	2
4	FO	20/80 (25%)	9 (45%)	7 (35%)	4 (20%)	0	2
4	FP	20/80 (25%)	9 (45%)	7 (35%)	4 (20%)	0	2
4	FQ	20/80 (25%)	9 (45%)	7 (35%)	4 (20%)	0	2
4	FR	20/80 (25%)	9 (45%)	7 (35%)	4 (20%)	0	2
4	FS	20/80 (25%)	9 (45%)	7 (35%)	4 (20%)	0	2
4	FT	20/80 (25%)	9 (45%)	7 (35%)	4 (20%)	0	2
4	FU	20/80 (25%)	9 (45%)	7 (35%)	4 (20%)	0	2
4	FV	20/80 (25%)	9 (45%)	7 (35%)	4 (20%)	0	2
4	FW	20/80 (25%)	9 (45%)	7 (35%)	4 (20%)	0	2
4	FX	20/80 (25%)	9 (45%)	7 (35%)	4 (20%)	0	2
4	FY	20/80 (25%)	9 (45%)	7 (35%)	4 (20%)	0	2
4	FZ	20/80 (25%)	9 (45%)	7 (35%)	4 (20%)	0	2
4	Fa	20/80 (25%)	9 (45%)	7 (35%)	4 (20%)	0	2
4	Fb	20/80 (25%)	9 (45%)	7 (35%)	4 (20%)	0	2
4	Fc	20/80 (25%)	9 (45%)	7 (35%)	4 (20%)	0	2
4	Fd	20/80 (25%)	9 (45%)	7 (35%)	4 (20%)	0	2
4	Fe	20/80 (25%)	9 (45%)	7 (35%)	4 (20%)	0	2
4	Ff	20/80 (25%)	9 (45%)	7 (35%)	4 (20%)	0	2
4	Fg	20/80 (25%)	9 (45%)	7 (35%)	4 (20%)	0	2
4	Fh	20/80 (25%)	9 (45%)	7 (35%)	4 (20%)	0	2
4	Fi	20/80 (25%)	9 (45%)	7 (35%)	4 (20%)	0	2
4	Fj	20/80 (25%)	9 (45%)	7 (35%)	4 (20%)	0	2
4	Fk	20/80 (25%)	9 (45%)	7 (35%)	4 (20%)	0	2
4	Fl	20/80 (25%)	9 (45%)	7 (35%)	4 (20%)	0	2
4	Fm	20/80 (25%)	9 (45%)	7 (35%)	4 (20%)	0	2
4	Fn	20/80 (25%)	9 (45%)	7 (35%)	4 (20%)	0	2
4	Fo	20/80 (25%)	9 (45%)	7 (35%)	4 (20%)	0	2
4	Fp	20/80 (25%)	9 (45%)	7 (35%)	4 (20%)	0	2

*Continued on next page...*

Continued from previous page...

Mol	Chain	Analysed	Favoured	Allowed	Outliers	Percentiles	
4	Fq	20/80 (25%)	9 (45%)	7 (35%)	4 (20%)	0	2
4	Fr	20/80 (25%)	9 (45%)	7 (35%)	4 (20%)	0	2
4	Fs	20/80 (25%)	9 (45%)	7 (35%)	4 (20%)	0	2
4	Ft	20/80 (25%)	9 (45%)	7 (35%)	4 (20%)	0	2
4	Fu	20/80 (25%)	9 (45%)	7 (35%)	4 (20%)	0	2
4	Fv	20/80 (25%)	9 (45%)	7 (35%)	4 (20%)	0	2
4	Fw	20/80 (25%)	9 (45%)	7 (35%)	4 (20%)	0	2
4	Fx	20/80 (25%)	9 (45%)	7 (35%)	4 (20%)	0	2
All	All	38520/46920 (82%)	24801 (64%)	8679 (22%)	5040 (13%)	1	5

5 of 5040 Ramachandran outliers are listed below:

Mol	Chain	Res	Type
1	A0	10	PRO
1	A0	18	ALA
1	A0	22	VAL
1	A0	26	VAL
1	A0	63	THR

### 5.3.2 Protein sidechains [i](#)

In the following table, the Percentiles column shows the percent sidechain outliers of the chain as a percentile score with respect to all PDB entries followed by that with respect to all EM entries.

The Analysed column shows the number of residues for which the sidechain conformation was analysed, and the total number of residues.

Mol	Chain	Analysed	Rotameric	Outliers	Percentiles	
1	A0	208/208 (100%)	174 (84%)	34 (16%)	2	13
1	A1	208/208 (100%)	174 (84%)	34 (16%)	2	13
1	A2	208/208 (100%)	174 (84%)	34 (16%)	2	13
1	A3	208/208 (100%)	174 (84%)	34 (16%)	2	13
1	A4	208/208 (100%)	174 (84%)	34 (16%)	2	13
1	A5	208/208 (100%)	174 (84%)	34 (16%)	2	13
1	A6	208/208 (100%)	174 (84%)	34 (16%)	2	13
1	A7	208/208 (100%)	174 (84%)	34 (16%)	2	13

Continued on next page...

*Continued from previous page...*

Mol	Chain	Analysed	Rotameric	Outliers	Percentiles	
1	A8	208/208 (100%)	174 (84%)	34 (16%)	2	13
1	A9	208/208 (100%)	174 (84%)	34 (16%)	2	13
1	AA	208/208 (100%)	174 (84%)	34 (16%)	2	13
1	AB	208/208 (100%)	174 (84%)	34 (16%)	2	13
1	AC	208/208 (100%)	174 (84%)	34 (16%)	2	13
1	AD	208/208 (100%)	174 (84%)	34 (16%)	2	13
1	AE	208/208 (100%)	174 (84%)	34 (16%)	2	13
1	AF	208/208 (100%)	174 (84%)	34 (16%)	2	13
1	AG	208/208 (100%)	174 (84%)	34 (16%)	2	13
1	AH	208/208 (100%)	174 (84%)	34 (16%)	2	13
1	AI	208/208 (100%)	173 (83%)	35 (17%)	2	12
1	AJ	208/208 (100%)	174 (84%)	34 (16%)	2	13
1	AK	208/208 (100%)	174 (84%)	34 (16%)	2	13
1	AL	208/208 (100%)	174 (84%)	34 (16%)	2	13
1	AM	208/208 (100%)	174 (84%)	34 (16%)	2	13
1	AN	208/208 (100%)	174 (84%)	34 (16%)	2	13
1	AO	208/208 (100%)	174 (84%)	34 (16%)	2	13
1	AP	208/208 (100%)	174 (84%)	34 (16%)	2	13
1	AQ	208/208 (100%)	174 (84%)	34 (16%)	2	13
1	AR	208/208 (100%)	174 (84%)	34 (16%)	2	13
1	AS	208/208 (100%)	174 (84%)	34 (16%)	2	13
1	AT	208/208 (100%)	174 (84%)	34 (16%)	2	13
1	AU	208/208 (100%)	174 (84%)	34 (16%)	2	13
1	AV	208/208 (100%)	174 (84%)	34 (16%)	2	13
1	AW	208/208 (100%)	174 (84%)	34 (16%)	2	13
1	AX	208/208 (100%)	174 (84%)	34 (16%)	2	13
1	AY	208/208 (100%)	174 (84%)	34 (16%)	2	13
1	AZ	208/208 (100%)	174 (84%)	34 (16%)	2	13
1	Aa	208/208 (100%)	174 (84%)	34 (16%)	2	13
1	Ab	208/208 (100%)	174 (84%)	34 (16%)	2	13
1	Ac	208/208 (100%)	174 (84%)	34 (16%)	2	13

*Continued on next page...*

*Continued from previous page...*

Mol	Chain	Analysed	Rotameric	Outliers	Percentiles	
1	Ad	208/208 (100%)	174 (84%)	34 (16%)	2	13
1	Ae	208/208 (100%)	174 (84%)	34 (16%)	2	13
1	Af	208/208 (100%)	174 (84%)	34 (16%)	2	13
1	Ag	208/208 (100%)	174 (84%)	34 (16%)	2	13
1	Ah	208/208 (100%)	173 (83%)	35 (17%)	2	12
1	Ai	208/208 (100%)	174 (84%)	34 (16%)	2	13
1	Aj	208/208 (100%)	174 (84%)	34 (16%)	2	13
1	Ak	208/208 (100%)	174 (84%)	34 (16%)	2	13
1	Al	208/208 (100%)	174 (84%)	34 (16%)	2	13
1	Am	208/208 (100%)	174 (84%)	34 (16%)	2	13
1	An	208/208 (100%)	174 (84%)	34 (16%)	2	13
1	Ao	208/208 (100%)	174 (84%)	34 (16%)	2	13
1	BA	208/208 (100%)	174 (84%)	34 (16%)	2	13
1	BB	208/208 (100%)	174 (84%)	34 (16%)	2	13
1	BC	208/208 (100%)	174 (84%)	34 (16%)	2	13
1	BD	208/208 (100%)	174 (84%)	34 (16%)	2	13
1	BE	208/208 (100%)	174 (84%)	34 (16%)	2	13
1	BF	208/208 (100%)	174 (84%)	34 (16%)	2	13
1	BG	208/208 (100%)	174 (84%)	34 (16%)	2	13
1	BH	208/208 (100%)	174 (84%)	34 (16%)	2	13
1	BI	208/208 (100%)	174 (84%)	34 (16%)	2	13
2	C0	175/204 (86%)	132 (75%)	43 (25%)	0	3
2	C1	175/204 (86%)	133 (76%)	42 (24%)	0	4
2	C2	175/204 (86%)	133 (76%)	42 (24%)	0	4
2	C3	175/204 (86%)	133 (76%)	42 (24%)	0	4
2	C4	175/204 (86%)	133 (76%)	42 (24%)	0	4
2	C5	175/204 (86%)	132 (75%)	43 (25%)	0	3
2	C6	175/204 (86%)	133 (76%)	42 (24%)	0	4
2	C7	175/204 (86%)	133 (76%)	42 (24%)	0	4
2	C8	175/204 (86%)	133 (76%)	42 (24%)	0	4
2	C9	175/204 (86%)	133 (76%)	42 (24%)	0	4

*Continued on next page...*



*Continued from previous page...*

Mol	Chain	Analysed	Rotameric	Outliers	Percentiles	
2	CA	175/204 (86%)	133 (76%)	42 (24%)	0	4
2	CB	175/204 (86%)	133 (76%)	42 (24%)	0	4
2	CC	175/204 (86%)	132 (75%)	43 (25%)	0	3
2	CD	175/204 (86%)	132 (75%)	43 (25%)	0	3
2	CE	175/204 (86%)	133 (76%)	42 (24%)	0	4
2	CF	175/204 (86%)	132 (75%)	43 (25%)	0	3
2	CG	175/204 (86%)	132 (75%)	43 (25%)	0	3
2	CH	175/204 (86%)	133 (76%)	42 (24%)	0	4
2	CI	175/204 (86%)	132 (75%)	43 (25%)	0	3
2	CJ	175/204 (86%)	133 (76%)	42 (24%)	0	4
2	CK	175/204 (86%)	133 (76%)	42 (24%)	0	4
2	CL	175/204 (86%)	133 (76%)	42 (24%)	0	4
2	CM	175/204 (86%)	132 (75%)	43 (25%)	0	3
2	CN	175/204 (86%)	132 (75%)	43 (25%)	0	3
2	CO	175/204 (86%)	133 (76%)	42 (24%)	0	4
2	CP	175/204 (86%)	132 (75%)	43 (25%)	0	3
2	CQ	175/204 (86%)	132 (75%)	43 (25%)	0	3
2	CR	175/204 (86%)	133 (76%)	42 (24%)	0	4
2	CS	175/204 (86%)	133 (76%)	42 (24%)	0	4
2	CT	175/204 (86%)	133 (76%)	42 (24%)	0	4
2	CU	175/204 (86%)	132 (75%)	43 (25%)	0	3
2	CV	175/204 (86%)	133 (76%)	42 (24%)	0	4
2	CW	175/204 (86%)	132 (75%)	43 (25%)	0	3
2	CX	175/204 (86%)	133 (76%)	42 (24%)	0	4
2	CY	175/204 (86%)	132 (75%)	43 (25%)	0	3
2	CZ	175/204 (86%)	132 (75%)	43 (25%)	0	3
2	Ca	175/204 (86%)	133 (76%)	42 (24%)	0	4
2	Cb	175/204 (86%)	132 (75%)	43 (25%)	0	3
2	Cc	175/204 (86%)	132 (75%)	43 (25%)	0	3
2	Cd	175/204 (86%)	133 (76%)	42 (24%)	0	4
2	Ce	175/204 (86%)	132 (75%)	43 (25%)	0	3

*Continued on next page...*



*Continued from previous page...*

Mol	Chain	Analysed	Rotameric	Outliers	Percentiles	
2	Cf	175/204 (86%)	133 (76%)	42 (24%)	0	4
2	Cg	175/204 (86%)	133 (76%)	42 (24%)	0	4
2	Ch	175/204 (86%)	132 (75%)	43 (25%)	0	3
2	Ci	175/204 (86%)	133 (76%)	42 (24%)	0	4
2	Cj	175/204 (86%)	133 (76%)	42 (24%)	0	4
2	Ck	175/204 (86%)	133 (76%)	42 (24%)	0	4
2	Cl	175/204 (86%)	133 (76%)	42 (24%)	0	4
2	Cm	175/204 (86%)	132 (75%)	43 (25%)	0	3
2	Cn	175/204 (86%)	133 (76%)	42 (24%)	0	4
2	Co	175/204 (86%)	132 (75%)	43 (25%)	0	3
2	Cp	175/204 (86%)	132 (75%)	43 (25%)	0	3
2	Cq	175/204 (86%)	133 (76%)	42 (24%)	0	4
2	Cr	175/204 (86%)	133 (76%)	42 (24%)	0	4
2	Cs	175/204 (86%)	133 (76%)	42 (24%)	0	4
2	Ct	175/204 (86%)	132 (75%)	43 (25%)	0	3
2	Cu	175/204 (86%)	132 (75%)	43 (25%)	0	3
2	Cv	175/204 (86%)	133 (76%)	42 (24%)	0	4
2	Cw	175/204 (86%)	132 (75%)	43 (25%)	0	3
2	Cx	175/204 (86%)	133 (76%)	42 (24%)	0	4
3	D0	190/190 (100%)	146 (77%)	44 (23%)	1	4
3	D1	190/190 (100%)	147 (77%)	43 (23%)	1	5
3	D2	190/190 (100%)	146 (77%)	44 (23%)	1	4
3	D3	190/190 (100%)	146 (77%)	44 (23%)	1	4
3	D4	190/190 (100%)	146 (77%)	44 (23%)	1	4
3	D5	190/190 (100%)	146 (77%)	44 (23%)	1	4
3	D6	190/190 (100%)	146 (77%)	44 (23%)	1	4
3	D7	190/190 (100%)	146 (77%)	44 (23%)	1	4
3	D8	190/190 (100%)	146 (77%)	44 (23%)	1	4
3	D9	190/190 (100%)	147 (77%)	43 (23%)	1	5
3	DA	190/190 (100%)	146 (77%)	44 (23%)	1	4
3	DB	190/190 (100%)	146 (77%)	44 (23%)	1	4

*Continued on next page...*

*Continued from previous page...*

Mol	Chain	Analysed	Rotameric	Outliers	Percentiles	
3	DC	190/190 (100%)	146 (77%)	44 (23%)	1	4
3	DD	190/190 (100%)	147 (77%)	43 (23%)	1	5
3	DE	190/190 (100%)	146 (77%)	44 (23%)	1	4
3	DF	190/190 (100%)	146 (77%)	44 (23%)	1	4
3	DG	190/190 (100%)	146 (77%)	44 (23%)	1	4
3	DH	190/190 (100%)	146 (77%)	44 (23%)	1	4
3	DI	190/190 (100%)	146 (77%)	44 (23%)	1	4
3	DJ	190/190 (100%)	146 (77%)	44 (23%)	1	4
3	DK	190/190 (100%)	146 (77%)	44 (23%)	1	4
3	DL	190/190 (100%)	146 (77%)	44 (23%)	1	4
3	DM	190/190 (100%)	146 (77%)	44 (23%)	1	4
3	DN	190/190 (100%)	146 (77%)	44 (23%)	1	4
3	DO	190/190 (100%)	146 (77%)	44 (23%)	1	4
3	DP	190/190 (100%)	146 (77%)	44 (23%)	1	4
3	DQ	190/190 (100%)	146 (77%)	44 (23%)	1	4
3	DR	190/190 (100%)	147 (77%)	43 (23%)	1	5
3	DS	190/190 (100%)	146 (77%)	44 (23%)	1	4
3	DT	190/190 (100%)	146 (77%)	44 (23%)	1	4
3	DU	190/190 (100%)	146 (77%)	44 (23%)	1	4
3	DV	190/190 (100%)	146 (77%)	44 (23%)	1	4
3	DW	190/190 (100%)	146 (77%)	44 (23%)	1	4
3	DX	190/190 (100%)	146 (77%)	44 (23%)	1	4
3	DY	190/190 (100%)	146 (77%)	44 (23%)	1	4
3	DZ	190/190 (100%)	146 (77%)	44 (23%)	1	4
3	Da	190/190 (100%)	146 (77%)	44 (23%)	1	4
3	Db	190/190 (100%)	146 (77%)	44 (23%)	1	4
3	Dc	190/190 (100%)	146 (77%)	44 (23%)	1	4
3	Dd	190/190 (100%)	146 (77%)	44 (23%)	1	4
3	De	190/190 (100%)	146 (77%)	44 (23%)	1	4
3	Df	190/190 (100%)	146 (77%)	44 (23%)	1	4
3	Dg	190/190 (100%)	146 (77%)	44 (23%)	1	4

*Continued on next page...*

*Continued from previous page...*

Mol	Chain	Analysed	Rotameric	Outliers	Percentiles	
3	Dh	190/190 (100%)	146 (77%)	44 (23%)	1	4
3	Di	190/190 (100%)	146 (77%)	44 (23%)	1	4
3	Dj	190/190 (100%)	147 (77%)	43 (23%)	1	5
3	Dk	190/190 (100%)	146 (77%)	44 (23%)	1	4
3	DI	190/190 (100%)	146 (77%)	44 (23%)	1	4
3	Dm	190/190 (100%)	146 (77%)	44 (23%)	1	4
3	Dn	190/190 (100%)	146 (77%)	44 (23%)	1	4
3	Do	190/190 (100%)	146 (77%)	44 (23%)	1	4
3	Dp	190/190 (100%)	146 (77%)	44 (23%)	1	4
3	Dq	190/190 (100%)	147 (77%)	43 (23%)	1	5
3	Dr	190/190 (100%)	146 (77%)	44 (23%)	1	4
3	Ds	190/190 (100%)	146 (77%)	44 (23%)	1	4
3	EA	190/190 (100%)	146 (77%)	44 (23%)	1	4
3	EB	190/190 (100%)	146 (77%)	44 (23%)	1	4
3	EC	190/190 (100%)	146 (77%)	44 (23%)	1	4
3	ED	190/190 (100%)	146 (77%)	44 (23%)	1	4
3	EE	190/190 (100%)	146 (77%)	44 (23%)	1	4
4	F0	18/65 (28%)	13 (72%)	5 (28%)	0	3
4	F1	18/65 (28%)	13 (72%)	5 (28%)	0	3
4	F2	18/65 (28%)	13 (72%)	5 (28%)	0	3
4	F3	18/65 (28%)	13 (72%)	5 (28%)	0	3
4	F4	18/65 (28%)	13 (72%)	5 (28%)	0	3
4	F5	18/65 (28%)	13 (72%)	5 (28%)	0	3
4	F6	18/65 (28%)	13 (72%)	5 (28%)	0	3
4	F7	18/65 (28%)	13 (72%)	5 (28%)	0	3
4	F8	18/65 (28%)	13 (72%)	5 (28%)	0	3
4	F9	18/65 (28%)	13 (72%)	5 (28%)	0	3
4	FA	18/65 (28%)	13 (72%)	5 (28%)	0	3
4	FB	18/65 (28%)	13 (72%)	5 (28%)	0	3
4	FC	18/65 (28%)	13 (72%)	5 (28%)	0	3
4	FD	18/65 (28%)	13 (72%)	5 (28%)	0	3

*Continued on next page...*

*Continued from previous page...*

Mol	Chain	Analysed	Rotameric	Outliers	Percentiles	
4	FE	18/65 (28%)	13 (72%)	5 (28%)	0	3
4	FF	18/65 (28%)	13 (72%)	5 (28%)	0	3
4	FG	18/65 (28%)	13 (72%)	5 (28%)	0	3
4	FH	18/65 (28%)	13 (72%)	5 (28%)	0	3
4	FI	18/65 (28%)	13 (72%)	5 (28%)	0	3
4	FJ	18/65 (28%)	13 (72%)	5 (28%)	0	3
4	FK	18/65 (28%)	13 (72%)	5 (28%)	0	3
4	FL	18/65 (28%)	13 (72%)	5 (28%)	0	3
4	FM	18/65 (28%)	13 (72%)	5 (28%)	0	3
4	FN	18/65 (28%)	13 (72%)	5 (28%)	0	3
4	FO	18/65 (28%)	13 (72%)	5 (28%)	0	3
4	FP	18/65 (28%)	13 (72%)	5 (28%)	0	3
4	FQ	18/65 (28%)	13 (72%)	5 (28%)	0	3
4	FR	18/65 (28%)	13 (72%)	5 (28%)	0	3
4	FS	18/65 (28%)	13 (72%)	5 (28%)	0	3
4	FT	18/65 (28%)	13 (72%)	5 (28%)	0	3
4	FU	18/65 (28%)	13 (72%)	5 (28%)	0	3
4	FV	18/65 (28%)	13 (72%)	5 (28%)	0	3
4	FW	18/65 (28%)	13 (72%)	5 (28%)	0	3
4	FX	18/65 (28%)	13 (72%)	5 (28%)	0	3
4	FY	18/65 (28%)	13 (72%)	5 (28%)	0	3
4	FZ	18/65 (28%)	13 (72%)	5 (28%)	0	3
4	Fa	18/65 (28%)	13 (72%)	5 (28%)	0	3
4	Fb	18/65 (28%)	13 (72%)	5 (28%)	0	3
4	Fc	18/65 (28%)	13 (72%)	5 (28%)	0	3
4	Fd	18/65 (28%)	13 (72%)	5 (28%)	0	3
4	Fe	18/65 (28%)	13 (72%)	5 (28%)	0	3
4	Ff	18/65 (28%)	13 (72%)	5 (28%)	0	3
4	Fg	18/65 (28%)	13 (72%)	5 (28%)	0	3
4	Fh	18/65 (28%)	13 (72%)	5 (28%)	0	3
4	Fi	18/65 (28%)	13 (72%)	5 (28%)	0	3

*Continued on next page...*

Continued from previous page...

Mol	Chain	Analysed	Rotameric	Outliers	Percentiles	
4	Fj	18/65 (28%)	13 (72%)	5 (28%)	0	3
4	Fk	18/65 (28%)	13 (72%)	5 (28%)	0	3
4	Fl	18/65 (28%)	13 (72%)	5 (28%)	0	3
4	Fm	18/65 (28%)	13 (72%)	5 (28%)	0	3
4	Fn	18/65 (28%)	13 (72%)	5 (28%)	0	3
4	Fo	18/65 (28%)	13 (72%)	5 (28%)	0	3
4	Fp	18/65 (28%)	13 (72%)	5 (28%)	0	3
4	Fq	18/65 (28%)	13 (72%)	5 (28%)	0	3
4	Fr	18/65 (28%)	13 (72%)	5 (28%)	0	3
4	Fs	18/65 (28%)	13 (72%)	5 (28%)	0	3
4	Ft	18/65 (28%)	13 (72%)	5 (28%)	0	3
4	Fu	18/65 (28%)	13 (72%)	5 (28%)	0	3
4	Fv	18/65 (28%)	13 (72%)	5 (28%)	0	3
4	Fw	18/65 (28%)	13 (72%)	5 (28%)	0	3
4	Fx	18/65 (28%)	13 (72%)	5 (28%)	0	3
All	All	35460/40020 (89%)	27939 (79%)	7521 (21%)	3	6

5 of 7521 residues with a non-rotameric sidechain are listed below:

Mol	Chain	Res	Type
2	Cd	73	GLN
3	EC	26	TYR
2	Cx	214	SER
3	EA	76	MET
3	Df	54	CYS

Sometimes sidechains can be flipped to improve hydrogen bonding and reduce clashes. 5 of 1352 such sidechains are listed below:

Mol	Chain	Res	Type
3	DI	218	HIS
4	F4	23	GLN
3	DO	49	GLN
3	DI	178	ASN
3	Df	226	GLN

### 5.3.3 RNA [i](#)

There are no RNA molecules in this entry.

### 5.4 Non-standard residues in protein, DNA, RNA chains [i](#)

There are no non-standard protein/DNA/RNA residues in this entry.

### 5.5 Carbohydrates [i](#)

There are no monosaccharides in this entry.

### 5.6 Ligand geometry [i](#)

There are no ligands in this entry.

### 5.7 Other polymers [i](#)

There are no such residues in this entry.

### 5.8 Polymer linkage issues [i](#)

There are no chain breaks in this entry.

## 6 Map visualisation [i](#)

This section contains visualisations of the EMDB entry EMD-2389. These allow visual inspection of the internal detail of the map and identification of artifacts.

No raw map or half-maps were deposited for this entry and therefore no images, graphs, etc. pertaining to the raw map can be shown.

### 6.1 Orthogonal projections [i](#)

#### 6.1.1 Primary map

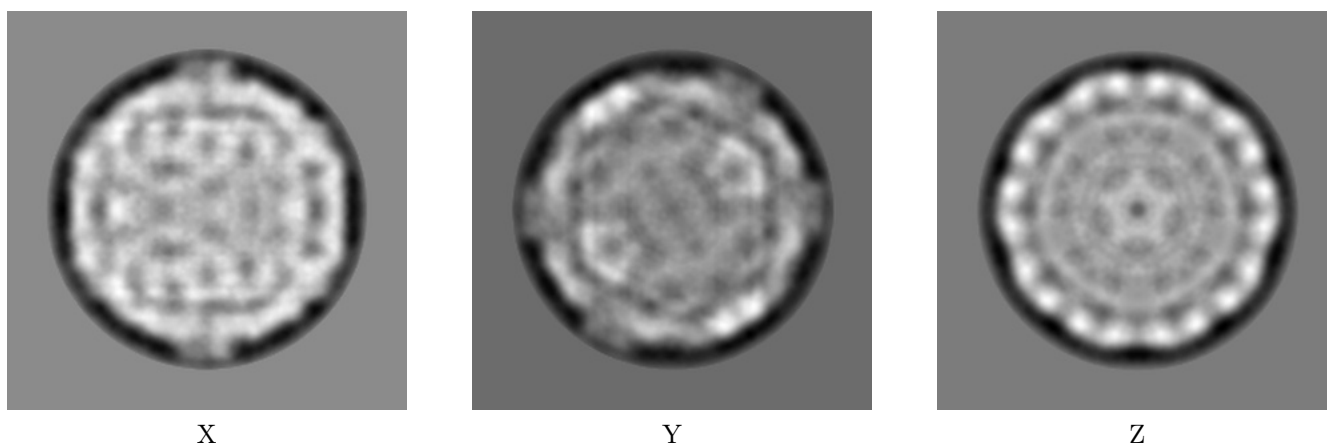

The images above show the map projected in three orthogonal directions.

### 6.2 Central slices [i](#)

#### 6.2.1 Primary map

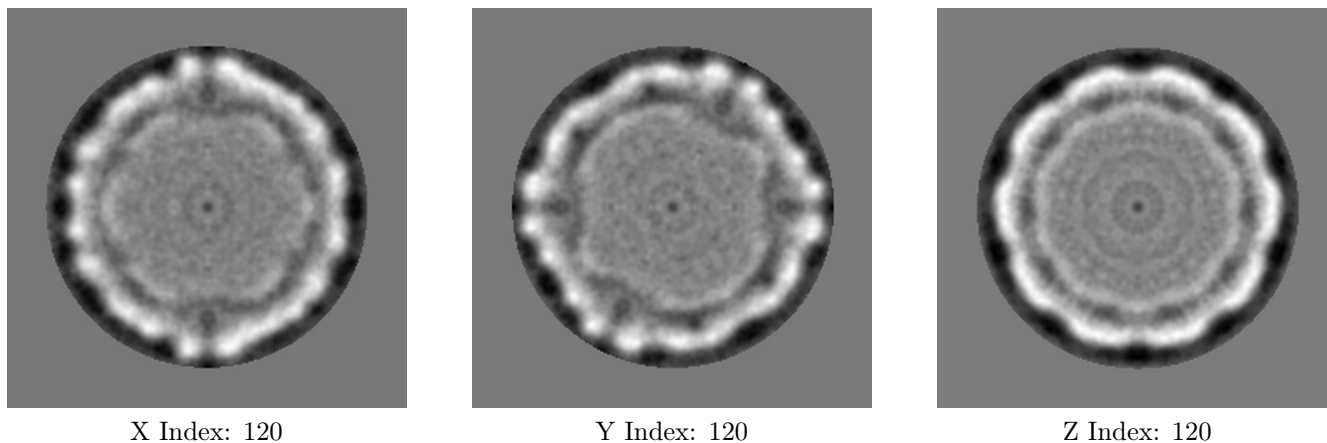

The images above show central slices of the map in three orthogonal directions.

## 6.3 Largest variance slices [i](#)

### 6.3.1 Primary map

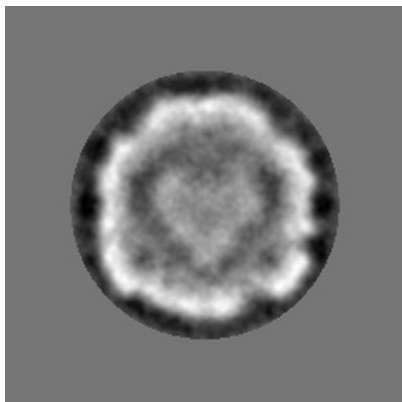

X Index: 173

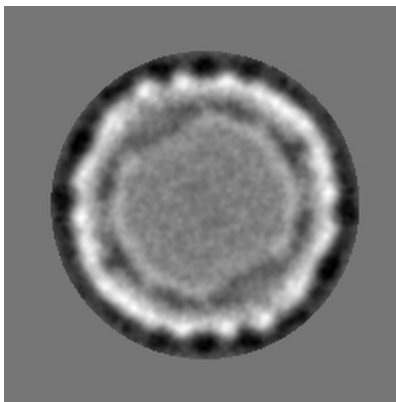

Y Index: 92

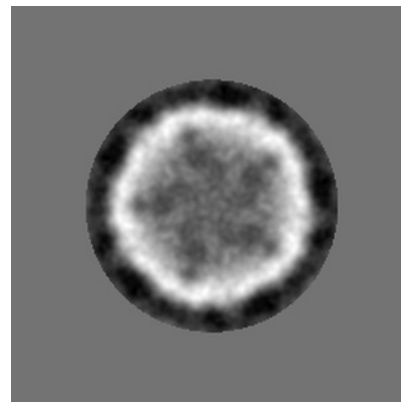

Z Index: 180

The images above show the largest variance slices of the map in three orthogonal directions.

## 6.4 Orthogonal surface views [i](#)

### 6.4.1 Primary map

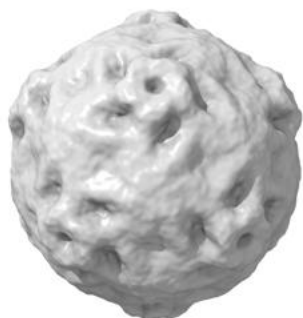

X

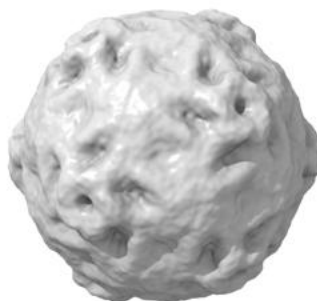

Y

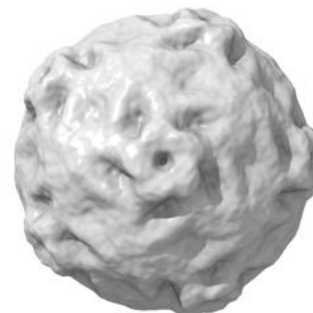

Z

The images above show the 3D surface view of the map at the recommended contour level 0.5. These images, in conjunction with the slice images, may facilitate assessment of whether an appropriate contour level has been provided.



## 6.5 Mask visualisation

This section was not generated. No masks/segmentation were deposited.

## 7 Map analysis [i](#)

This section contains the results of statistical analysis of the map.

### 7.1 Map-value distribution [i](#)

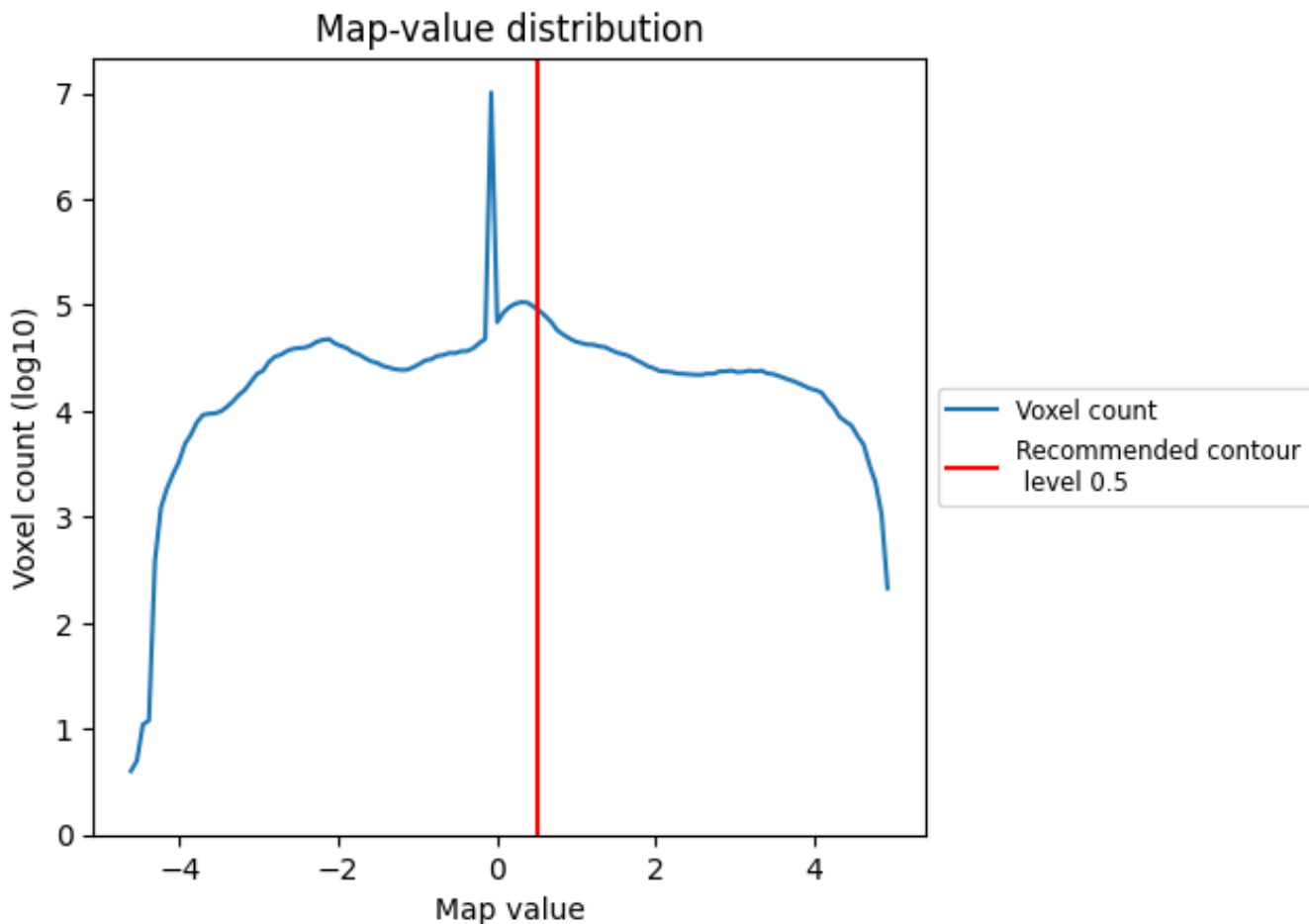

The map-value distribution is plotted in 128 intervals along the x-axis. The y-axis is logarithmic. A spike in this graph at zero usually indicates that the volume has been masked.

## 7.2 Volume estimate [i](#)

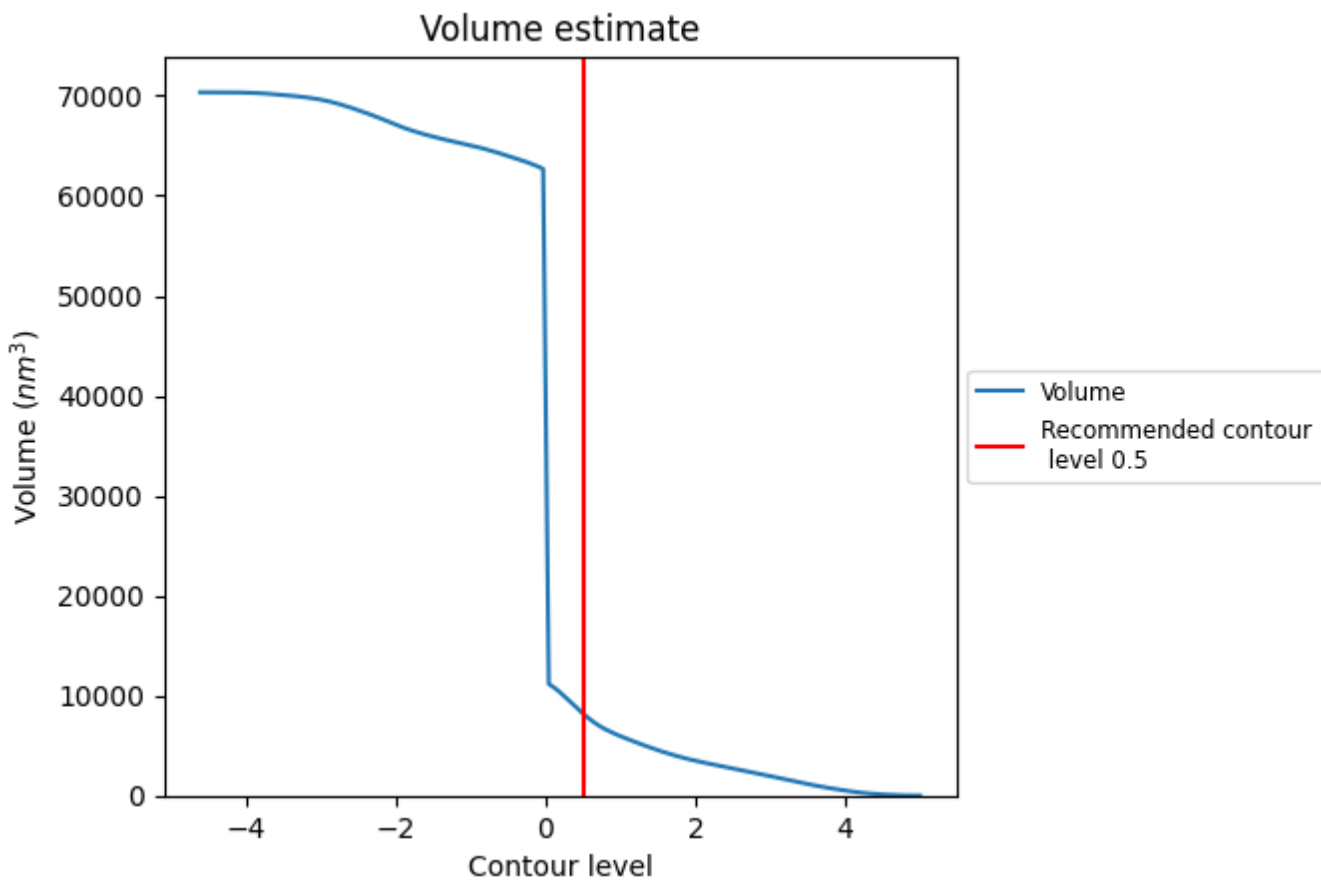

The volume at the recommended contour level is 8201 nm<sup>3</sup>; this corresponds to an approximate mass of 7408 kDa.

The volume estimate graph shows how the enclosed volume varies with the contour level. The recommended contour level is shown as a vertical line and the intersection between the line and the curve gives the volume of the enclosed surface at the given level.

### 7.3 Rotationally averaged power spectrum [i](#)

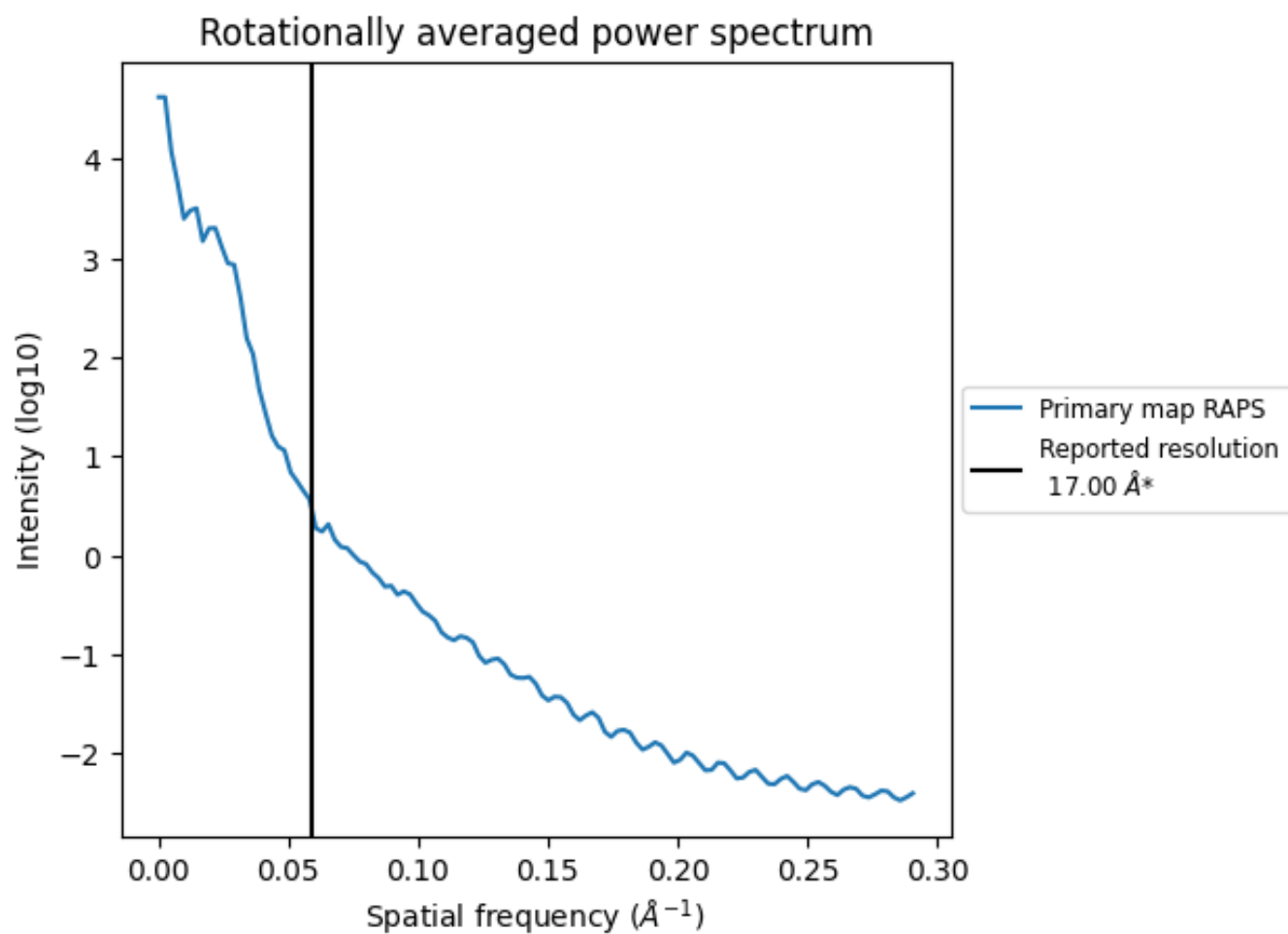

\*Reported resolution corresponds to spatial frequency of 0.059 Å<sup>-1</sup>

## 8 Fourier-Shell correlation

This section was not generated. No FSC curve or half-maps provided.

## 9 Map-model fit [i](#)

This section contains information regarding the fit between EMDB map EMD-2389 and PDB model 4CTF. Per-residue inclusion information can be found in section 3 on page 27.

### 9.1 Map-model overlay [i](#)



The images above show the 3D surface view of the map at the recommended contour level 0.5 at 50% transparency in yellow overlaid with a ribbon representation of the model coloured in blue. These images allow for the visual assessment of the quality of fit between the atomic model and the map.

## 9.2 Q-score mapped to coordinate model [i](#)

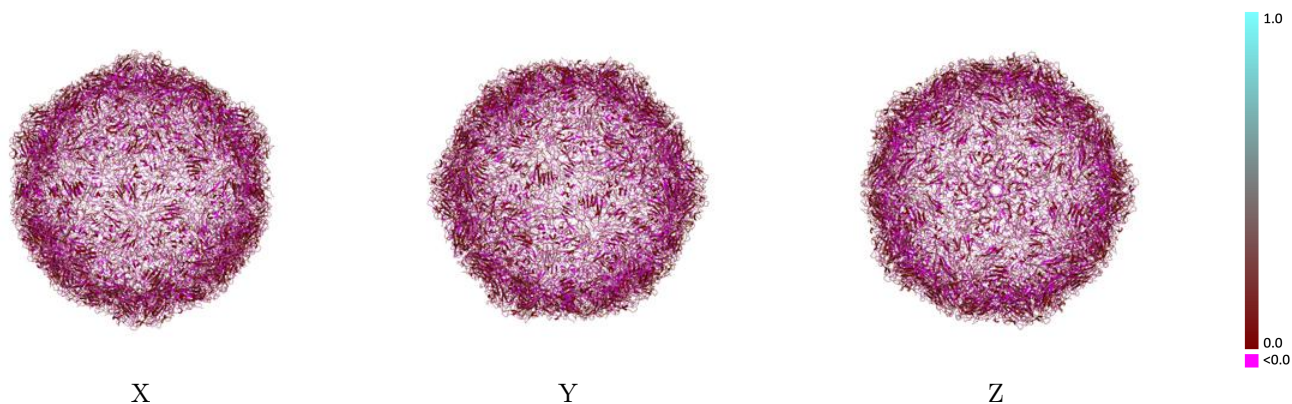

The images above show the model with each residue coloured according to its Q-score. This shows their resolvability in the map with higher Q-score values reflecting better resolvability. Please note: Q-score is calculating the resolvability of atoms, and thus high values are only expected at resolutions at which atoms can be resolved. Low Q-score values may therefore be expected for many entries.

## 9.3 Atom inclusion mapped to coordinate model [i](#)

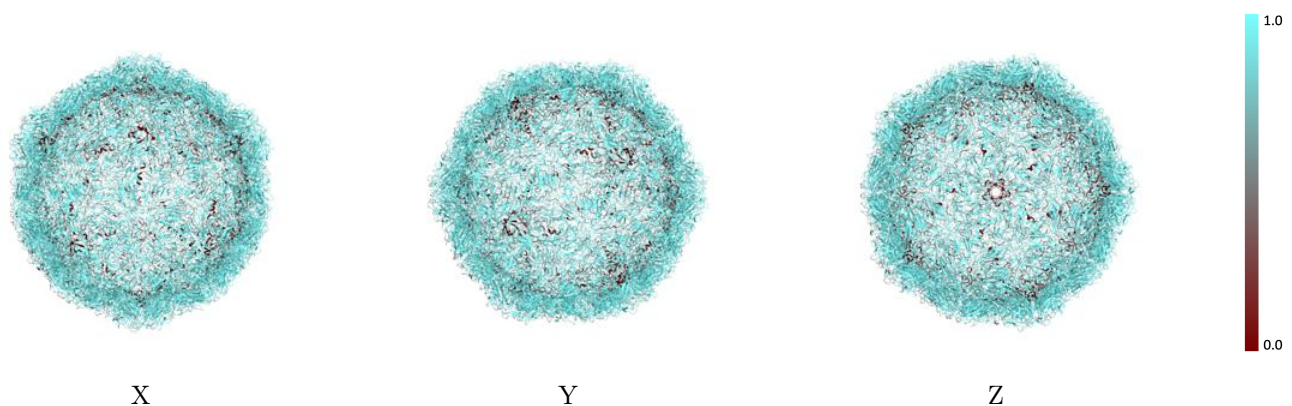

The images above show the model with each residue coloured according to its atom inclusion. This shows to what extent they are inside the map at the recommended contour level (0.5).

## 9.4 Atom inclusion [i](#)

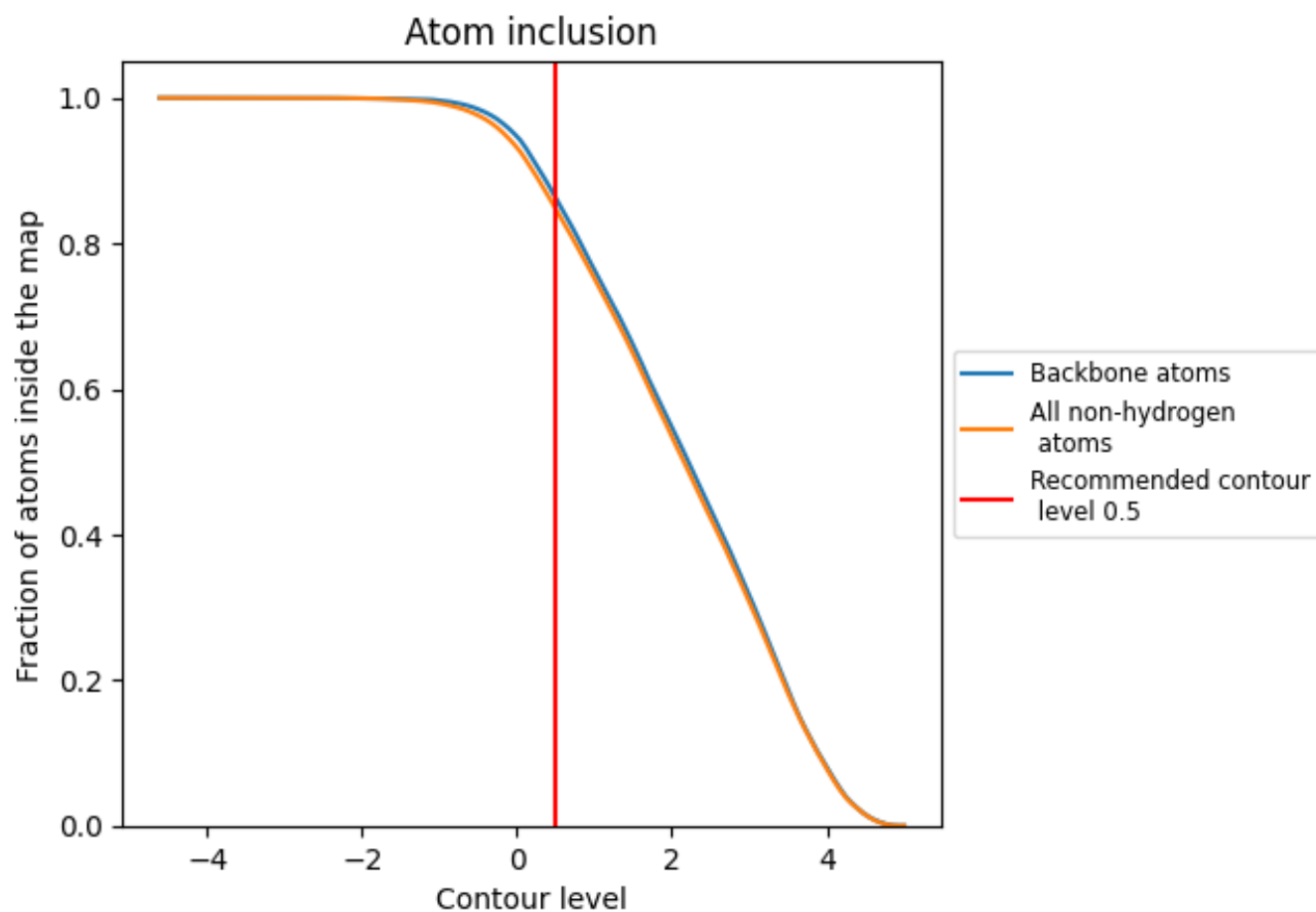







































































At the recommended contour level, 86% of all backbone atoms, 85% of all non-hydrogen atoms, are inside the map.



## 9.5 Map-model fit summary





















































































The table lists the average atom inclusion at the recommended contour level (0.5) and Q-score for the entire model and for each chain.

Chain	Atom inclusion	Q-score
All	 0.8474	 0.0420
A0	 0.8689	 0.0380
A1	 0.8837	 0.0400
A2	 0.8810	 0.0490
A3	 0.8747	 0.0440
A4	 0.8794	 0.0440
A5	 0.8704	 0.0450
A6	 0.8678	 0.0470
A7	 0.8699	 0.0480
A8	 0.8726	 0.0450
A9	 0.8609	 0.0430
AA	 0.8641	 0.0470
AB	 0.8657	 0.0490
AC	 0.8710	 0.0460
AD	 0.8720	 0.0450
AE	 0.8683	 0.0430
AF	 0.8667	 0.0490
AG	 0.8678	 0.0490
AH	 0.8731	 0.0480
AI	 0.8763	 0.0450
AJ	 0.8699	 0.0440
AK	 0.8752	 0.0370
AL	 0.8837	 0.0420
AM	 0.8757	 0.0460
AN	 0.8604	 0.0450
AO	 0.8572	 0.0400
AP	 0.8673	 0.0390
AQ	 0.8784	 0.0410
AR	 0.8773	 0.0430
AS	 0.8609	 0.0390
AT	 0.8789	 0.0430
AU	 0.8784	 0.0440
AV	 0.8710	 0.0480
AW	 0.8662	 0.0500
AX	 0.8715	 0.0490























































































*Continued on next page...*

*Continued from previous page...*

Chain	Atom inclusion	Q-score
AY	 0.8715	 0.0490
AZ	 0.8588	 0.0440
Aa	 0.8821	 0.0340
Ab	 0.8815	 0.0440
Ac	 0.8805	 0.0450
Ad	 0.8720	 0.0500
Ae	 0.8620	 0.0490
Af	 0.8736	 0.0450
Ag	 0.8884	 0.0370
Ah	 0.8657	 0.0440
Ai	 0.8815	 0.0370
Aj	 0.8863	 0.0400
Ak	 0.8773	 0.0430
Al	 0.8689	 0.0470
Am	 0.8630	 0.0430
An	 0.8673	 0.0390
Ao	 0.8636	 0.0420
BA	 0.8773	 0.0400
BB	 0.8879	 0.0400
BC	 0.8805	 0.0470
BD	 0.8652	 0.0460
BE	 0.8852	 0.0430
BF	 0.8773	 0.0510
BG	 0.8620	 0.0450
BH	 0.8715	 0.0420
BI	 0.8815	 0.0370
C0	 0.8871	 0.0510
C1	 0.8825	 0.0460
C2	 0.8766	 0.0390
C3	 0.8785	 0.0420
C4	 0.8620	 0.0260
C5	 0.8376	 0.0260
C6	 0.8337	 0.0250
C7	 0.8581	 0.0300
C8	 0.8746	 0.0310
C9	 0.8865	 0.0320
CA	 0.8356	 0.0320
CB	 0.8475	 0.0320
CC	 0.8416	 0.0280
CD	 0.8310	 0.0290
CE	 0.8251	 0.0340
CF	 0.8356	 0.0310





















































































*Continued on next page...*

*Continued from previous page...*

Chain	Atom inclusion	Q-score
CG	 0.8601	 0.0340
CH	 0.8568	 0.0330
CI	 0.8383	 0.0330
CJ	 0.8284	 0.0320
CK	 0.8818	 0.0350
CL	 0.8825	 0.0330
CM	 0.8865	 0.0420
CN	 0.8871	 0.0470
CO	 0.8838	 0.0440
CP	 0.8772	 0.0450
CQ	 0.8825	 0.0400
CR	 0.8838	 0.0400
CS	 0.8818	 0.0410
CT	 0.8818	 0.0480
CU	 0.8594	 0.0400
CV	 0.8376	 0.0390
CW	 0.8422	 0.0340
CX	 0.8726	 0.0380
CY	 0.8832	 0.0420
CZ	 0.8851	 0.0420
Ca	 0.8898	 0.0390
Cb	 0.8845	 0.0360
Cc	 0.8766	 0.0290
Cd	 0.8693	 0.0320
Ce	 0.8528	 0.0330
Cf	 0.8726	 0.0370
Cg	 0.8904	 0.0460
Ch	 0.8865	 0.0420
Ci	 0.8680	 0.0320
Cj	 0.8898	 0.0330
Ck	 0.8779	 0.0280
Cl	 0.8541	 0.0280
Cm	 0.8554	 0.0290
Cn	 0.8752	 0.0290
Co	 0.8891	 0.0440
Cp	 0.8832	 0.0400
Cq	 0.8640	 0.0370
Cr	 0.8733	 0.0370
Cs	 0.8851	 0.0360
Ct	 0.8607	 0.0320
Cu	 0.8779	 0.0300
Cv	 0.8871	 0.0350





















































































*Continued on next page...*

*Continued from previous page...*

Chain	Atom inclusion	Q-score
Cw	 0.8917	 0.0370
Cx	 0.8759	 0.0320
D0	 0.8956	 0.0580
D1	 0.8850	 0.0540
D2	 0.8749	 0.0520
D3	 0.8808	 0.0550
D4	 0.8661	 0.0450
D5	 0.8466	 0.0450
D6	 0.8360	 0.0380
D7	 0.8460	 0.0370
D8	 0.8673	 0.0440
D9	 0.8838	 0.0410
DA	 0.8354	 0.0400
DB	 0.8478	 0.0430
DC	 0.8501	 0.0450
DD	 0.8383	 0.0450
DE	 0.8301	 0.0420
DF	 0.8354	 0.0400
DG	 0.8519	 0.0470
DH	 0.8584	 0.0490
DI	 0.8519	 0.0500
DJ	 0.8348	 0.0460
DK	 0.8802	 0.0450
DL	 0.8814	 0.0420
DM	 0.8867	 0.0480
DN	 0.8897	 0.0480
DO	 0.8891	 0.0530
DP	 0.8844	 0.0460
DQ	 0.8826	 0.0490
DR	 0.8844	 0.0450
DS	 0.8885	 0.0460
DT	 0.8909	 0.0480
DU	 0.8631	 0.0580
DV	 0.8496	 0.0540
DW	 0.8389	 0.0460
DX	 0.8608	 0.0510
DY	 0.8773	 0.0570
DZ	 0.8861	 0.0540
Da	 0.8909	 0.0460
Db	 0.8879	 0.0470
Dc	 0.8767	 0.0430
Dd	 0.8743	 0.0440

*Continued on next page...*

*Continued from previous page...*

Chain	Atom inclusion	Q-score
De	 0.8608	 0.0500
Df	 0.8608	 0.0460
Dg	 0.8814	 0.0570
Dh	 0.8826	 0.0580
Di	 0.8743	 0.0510
Dj	 0.8873	 0.0460
Dk	 0.8808	 0.0450
Dl	 0.8661	 0.0470
Dm	 0.8608	 0.0440
Dn	 0.8667	 0.0400
Do	 0.8879	 0.0530
Dp	 0.8791	 0.0540
Dq	 0.8690	 0.0570
Dr	 0.8720	 0.0510
Ds	 0.8749	 0.0490
EA	 0.8690	 0.0480
EB	 0.8702	 0.0450
EC	 0.8814	 0.0460
ED	 0.8873	 0.0500
EE	 0.8773	 0.0470
F0	 0.2439	 0.0530
F1	 0.1829	 0.0540
F2	 0.1280	 0.0430
F3	 0.1463	 0.0410
F4	 0.0793	 0.0260
F5	 0.0732	 0.0130
F6	 0.0610	 0.0040
F7	 0.0976	 -0.0020
F8	 0.0915	 -0.0120
F9	 0.1707	 0.0090
FA	 0.0610	 0.0150
FB	 0.0671	 0.0140
FC	 0.0671	 0.0140
FD	 0.0549	 0.0250
FE	 0.0488	 0.0240
FF	 0.0671	 0.0040
FG	 0.0915	 0.0040
FH	 0.0732	 0.0240
FI	 0.0610	 0.0310
FJ	 0.0549	 0.0240
FK	 0.1768	 0.0400
FL	 0.1646	 0.0370

*Continued on next page...*

*Continued from previous page...*

Chain	Atom inclusion	Q-score
FM	0.1951	0.0380
FN	0.2439	0.0400
FO	0.2500	0.0560
FP	0.2134	0.0620
FQ	0.1707	0.0470
FR	0.2073	0.0390
FS	0.2500	0.0350
FT	0.2622	0.0450
FU	0.0854	0.0530
FV	0.0732	0.0130
FW	0.0793	0.0250
FX	0.1098	0.0150
FY	0.1037	0.0280
FZ	0.1890	0.0370
Fa	0.2195	0.0290
Fb	0.1890	0.0470
Fc	0.1280	0.0290
Fd	0.1341	0.0130
Fe	0.0976	0.0170
Ff	0.1220	0.0210
Fg	0.1524	0.0250
Fh	0.1402	0.0480
Fi	0.0915	0.0280
Fj	0.1341	0.0210
Fk	0.1159	0.0320
Fl	0.0976	0.0030
Fm	0.0976	0.0050
Fn	0.1585	0.0150
Fo	0.1951	0.0430
Fp	0.1341	0.0620
Fq	0.1098	0.0310
Fr	0.1159	0.0200
Fs	0.1646	0.0170
Ft	0.1098	0.0120
Fu	0.1098	0.0030
Fv	0.1646	0.0100
Fw	0.1524	0.0400
Fx	0.1159	0.0370