



# Full wwPDB X-ray Structure Validation Report ⓘ

May 21, 2020 – 07:45 am BST

PDB ID : 5D9A  
Title : Influenza C Virus RNA-dependent RNA Polymerase - Space group P212121  
Authors : Hengrung, N.; El Omari, K.; Serna Martin, I.; Vreede, F.T.; Cusack, S.;  
Rambo, R.P.; Vonrhein, C.; Bricogne, G.; Stuart, D.I.; Grimes, J.M.; Fodor,  
E.  
Deposited on : 2015-08-18  
Resolution : 4.30 Å(reported)

This is a Full wwPDB X-ray Structure Validation Report for a publicly released PDB entry.

We welcome your comments at [validation@mail.wwpdb.org](mailto:validation@mail.wwpdb.org)

A user guide is available at

<https://www.wwpdb.org/validation/2017/XrayValidationReportHelp>

with specific help available everywhere you see the ⓘ symbol.

---

The following versions of software and data (see [references ⓘ](#)) were used in the production of this report:

MolProbity : 4.02b-467  
Xtriage (Phenix) : 1.13  
EDS : 2.11  
Percentile statistics : 20191225.v01 (using entries in the PDB archive December 25th 2019)  
Refmac : 5.8.0158  
CCP4 : 7.0.044 (Gargrove)  
Ideal geometry (proteins) : Engh & Huber (2001)  
Ideal geometry (DNA, RNA) : Parkinson et al. (1996)  
Validation Pipeline (wwPDB-VP) : 2.11

# 1 Overall quality at a glance

The following experimental techniques were used to determine the structure:

*X-RAY DIFFRACTION*

The reported resolution of this entry is 4.30 Å.

Percentile scores (ranging between 0-100) for global validation metrics of the entry are shown in the following graphic. The table shows the number of entries on which the scores are based.

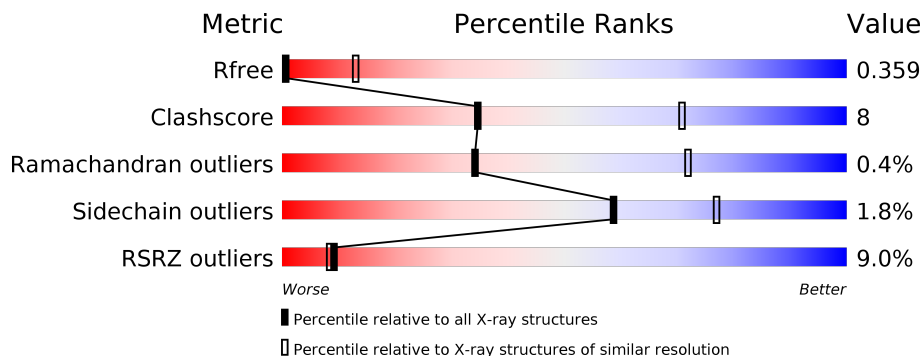

Metric	Whole archive (#Entries)	Similar resolution (#Entries, resolution range(Å))
$R_{free}$	130704	1014 (4.80-3.80)
Clashscore	141614	1077 (4.80-3.80)
Ramachandran outliers	138981	1029 (4.80-3.80)
Sidechain outliers	138945	1012 (4.80-3.80)
RSRZ outliers	127900	1075 (4.90-3.70)

The table below summarises the geometric issues observed across the polymeric chains and their fit to the electron density. The red, orange, yellow and green segments on the lower bar indicate the fraction of residues that contain outliers for  $\geq 3$ , 2, 1 and 0 types of geometric quality criteria respectively. A grey segment represents the fraction of residues that are not modelled. The numeric value for each fraction is indicated below the corresponding segment, with a dot representing fractions  $\leq 5\%$ . The upper red bar (where present) indicates the fraction of residues that have poor fit to the electron density. The numeric value is given above the bar.

Mol	Chain	Length	Quality of chain
1	A	709	
1	D	709	
1	G	709	
1	J	709	
2	B	754	
2	E	754	

*Continued on next page...*

*Continued from previous page...*

Mol	Chain	Length	Quality of chain
2	H	754	<p>6% 80% 14% 6%</p>
2	K	754	<p>8% 83% 11% 6%</p>
3	C	782	<p>21% 86% 10% •</p>
3	F	782	<p>6% 82% 15% •</p>
3	I	782	<p>11% 84% 13% ••</p>
3	L	782	<p>17% 87% 10% •</p>

## 2 Entry composition [i](#)

There are 3 unique types of molecules in this entry. The entry contains 69371 atoms, of which 0 are hydrogens and 0 are deuteriums.

In the tables below, the ZeroOcc column contains the number of atoms modelled with zero occupancy, the AltConf column contains the number of residues with at least one atom in alternate conformation and the Trace column contains the number of residues modelled with at most 2 atoms.

- Molecule 1 is a protein called Polymerase acidic protein.

Mol	Chain	Residues	Atoms					ZeroOcc	AltConf	Trace
			Total	C	N	O	S			
1	A	693	Total 5630	C 3589	N 954	O 1043	S 44	0	0	0
1	D	693	Total 5630	C 3589	N 954	O 1043	S 44	0	0	0
1	G	693	Total 5630	C 3589	N 954	O 1043	S 44	0	0	0
1	J	693	Total 5630	C 3589	N 954	O 1043	S 44	0	0	0

- Molecule 2 is a protein called RNA-directed RNA polymerase catalytic subunit.

Mol	Chain	Residues	Atoms					ZeroOcc	AltConf	Trace
			Total	C	N	O	S			
2	B	711	Total 5652	C 3587	N 956	O 1056	S 53	0	0	0
2	E	711	Total 5652	C 3587	N 956	O 1056	S 53	0	0	0
2	H	711	Total 5652	C 3587	N 956	O 1056	S 53	0	0	0
2	K	711	Total 5652	C 3587	N 956	O 1056	S 53	0	0	0

- Molecule 3 is a protein called Polymerase basic protein 2.

Mol	Chain	Residues	Atoms					ZeroOcc	AltConf	Trace
			Total	C	N	O	S			
3	C	754	Total 6015	C 3806	N 1056	O 1117	S 36	0	0	0
3	F	762	Total 6076	C 3845	N 1066	O 1128	S 37	0	0	0
3	I	762	Total 6076	C 3845	N 1066	O 1128	S 37	0	0	0
3	L	762	Total 6076	C 3845	N 1066	O 1128	S 37	0	0	0

There are 32 discrepancies between the modelled and reference sequences:

Chain	Residue	Modelled	Actual	Comment	Reference
C	775	ALA	-	expression tag	UNP Q9IMP3
C	776	ARG	-	expression tag	UNP Q9IMP3
C	777	GLU	-	expression tag	UNP Q9IMP3
C	778	ASN	-	expression tag	UNP Q9IMP3
C	779	LEU	-	expression tag	UNP Q9IMP3
C	780	TYR	-	expression tag	UNP Q9IMP3
C	781	PHE	-	expression tag	UNP Q9IMP3
C	782	GLN	-	expression tag	UNP Q9IMP3
F	775	ALA	-	expression tag	UNP Q9IMP3
F	776	ARG	-	expression tag	UNP Q9IMP3
F	777	GLU	-	expression tag	UNP Q9IMP3
F	778	ASN	-	expression tag	UNP Q9IMP3
F	779	LEU	-	expression tag	UNP Q9IMP3
F	780	TYR	-	expression tag	UNP Q9IMP3
F	781	PHE	-	expression tag	UNP Q9IMP3
F	782	GLN	-	expression tag	UNP Q9IMP3
I	775	ALA	-	expression tag	UNP Q9IMP3
I	776	ARG	-	expression tag	UNP Q9IMP3
I	777	GLU	-	expression tag	UNP Q9IMP3
I	778	ASN	-	expression tag	UNP Q9IMP3
I	779	LEU	-	expression tag	UNP Q9IMP3
I	780	TYR	-	expression tag	UNP Q9IMP3
I	781	PHE	-	expression tag	UNP Q9IMP3
I	782	GLN	-	expression tag	UNP Q9IMP3
L	775	ALA	-	expression tag	UNP Q9IMP3
L	776	ARG	-	expression tag	UNP Q9IMP3
L	777	GLU	-	expression tag	UNP Q9IMP3
L	778	ASN	-	expression tag	UNP Q9IMP3
L	779	LEU	-	expression tag	UNP Q9IMP3
L	780	TYR	-	expression tag	UNP Q9IMP3
L	781	PHE	-	expression tag	UNP Q9IMP3
L	782	GLN	-	expression tag	UNP Q9IMP3

### 3 Residue-property plots [i](#)

These plots are drawn for all protein, RNA and DNA chains in the entry. The first graphic for a chain summarises the proportions of the various outlier classes displayed in the second graphic. The second graphic shows the sequence view annotated by issues in geometry and electron density. Residues are color-coded according to the number of geometric quality criteria for which they contain at least one outlier: green = 0, yellow = 1, orange = 2 and red = 3 or more. A red dot above a residue indicates a poor fit to the electron density ( $RSRZ > 2$ ). Stretches of 2 or more consecutive residues without any outlier are shown as a green connector. Residues present in the sample, but not in the model, are shown in grey.

- Molecule 1: Polymerase acidic protein

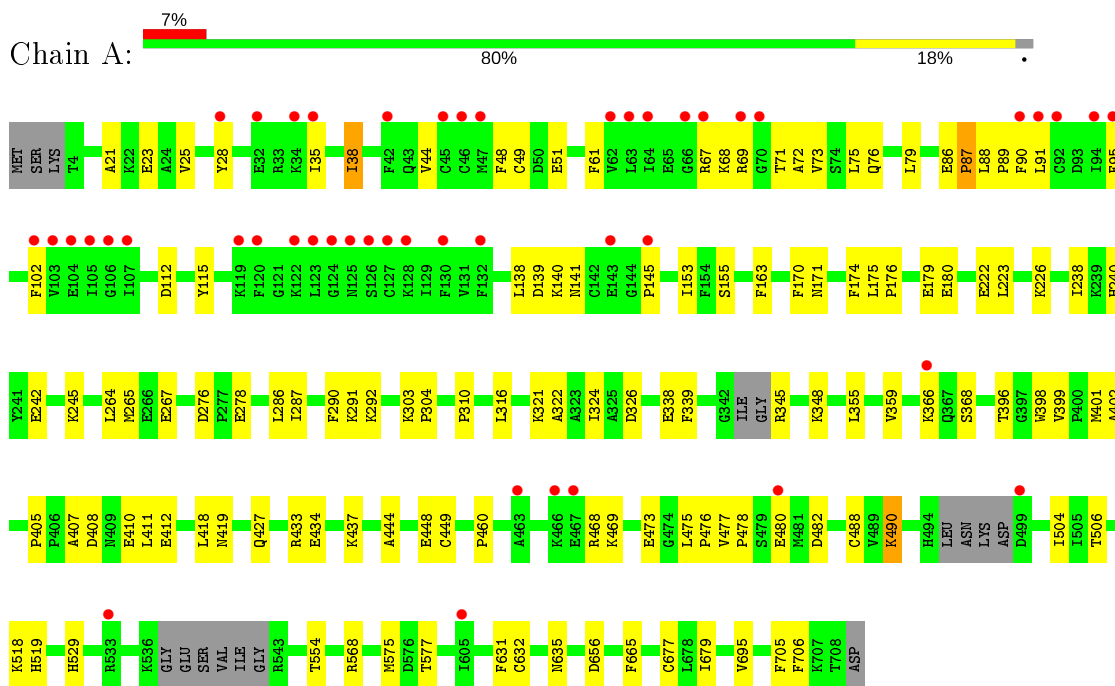

- Molecule 1: Polymerase acidic protein

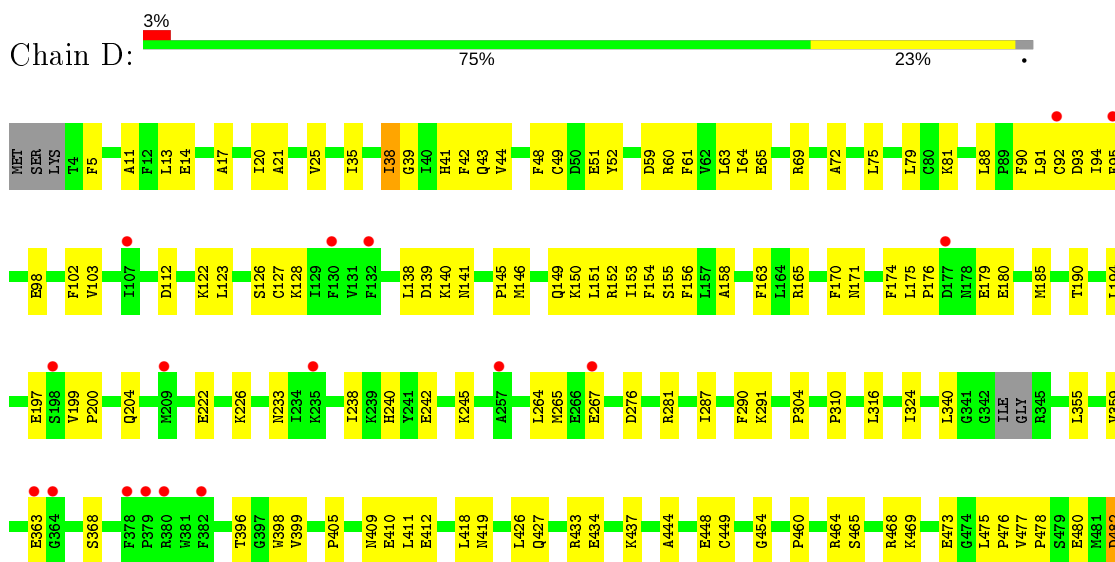

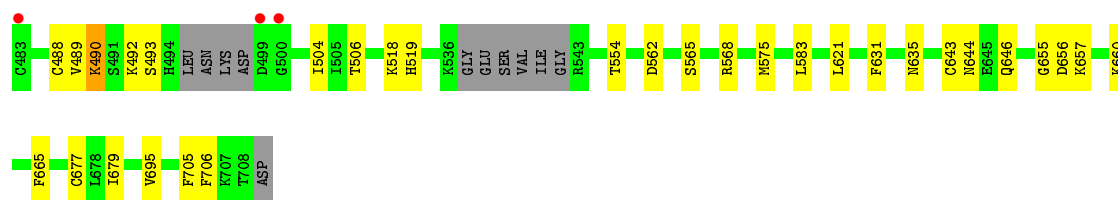

- Molecule 1: Polymerase acidic protein

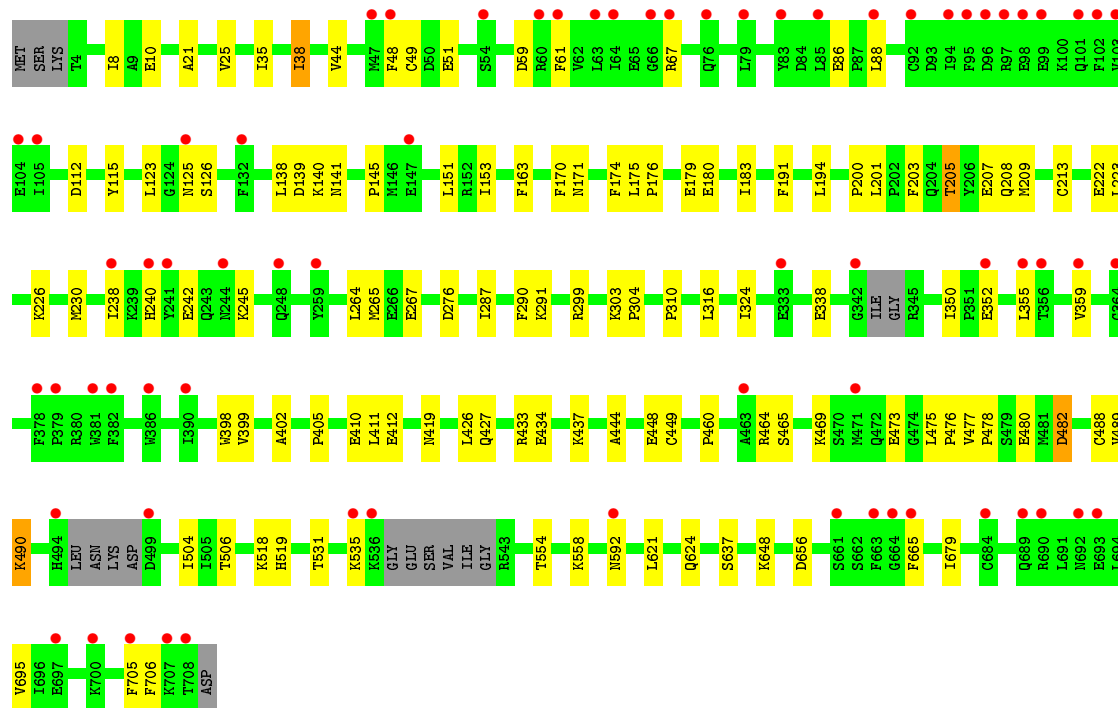
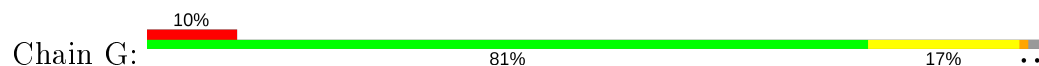

- Molecule 1: Polymerase acidic protein

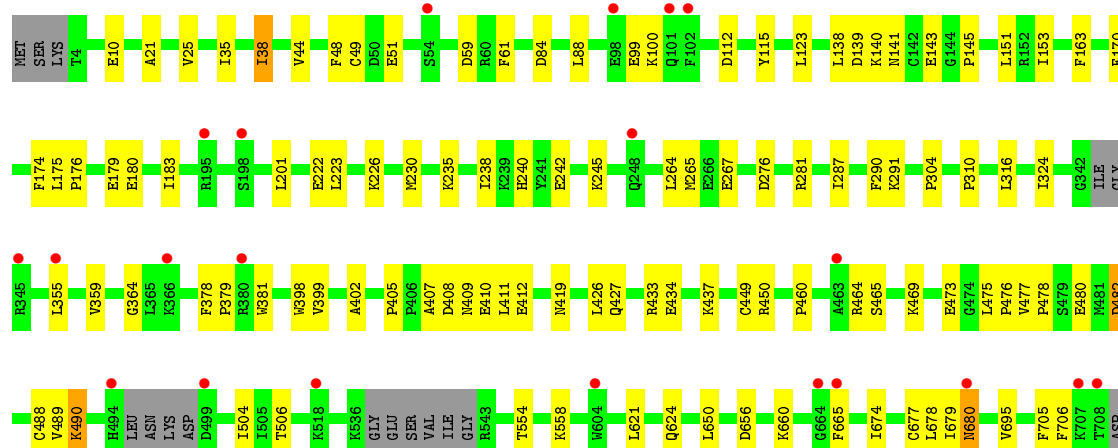
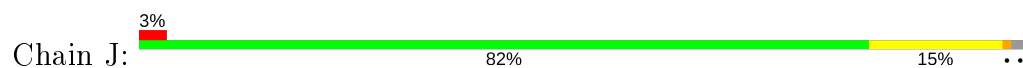

- Molecule 2: RNA-directed RNA polymerase catalytic subunit

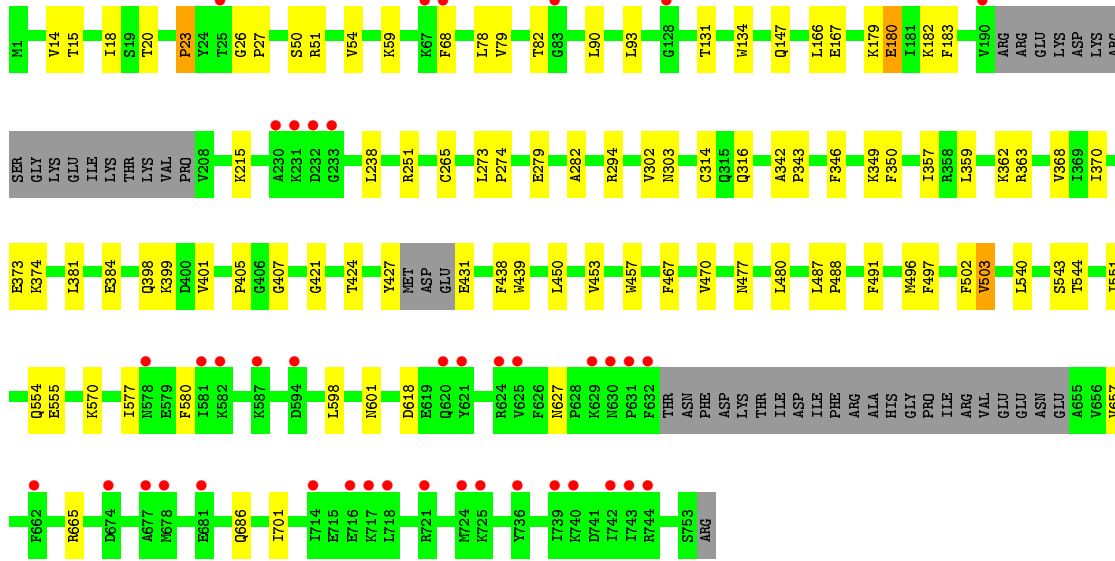

• Molecule 2: RNA-directed RNA polymerase catalytic subunit

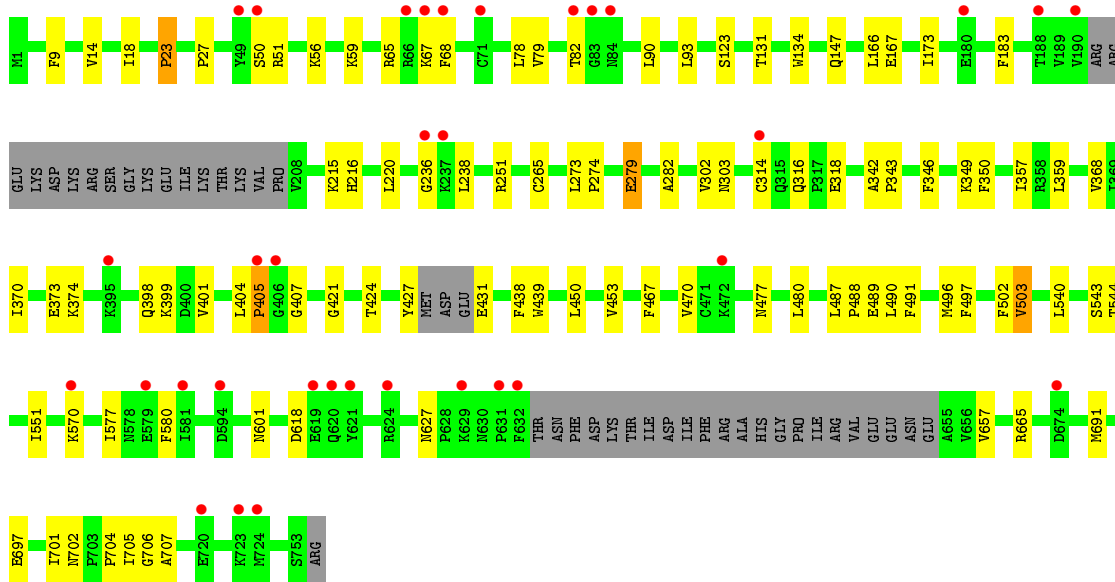
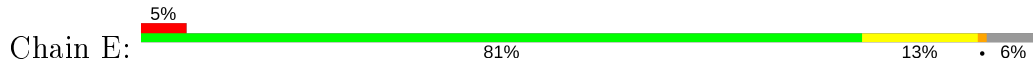

• Molecule 2: RNA-directed RNA polymerase catalytic subunit

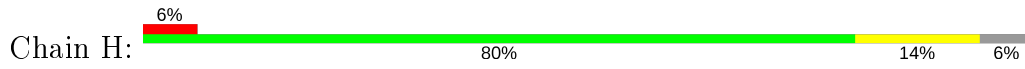



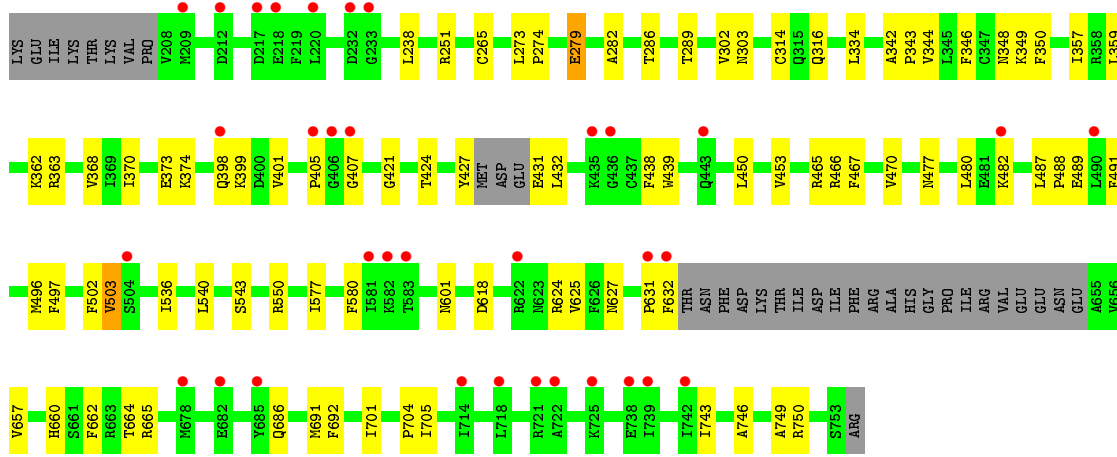

• Molecule 2: RNA-directed RNA polymerase catalytic subunit

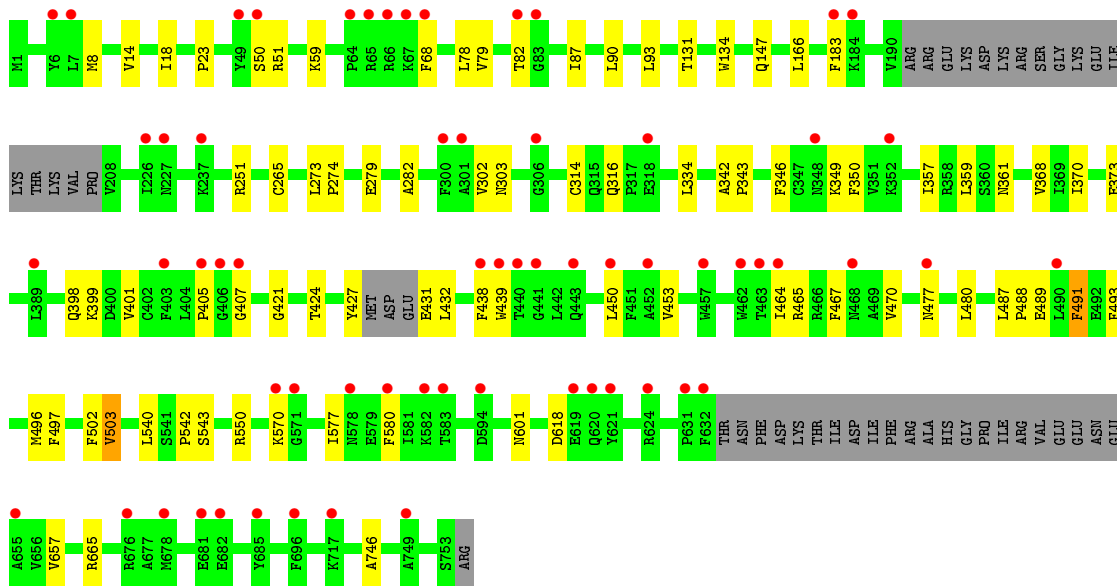
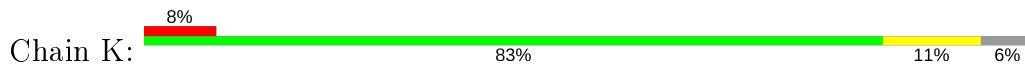

• Molecule 3: Polymerase basic protein 2

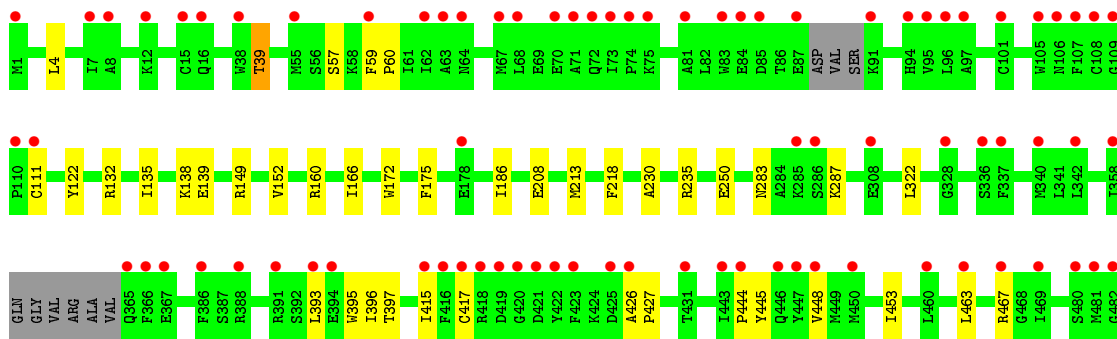
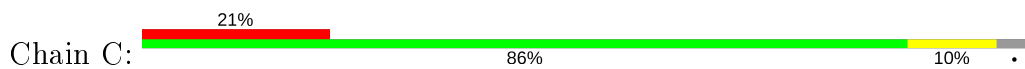

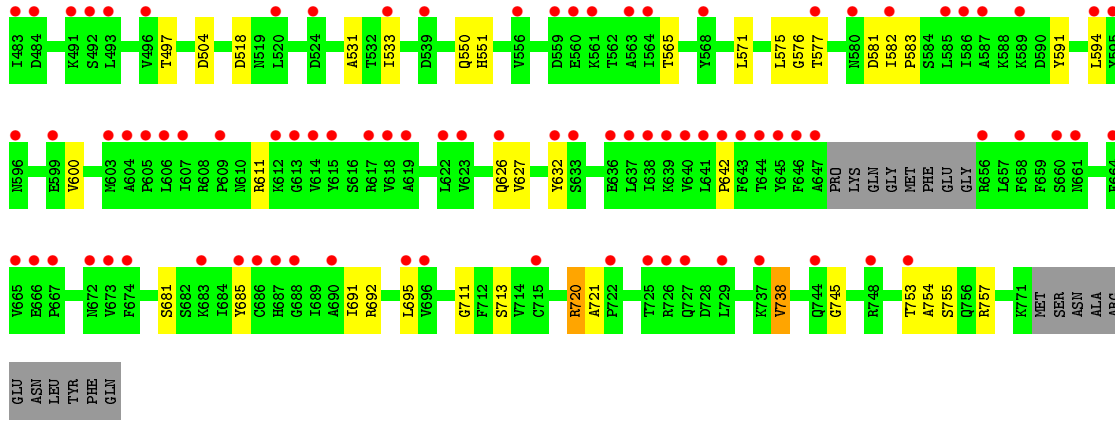

• Molecule 3: Polymerase basic protein 2

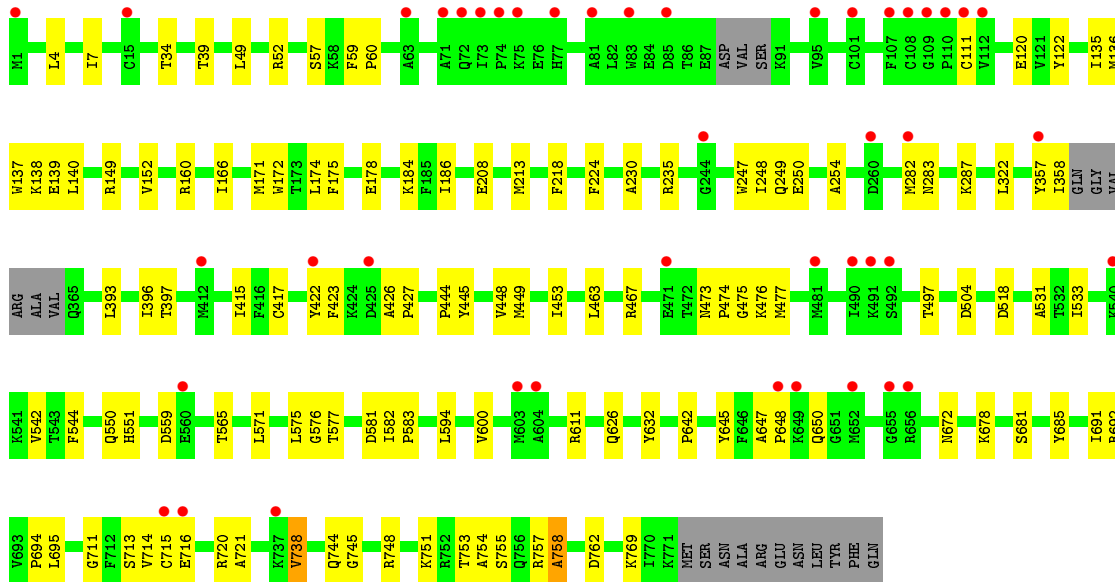
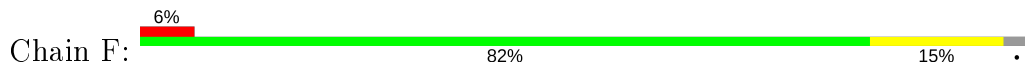

• Molecule 3: Polymerase basic protein 2

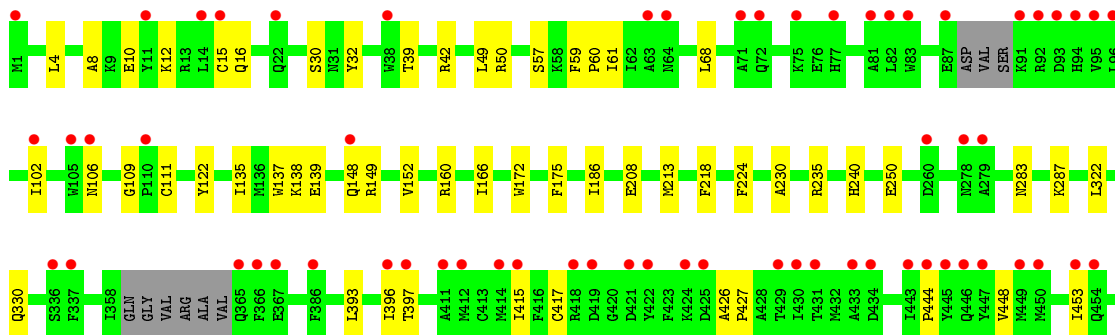
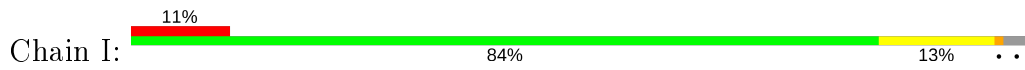

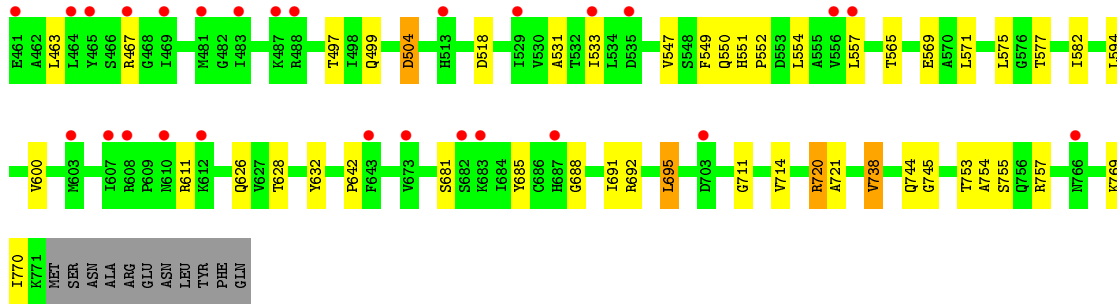

• Molecule 3: Polymerase basic protein 2

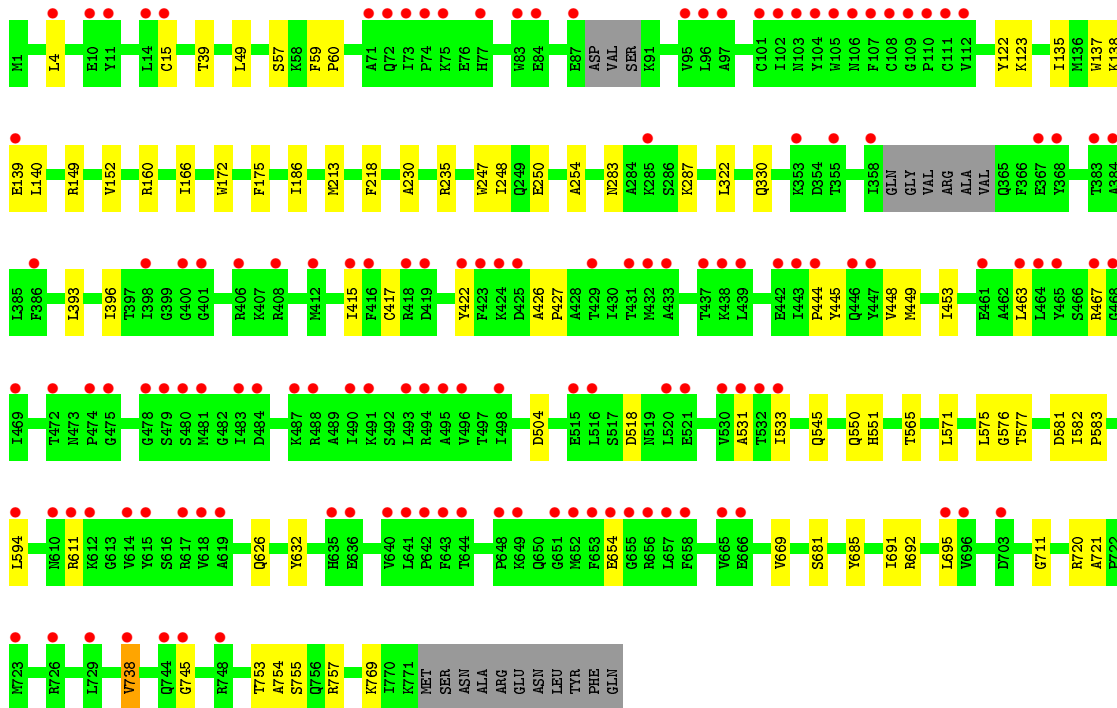
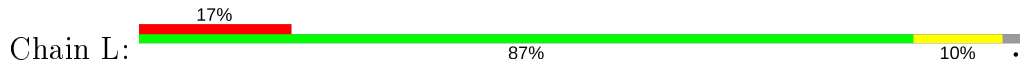

## 4 Data and refinement statistics

Property	Value	Source
Space group	P 21 21 21	Depositor
Cell constants a, b, c, $\alpha$ , $\beta$ , $\gamma$	107.28Å 217.50Å 597.75Å 90.00° 90.00° 90.00°	Depositor
Resolution (Å)	50.01 – 4.30 80.90 – 4.30	Depositor EDS
% Data completeness (in resolution range)	98.8 (50.01-4.30) 98.9 (80.90-4.30)	Depositor EDS
$R_{merge}$	0.20	Depositor
$R_{sym}$	(Not available)	Depositor
$\langle I/\sigma(I) \rangle$ <sup>1</sup>	1.54 (at 4.30Å)	Xtrriage
Refinement program	REFMAC 5.8.0124	Depositor
R, $R_{free}$	0.316 , 0.368 0.312 , 0.359	Depositor DCC
$R_{free}$ test set	4744 reflections (4.98%)	wwPDB-VP
Wilson B-factor (Å <sup>2</sup> )	146.0	Xtrriage
Anisotropy	0.501	Xtrriage
Bulk solvent $k_{sol}$ (e/Å <sup>3</sup> ), $B_{sol}$ (Å <sup>2</sup> )	0.25 , 108.9	EDS
L-test for twinning <sup>2</sup>	$\langle  L  \rangle = 0.41$ , $\langle L^2 \rangle = 0.23$	Xtrriage
Estimated twinning fraction	No twinning to report.	Xtrriage
$F_o, F_c$ correlation	0.85	EDS
Total number of atoms	69371	wwPDB-VP
Average B, all atoms (Å <sup>2</sup> )	193.0	wwPDB-VP

Xtrriage's analysis on translational NCS is as follows: *The largest off-origin peak in the Patterson function is 1.51% of the height of the origin peak. No significant pseudotranslation is detected.*

<sup>1</sup>Intensities estimated from amplitudes.

<sup>2</sup>Theoretical values of  $\langle |L| \rangle$ ,  $\langle L^2 \rangle$  for acentric reflections are 0.5, 0.333 respectively for untwinned datasets, and 0.375, 0.2 for perfectly twinned datasets.

## 5 Model quality [i](#)

### 5.1 Standard geometry [i](#)

The Z score for a bond length (or angle) is the number of standard deviations the observed value is removed from the expected value. A bond length (or angle) with  $|Z| > 5$  is considered an outlier worth inspection. RMSZ is the root-mean-square of all Z scores of the bond lengths (or angles).

Mol	Chain	Bond lengths		Bond angles	
		RMSZ	# Z  >5	RMSZ	# Z  >5
1	A	0.46	0/5746	0.65	0/7717
1	D	0.47	0/5746	0.66	0/7717
1	G	0.46	0/5746	0.64	0/7717
1	J	0.46	0/5746	0.64	0/7717
2	B	0.45	0/5749	0.65	1/7723 (0.0%)
2	E	0.44	0/5749	0.65	0/7723
2	H	0.44	0/5749	0.64	0/7723
2	K	0.43	0/5749	0.64	0/7723
3	C	0.45	0/6121	0.69	1/8236 (0.0%)
3	F	0.46	0/6185	0.69	0/8322
3	I	0.45	0/6185	0.68	1/8322 (0.0%)
3	L	0.44	0/6185	0.68	0/8322
All	All	0.45	0/70656	0.66	3/94962 (0.0%)

There are no bond length outliers.

All (3) bond angle outliers are listed below:

Mol	Chain	Res	Type	Atoms	Z	Observed(°)	Ideal(°)
3	I	720	ARG	NE-CZ-NH1	6.60	123.60	120.30
3	C	720	ARG	NE-CZ-NH1	6.55	123.58	120.30
2	B	180	GLU	OE1-CD-OE2	-6.36	115.67	123.30

There are no chirality outliers.

There are no planarity outliers.

### 5.2 Too-close contacts [i](#)

In the following table, the Non-H and H(model) columns list the number of non-hydrogen atoms and hydrogen atoms in the chain respectively. The H(added) column lists the number of hydrogen atoms added and optimized by MolProbity. The Clashes column lists the number of clashes within the asymmetric unit, whereas Symm-Clashes lists symmetry related clashes.

Mol	Chain	Non-H	H(model)	H(added)	Clashes	Symm-Clashes
1	A	5630	0	5632	144	1
1	D	5630	0	5632	192	5
1	G	5630	0	5632	167	2
1	J	5630	0	5632	116	6
2	B	5652	0	5749	122	6
2	E	5652	0	5749	104	4
2	H	5652	0	5749	129	0
2	K	5652	0	5749	77	0
3	C	6015	0	6124	54	0
3	F	6076	0	6183	171	8
3	I	6076	0	6183	119	4
3	L	6076	0	6183	80	0
All	All	69371	0	70197	1164	18

The all-atom clashscore is defined as the number of clashes found per 1000 atoms (including hydrogen atoms). The all-atom clashscore for this structure is 8.

All (1164) close contacts within the same asymmetric unit are listed below, sorted by their clash magnitude.

Atom-1	Atom-2	Interatomic distance (Å)	Clash overlap (Å)
1:D:69:ARG:CZ	1:D:91:LEU:HD11	1.14	1.55
2:B:180:GLU:HG2	1:G:203:PHE:CE1	1.47	1.50
3:I:577:THR:HG23	3:I:754:ALA:CB	1.43	1.49
2:H:363:ARG:HA	1:J:409:ASN:ND2	1.20	1.42
1:D:69:ARG:NE	1:D:91:LEU:HD11	1.33	1.41
3:I:575:LEU:CD1	3:I:582:ILE:HD12	1.55	1.36
2:H:363:ARG:CA	1:J:409:ASN:HD22	1.35	1.35
1:A:355:LEU:HD11	1:A:366:LYS:NZ	1.38	1.34
1:J:674:ILE:O	1:J:678:LEU:HD13	1.23	1.34
2:B:180:GLU:OE2	2:B:215:LYS:HD3	1.24	1.31
2:E:68:PHE:CE1	2:E:316:GLN:OE1	1.83	1.31
2:B:68:PHE:CE1	2:B:316:GLN:OE1	1.82	1.30
2:H:68:PHE:CE1	2:H:316:GLN:OE1	1.83	1.29
2:K:68:PHE:CE1	2:K:316:GLN:OE1	1.84	1.29
1:D:69:ARG:CZ	1:D:91:LEU:CD1	2.09	1.28
2:K:18:ILE:HD12	2:K:497:PHE:CD1	1.68	1.26
2:E:18:ILE:HD12	2:E:497:PHE:CD1	1.69	1.26
2:B:180:GLU:CG	1:G:203:PHE:CE1	2.17	1.25
3:F:358:ILE:HA	3:F:423:PHE:CB	1.65	1.24
3:I:577:THR:CG2	3:I:754:ALA:HB2	1.67	1.23
1:J:674:ILE:O	1:J:678:LEU:CD1	1.90	1.20
3:F:474:PRO:HD3	1:G:126:SER:HA	1.25	1.16

*Continued on next page...*

*Continued from previous page...*

Atom-1	Atom-2	Interatomic distance (Å)	Clash overlap (Å)
3:I:575:LEU:HD13	3:I:582:ILE:HD12	1.17	1.16
3:F:474:PRO:CD	1:G:126:SER:HA	1.75	1.16
3:I:554:LEU:HD11	3:I:557:LEU:HG	1.17	1.16
2:B:180:GLU:OE2	2:B:215:LYS:CD	1.94	1.14
2:K:18:ILE:CD1	2:K:497:PHE:CD1	2.29	1.14
2:E:18:ILE:CD1	2:E:497:PHE:CD1	2.30	1.14
3:C:575:LEU:HD13	3:C:582:ILE:HD12	1.30	1.13
1:D:396:THR:HG21	1:D:468:ARG:HD2	1.30	1.13
1:A:366:LYS:HE3	2:B:359:LEU:CD1	1.79	1.12
3:F:575:LEU:HD13	3:F:582:ILE:HD12	1.30	1.11
1:J:408:ASP:N	1:J:412:GLU:HG3	1.65	1.11
1:J:408:ASP:H	1:J:412:GLU:CG	1.63	1.11
1:A:396:THR:HG21	1:A:468:ARG:HD2	1.29	1.10
3:F:477:MET:CE	1:G:88:LEU:HD11	1.81	1.10
1:D:90:PHE:CZ	1:D:122:LYS:HB3	1.85	1.10
1:D:69:ARG:NE	1:D:91:LEU:CD1	2.09	1.10
3:L:575:LEU:HD13	3:L:582:ILE:HD12	1.31	1.10
2:H:363:ARG:CA	1:J:409:ASN:ND2	1.99	1.10
1:A:407:ALA:HB1	1:A:412:GLU:HB3	1.14	1.08
2:B:363:ARG:NH2	3:F:139:GLU:OE2	1.85	1.08
3:C:575:LEU:CD1	3:C:582:ILE:HD12	1.84	1.07
3:F:358:ILE:CA	3:F:423:PHE:HB3	1.83	1.07
3:F:575:LEU:CD1	3:F:582:ILE:HD12	1.83	1.07
3:L:575:LEU:CD1	3:L:582:ILE:HD12	1.84	1.06
1:D:90:PHE:HB2	1:D:123:LEU:HD11	1.31	1.06
1:A:407:ALA:CB	1:A:412:GLU:HB3	1.85	1.05
1:D:152:ARG:NH2	3:F:757:ARG:O	1.89	1.04
3:F:474:PRO:CG	1:G:126:SER:HA	1.86	1.04
1:A:396:THR:HG21	1:A:468:ARG:CD	1.88	1.04
3:C:692:ARG:NH2	3:C:755:SER:OG	1.91	1.03
3:F:692:ARG:NH2	3:F:755:SER:OG	1.89	1.03
3:I:547:VAL:HG13	3:I:688:GLY:HA2	1.35	1.03
3:I:575:LEU:HD13	3:I:582:ILE:CD1	1.88	1.03
3:I:554:LEU:HD11	3:I:557:LEU:CG	1.89	1.03
3:I:692:ARG:NH2	3:I:755:SER:OG	1.92	1.02
1:D:396:THR:HG21	1:D:468:ARG:CD	1.88	1.02
3:L:576:GLY:HA2	3:L:583:PRO:HG3	1.42	1.02
3:L:692:ARG:NH2	3:L:755:SER:OG	1.91	1.01
1:A:407:ALA:HB1	1:A:412:GLU:CB	1.90	1.01
3:F:477:MET:HE1	1:G:88:LEU:CD1	1.89	1.01
1:A:355:LEU:CD1	1:A:366:LYS:NZ	2.24	1.00

*Continued on next page...*

*Continued from previous page...*

Atom-1	Atom-2	Interatomic distance (Å)	Clash overlap (Å)
3:C:576:GLY:HA2	3:C:583:PRO:HG3	1.44	1.00
2:B:180:GLU:HB2	1:G:203:PHE:CD1	1.96	0.99
1:D:90:PHE:CB	1:D:123:LEU:HD11	1.92	0.99
3:I:755:SER:O	3:I:757:ARG:HG3	1.63	0.98
1:J:408:ASP:H	1:J:412:GLU:HG3	0.84	0.98
3:C:575:LEU:HD13	3:C:582:ILE:CD1	1.94	0.98
3:F:576:GLY:HA2	3:F:583:PRO:HG3	1.42	0.98
3:F:575:LEU:HD13	3:F:582:ILE:CD1	1.92	0.98
2:K:487:LEU:HD23	2:K:488:PRO:N	1.79	0.98
3:L:575:LEU:HD13	3:L:582:ILE:CD1	1.94	0.98
3:F:477:MET:SD	1:G:88:LEU:HD13	2.04	0.98
1:A:326:ASP:HB3	3:F:542:VAL:HG23	1.44	0.97
2:H:686:GLN:OE1	3:I:39:THR:CG2	2.12	0.97
1:G:203:PHE:HB3	1:G:208:GLN:HE21	1.28	0.97
1:A:76:GLN:HB2	1:A:91:LEU:CD2	1.94	0.97
2:E:487:LEU:HD23	2:E:488:PRO:N	1.79	0.97
3:C:755:SER:O	3:C:757:ARG:HG3	1.65	0.97
3:F:477:MET:HE1	1:G:88:LEU:HD11	0.97	0.97
2:H:487:LEU:HD23	2:H:488:PRO:N	1.79	0.97
3:I:575:LEU:CD1	3:I:582:ILE:CD1	2.44	0.96
3:L:755:SER:O	3:L:757:ARG:HG3	1.66	0.95
1:A:355:LEU:HD11	1:A:366:LYS:HZ1	1.16	0.95
3:F:576:GLY:HA2	3:F:583:PRO:CG	1.96	0.95
1:A:76:GLN:HB2	1:A:91:LEU:HD21	1.48	0.95
1:A:366:LYS:CE	2:B:359:LEU:CD1	2.44	0.95
2:K:68:PHE:HE1	2:K:316:GLN:OE1	1.32	0.94
3:I:552:PRO:HG2	3:I:554:LEU:HG	1.47	0.93
1:G:412:GLU:N	1:G:412:GLU:OE1	2.00	0.93
1:D:412:GLU:N	1:D:412:GLU:OE1	2.00	0.93
3:F:358:ILE:HA	3:F:423:PHE:HB3	0.96	0.93
3:F:474:PRO:HB3	1:G:126:SER:OG	1.69	0.93
2:B:182:LYS:NZ	1:G:205:THR:HG23	1.84	0.92
2:H:686:GLN:OE1	3:I:39:THR:HG21	1.69	0.92
2:H:363:ARG:HG2	1:J:409:ASN:HB2	1.50	0.92
3:C:576:GLY:HA2	3:C:583:PRO:CG	1.99	0.92
3:L:576:GLY:HA2	3:L:583:PRO:CG	1.97	0.92
2:B:180:GLU:HG2	1:G:203:PHE:CZ	2.05	0.91
3:I:577:THR:HG23	3:I:754:ALA:HB1	1.51	0.91
3:F:474:PRO:HD3	1:G:126:SER:CA	2.00	0.91
1:A:355:LEU:HD11	1:A:366:LYS:HZ2	1.10	0.90
1:D:92:CYS:SG	1:D:102:PHE:HD2	1.93	0.90

*Continued on next page...*



*Continued from previous page...*

Atom-1	Atom-2	Interatomic distance (Å)	Clash overlap (Å)
1:D:410:GLU:HB3	3:F:137:TRP:HB3	1.53	0.90
2:H:701:ILE:HD11	3:I:208:GLU:HA	1.54	0.89
1:A:410:GLU:OE1	1:A:411:LEU:HB2	1.72	0.89
1:D:69:ARG:NH1	1:D:91:LEU:HD11	1.88	0.88
3:F:577:THR:HG23	3:F:754:ALA:HB2	1.55	0.88
2:E:68:PHE:HE1	2:E:316:GLN:OE1	1.31	0.88
1:D:59:ASP:OD2	3:F:769:LYS:NZ	2.07	0.88
2:H:68:PHE:HE1	2:H:316:GLN:OE1	1.31	0.87
2:B:179:LYS:HB2	1:G:203:PHE:CZ	2.09	0.87
2:K:50:SER:HB3	2:K:68:PHE:CE1	2.10	0.87
3:F:358:ILE:HA	3:F:423:PHE:CA	2.03	0.87
2:H:50:SER:HB3	2:H:68:PHE:CE1	2.09	0.86
2:B:180:GLU:CB	1:G:203:PHE:CE1	2.58	0.86
2:B:50:SER:OG	2:B:68:PHE:CZ	2.29	0.86
2:B:487:LEU:CD1	2:B:488:PRO:HD2	2.05	0.86
2:K:50:SER:OG	2:K:68:PHE:CZ	2.29	0.85
2:H:50:SER:OG	2:H:68:PHE:CZ	2.29	0.85
2:H:686:GLN:NE2	3:I:39:THR:OG1	2.09	0.85
2:B:50:SER:HB3	2:B:68:PHE:CE1	2.11	0.85
2:E:50:SER:HB3	2:E:68:PHE:CE1	2.10	0.85
1:J:408:ASP:O	1:J:412:GLU:HB2	1.75	0.85
2:E:50:SER:OG	2:E:68:PHE:CZ	2.29	0.85
3:F:576:GLY:HA2	3:F:583:PRO:CD	2.06	0.85
2:K:18:ILE:HD12	2:K:497:PHE:CE1	2.12	0.85
1:D:410:GLU:HG2	3:F:137:TRP:CE3	2.11	0.84
2:H:363:ARG:HA	1:J:409:ASN:CG	1.97	0.84
3:I:577:THR:CG2	3:I:754:ALA:CB	2.39	0.84
2:B:68:PHE:HE1	2:B:316:GLN:OE1	1.30	0.84
2:H:487:LEU:HG	2:H:488:PRO:HD2	1.59	0.84
3:I:577:THR:HG23	3:I:754:ALA:HB2	0.84	0.83
2:K:487:LEU:HG	2:K:488:PRO:HD2	1.59	0.83
2:B:487:LEU:HD12	2:B:488:PRO:CD	2.08	0.83
1:D:92:CYS:HG	1:D:102:PHE:HD2	0.85	0.83
2:H:363:ARG:C	1:J:409:ASN:ND2	2.31	0.83
2:E:18:ILE:HD12	2:E:497:PHE:CE1	2.13	0.83
3:F:358:ILE:C	3:F:423:PHE:O	2.04	0.83
2:B:182:LYS:HZ1	1:G:205:THR:HG23	1.43	0.83
3:I:554:LEU:CD1	3:I:557:LEU:H	1.91	0.83
1:A:529:HIS:CE1	3:F:678:LYS:HE2	2.14	0.83
2:B:180:GLU:CG	1:G:203:PHE:CD1	2.62	0.83
3:I:554:LEU:O	3:I:554:LEU:HD12	1.79	0.83

*Continued on next page...*

*Continued from previous page...*

Atom-1	Atom-2	Interatomic distance (Å)	Clash overlap (Å)
3:L:576:GLY:HA2	3:L:583:PRO:CD	2.10	0.82
2:E:487:LEU:HG	2:E:488:PRO:HD2	1.60	0.82
1:A:72:ALA:O	1:A:91:LEU:HD21	1.78	0.81
1:J:419:ASN:ND2	2:K:543:SER:OG	2.13	0.81
3:L:138:LYS:HB3	3:L:250:GLU:HB2	1.60	0.81
2:B:363:ARG:CD	3:F:139:GLU:OE2	2.28	0.81
1:D:90:PHE:CE2	1:D:122:LYS:HB3	2.14	0.81
1:G:419:ASN:ND2	2:H:543:SER:OG	2.14	0.81
3:I:552:PRO:CG	3:I:557:LEU:HD12	2.10	0.81
3:F:138:LYS:HB3	3:F:250:GLU:HB2	1.63	0.81
1:A:355:LEU:CD1	1:A:366:LYS:HZ2	1.86	0.80
2:B:180:GLU:HB2	1:G:203:PHE:HD1	1.40	0.80
2:B:180:GLU:HG2	1:G:203:PHE:HE1	1.35	0.80
1:D:11:ALA:O	3:F:184:LYS:NZ	2.15	0.80
1:A:338:GLU:HG2	3:F:254:ALA:HB1	1.64	0.80
3:F:477:MET:SD	1:G:88:LEU:CD1	2.69	0.80
1:A:396:THR:CG2	1:A:468:ARG:HD2	2.12	0.79
3:C:576:GLY:HA2	3:C:583:PRO:CD	2.11	0.79
3:I:552:PRO:HG3	3:I:557:LEU:HD11	1.65	0.79
1:G:469:LYS:HD3	1:G:475:LEU:HD13	1.64	0.79
1:A:286:LEU:HD11	1:A:482:ASP:OD2	1.81	0.79
1:D:396:THR:CG2	1:D:468:ARG:HD2	2.12	0.79
1:G:171:ASN:ND2	2:H:167:GLU:OE2	2.15	0.79
1:J:469:LYS:HD3	1:J:475:LEU:HD13	1.65	0.79
2:K:50:SER:CB	2:K:68:PHE:CZ	2.66	0.79
2:B:180:GLU:CB	1:G:203:PHE:CD1	2.66	0.79
2:H:627:ASN:ND2	3:I:111:CYS:SG	2.56	0.78
2:B:50:SER:CB	2:B:68:PHE:CZ	2.67	0.78
1:A:469:LYS:HD3	1:A:475:LEU:HD13	1.64	0.78
2:E:50:SER:HB3	2:E:68:PHE:CZ	2.19	0.78
2:K:50:SER:HB3	2:K:68:PHE:CZ	2.19	0.78
2:B:363:ARG:HA	1:D:409:ASN:ND2	1.99	0.77
2:E:50:SER:CB	2:E:68:PHE:CZ	2.67	0.77
3:L:575:LEU:HD13	3:L:582:ILE:CG1	2.15	0.77
1:D:410:GLU:OE1	1:D:411:LEU:HB2	1.85	0.77
1:G:209:MET:SD	1:G:213:CYS:SG	2.82	0.77
1:D:575:MET:HG2	2:E:544:THR:HA	1.67	0.77
2:H:50:SER:HB3	2:H:68:PHE:CZ	2.19	0.77
2:H:50:SER:CB	2:H:68:PHE:CZ	2.66	0.77
1:A:355:LEU:CD1	1:A:366:LYS:HZ1	1.90	0.77
1:A:326:ASP:HB3	3:F:542:VAL:CG2	2.15	0.77

*Continued on next page...*

*Continued from previous page...*

Atom-1	Atom-2	Interatomic distance (Å)	Clash overlap (Å)
2:B:50:SER:HB3	2:B:68:PHE:CZ	2.19	0.77
1:D:90:PHE:HB2	1:D:123:LEU:CD1	2.14	0.77
1:D:469:LYS:HD3	1:D:475:LEU:HD13	1.65	0.76
3:F:577:THR:HG23	3:F:754:ALA:CB	2.14	0.76
3:F:575:LEU:HD13	3:F:582:ILE:CG1	2.14	0.76
3:I:575:LEU:HD11	3:I:582:ILE:HD12	1.67	0.76
1:G:410:GLU:OE1	1:G:411:LEU:HB2	1.86	0.76
1:A:366:LYS:CE	2:B:359:LEU:HD11	2.15	0.75
1:A:366:LYS:HE3	2:B:359:LEU:HD13	1.68	0.75
3:C:575:LEU:HD13	3:C:582:ILE:CG1	2.16	0.75
2:B:487:LEU:HG	2:B:488:PRO:HD2	1.68	0.75
1:D:48:PHE:O	1:D:149:GLN:NE2	2.20	0.75
1:D:69:ARG:HE	1:D:91:LEU:HD21	1.52	0.75
3:F:577:THR:CG2	3:F:754:ALA:HB2	2.16	0.75
3:I:575:LEU:HD13	3:I:582:ILE:CG1	2.17	0.75
3:I:552:PRO:HG3	3:I:557:LEU:CD1	2.17	0.74
1:D:410:GLU:OE1	1:D:411:LEU:CB	2.36	0.74
1:D:477:VAL:HG11	1:D:480:GLU:OE2	1.88	0.74
2:H:363:ARG:HA	1:J:409:ASN:HD22	0.61	0.74
2:B:182:LYS:HE2	1:G:205:THR:OG1	1.87	0.74
1:A:366:LYS:HE3	2:B:359:LEU:HD12	1.69	0.74
1:D:410:GLU:HG2	3:F:137:TRP:CD2	2.22	0.74
1:D:44:VAL:HG13	1:D:153:ILE:HD11	1.70	0.74
1:D:477:VAL:HG12	1:D:478:PRO:O	1.88	0.74
1:J:477:VAL:HG11	1:J:480:GLU:OE2	1.88	0.73
1:A:286:LEU:HD21	1:A:482:ASP:OD2	1.88	0.73
1:A:89:PRO:HG2	1:A:90:PHE:CD1	2.24	0.73
1:D:52:TYR:CD2	1:D:146:MET:HE3	2.23	0.73
1:G:477:VAL:HG12	1:G:478:PRO:O	1.88	0.73
1:G:44:VAL:HG13	1:G:153:ILE:HD11	1.71	0.73
1:A:477:VAL:HG11	1:A:480:GLU:OE2	1.88	0.73
2:K:487:LEU:CD2	2:K:488:PRO:HD2	2.18	0.73
2:K:487:LEU:CG	2:K:488:PRO:HD2	2.19	0.73
1:G:477:VAL:HG11	1:G:480:GLU:OE2	1.88	0.73
2:H:487:LEU:CD2	2:H:488:PRO:HD2	2.19	0.73
2:B:487:LEU:HD12	2:B:488:PRO:HD3	1.70	0.72
2:E:282:ALA:HB3	3:F:149:ARG:HD3	1.71	0.72
3:I:552:PRO:CG	3:I:557:LEU:CD1	2.67	0.72
2:K:18:ILE:CD1	2:K:497:PHE:HD1	2.02	0.72
2:B:487:LEU:CG	2:B:488:PRO:HD2	2.20	0.72
1:G:203:PHE:CB	1:G:208:GLN:HE21	2.02	0.72

*Continued on next page...*

*Continued from previous page...*

Atom-1	Atom-2	Interatomic distance (Å)	Clash overlap (Å)
1:G:410:GLU:OE1	1:G:411:LEU:CB	2.37	0.72
1:G:350:ILE:HB	2:H:368:VAL:HG22	1.69	0.72
1:A:44:VAL:HG13	1:A:153:ILE:HD11	1.70	0.72
1:A:477:VAL:HG12	1:A:478:PRO:O	1.89	0.72
3:F:477:MET:CE	1:G:88:LEU:CD1	2.57	0.72
2:H:487:LEU:CG	2:H:488:PRO:HD2	2.20	0.72
1:J:477:VAL:HG12	1:J:478:PRO:O	1.88	0.72
2:E:487:LEU:CD2	2:E:488:PRO:HD2	2.18	0.72
2:H:15:THR:HA	2:H:18:ILE:CD1	2.20	0.72
2:B:487:LEU:HD12	2:B:488:PRO:HD2	1.70	0.72
2:E:50:SER:CB	2:E:68:PHE:CE1	2.73	0.72
1:A:76:GLN:NE2	1:A:88:LEU:O	2.23	0.71
2:E:487:LEU:CG	2:E:488:PRO:HD2	2.20	0.71
2:E:487:LEU:HD23	2:E:488:PRO:CD	2.20	0.71
1:J:138:LEU:HD11	1:J:140:LYS:HE3	1.72	0.71
1:J:44:VAL:HG13	1:J:153:ILE:HD11	1.70	0.71
2:B:50:SER:CB	2:B:68:PHE:CE1	2.74	0.71
1:G:138:LEU:HD11	1:G:140:LYS:HE3	1.72	0.71
1:A:76:GLN:HB2	1:A:91:LEU:HD23	1.71	0.71
1:J:680:ASN:HD22	1:J:680:ASN:H	1.35	0.71
2:K:50:SER:CB	2:K:68:PHE:CE1	2.73	0.71
2:B:15:THR:HA	2:B:18:ILE:CD1	2.21	0.71
1:D:52:TYR:CD1	1:D:146:MET:HE1	2.25	0.71
2:K:487:LEU:HD23	2:K:488:PRO:CD	2.20	0.71
2:H:50:SER:CB	2:H:68:PHE:CE1	2.73	0.70
2:H:14:VAL:O	2:H:18:ILE:HG13	1.91	0.70
3:I:692:ARG:HH22	3:I:755:SER:CB	2.04	0.70
2:H:487:LEU:HD23	2:H:488:PRO:CD	2.20	0.70
1:J:410:GLU:OE1	1:J:411:LEU:HB2	1.90	0.70
1:A:366:LYS:HE2	2:B:381:LEU:HD21	1.74	0.70
1:A:366:LYS:HE2	2:B:381:LEU:CD2	2.22	0.70
2:B:363:ARG:HA	1:D:409:ASN:HD22	1.57	0.70
2:B:14:VAL:O	2:B:18:ILE:HG13	1.92	0.70
1:A:23:GLU:OE1	1:A:68:LYS:HD3	1.91	0.69
1:A:138:LEU:HD11	1:A:140:LYS:HE3	1.73	0.69
3:F:358:ILE:CA	3:F:423:PHE:C	2.57	0.69
3:F:474:PRO:CB	1:G:126:SER:HA	2.22	0.69
1:A:73:VAL:HA	1:A:91:LEU:HD11	1.73	0.69
1:D:69:ARG:CD	1:D:91:LEU:CD1	2.70	0.69
3:C:692:ARG:HH22	3:C:755:SER:CB	2.06	0.69
3:F:575:LEU:CD1	3:F:582:ILE:CD1	2.61	0.69

*Continued on next page...*

*Continued from previous page...*

Atom-1	Atom-2	Interatomic distance (Å)	Clash overlap (Å)
1:D:138:LEU:HD11	1:D:140:LYS:HE3	1.74	0.69
1:G:477:VAL:HG13	1:G:478:PRO:HD2	1.75	0.69
1:D:477:VAL:HG13	1:D:478:PRO:HD2	1.76	0.68
2:H:363:ARG:HD3	3:L:139:GLU:OE2	1.93	0.68
2:B:180:GLU:HB2	1:G:203:PHE:CE1	2.25	0.68
1:J:408:ASP:N	1:J:412:GLU:CG	2.40	0.68
1:A:477:VAL:HG13	1:A:478:PRO:HD2	1.76	0.68
2:K:487:LEU:CD2	2:K:489:GLU:H	2.07	0.68
1:D:21:ALA:HA	1:D:38:ILE:HD11	1.75	0.68
1:D:69:ARG:NH2	1:D:91:LEU:HD11	1.99	0.68
3:I:547:VAL:HG13	3:I:688:GLY:CA	2.18	0.67
1:A:366:LYS:CE	2:B:359:LEU:HD13	2.22	0.67
3:L:692:ARG:HH22	3:L:755:SER:CB	2.06	0.67
1:A:89:PRO:HG2	1:A:90:PHE:HD1	1.59	0.67
1:J:477:VAL:HG13	1:J:478:PRO:HD2	1.76	0.67
1:A:366:LYS:HE2	2:B:359:LEU:HD11	1.74	0.67
1:D:304:PRO:HG3	1:D:310:PRO:HB3	1.76	0.67
1:G:299:ARG:NE	3:L:545:GLN:HE22	1.92	0.67
1:J:304:PRO:HG3	1:J:310:PRO:HB3	1.77	0.67
1:A:322:ALA:HA	3:F:544:PHE:CD1	2.29	0.67
1:J:678:LEU:N	1:J:678:LEU:HD12	2.10	0.67
3:F:474:PRO:HG3	1:G:126:SER:HA	1.75	0.66
1:D:103:VAL:HG22	1:D:128:LYS:HB2	1.77	0.66
1:D:151:LEU:CD2	3:F:715:CYS:HB2	2.24	0.66
2:H:282:ALA:HB2	3:I:148:GLN:HG2	1.76	0.66
2:H:664:THR:HG23	3:I:42:ARG:HH11	1.59	0.66
1:D:69:ARG:CD	1:D:91:LEU:HD11	2.25	0.66
1:D:155:SER:HB3	3:F:713:SER:OG	1.95	0.66
3:I:575:LEU:HD22	3:I:582:ILE:H	1.60	0.66
2:B:180:GLU:N	1:G:203:PHE:HE1	1.93	0.66
2:H:363:ARG:O	1:J:409:ASN:ND2	2.28	0.66
1:J:410:GLU:OE1	1:J:411:LEU:CB	2.44	0.66
2:B:180:GLU:OE2	2:B:215:LYS:CE	2.43	0.66
1:A:304:PRO:HG3	1:A:310:PRO:HB3	1.77	0.65
1:A:67:ARG:HD3	1:A:71:THR:CG2	2.26	0.65
3:I:552:PRO:CG	3:I:554:LEU:HG	2.26	0.65
2:E:18:ILE:CD1	2:E:497:PHE:HD1	2.03	0.65
1:G:304:PRO:HG3	1:G:310:PRO:HB3	1.77	0.65
1:D:154:PHE:CD2	3:F:715:CYS:O	2.49	0.65
3:F:475:GLY:C	1:G:86:GLU:HG3	2.17	0.65
1:G:10:GLU:HB2	3:I:330:GLN:HE22	1.61	0.65

*Continued on next page...*

*Continued from previous page...*

Atom-1	Atom-2	Interatomic distance (Å)	Clash overlap (Å)
1:J:230:MET:SD	2:K:465:ARG:HB3	2.37	0.65
1:D:151:LEU:HD23	3:F:715:CYS:HB2	1.76	0.65
2:K:349:LYS:NZ	2:K:407:GLY:O	2.25	0.65
1:D:52:TYR:CZ	1:D:146:MET:HB2	2.33	0.64
2:K:487:LEU:HD23	2:K:489:GLU:H	1.61	0.64
2:H:487:LEU:CD2	2:H:489:GLU:H	2.09	0.64
1:D:233:ASN:HA	2:E:78:LEU:HD12	1.80	0.64
3:L:753:THR:HG22	3:L:754:ALA:N	2.13	0.64
1:D:88:LEU:HD12	1:D:123:LEU:HD22	1.78	0.64
2:B:179:LYS:CB	1:G:203:PHE:CZ	2.80	0.64
3:L:575:LEU:HD12	3:L:582:ILE:HD12	1.79	0.64
3:F:358:ILE:HA	3:F:423:PHE:C	2.18	0.64
3:F:474:PRO:HB3	1:G:126:SER:CA	2.28	0.64
1:G:230:MET:SD	2:H:465:ARG:HB3	2.38	0.64
2:H:487:LEU:HD23	2:H:489:GLU:H	1.63	0.64
2:B:349:LYS:NZ	2:B:407:GLY:O	2.25	0.63
2:E:349:LYS:NZ	2:E:407:GLY:O	2.25	0.63
2:H:349:LYS:NZ	2:H:407:GLY:O	2.25	0.63
1:A:88:LEU:HD23	1:A:102:PHE:CZ	2.32	0.63
1:D:88:LEU:HD21	1:D:126:SER:OG	1.99	0.63
2:E:14:VAL:O	2:E:18:ILE:HG23	1.98	0.63
1:D:368:SER:HB2	2:E:359:LEU:HD23	1.81	0.63
3:L:575:LEU:CD1	3:L:582:ILE:CD1	2.62	0.63
3:I:753:THR:HG22	3:I:754:ALA:N	2.14	0.63
2:E:487:LEU:CD2	2:E:489:GLU:H	2.11	0.63
3:C:415:ILE:HD11	3:C:453:ILE:HD13	1.80	0.63
3:I:554:LEU:CD1	3:I:557:LEU:HG	2.11	0.63
1:D:665:PHE:HB2	2:E:480:LEU:O	1.99	0.62
1:A:412:GLU:HG2	2:B:601:ASN:ND2	2.14	0.62
3:L:139:GLU:O	3:L:140:LEU:HG	1.99	0.62
3:C:753:THR:HG22	3:C:754:ALA:N	2.13	0.62
1:D:90:PHE:CE1	1:D:122:LYS:O	2.52	0.62
2:K:14:VAL:O	2:K:18:ILE:HG23	1.99	0.62
3:L:415:ILE:HD11	3:L:453:ILE:HD13	1.80	0.62
3:F:474:PRO:HB3	1:G:126:SER:CB	2.28	0.62
3:I:415:ILE:HD11	3:I:453:ILE:HD13	1.80	0.62
1:D:102:PHE:O	1:D:128:LYS:N	2.26	0.62
1:D:64:ILE:N	1:D:93:ASP:O	2.30	0.62
1:G:183:ILE:HD13	2:H:334:LEU:HD22	1.80	0.62
1:G:151:LEU:HD13	3:I:753:THR:OG1	1.99	0.62
1:A:477:VAL:HG12	1:A:478:PRO:N	2.15	0.61

*Continued on next page...*

*Continued from previous page...*

Atom-1	Atom-2	Interatomic distance (Å)	Clash overlap (Å)
3:I:554:LEU:HD13	3:I:557:LEU:H	1.65	0.61
1:D:52:TYR:CG	1:D:146:MET:HE1	2.34	0.61
3:F:757:ARG:O	3:F:758:ALA:HB3	1.99	0.61
3:I:549:PHE:CE1	3:I:569:GLU:OE1	2.53	0.61
2:B:487:LEU:CD1	2:B:488:PRO:CD	2.73	0.61
2:H:282:ALA:HB2	3:I:148:GLN:CG	2.30	0.61
2:B:363:ARG:HD3	3:F:139:GLU:OE2	1.99	0.61
3:F:474:PRO:HD3	1:G:126:SER:N	2.14	0.61
1:D:154:PHE:CG	3:F:715:CYS:O	2.53	0.61
3:I:554:LEU:HD11	3:I:557:LEU:CB	2.31	0.61
3:F:415:ILE:HD11	3:F:453:ILE:HD13	1.80	0.61
3:F:692:ARG:HH22	3:F:755:SER:CB	2.14	0.61
2:B:180:GLU:CB	1:G:203:PHE:HE1	2.13	0.61
1:G:531:THR:HG21	3:L:669:VAL:HG22	1.82	0.61
3:C:575:LEU:HD12	3:C:582:ILE:HD12	1.81	0.61
1:D:69:ARG:CD	1:D:91:LEU:HD13	2.31	0.61
1:G:67:ARG:NH2	3:I:770:ILE:HG22	2.16	0.61
1:J:477:VAL:HG12	1:J:478:PRO:N	2.15	0.61
1:G:477:VAL:HG12	1:G:478:PRO:N	2.16	0.61
2:E:487:LEU:HD23	2:E:489:GLU:H	1.66	0.60
1:D:52:TYR:CG	1:D:146:MET:CE	2.84	0.60
1:D:476:PRO:O	1:D:477:VAL:HG23	2.02	0.60
1:G:410:GLU:OE1	1:G:411:LEU:N	2.35	0.60
2:H:362:LYS:O	1:J:409:ASN:HB3	2.01	0.60
2:H:303:ASN:ND2	2:H:488:PRO:O	2.33	0.60
1:D:477:VAL:CG1	1:D:478:PRO:HD2	2.32	0.60
1:G:477:VAL:CG1	1:G:478:PRO:HD2	2.32	0.60
1:A:477:VAL:CG1	1:A:478:PRO:HD2	2.32	0.60
2:E:701:ILE:HD11	3:F:208:GLU:HA	1.83	0.60
1:A:171:ASN:ND2	2:B:167:GLU:OE2	2.35	0.60
1:A:396:THR:HG21	1:A:468:ARG:CG	2.31	0.59
1:A:73:VAL:CA	1:A:91:LEU:HD11	2.31	0.59
2:B:303:ASN:ND2	2:B:488:PRO:O	2.35	0.59
3:C:575:LEU:CD1	3:C:582:ILE:CD1	2.62	0.59
1:D:477:VAL:HG12	1:D:478:PRO:N	2.16	0.59
3:F:576:GLY:CA	3:F:583:PRO:HG3	2.25	0.59
1:G:476:PRO:O	1:G:477:VAL:HG23	2.02	0.59
1:D:410:GLU:OE1	1:D:411:LEU:N	2.35	0.59
1:D:48:PHE:HA	1:D:149:GLN:HE21	1.66	0.59
2:E:303:ASN:ND2	2:E:488:PRO:O	2.34	0.59
1:A:476:PRO:O	1:A:477:VAL:HG23	2.02	0.59

*Continued on next page...*

*Continued from previous page...*

Atom-1	Atom-2	Interatomic distance (Å)	Clash overlap (Å)
1:A:79:LEU:HG	1:A:95:PHE:CZ	2.37	0.59
1:A:575:MET:HG2	2:B:544:THR:HA	1.84	0.59
1:D:396:THR:HG21	1:D:468:ARG:CG	2.31	0.59
1:D:469:LYS:HB2	1:D:475:LEU:HD12	1.85	0.59
2:H:50:SER:HB3	2:H:68:PHE:CD1	2.37	0.59
1:J:476:PRO:O	1:J:477:VAL:HG23	2.02	0.59
1:A:368:SER:HB2	2:B:359:LEU:HD23	1.85	0.59
2:B:180:GLU:CD	2:B:215:LYS:HD3	2.17	0.59
3:F:358:ILE:C	3:F:423:PHE:C	2.61	0.59
1:D:562:ASP:HB2	3:F:49:LEU:HD13	1.83	0.59
2:H:363:ARG:HA	1:J:409:ASN:CB	2.33	0.59
1:D:64:ILE:HB	1:D:92:CYS:O	2.03	0.59
1:D:52:TYR:HE2	1:D:149:GLN:OE1	1.86	0.59
2:E:18:ILE:CD1	2:E:497:PHE:CG	2.86	0.59
1:D:199:VAL:O	2:E:67:LYS:HD2	2.03	0.59
1:G:176:PRO:HA	1:G:180:GLU:HB3	1.85	0.59
1:G:469:LYS:HB2	1:G:475:LEU:HD12	1.85	0.59
3:I:582:ILE:HG22	3:I:695:LEU:HD11	1.85	0.59
2:K:487:LEU:CD2	2:K:488:PRO:CD	2.81	0.59
1:D:185:MET:SD	2:E:173:ILE:CD1	2.91	0.58
2:H:363:ARG:CD	3:L:139:GLU:OE2	2.51	0.58
2:K:50:SER:HB3	2:K:68:PHE:CD1	2.37	0.58
1:A:366:LYS:HE2	2:B:359:LEU:CD1	2.27	0.58
2:B:50:SER:HB3	2:B:68:PHE:CD1	2.38	0.58
1:J:477:VAL:CG1	1:J:478:PRO:HD2	2.32	0.58
1:A:410:GLU:OE1	1:A:411:LEU:CB	2.48	0.58
2:H:15:THR:HA	2:H:18:ILE:HD12	1.85	0.58
2:K:303:ASN:ND2	2:K:488:PRO:O	2.35	0.58
3:F:474:PRO:HG3	1:G:126:SER:O	2.02	0.58
1:A:469:LYS:HB2	1:A:475:LEU:HD12	1.85	0.58
1:G:464:ARG:HG2	1:G:482:ASP:HB3	1.85	0.58
2:H:749:ALA:HB1	3:I:16:GLN:HA	1.86	0.58
2:H:51:ARG:CZ	2:H:82:THR:HG22	2.34	0.58
1:J:410:GLU:OE1	1:J:411:LEU:N	2.37	0.58
3:C:576:GLY:CA	3:C:583:PRO:HG3	2.28	0.58
1:D:151:LEU:HD11	3:F:751:LYS:HE3	1.85	0.58
2:K:18:ILE:CD1	2:K:497:PHE:CG	2.85	0.58
2:K:314:CYS:SG	2:K:477:ASN:ND2	2.76	0.58
1:J:464:ARG:HG2	1:J:482:ASP:HB3	1.86	0.58
1:D:165:ARG:NH2	2:E:707:ALA:HB2	2.19	0.58
1:D:194:LEU:HD21	2:E:220:LEU:HD11	1.84	0.58

*Continued on next page...*



*Continued from previous page...*

Atom-1	Atom-2	Interatomic distance (Å)	Clash overlap (Å)
3:F:755:SER:O	3:F:757:ARG:HG3	2.03	0.58
2:H:350:PHE:HB3	2:H:401:VAL:HG21	1.86	0.58
2:H:625:VAL:HG22	3:I:106:ASN:HB3	1.86	0.58
1:D:565:SER:OG	3:F:52:ARG:NH1	2.30	0.57
2:E:314:CYS:SG	2:E:477:ASN:ND2	2.76	0.57
2:H:314:CYS:SG	2:H:477:ASN:ND2	2.77	0.57
2:K:350:PHE:HB3	2:K:401:VAL:HG21	1.86	0.57
1:D:464:ARG:HG2	1:D:482:ASP:HB3	1.86	0.57
2:E:487:LEU:CD2	2:E:488:PRO:CD	2.81	0.57
2:E:50:SER:HB3	2:E:68:PHE:CD1	2.38	0.57
1:A:176:PRO:HA	1:A:180:GLU:HB3	1.85	0.57
1:A:72:ALA:O	1:A:91:LEU:CD2	2.50	0.57
2:H:662:PHE:CE2	3:I:102:ILE:HD13	2.40	0.57
3:I:42:ARG:CZ	3:I:50:ARG:HD2	2.35	0.57
1:J:469:LYS:HB2	1:J:475:LEU:HD12	1.85	0.57
2:H:487:LEU:HG	2:H:488:PRO:CD	2.32	0.57
3:I:393:LEU:N	3:I:417:CYS:SG	2.78	0.57
1:J:176:PRO:HA	1:J:180:GLU:HB3	1.85	0.57
2:B:18:ILE:HG21	2:B:497:PHE:CE1	2.40	0.57
2:H:686:GLN:OE1	3:I:39:THR:OG1	2.22	0.57
1:A:529:HIS:NE2	3:F:678:LYS:HG3	2.20	0.57
1:G:205:THR:OG1	1:G:208:GLN:HG3	2.04	0.57
2:H:286:THR:CG2	3:I:504:ASP:HB2	2.34	0.57
1:J:21:ALA:HA	1:J:38:ILE:HD11	1.87	0.57
1:D:90:PHE:HE1	1:D:122:LYS:O	1.88	0.57
1:D:410:GLU:CD	1:D:411:LEU:N	2.58	0.57
1:G:194:LEU:HG	2:H:348:ASN:HD22	1.69	0.57
3:F:474:PRO:CG	1:G:126:SER:CA	2.75	0.56
3:I:552:PRO:HG2	3:I:557:LEU:HD12	1.87	0.56
1:J:410:GLU:CD	1:J:411:LEU:N	2.59	0.56
2:B:314:CYS:SG	2:B:477:ASN:ND2	2.78	0.56
2:E:51:ARG:CZ	2:E:82:THR:HG22	2.34	0.56
2:B:363:ARG:HD2	3:F:139:GLU:OE2	2.02	0.56
1:G:410:GLU:CD	1:G:411:LEU:N	2.59	0.56
1:J:410:GLU:O	3:L:139:GLU:HB3	2.05	0.56
1:J:151:LEU:HD13	3:L:753:THR:CG2	2.35	0.56
2:B:15:THR:HA	2:B:18:ILE:HD12	1.86	0.56
1:A:322:ALA:HA	3:F:544:PHE:CG	2.40	0.56
2:B:350:PHE:HB3	2:B:401:VAL:HG21	1.87	0.56
3:F:393:LEU:N	3:F:417:CYS:SG	2.78	0.56
3:F:476:LYS:N	1:G:86:GLU:HG3	2.20	0.56

*Continued on next page...*

*Continued from previous page...*

Atom-1	Atom-2	Interatomic distance (Å)	Clash overlap (Å)
2:H:286:THR:HG23	3:I:504:ASP:HB2	1.87	0.56
2:K:487:LEU:HG	2:K:488:PRO:CD	2.32	0.56
2:K:51:ARG:CZ	2:K:82:THR:HG22	2.35	0.56
1:D:63:LEU:HA	1:D:94:ILE:HG12	1.87	0.56
1:A:21:ALA:HA	1:A:38:ILE:HD11	1.88	0.56
3:F:357:TYR:CD2	3:F:358:ILE:O	2.59	0.56
1:G:200:PRO:HB3	2:H:69:CYS:HB2	1.87	0.56
2:B:51:ARG:CZ	2:B:82:THR:HG22	2.34	0.56
3:L:393:LEU:N	3:L:417:CYS:SG	2.78	0.56
1:D:176:PRO:HA	1:D:180:GLU:HB3	1.86	0.56
3:C:393:LEU:N	3:C:417:CYS:SG	2.79	0.55
1:J:281:ARG:HD3	2:K:570:LYS:HB3	1.87	0.55
2:E:350:PHE:HB3	2:E:401:VAL:HG21	1.87	0.55
2:E:18:ILE:HD13	2:E:497:PHE:CG	2.42	0.55
2:H:18:ILE:HG21	2:H:497:PHE:CE1	2.41	0.55
3:I:39:THR:O	3:I:39:THR:HG22	2.07	0.55
1:A:635:ASN:ND2	2:B:27:PRO:O	2.40	0.55
1:G:203:PHE:HA	1:G:208:GLN:NE2	2.21	0.55
2:H:686:GLN:CD	3:I:39:THR:OG1	2.45	0.55
1:D:340:LEU:HD22	1:D:493:SER:HB3	1.88	0.55
1:D:90:PHE:CZ	1:D:122:LYS:CB	2.76	0.55
1:D:204:GLN:NE2	2:E:56:LYS:HE3	2.21	0.55
2:K:18:ILE:HD13	2:K:497:PHE:CG	2.41	0.55
1:G:175:LEU:HB3	1:G:176:PRO:HD2	1.89	0.55
1:A:28:TYR:HE1	1:A:69:ARG:HH11	1.52	0.55
1:G:637:SER:HB2	2:H:238:LEU:HA	1.87	0.55
1:D:575:MET:CG	2:E:544:THR:HA	2.36	0.55
2:E:123:SER:HB3	3:F:34:THR:HG22	1.88	0.55
3:F:140:LEU:O	3:F:248:ILE:HG22	2.07	0.55
3:F:753:THR:HG22	3:F:754:ALA:N	2.21	0.55
2:E:487:LEU:HG	2:E:488:PRO:CD	2.32	0.55
3:F:692:ARG:CZ	3:F:755:SER:OG	2.54	0.55
1:A:175:LEU:HB3	1:A:176:PRO:HD2	1.89	0.54
3:F:575:LEU:HD12	3:F:582:ILE:HD12	1.79	0.54
2:B:179:LYS:CB	1:G:203:PHE:HZ	2.20	0.54
3:L:140:LEU:O	3:L:248:ILE:HG22	2.07	0.54
2:H:487:LEU:CD2	2:H:488:PRO:CD	2.81	0.54
2:H:496:MET:HA	2:H:503:VAL:HG21	1.90	0.54
2:B:701:ILE:HD11	3:C:208:GLU:HA	1.89	0.54
1:D:52:TYR:CE2	1:D:146:MET:HB2	2.42	0.54
1:G:402:ALA:HB3	2:H:550:ARG:HG2	1.90	0.54

*Continued on next page...*

*Continued from previous page...*

Atom-1	Atom-2	Interatomic distance (Å)	Clash overlap (Å)
2:B:496:MET:HA	2:B:503:VAL:HG21	1.90	0.54
3:F:358:ILE:HG12	3:F:423:PHE:HA	1.90	0.54
1:A:529:HIS:NE2	3:F:678:LYS:HE2	2.23	0.54
1:J:410:GLU:HG2	3:L:137:TRP:HB3	1.89	0.54
1:D:52:TYR:CE2	1:D:146:MET:HE3	2.41	0.54
1:G:21:ALA:HA	1:G:38:ILE:HD11	1.88	0.54
1:J:408:ASP:O	1:J:412:GLU:CB	2.53	0.54
1:D:69:ARG:HE	1:D:91:LEU:CD2	2.20	0.54
1:D:175:LEU:HB3	1:D:176:PRO:HD2	1.90	0.54
1:D:185:MET:SD	2:E:173:ILE:HD13	2.48	0.54
2:H:686:GLN:OE1	3:I:39:THR:HG23	2.03	0.54
1:D:644:ASN:ND2	2:E:236:GLY:HA3	2.23	0.53
2:K:487:LEU:C	2:K:487:LEU:HD23	2.29	0.53
2:K:496:MET:HA	2:K:503:VAL:HG21	1.90	0.53
1:D:171:ASN:ND2	2:E:167:GLU:OE2	2.41	0.53
1:D:151:LEU:HD21	3:F:751:LYS:HG2	1.90	0.53
2:E:487:LEU:C	2:E:487:LEU:HD23	2.29	0.53
2:K:421:GLY:O	2:K:424:THR:OG1	2.24	0.53
1:A:67:ARG:HD3	1:A:71:THR:HG22	1.91	0.53
1:J:175:LEU:HB3	1:J:176:PRO:HD2	1.89	0.53
1:G:203:PHE:HB3	1:G:208:GLN:HB2	1.89	0.53
1:J:449:CYS:SG	1:J:490:LYS:NZ	2.81	0.53
1:J:412:GLU:OE1	2:K:601:ASN:ND2	2.42	0.53
2:E:496:MET:HA	2:E:503:VAL:HG21	1.90	0.53
3:I:554:LEU:C	3:I:554:LEU:HD12	2.29	0.53
1:D:245:LYS:HA	1:D:706:PHE:HB2	1.91	0.53
3:F:576:GLY:H	3:F:581:ASP:HB3	1.74	0.53
1:D:90:PHE:CG	1:D:123:LEU:HD11	2.41	0.52
2:B:182:LYS:HZ3	1:G:205:THR:HG23	1.68	0.52
1:G:476:PRO:O	1:G:477:VAL:CG2	2.57	0.52
2:B:487:LEU:HG	2:B:488:PRO:CD	2.38	0.52
1:A:568:ARG:HD2	2:B:555:GLU:OE2	2.08	0.52
1:D:281:ARG:HD3	2:E:570:LYS:HB3	1.89	0.52
1:J:476:PRO:O	1:J:477:VAL:CG2	2.57	0.52
1:J:680:ASN:H	1:J:680:ASN:ND2	2.06	0.52
2:K:487:LEU:CG	2:K:488:PRO:CD	2.88	0.52
1:A:476:PRO:O	1:A:477:VAL:CG2	2.57	0.52
1:A:86:GLU:O	1:A:88:LEU:HD22	2.10	0.52
1:D:69:ARG:NH1	1:D:91:LEU:CD1	2.62	0.52
2:E:421:GLY:O	2:E:424:THR:OG1	2.24	0.52
2:B:363:ARG:CZ	3:F:139:GLU:OE2	2.56	0.52

*Continued on next page...*

*Continued from previous page...*

Atom-1	Atom-2	Interatomic distance (Å)	Clash overlap (Å)
2:E:691:MET:SD	3:F:7:ILE:HG23	2.50	0.52
3:L:753:THR:CG2	3:L:754:ALA:N	2.73	0.52
1:D:476:PRO:O	1:D:477:VAL:CG2	2.57	0.52
1:J:355:LEU:HG	2:K:368:VAL:HG11	1.92	0.52
1:D:69:ARG:NE	1:D:91:LEU:HD21	2.22	0.52
3:F:477:MET:CE	1:G:126:SER:CB	2.87	0.52
2:H:750:ARG:HB2	3:I:15:CYS:HB2	1.92	0.52
1:D:155:SER:HA	3:F:714:VAL:CG2	2.40	0.52
2:H:357:ILE:O	2:H:370:ILE:HG22	2.10	0.52
1:J:245:LYS:HA	1:J:706:PHE:HB2	1.92	0.52
2:E:357:ILE:O	2:E:370:ILE:HG22	2.10	0.52
1:A:292:LYS:O	3:F:672:ASN:HB2	2.10	0.52
1:G:398:TRP:CG	1:G:433:ARG:HA	2.45	0.52
1:G:200:PRO:CB	2:H:69:CYS:HB2	2.40	0.52
3:I:138:LYS:HB3	3:I:250:GLU:HB2	1.92	0.52
2:K:373:GLU:HA	2:K:399:LYS:O	2.10	0.52
2:B:357:ILE:O	2:B:370:ILE:HG22	2.10	0.51
2:B:373:GLU:HA	2:B:399:LYS:O	2.10	0.51
2:B:487:LEU:CG	2:B:488:PRO:CD	2.88	0.51
1:G:303:LYS:HE2	3:L:123:LYS:HD3	1.91	0.51
2:E:373:GLU:HA	2:E:399:LYS:O	2.10	0.51
2:E:438:PHE:HB2	2:E:453:VAL:HB	1.92	0.51
2:E:702:ASN:HB2	3:F:171:MET:SD	2.50	0.51
2:H:624:ARG:HG2	3:I:109:GLY:O	2.10	0.51
1:A:245:LYS:HA	1:A:706:PHE:HB2	1.92	0.51
2:K:357:ILE:O	2:K:370:ILE:HG22	2.10	0.51
1:A:398:TRP:CG	1:A:433:ARG:HA	2.45	0.51
2:E:487:LEU:CG	2:E:488:PRO:CD	2.88	0.51
2:E:701:ILE:HD12	3:F:174:LEU:HD11	1.92	0.51
1:G:203:PHE:CA	1:G:208:GLN:NE2	2.74	0.51
3:L:139:GLU:O	3:L:140:LEU:CG	2.58	0.51
2:B:398:GLN:HG3	2:B:399:LYS:H	1.75	0.51
3:C:753:THR:CG2	3:C:754:ALA:N	2.73	0.51
1:G:245:LYS:HA	1:G:706:PHE:HB2	1.92	0.51
1:D:88:LEU:CD2	1:D:126:SER:OG	2.58	0.51
1:D:398:TRP:CG	1:D:433:ARG:HA	2.45	0.51
1:D:568:ARG:HB3	2:E:551:ILE:HD12	1.92	0.51
3:I:571:LEU:O	3:I:575:LEU:HG	2.11	0.51
3:I:711:GLY:O	3:I:753:THR:O	2.29	0.51
3:L:575:LEU:HD13	3:L:582:ILE:HG13	1.93	0.51
3:L:576:GLY:H	3:L:581:ASP:HB3	1.76	0.51

*Continued on next page...*

*Continued from previous page...*

Atom-1	Atom-2	Interatomic distance (Å)	Clash overlap (Å)
3:L:576:GLY:CA	3:L:583:PRO:HG3	2.26	0.51
1:A:407:ALA:CB	1:A:412:GLU:CB	2.70	0.51
1:G:449:CYS:SG	1:G:490:LYS:NZ	2.81	0.51
1:J:678:LEU:N	1:J:678:LEU:CD1	2.73	0.51
1:A:449:CYS:SG	1:A:490:LYS:NZ	2.82	0.51
1:D:13:LEU:HD21	1:D:39:GLY:O	2.11	0.51
1:D:449:CYS:SG	1:D:490:LYS:NZ	2.82	0.51
1:D:197:GLU:O	2:E:65:ARG:NH1	2.43	0.51
2:H:373:GLU:HA	2:H:399:LYS:O	2.10	0.51
1:G:624:GLN:NE2	2:H:8:MET:SD	2.80	0.51
1:J:398:TRP:CG	1:J:433:ARG:HA	2.45	0.51
2:B:438:PHE:HB2	2:B:453:VAL:HB	1.93	0.51
1:D:112:ASP:HB2	1:D:139:ASP:HB2	1.92	0.51
1:D:419:ASN:ND2	2:E:543:SER:OG	2.42	0.51
2:H:746:ALA:HB1	3:I:15:CYS:SG	2.50	0.51
3:I:753:THR:CG2	3:I:754:ALA:N	2.73	0.51
1:J:469:LYS:HD3	1:J:475:LEU:CD1	2.40	0.51
1:J:59:ASP:OD2	3:L:769:LYS:NZ	2.44	0.51
2:H:303:ASN:ND2	2:H:488:PRO:HA	2.27	0.50
1:A:677:CYS:HA	2:B:238:LEU:HD22	1.93	0.50
3:C:138:LYS:HB3	3:C:250:GLU:HB2	1.92	0.50
2:E:398:GLN:HG3	2:E:399:LYS:H	1.76	0.50
2:E:18:ILE:HD13	2:E:497:PHE:CD1	2.38	0.50
1:G:264:LEU:HD21	1:G:267:GLU:HB2	1.94	0.50
1:G:469:LYS:CD	1:G:475:LEU:HD13	2.40	0.50
3:C:571:LEU:O	3:C:575:LEU:HG	2.11	0.50
3:C:576:GLY:H	3:C:581:ASP:HB3	1.77	0.50
1:D:264:LEU:HD21	1:D:267:GLU:HB2	1.93	0.50
2:H:90:LEU:HA	2:H:93:LEU:HD12	1.93	0.50
1:J:402:ALA:HB3	2:K:550:ARG:HG2	1.93	0.50
3:I:577:THR:HA	3:I:754:ALA:HA	1.92	0.50
2:B:90:LEU:HA	2:B:93:LEU:HD12	1.93	0.50
2:E:282:ALA:CB	3:F:149:ARG:HD3	2.40	0.50
3:I:57:SER:HB2	3:I:60:PRO:HG3	1.94	0.50
1:A:264:LEU:HD21	1:A:267:GLU:HB2	1.93	0.50
3:F:575:LEU:HD13	3:F:582:ILE:HG13	1.93	0.50
1:J:264:LEU:HD21	1:J:267:GLU:HB2	1.93	0.50
2:K:342:ALA:HB3	2:K:343:PRO:HD3	1.94	0.50
2:B:421:GLY:O	2:B:424:THR:OG1	2.24	0.50
2:H:359:LEU:HB2	2:H:368:VAL:HB	1.94	0.50
3:L:122:TYR:CD1	3:L:213:MET:HG2	2.47	0.50

*Continued on next page...*

*Continued from previous page...*

Atom-1	Atom-2	Interatomic distance (Å)	Clash overlap (Å)
2:K:90:LEU:HA	2:K:93:LEU:HD12	1.94	0.49
3:L:138:LYS:HD3	3:L:250:GLU:HG2	1.93	0.49
3:C:230:ALA:HB1	3:C:235:ARG:HD2	1.94	0.49
3:L:230:ALA:HB1	3:L:235:ARG:HD2	1.95	0.49
3:L:57:SER:HB2	3:L:60:PRO:HG3	1.94	0.49
1:D:200:PRO:HG3	2:E:318:GLU:HB3	1.93	0.49
1:D:69:ARG:NE	1:D:91:LEU:CD2	2.75	0.49
3:F:358:ILE:CA	3:F:423:PHE:CA	2.82	0.49
2:H:686:GLN:CD	3:I:39:THR:HG1	2.16	0.49
3:L:138:LYS:HE2	3:L:140:LEU:CD1	2.43	0.49
1:D:165:ARG:HD3	2:E:706:GLY:CA	2.42	0.49
1:D:405:PRO:HG2	2:E:601:ASN:ND2	2.28	0.49
3:I:575:LEU:HD12	3:I:582:ILE:HD12	1.77	0.49
3:C:57:SER:HB2	3:C:60:PRO:HG3	1.94	0.49
3:C:565:THR:HG22	3:C:685:TYR:HB3	1.95	0.49
2:H:279:GLU:HB2	3:I:224:PHE:CE2	2.47	0.49
2:H:487:LEU:C	2:H:487:LEU:HD23	2.29	0.49
1:A:631:PHE:CD1	2:B:23:PRO:HB3	2.48	0.49
3:C:122:TYR:CD1	3:C:213:MET:HG2	2.48	0.49
3:F:57:SER:HB2	3:F:60:PRO:HG3	1.94	0.49
2:K:438:PHE:HB2	2:K:453:VAL:HB	1.93	0.49
3:L:571:LEU:O	3:L:575:LEU:HG	2.12	0.49
1:D:233:ASN:HA	2:E:78:LEU:CG	2.42	0.49
3:F:138:LYS:HE2	3:F:140:LEU:CD1	2.43	0.49
2:H:487:LEU:CG	2:H:488:PRO:CD	2.88	0.49
3:I:575:LEU:HD13	3:I:582:ILE:CB	2.43	0.49
3:L:711:GLY:O	3:L:753:THR:O	2.30	0.49
3:L:721:ALA:HB1	3:L:738:VAL:HA	1.94	0.49
1:D:79:LEU:HG	1:D:95:PHE:CE1	2.48	0.49
3:F:122:TYR:CD1	3:F:213:MET:HG2	2.47	0.49
3:F:571:LEU:O	3:F:575:LEU:HG	2.12	0.49
3:F:757:ARG:O	3:F:758:ALA:CB	2.61	0.49
1:G:203:PHE:HA	1:G:208:GLN:HE22	1.78	0.49
2:H:134:TRP:HZ3	2:H:183:PHE:CE1	2.31	0.49
1:G:648:LYS:HE3	2:H:482:LYS:O	2.13	0.49
2:K:134:TRP:HZ3	2:K:183:PHE:CE1	2.30	0.49
2:B:282:ALA:HB3	3:C:149:ARG:HD3	1.94	0.49
1:D:150:LYS:HD3	3:F:716:GLU:OE2	2.12	0.49
1:A:345:ARG:HH11	3:F:136:MET:HB3	1.78	0.49
3:F:565:THR:HG22	3:F:685:TYR:HB3	1.94	0.49
2:H:398:GLN:HG3	2:H:399:LYS:H	1.78	0.49

*Continued on next page...*

*Continued from previous page...*

Atom-1	Atom-2	Interatomic distance (Å)	Clash overlap (Å)
2:K:359:LEU:HB2	2:K:368:VAL:HB	1.94	0.49
2:K:398:GLN:HG3	2:K:399:LYS:H	1.77	0.49
3:C:721:ALA:HB1	3:C:738:VAL:HA	1.94	0.49
3:F:230:ALA:HB1	3:F:235:ARG:HD2	1.94	0.49
3:I:552:PRO:CD	3:I:557:LEU:HD12	2.43	0.49
1:J:240:HIS:NE2	1:J:656:ASP:OD2	2.46	0.49
1:J:695:VAL:HG13	1:J:705:PHE:CD1	2.48	0.49
1:G:112:ASP:HB2	1:G:139:ASP:HB2	1.95	0.48
3:I:230:ALA:HB1	3:I:235:ARG:HD2	1.95	0.48
1:D:92:CYS:SG	1:D:102:PHE:CD2	2.81	0.48
2:H:438:PHE:HB2	2:H:453:VAL:HB	1.94	0.48
2:E:90:LEU:HA	2:E:93:LEU:HD12	1.95	0.48
1:J:238:ILE:HG21	1:J:665:PHE:HA	1.95	0.48
3:L:139:GLU:O	3:L:140:LEU:HD23	2.13	0.48
1:A:695:VAL:HG13	1:A:705:PHE:CD1	2.48	0.48
1:D:473:GLU:OE2	1:D:475:LEU:HD21	2.13	0.48
3:F:357:TYR:CE2	3:F:358:ILE:O	2.65	0.48
3:F:721:ALA:HB1	3:F:738:VAL:HA	1.94	0.48
2:B:180:GLU:HG3	1:G:203:PHE:CD1	2.47	0.48
3:I:721:ALA:HB1	3:I:738:VAL:HA	1.94	0.48
1:J:677:CYS:SG	1:J:678:LEU:HD12	2.54	0.48
2:K:303:ASN:ND2	2:K:488:PRO:HA	2.28	0.48
2:B:303:ASN:ND2	2:B:488:PRO:HA	2.29	0.48
1:D:233:ASN:HA	2:E:78:LEU:CD1	2.43	0.48
1:D:240:HIS:NE2	1:D:656:ASP:OD2	2.46	0.48
1:G:477:VAL:CG1	1:G:478:PRO:CD	2.92	0.48
1:G:240:HIS:NE2	1:G:656:ASP:OD2	2.47	0.48
2:H:282:ALA:HB3	3:I:149:ARG:HD3	1.96	0.48
1:J:477:VAL:CG1	1:J:478:PRO:CD	2.92	0.48
1:J:477:VAL:CG1	1:J:478:PRO:N	2.77	0.48
1:J:183:ILE:HD13	2:K:334:LEU:HD13	1.94	0.48
1:A:240:HIS:NE2	1:A:656:ASP:OD2	2.46	0.48
2:B:342:ALA:HB3	2:B:343:PRO:HD3	1.95	0.48
2:E:359:LEU:HB2	2:E:368:VAL:HB	1.95	0.48
1:G:201:LEU:HD11	2:H:87:ILE:HD11	1.96	0.48
3:I:122:TYR:CD1	3:I:213:MET:HG2	2.47	0.48
2:H:743:ILE:HD12	3:I:8:ALA:HB1	1.95	0.48
1:A:469:LYS:CD	1:A:475:LEU:HD13	2.40	0.48
1:A:473:GLU:OE2	1:A:475:LEU:HD21	2.14	0.48
1:A:67:ARG:HG2	1:A:71:THR:HB	1.94	0.48
2:B:359:LEU:HB2	2:B:368:VAL:HB	1.94	0.48

*Continued on next page...*

*Continued from previous page...*

Atom-1	Atom-2	Interatomic distance (Å)	Clash overlap (Å)
1:D:238:ILE:HG21	1:D:665:PHE:HA	1.95	0.48
1:G:473:GLU:OE2	1:G:475:LEU:HD21	2.14	0.48
1:J:473:GLU:OE2	1:J:475:LEU:HD21	2.14	0.48
1:A:112:ASP:HB2	1:A:139:ASP:HB2	1.95	0.48
1:A:115:TYR:CZ	1:A:175:LEU:HD12	2.48	0.48
1:A:632:CYS:HA	2:B:26:GLY:HA3	1.95	0.48
1:D:52:TYR:CD2	1:D:146:MET:CE	2.96	0.48
1:D:583:LEU:HD13	3:F:247:TRP:CZ2	2.49	0.48
1:D:69:ARG:NH2	1:D:91:LEU:CD1	2.70	0.48
3:F:139:GLU:O	3:F:140:LEU:HG	2.14	0.48
3:F:475:GLY:C	1:G:86:GLU:CG	2.81	0.48
1:G:535:LYS:NZ	3:L:654:GLU:HG2	2.29	0.48
1:D:151:LEU:CD2	3:F:751:LYS:HG2	2.44	0.48
3:F:474:PRO:HG3	1:G:126:SER:C	2.33	0.48
2:H:342:ALA:HB3	2:H:343:PRO:HD3	1.95	0.48
3:L:565:THR:HG22	3:L:685:TYR:HB3	1.95	0.48
3:C:711:GLY:O	3:C:753:THR:O	2.31	0.48
1:D:677:CYS:HA	2:E:238:LEU:HD22	1.96	0.48
1:G:203:PHE:HB3	1:G:208:GLN:CB	2.44	0.48
1:G:191:PHE:CE1	2:H:344:VAL:HG21	2.49	0.48
2:B:18:ILE:HD13	2:B:497:PHE:CG	2.49	0.47
3:C:576:GLY:HA2	3:C:583:PRO:HD3	1.95	0.47
2:E:627:ASN:ND2	3:F:111:CYS:SG	2.87	0.47
3:F:711:GLY:O	3:F:753:THR:O	2.32	0.47
1:G:115:TYR:CZ	1:G:175:LEU:HD12	2.48	0.47
1:G:695:VAL:HG13	1:G:705:PHE:CD1	2.48	0.47
1:J:151:LEU:HD13	3:L:753:THR:OG1	2.14	0.47
3:L:138:LYS:HD3	3:L:250:GLU:CG	2.44	0.47
3:L:692:ARG:CZ	3:L:755:SER:OG	2.60	0.47
1:A:73:VAL:N	1:A:91:LEU:HD11	2.29	0.47
1:D:155:SER:HA	3:F:714:VAL:HG23	1.96	0.47
1:D:477:VAL:CG1	1:D:478:PRO:CD	2.92	0.47
1:G:151:LEU:HA	3:I:714:VAL:O	2.15	0.47
1:G:477:VAL:CG1	1:G:478:PRO:N	2.77	0.47
2:H:18:ILE:HD13	2:H:497:PHE:CG	2.49	0.47
2:E:342:ALA:HB3	2:E:343:PRO:HD3	1.94	0.47
2:E:303:ASN:ND2	2:E:488:PRO:HA	2.30	0.47
2:H:289:THR:HG21	3:I:499:GLN:HE22	1.79	0.47
1:A:477:VAL:CG1	1:A:478:PRO:CD	2.91	0.47
1:D:695:VAL:HG13	1:D:705:PHE:CD1	2.49	0.47
1:D:660:LYS:HE2	2:E:489:GLU:HB2	1.97	0.47

*Continued on next page...*



*Continued from previous page...*

Atom-1	Atom-2	Interatomic distance (Å)	Clash overlap (Å)
1:J:115:TYR:CZ	1:J:175:LEU:HD12	2.49	0.47
1:J:677:CYS:C	1:J:678:LEU:HD12	2.34	0.47
1:A:238:ILE:HG21	1:A:665:PHE:HA	1.96	0.47
3:F:166:ILE:HD12	3:F:218:PHE:HB2	1.95	0.47
3:F:138:LYS:HD3	3:F:250:GLU:HG2	1.97	0.47
3:F:474:PRO:HD3	1:G:125:ASN:C	2.35	0.47
2:B:180:GLU:OE2	2:B:215:LYS:HE2	2.14	0.47
3:I:565:THR:HG22	3:I:685:TYR:HB3	1.95	0.47
1:J:287:ILE:CG2	1:J:460:PRO:HB3	2.45	0.47
3:L:166:ILE:HD12	3:L:218:PHE:HB2	1.96	0.47
1:A:477:VAL:CG1	1:A:478:PRO:N	2.77	0.47
1:D:13:LEU:HG	1:D:43:GLN:OE1	2.15	0.47
3:F:139:GLU:O	3:F:140:LEU:HD23	2.14	0.47
3:F:577:THR:HG23	3:F:754:ALA:CA	2.43	0.47
1:G:338:GLU:HG2	3:L:254:ALA:HB1	1.96	0.47
3:C:692:ARG:CZ	3:C:755:SER:OG	2.62	0.47
1:D:287:ILE:CG2	1:D:460:PRO:HB3	2.45	0.47
2:E:134:TRP:HZ3	2:E:183:PHE:CE1	2.32	0.47
2:B:179:LYS:HB2	1:G:203:PHE:CE1	2.49	0.47
1:G:287:ILE:CG2	1:G:460:PRO:HB3	2.45	0.47
1:D:165:ARG:HD3	2:E:706:GLY:HA2	1.97	0.47
3:F:474:PRO:HG3	1:G:126:SER:CA	2.42	0.47
1:J:10:GLU:HB2	3:L:330:GLN:HE22	1.79	0.47
1:A:88:LEU:HD23	1:A:102:PHE:CE2	2.50	0.46
1:D:410:GLU:CB	3:F:137:TRP:HB3	2.34	0.46
1:J:235:LYS:NZ	2:K:464:ILE:HG22	2.30	0.46
1:J:407:ALA:CB	1:J:412:GLU:HB3	2.46	0.46
2:E:697:GLU:N	3:F:178:GLU:OE2	2.49	0.46
1:D:233:ASN:CG	2:E:78:LEU:HD12	2.35	0.46
3:F:754:ALA:O	3:F:755:SER:C	2.50	0.46
1:J:112:ASP:HB2	1:J:139:ASP:HB2	1.95	0.46
1:J:407:ALA:HA	1:J:412:GLU:HG3	1.97	0.46
1:A:287:ILE:CG2	1:A:460:PRO:HB3	2.45	0.46
1:A:278:GLU:HG2	2:B:570:LYS:HD2	1.96	0.46
2:E:14:VAL:HG12	2:E:18:ILE:HG22	1.96	0.46
1:D:635:ASN:ND2	2:E:27:PRO:O	2.48	0.46
3:F:576:GLY:HA2	3:F:583:PRO:HD3	1.92	0.46
1:G:291:LYS:HD3	1:G:324:ILE:HG22	1.97	0.46
1:J:624:GLN:NE2	2:K:8:MET:SD	2.84	0.46
2:B:439:TRP:HB2	2:B:450:LEU:HD11	1.98	0.46
1:A:401:MET:CE	2:B:551:ILE:HD11	2.44	0.46

*Continued on next page...*

*Continued from previous page...*

Atom-1	Atom-2	Interatomic distance (Å)	Clash overlap (Å)
1:D:291:LYS:HD3	1:D:324:ILE:HG22	1.97	0.46
2:E:18:ILE:HD13	2:E:497:PHE:HB2	1.97	0.46
1:G:183:ILE:HD13	2:H:334:LEU:CD2	2.46	0.46
1:G:200:PRO:HB3	2:H:69:CYS:SG	2.55	0.46
3:I:453:ILE:HG12	3:I:463:LEU:HD22	1.97	0.46
3:I:575:LEU:HD13	3:I:582:ILE:HB	1.97	0.46
2:K:18:ILE:HD13	2:K:497:PHE:HB2	1.97	0.46
1:A:291:LYS:HD3	1:A:324:ILE:HG22	1.98	0.46
1:G:238:ILE:HG21	1:G:665:PHE:HA	1.96	0.46
1:G:469:LYS:HD3	1:G:475:LEU:CD1	2.40	0.46
2:H:363:ARG:CG	1:J:409:ASN:HB2	2.33	0.46
1:D:469:LYS:HD3	1:D:475:LEU:CD1	2.40	0.46
1:D:477:VAL:CG1	1:D:478:PRO:N	2.78	0.46
3:F:681:SER:HB3	3:F:691:ILE:HD11	1.98	0.46
2:H:289:THR:HG21	3:I:499:GLN:OE1	2.16	0.46
3:I:283:ASN:O	3:I:287:LYS:NZ	2.46	0.46
1:A:287:ILE:HA	1:A:290:PHE:HB2	1.98	0.46
1:D:287:ILE:HA	1:D:290:PHE:HB2	1.98	0.46
1:G:242:GLU:OE1	1:G:242:GLU:N	2.48	0.46
2:K:439:TRP:HB2	2:K:450:LEU:HD11	1.98	0.46
2:B:134:TRP:HZ3	2:B:183:PHE:CE1	2.32	0.46
1:D:242:GLU:N	1:D:242:GLU:OE1	2.49	0.46
2:E:439:TRP:HB2	2:E:450:LEU:HD11	1.98	0.46
1:A:348:LYS:NZ	3:F:138:LYS:NZ	2.63	0.46
1:A:88:LEU:C	1:A:90:PHE:N	2.66	0.46
3:C:166:ILE:HD12	3:C:218:PHE:HB2	1.96	0.46
1:D:69:ARG:HD3	1:D:91:LEU:CD1	2.46	0.46
2:H:439:TRP:HB2	2:H:450:LEU:HD11	1.98	0.46
3:I:166:ILE:HD12	3:I:218:PHE:HB2	1.97	0.46
1:D:17:ALA:HA	1:D:42:PHE:HE2	1.81	0.46
1:G:194:LEU:HG	2:H:348:ASN:ND2	2.29	0.46
2:H:421:GLY:O	2:H:424:THR:OG1	2.24	0.46
1:J:287:ILE:HA	1:J:290:PHE:HB2	1.98	0.46
1:J:201:LEU:HD21	2:K:87:ILE:HD11	1.98	0.46
3:L:393:LEU:HD22	3:L:396:ILE:HD11	1.98	0.45
1:D:14:GLU:HG2	1:D:43:GLN:NE2	2.31	0.45
1:D:190:THR:HG21	2:E:216:HIS:CE1	2.50	0.45
3:F:59:PHE:N	3:F:60:PRO:HD3	2.31	0.45
3:I:59:PHE:N	3:I:60:PRO:HD3	2.32	0.45
1:J:405:PRO:HG2	2:K:601:ASN:ND2	2.32	0.45
2:K:14:VAL:HG12	2:K:18:ILE:HG22	1.98	0.45

*Continued on next page...*

*Continued from previous page...*

Atom-1	Atom-2	Interatomic distance (Å)	Clash overlap (Å)
3:L:576:GLY:HA2	3:L:583:PRO:HD3	1.94	0.45
1:A:174:PHE:HB2	1:A:179:GLU:HB2	1.98	0.45
3:C:59:PHE:N	3:C:60:PRO:HD3	2.32	0.45
1:A:529:HIS:NE2	3:F:678:LYS:CE	2.79	0.45
1:G:209:MET:SD	1:G:209:MET:C	2.94	0.45
1:A:23:GLU:OE1	1:A:68:LYS:CD	2.63	0.45
1:D:355:LEU:HD13	1:D:359:VAL:HG23	1.99	0.45
1:D:655:GLY:HA2	2:E:490:LEU:HD12	1.98	0.45
3:F:474:PRO:CB	1:G:126:SER:CA	2.87	0.45
3:L:577:THR:HG23	3:L:754:ALA:HB2	1.97	0.45
1:J:174:PHE:HB2	1:J:179:GLU:HB2	1.98	0.45
2:H:691:MET:HG2	3:I:10:GLU:HG2	1.98	0.45
1:G:558:LYS:HE3	3:I:49:LEU:HD11	1.98	0.45
1:J:151:LEU:HD13	3:L:753:THR:HG21	1.99	0.45
1:J:291:LYS:HD3	1:J:324:ILE:HG22	1.97	0.45
3:L:681:SER:HB3	3:L:691:ILE:HD11	1.98	0.45
3:C:283:ASN:O	3:C:287:LYS:NZ	2.45	0.45
3:C:453:ILE:HG12	3:C:463:LEU:HD22	1.98	0.45
3:C:681:SER:HB3	3:C:691:ILE:HD11	1.98	0.45
3:F:753:THR:CG2	3:F:754:ALA:N	2.79	0.45
1:G:174:PHE:HB2	1:G:179:GLU:HB2	1.98	0.45
2:H:50:SER:HB3	2:H:68:PHE:CE2	2.52	0.45
2:H:631:PRO:HB3	3:I:68:LEU:HB2	1.99	0.45
1:J:242:GLU:OE1	1:J:242:GLU:N	2.49	0.45
3:L:59:PHE:N	3:L:60:PRO:HD3	2.32	0.45
1:G:287:ILE:HA	1:G:290:PHE:HB2	1.98	0.45
1:G:405:PRO:HG2	2:H:601:ASN:ND2	2.32	0.45
3:I:393:LEU:HD22	3:I:396:ILE:HD11	1.98	0.45
3:L:139:GLU:O	3:L:140:LEU:CD2	2.64	0.45
1:A:242:GLU:N	1:A:242:GLU:OE1	2.50	0.45
1:A:469:LYS:HB2	1:A:475:LEU:CD1	2.47	0.45
1:A:418:LEU:HB3	2:B:543:SER:OG	2.17	0.45
1:D:151:LEU:O	3:F:714:VAL:O	2.34	0.45
2:H:427:TYR:CD2	2:H:431:GLU:HB2	2.52	0.45
2:K:131:THR:HG21	2:K:251:ARG:HD2	1.99	0.45
3:L:138:LYS:HE2	3:L:140:LEU:HD11	1.99	0.45
1:D:152:ARG:NH1	3:F:762:ASP:OD2	2.50	0.45
1:G:469:LYS:HB2	1:G:475:LEU:CD1	2.47	0.45
1:G:8:ILE:HD11	2:H:115:THR:CG2	2.47	0.45
2:H:131:THR:HG21	2:H:251:ARG:HD2	1.99	0.45
1:A:338:GLU:CG	3:F:254:ALA:HB1	2.43	0.44

*Continued on next page...*

*Continued from previous page...*

Atom-1	Atom-2	Interatomic distance (Å)	Clash overlap (Å)
3:F:453:ILE:HG12	3:F:463:LEU:HD22	1.98	0.44
3:I:692:ARG:CZ	3:I:755:SER:OG	2.61	0.44
1:J:660:LYS:HE2	2:K:489:GLU:OE2	2.17	0.44
2:B:50:SER:HB3	2:B:68:PHE:CE2	2.52	0.44
1:D:434:GLU:HA	1:D:437:LYS:HG2	2.00	0.44
1:D:488:CYS:SG	1:D:504:ILE:HD11	2.58	0.44
3:F:393:LEU:HD22	3:F:396:ILE:HD11	1.98	0.44
2:K:542:PRO:HD3	3:L:247:TRP:CZ2	2.52	0.44
1:D:140:LYS:HE2	1:D:145:PRO:HD2	2.00	0.44
1:D:657:LYS:HE3	2:E:9:PHE:O	2.17	0.44
1:J:88:LEU:HD12	1:J:123:LEU:HD22	1.99	0.44
2:K:467:PHE:O	2:K:470:VAL:HG12	2.17	0.44
1:A:469:LYS:HD3	1:A:475:LEU:CD1	2.40	0.44
3:C:393:LEU:HD21	3:C:467:ARG:CZ	2.48	0.44
3:C:577:THR:HG23	3:C:754:ALA:HB2	1.99	0.44
3:F:477:MET:CE	1:G:126:SER:OG	2.65	0.44
1:A:577:THR:HG21	2:B:20:THR:CG2	2.47	0.44
1:G:434:GLU:HA	1:G:437:LYS:HG2	1.99	0.44
1:J:223:LEU:HD22	2:K:432:LEU:HD23	1.99	0.44
1:A:410:GLU:OE1	1:A:411:LEU:N	2.50	0.44
2:B:68:PHE:CD1	2:B:68:PHE:O	2.71	0.44
2:E:50:SER:HB3	2:E:68:PHE:CE2	2.52	0.44
1:J:355:LEU:HD13	1:J:359:VAL:HG23	1.99	0.44
1:J:469:LYS:HB2	1:J:475:LEU:CD1	2.48	0.44
2:K:50:SER:HB3	2:K:68:PHE:CE2	2.52	0.44
2:B:627:ASN:ND2	3:C:111:CYS:SG	2.91	0.44
2:E:467:PHE:O	2:E:470:VAL:HG12	2.18	0.44
1:G:338:GLU:HG2	3:L:254:ALA:CB	2.48	0.44
1:J:364:GLY:O	2:K:361:ASN:HB3	2.17	0.44
3:L:139:GLU:OE1	3:L:139:GLU:N	2.51	0.44
1:A:355:LEU:HD13	1:A:359:VAL:HG23	1.99	0.44
1:A:488:CYS:SG	1:A:504:ILE:HD11	2.58	0.44
3:F:138:LYS:HE2	3:F:140:LEU:HD11	2.00	0.44
3:L:453:ILE:HG12	3:L:463:LEU:HD22	1.98	0.44
1:A:76:GLN:NE2	1:A:90:PHE:O	2.51	0.44
2:B:427:TYR:CD2	2:B:431:GLU:HB2	2.53	0.44
3:C:575:LEU:HD13	3:C:582:ILE:HG13	1.96	0.44
1:D:469:LYS:CD	1:D:475:LEU:HD13	2.41	0.44
3:F:477:MET:CE	1:G:126:SER:HB2	2.47	0.44
1:G:203:PHE:CB	1:G:208:GLN:NE2	2.76	0.44
1:G:355:LEU:HD13	1:G:359:VAL:HG23	1.99	0.44

*Continued on next page...*

*Continued from previous page...*

Atom-1	Atom-2	Interatomic distance (Å)	Clash overlap (Å)
1:G:352:GLU:HG3	2:H:370:ILE:CD1	2.47	0.44
2:H:746:ALA:HB2	3:I:12:LYS:HA	2.00	0.44
1:J:407:ALA:HB1	1:J:412:GLU:HB3	1.99	0.44
1:A:321:LYS:HB3	3:F:544:PHE:CZ	2.53	0.43
1:G:488:CYS:SG	1:G:504:ILE:HD11	2.57	0.43
1:G:49:CYS:HB2	1:G:61:PHE:HB2	2.00	0.43
3:I:393:LEU:HD21	3:I:467:ARG:CZ	2.48	0.43
1:J:434:GLU:HA	1:J:437:LYS:HG2	2.00	0.43
1:J:488:CYS:SG	1:J:504:ILE:HD11	2.58	0.43
1:D:69:ARG:HD3	1:D:91:LEU:HD13	1.99	0.43
1:G:223:LEU:HD22	2:H:432:LEU:HD23	2.00	0.43
2:H:467:PHE:O	2:H:470:VAL:HG12	2.18	0.43
1:A:434:GLU:HA	1:A:437:LYS:HG2	2.01	0.43
1:A:286:LEU:CD1	1:A:482:ASP:OD2	2.60	0.43
1:A:405:PRO:HB3	2:B:598:LEU:HG	1.99	0.43
1:D:51:GLU:N	1:D:51:GLU:OE1	2.51	0.43
2:E:427:TYR:CD2	2:E:431:GLU:HB2	2.53	0.43
3:L:393:LEU:HD21	3:L:467:ARG:CZ	2.48	0.43
1:A:51:GLU:N	1:A:51:GLU:OE1	2.51	0.43
2:B:363:ARG:NH2	3:F:139:GLU:CD	2.67	0.43
3:C:393:LEU:HD22	3:C:396:ILE:HD11	1.99	0.43
1:D:64:ILE:HG22	1:D:72:ALA:HB1	2.00	0.43
1:G:207:GLU:HA	1:G:207:GLU:OE1	2.18	0.43
1:A:49:CYS:HB2	1:A:61:PHE:HB2	2.00	0.43
3:C:322:LEU:HD21	3:C:531:ALA:HB1	2.01	0.43
2:H:68:PHE:CD1	2:H:68:PHE:O	2.71	0.43
2:H:664:THR:HG23	3:I:42:ARG:HD3	2.00	0.43
2:K:265:CYS:HB3	2:K:274:PRO:HG3	2.01	0.43
2:B:131:THR:HG21	2:B:251:ARG:HD2	2.00	0.43
3:F:172:TRP:CD1	3:F:186:ILE:HD11	2.54	0.43
1:G:303:LYS:CE	3:L:123:LYS:HD3	2.49	0.43
3:I:552:PRO:CD	3:I:557:LEU:CD1	2.96	0.43
1:J:51:GLU:N	1:J:51:GLU:OE1	2.51	0.43
1:A:140:LYS:HE2	1:A:145:PRO:HD2	2.00	0.43
1:A:577:THR:HG21	2:B:20:THR:HG21	2.00	0.43
2:E:131:THR:HG21	2:E:251:ARG:HD2	2.00	0.43
2:E:68:PHE:O	2:E:68:PHE:CD1	2.72	0.43
2:E:705:ILE:H	3:F:744:GLN:HB2	1.84	0.43
3:F:357:TYR:O	3:F:423:PHE:HB3	2.19	0.43
3:F:393:LEU:HD21	3:F:467:ARG:CZ	2.48	0.43
2:H:265:CYS:HB3	2:H:274:PRO:HG3	2.01	0.43

*Continued on next page...*

*Continued from previous page...*

Atom-1	Atom-2	Interatomic distance (Å)	Clash overlap (Å)
2:H:705:ILE:O	3:I:744:GLN:HB2	2.18	0.43
1:J:265:MET:HG2	1:J:434:GLU:HG2	2.00	0.43
1:J:49:CYS:HB2	1:J:61:PHE:HB2	2.00	0.43
1:A:399:VAL:HB	1:A:427:GLN:HE22	1.84	0.43
1:D:399:VAL:HB	1:D:427:GLN:HE22	1.84	0.43
2:H:746:ALA:CB	3:I:12:LYS:HA	2.49	0.43
3:L:138:LYS:CB	3:L:250:GLU:HB2	2.42	0.43
2:B:467:PHE:O	2:B:470:VAL:HG12	2.18	0.43
2:B:79:VAL:HB	2:B:480:LEU:HD11	2.01	0.43
3:C:444:PRO:O	3:C:448:VAL:HG23	2.19	0.43
2:E:577:ILE:HA	2:E:580:PHE:HB3	2.01	0.43
1:G:402:ALA:O	2:H:550:ARG:HD3	2.19	0.43
1:J:399:VAL:HB	1:J:427:GLN:HE22	1.84	0.43
1:A:265:MET:HG2	1:A:434:GLU:HG2	2.01	0.43
3:F:139:GLU:OE1	3:F:139:GLU:N	2.51	0.43
1:G:51:GLU:N	1:G:51:GLU:OE1	2.52	0.43
1:G:67:ARG:CZ	3:I:770:ILE:HG22	2.48	0.43
1:G:410:GLU:HG2	3:I:137:TRP:HB3	1.99	0.43
3:I:172:TRP:CD1	3:I:186:ILE:HD11	2.54	0.43
2:H:536:ILE:CG1	3:I:240:HIS:HB3	2.49	0.43
3:I:322:LEU:HD21	3:I:531:ALA:HB1	2.01	0.43
1:D:20:ILE:HD13	1:D:42:PHE:CE2	2.54	0.42
2:H:289:THR:HG21	3:I:499:GLN:NE2	2.34	0.42
2:K:427:TYR:CD2	2:K:431:GLU:HB2	2.54	0.42
1:D:52:TYR:HE2	1:D:149:GLN:CD	2.23	0.42
1:D:49:CYS:HB2	1:D:61:PHE:HB2	2.01	0.42
1:D:631:PHE:CD1	2:E:23:PRO:HB3	2.54	0.42
3:F:138:LYS:HD3	3:F:250:GLU:CG	2.48	0.42
3:F:444:PRO:O	3:F:448:VAL:HG23	2.18	0.42
1:G:226:LYS:HD2	2:H:466:ARG:NE	2.34	0.42
1:G:399:VAL:HB	1:G:427:GLN:HE22	1.84	0.42
2:H:632:PHE:CE1	3:I:102:ILE:HG23	2.53	0.42
1:J:407:ALA:HA	1:J:412:GLU:CG	2.49	0.42
1:J:410:GLU:CG	3:L:137:TRP:HB3	2.49	0.42
3:L:426:ALA:N	3:L:427:PRO:HD3	2.35	0.42
1:D:5:PHE:HB3	1:D:35:ILE:HD11	2.01	0.42
3:F:322:LEU:HD21	3:F:531:ALA:HB1	2.01	0.42
2:H:577:ILE:HA	2:H:580:PHE:HB3	2.01	0.42
3:I:426:ALA:N	3:I:427:PRO:HD3	2.34	0.42
3:I:575:LEU:HD11	3:I:582:ILE:CD1	2.36	0.42
3:L:444:PRO:O	3:L:448:VAL:HG23	2.19	0.42

*Continued on next page...*

*Continued from previous page...*

Atom-1	Atom-2	Interatomic distance (Å)	Clash overlap (Å)
1:D:52:TYR:OH	1:D:146:MET:HB2	2.19	0.42
1:D:174:PHE:HB2	1:D:179:GLU:HB2	2.00	0.42
1:D:17:ALA:HA	1:D:42:PHE:CE2	2.55	0.42
1:D:265:MET:HG2	1:D:434:GLU:HG2	2.01	0.42
1:D:454:GLY:H	1:D:492:LYS:HD2	1.85	0.42
1:D:52:TYR:CD1	1:D:146:MET:CE	3.01	0.42
3:F:426:ALA:N	3:F:427:PRO:HD3	2.34	0.42
3:F:551:HIS:ND1	3:F:551:HIS:O	2.53	0.42
3:F:474:PRO:CB	1:G:126:SER:O	2.67	0.42
1:J:558:LYS:HE3	3:L:49:LEU:HD11	2.01	0.42
1:D:233:ASN:HA	2:E:78:LEU:HG	2.01	0.42
2:B:179:LYS:C	1:G:203:PHE:HE1	2.22	0.42
2:H:686:GLN:OE1	3:I:39:THR:CB	2.65	0.42
1:J:426:LEU:HD21	1:J:621:LEU:HD22	2.01	0.42
2:B:265:CYS:HB3	2:B:274:PRO:HG3	2.02	0.42
3:F:473:ASN:HB3	3:F:474:PRO:HD2	2.01	0.42
1:G:25:VAL:HG21	1:G:35:ILE:HG22	2.02	0.42
1:G:265:MET:HG2	1:G:434:GLU:HG2	2.02	0.42
2:K:487:LEU:HD23	2:K:489:GLU:N	2.33	0.42
1:D:102:PHE:HB3	1:D:127:CYS:SG	2.59	0.42
1:D:20:ILE:HD13	1:D:42:PHE:CZ	2.55	0.42
1:D:418:LEU:HB3	2:E:543:SER:OG	2.19	0.42
2:H:79:VAL:HB	2:H:480:LEU:HD11	2.02	0.42
1:J:140:LYS:HE2	1:J:145:PRO:HD2	2.00	0.42
2:K:282:ALA:HB3	3:L:149:ARG:HD3	2.01	0.42
1:A:25:VAL:HG21	1:A:35:ILE:HG22	2.02	0.42
1:A:408:ASP:OD2	3:C:132:ARG:NH2	2.53	0.42
1:A:87:PRO:O	1:A:89:PRO:N	2.53	0.42
1:D:469:LYS:HB2	1:D:475:LEU:CD1	2.48	0.42
3:F:283:ASN:O	3:F:287:LYS:NZ	2.45	0.42
3:F:477:MET:HE1	1:G:126:SER:OG	2.20	0.42
2:B:179:LYS:HB3	1:G:203:PHE:HZ	1.84	0.42
1:G:222:GLU:O	1:G:226:LYS:HB2	2.20	0.42
3:L:172:TRP:CD1	3:L:186:ILE:HD11	2.55	0.42
3:L:283:ASN:O	3:L:287:LYS:NZ	2.46	0.42
1:A:632:CYS:HA	2:B:26:GLY:CA	2.50	0.42
2:E:704:PRO:HA	3:F:744:GLN:HG3	2.01	0.42
3:I:549:PHE:CZ	3:I:569:GLU:OE1	2.73	0.42
3:I:551:HIS:ND1	3:I:551:HIS:O	2.53	0.42
1:J:25:VAL:HG21	1:J:35:ILE:HG22	2.02	0.42
2:K:68:PHE:O	2:K:68:PHE:CD1	2.72	0.42

*Continued on next page...*

*Continued from previous page...*

Atom-1	Atom-2	Interatomic distance (Å)	Clash overlap (Å)
1:A:67:ARG:HD3	1:A:71:THR:HG21	2.02	0.42
3:F:626:GLN:O	3:F:632:TYR:HB3	2.20	0.42
3:F:600:VAL:HG13	3:F:642:PRO:HA	2.02	0.42
2:H:18:ILE:HD13	2:H:497:PHE:CD2	2.55	0.42
2:H:660:HIS:CE1	3:I:106:ASN:HD21	2.38	0.42
2:H:704:PRO:O	3:I:30:SER:HA	2.20	0.42
3:I:444:PRO:O	3:I:448:VAL:HG23	2.19	0.42
1:J:408:ASP:N	1:J:412:GLU:CB	2.82	0.42
2:K:746:ALA:HB1	3:L:15:CYS:SG	2.60	0.42
1:A:412:GLU:CG	2:B:601:ASN:ND2	2.82	0.41
3:F:475:GLY:HA2	1:G:86:GLU:HG2	2.01	0.41
1:G:140:LYS:HE2	1:G:145:PRO:HD2	2.01	0.41
1:G:59:ASP:OD2	3:I:769:LYS:NZ	2.52	0.41
1:A:88:LEU:CD2	1:A:102:PHE:CZ	3.01	0.41
1:A:345:ARG:NH1	3:F:136:MET:HB3	2.35	0.41
1:A:419:ASN:ND2	2:B:543:SER:OG	2.51	0.41
3:C:172:TRP:CD1	3:C:186:ILE:HD11	2.54	0.41
1:D:13:LEU:HD12	1:D:156:PHE:HZ	1.85	0.41
3:F:445:TYR:O	3:F:448:VAL:HB	2.20	0.41
1:J:245:LYS:HA	1:J:706:PHE:CB	2.51	0.41
3:L:551:HIS:ND1	3:L:551:HIS:O	2.53	0.41
1:D:245:LYS:HA	1:D:706:PHE:CB	2.50	0.41
1:D:25:VAL:HG21	1:D:35:ILE:HG22	2.03	0.41
1:D:426:LEU:HD21	1:D:621:LEU:HD22	2.02	0.41
1:G:201:LEU:HD13	1:G:203:PHE:CD2	2.55	0.41
1:G:518:LYS:HG3	1:G:519:HIS:CD2	2.55	0.41
3:I:626:GLN:O	3:I:632:TYR:HB3	2.20	0.41
2:K:487:LEU:CD2	2:K:489:GLU:HG3	2.50	0.41
1:A:245:LYS:HA	1:A:706:PHE:CB	2.50	0.41
2:B:577:ILE:HA	2:B:580:PHE:HB3	2.02	0.41
2:B:51:ARG:HH12	2:B:78:LEU:HA	1.86	0.41
3:C:445:TYR:O	3:C:448:VAL:HB	2.21	0.41
1:D:398:TRP:CE3	1:D:465:SER:HB2	2.55	0.41
1:D:518:LYS:HG3	1:D:519:HIS:CD2	2.56	0.41
2:B:686:GLN:NE2	3:C:39:THR:OG1	2.49	0.41
3:F:397:THR:HA	3:F:497:THR:O	2.20	0.41
1:G:88:LEU:HD12	1:G:123:LEU:HD22	2.02	0.41
1:J:222:GLU:O	1:J:226:LYS:HB2	2.21	0.41
3:L:322:LEU:HD21	3:L:531:ALA:HB1	2.01	0.41
2:B:182:LYS:NZ	1:G:205:THR:CG2	2.71	0.41
2:B:346:PHE:HA	2:B:349:LYS:HB3	2.03	0.41

*Continued on next page...*



*Continued from previous page...*

Atom-1	Atom-2	Interatomic distance (Å)	Clash overlap (Å)
3:C:426:ALA:N	3:C:427:PRO:HD3	2.35	0.41
3:F:474:PRO:CG	1:G:126:SER:O	2.69	0.41
1:J:469:LYS:CD	1:J:475:LEU:HD13	2.41	0.41
1:J:650:LEU:HB3	2:K:14:VAL:HG11	2.02	0.41
2:K:577:ILE:HA	2:K:580:PHE:HB3	2.01	0.41
2:E:265:CYS:HB3	2:E:274:PRO:HG3	2.01	0.41
3:F:422:TYR:CZ	3:F:449:MET:HG3	2.56	0.41
2:H:346:PHE:HA	2:H:349:LYS:HB3	2.03	0.41
3:I:600:VAL:HG13	3:I:642:PRO:HA	2.03	0.41
1:J:316:LEU:HD21	1:J:489:VAL:HG21	2.02	0.41
3:L:626:GLN:O	3:L:632:TYR:HB3	2.20	0.41
1:A:402:ALA:N	2:B:554:GLN:OE1	2.53	0.41
3:C:551:HIS:ND1	3:C:551:HIS:O	2.53	0.41
3:C:626:GLN:O	3:C:632:TYR:HB3	2.20	0.41
1:D:69:ARG:CZ	1:D:91:LEU:CG	2.91	0.41
2:E:346:PHE:HA	2:E:349:LYS:HB3	2.03	0.41
1:A:303:LYS:NZ	3:F:120:GLU:HB3	2.36	0.41
1:G:316:LEU:HD21	1:G:489:VAL:HG21	2.02	0.41
1:G:183:ILE:CD1	2:H:334:LEU:HD22	2.50	0.41
1:J:378:PHE:HA	1:J:379:PRO:HD3	1.97	0.41
1:J:680:ASN:N	1:J:680:ASN:ND2	2.65	0.41
2:K:542:PRO:HD3	3:L:247:TRP:CE2	2.56	0.41
2:K:51:ARG:HH12	2:K:78:LEU:HA	1.86	0.41
2:B:18:ILE:HD13	2:B:497:PHE:CD2	2.55	0.41
3:C:397:THR:HA	3:C:497:THR:O	2.21	0.41
2:E:279:GLU:HB2	3:F:224:PHE:CE2	2.56	0.41
1:D:197:GLU:O	2:E:65:ARG:CZ	2.69	0.41
1:D:410:GLU:HB2	3:F:249:GLN:OE1	2.21	0.41
3:F:358:ILE:N	3:F:423:PHE:HB3	2.34	0.41
1:D:565:SER:CB	3:F:52:ARG:HH22	2.34	0.41
3:I:681:SER:HB3	3:I:691:ILE:HD11	2.01	0.41
1:J:410:GLU:O	3:L:139:GLU:CB	2.68	0.41
2:B:294:ARG:HG3	3:C:395:TRP:CH2	2.55	0.41
3:C:600:VAL:HG13	3:C:642:PRO:HA	2.02	0.41
1:D:643:CYS:HA	1:D:646:GLN:HB3	2.03	0.41
1:G:412:GLU:CD	1:G:412:GLU:N	2.73	0.41
1:G:426:LEU:HD21	1:G:621:LEU:HD22	2.02	0.41
2:H:662:PHE:HB3	3:I:61:ILE:CG2	2.51	0.41
1:A:518:LYS:HG3	1:A:519:HIS:CD2	2.55	0.41
2:E:79:VAL:HB	2:E:480:LEU:HD11	2.02	0.41
1:G:245:LYS:HA	1:G:706:PHE:CB	2.51	0.41

*Continued on next page...*

Continued from previous page...

Atom-1	Atom-2	Interatomic distance (Å)	Clash overlap (Å)
1:J:450:ARG:NE	3:L:57:SER:OG	2.54	0.41
1:A:222:GLU:O	1:A:226:LYS:HB2	2.21	0.40
1:D:60:ARG:HG3	1:D:98:GLU:HB2	2.03	0.40
1:G:444:ALA:O	1:G:448:GLU:HG2	2.22	0.40
2:H:692:PHE:CD2	3:I:32:TYR:CD1	3.09	0.40
1:J:379:PRO:HB3	1:J:381:TRP:NE1	2.36	0.40
2:K:346:PHE:HA	2:K:349:LYS:HB3	2.03	0.40
1:A:67:ARG:NE	1:A:75:LEU:HD22	2.36	0.40
1:D:41:HIS:HE1	1:D:65:GLU:HG2	1.86	0.40
1:D:583:LEU:CD1	3:F:247:TRP:CZ2	3.04	0.40
1:J:398:TRP:CE3	1:J:465:SER:HB2	2.56	0.40
2:K:79:VAL:HB	2:K:480:LEU:HD11	2.02	0.40
1:A:316:LEU:HD22	1:A:339:PHE:CE2	2.57	0.40
1:A:155:SER:HB3	3:C:713:SER:OG	2.21	0.40
1:D:316:LEU:HD21	1:D:489:VAL:HG21	2.03	0.40
2:E:51:ARG:HH12	2:E:78:LEU:HA	1.85	0.40
3:F:692:ARG:HG3	3:F:694:PRO:HD2	2.02	0.40
1:G:398:TRP:CE3	1:G:465:SER:HB2	2.56	0.40
3:I:397:THR:HA	3:I:497:THR:O	2.21	0.40
2:K:491:PHE:HE1	2:K:493:PHE:HB2	1.87	0.40
1:A:338:GLU:HG2	3:F:254:ALA:CB	2.42	0.40
2:B:370:ILE:HD11	2:B:374:LYS:HB2	2.03	0.40
3:C:591:TYR:CD2	3:C:627:VAL:HG21	2.56	0.40
1:D:158:ALA:HB1	3:F:748:ARG:NE	2.37	0.40
1:J:407:ALA:HA	1:J:412:GLU:HB3	2.02	0.40
3:L:422:TYR:CZ	3:L:449:MET:HG3	2.56	0.40
1:A:444:ALA:O	1:A:448:GLU:HG2	2.22	0.40
1:D:222:GLU:O	1:D:226:LYS:HB2	2.20	0.40
1:D:444:ALA:O	1:D:448:GLU:HG2	2.22	0.40
2:E:370:ILE:HD11	2:E:374:LYS:HB2	2.03	0.40
2:E:404:LEU:HA	2:E:405:PRO:HD3	1.95	0.40
2:H:370:ILE:HD12	2:H:370:ILE:HA	1.98	0.40
2:H:370:ILE:HD11	2:H:374:LYS:HB2	2.02	0.40
1:J:677:CYS:SG	1:J:678:LEU:CD1	3.09	0.40
3:L:445:TYR:O	3:L:448:VAL:HB	2.21	0.40

All (18) symmetry-related close contacts are listed below. The label for Atom-2 includes the symmetry operator and encoded unit-cell translations to be applied.

Atom-1	Atom-2	Interatomic distance (Å)	Clash overlap (Å)
2:E:215:LYS:CE	3:I:628:THR:OG1[3_554]	0.85	1.35

Continued on next page...

Continued from previous page...

Atom-1	Atom-2	Interatomic distance (Å)	Clash overlap (Å)
2:E:215:LYS:NZ	3:I:628:THR:OG1[3_554]	0.92	1.28
2:E:215:LYS:CE	3:I:628:THR:CB[3_554]	1.49	0.71
2:B:457:TRP:N	1:J:84:ASP:OD2[1_565]	1.72	0.48
2:B:362:LYS:CE	1:D:81:LYS:NZ[1_655]	1.75	0.45
2:B:54:VAL:CG2	3:F:282:MET:CG[1_655]	1.75	0.45
2:B:54:VAL:CG2	3:F:282:MET:CB[1_655]	1.75	0.45
3:F:650:GLN:CG	1:J:143:GLU:CB[1_465]	1.79	0.41
2:B:362:LYS:NZ	1:D:81:LYS:NZ[1_655]	1.92	0.28
3:F:648:PRO:O	1:J:99:GLU:OE2[1_465]	1.92	0.28
2:B:384:GLU:OE1	1:D:75:LEU:CG[1_655]	1.96	0.24
1:A:223:LEU:C	3:F:559:ASP:OD2[1_655]	2.03	0.17
2:E:215:LYS:CD	3:I:628:THR:OG1[3_554]	2.05	0.15
3:F:647:ALA:CB	1:J:99:GLU:O[1_465]	2.11	0.09
1:D:363:GLU:CD	1:G:592:ASN:O[3_654]	2.12	0.08
1:D:363:GLU:OE1	1:G:592:ASN:N[3_654]	2.16	0.04
3:F:645:TYR:O	1:J:100:LYS:NZ[1_465]	2.17	0.03
3:F:650:GLN:CG	1:J:143:GLU:CG[1_465]	2.17	0.03

## 5.3 Torsion angles [i](#)

### 5.3.1 Protein backbone [i](#)

In the following table, the Percentiles column shows the percent Ramachandran outliers of the chain as a percentile score with respect to all X-ray entries followed by that with respect to entries of similar resolution.

The Analysed column shows the number of residues for which the backbone conformation was analysed, and the total number of residues.

Mol	Chain	Analysed	Favoured	Allowed	Outliers	Percentiles
1	A	685/709 (97%)	631 (92%)	51 (7%)	3 (0%)	34 72
1	D	685/709 (97%)	634 (93%)	49 (7%)	2 (0%)	41 76
1	G	685/709 (97%)	635 (93%)	48 (7%)	2 (0%)	41 76
1	J	685/709 (97%)	633 (92%)	50 (7%)	2 (0%)	41 76
2	B	703/754 (93%)	670 (95%)	30 (4%)	3 (0%)	34 72
2	E	703/754 (93%)	669 (95%)	31 (4%)	3 (0%)	34 72
2	H	703/754 (93%)	670 (95%)	30 (4%)	3 (0%)	34 72
2	K	703/754 (93%)	669 (95%)	31 (4%)	3 (0%)	34 72

Continued on next page...

*Continued from previous page...*

Mol	Chain	Analysed	Favoured	Allowed	Outliers	Percentiles	
3	C	746/782 (95%)	679 (91%)	64 (9%)	3 (0%)	34	72
3	F	756/782 (97%)	683 (90%)	69 (9%)	4 (0%)	29	68
3	I	756/782 (97%)	685 (91%)	68 (9%)	3 (0%)	34	72
3	L	756/782 (97%)	686 (91%)	67 (9%)	3 (0%)	34	72
All	All	8566/8980 (95%)	7944 (93%)	588 (7%)	34 (0%)	34	72

All (34) Ramachandran outliers are listed below:

Mol	Chain	Res	Type
2	B	503	VAL
2	E	503	VAL
3	F	758	ALA
2	H	503	VAL
2	K	503	VAL
3	C	533	ILE
1	D	141	ASN
3	F	533	ILE
3	I	533	ILE
3	L	533	ILE
1	A	141	ASN
1	G	141	ASN
1	J	141	ASN
1	A	87	PRO
2	B	405	PRO
2	E	405	PRO
2	H	405	PRO
2	K	405	PRO
3	C	550	GLN
2	E	23	PRO
3	F	550	GLN
3	I	550	GLN
3	L	550	GLN
2	B	23	PRO
2	H	23	PRO
2	K	23	PRO
3	C	745	GLY
3	F	745	GLY
3	I	745	GLY
3	L	745	GLY
1	J	679	ILE
1	A	679	ILE

*Continued on next page...*

*Continued from previous page...*

Mol	Chain	Res	Type
1	D	679	ILE
1	G	679	ILE

### 5.3.2 Protein sidechains [i](#)

In the following table, the Percentiles column shows the percent sidechain outliers of the chain as a percentile score with respect to all X-ray entries followed by that with respect to entries of similar resolution.

The Analysed column shows the number of residues for which the sidechain conformation was analysed, and the total number of residues.

Mol	Chain	Analysed	Rotameric	Outliers	Percentiles	
1	A	618/631 (98%)	610 (99%)	8 (1%)	69	82
1	D	618/631 (98%)	610 (99%)	8 (1%)	69	82
1	G	618/631 (98%)	608 (98%)	10 (2%)	62	79
1	J	618/631 (98%)	608 (98%)	10 (2%)	62	79
2	B	629/669 (94%)	617 (98%)	12 (2%)	57	75
2	E	629/669 (94%)	617 (98%)	12 (2%)	57	75
2	H	629/669 (94%)	617 (98%)	12 (2%)	57	75
2	K	629/669 (94%)	617 (98%)	12 (2%)	57	75
3	C	663/686 (97%)	649 (98%)	14 (2%)	53	72
3	F	669/686 (98%)	656 (98%)	13 (2%)	57	75
3	I	669/686 (98%)	656 (98%)	13 (2%)	57	75
3	L	669/686 (98%)	656 (98%)	13 (2%)	57	75
All	All	7658/7944 (96%)	7521 (98%)	137 (2%)	59	77

All (137) residues with a non-rotameric sidechain are listed below:

Mol	Chain	Res	Type
1	A	38	ILE
1	A	48	PHE
1	A	163	PHE
1	A	170	PHE
1	A	276	ASP
1	A	490	LYS
1	A	506	THR
1	A	554	THR

*Continued on next page...*

*Continued from previous page...*

<b>Mol</b>	<b>Chain</b>	<b>Res</b>	<b>Type</b>
2	B	59	LYS
2	B	147	GLN
2	B	166	LEU
2	B	273	LEU
2	B	279	GLU
2	B	302	VAL
2	B	491	PHE
2	B	502	PHE
2	B	540	LEU
2	B	618	ASP
2	B	657	VAL
2	B	665	ARG
3	C	4	LEU
3	C	39	THR
3	C	135	ILE
3	C	139	GLU
3	C	152	VAL
3	C	160	ARG
3	C	175	PHE
3	C	504	ASP
3	C	518	ASP
3	C	594	LEU
3	C	611	ARG
3	C	695	LEU
3	C	720	ARG
3	C	738	VAL
1	D	38	ILE
1	D	163	PHE
1	D	170	PHE
1	D	276	ASP
1	D	482	ASP
1	D	490	LYS
1	D	506	THR
1	D	554	THR
2	E	59	LYS
2	E	147	GLN
2	E	166	LEU
2	E	273	LEU
2	E	279	GLU
2	E	302	VAL
2	E	491	PHE
2	E	502	PHE

*Continued on next page...*

*Continued from previous page...*

<b>Mol</b>	<b>Chain</b>	<b>Res</b>	<b>Type</b>
2	E	540	LEU
2	E	618	ASP
2	E	657	VAL
2	E	665	ARG
3	F	4	LEU
3	F	39	THR
3	F	135	ILE
3	F	152	VAL
3	F	160	ARG
3	F	175	PHE
3	F	504	ASP
3	F	518	ASP
3	F	594	LEU
3	F	611	ARG
3	F	695	LEU
3	F	720	ARG
3	F	738	VAL
1	G	38	ILE
1	G	48	PHE
1	G	163	PHE
1	G	170	PHE
1	G	205	THR
1	G	276	ASP
1	G	482	ASP
1	G	490	LYS
1	G	506	THR
1	G	554	THR
2	H	59	LYS
2	H	147	GLN
2	H	166	LEU
2	H	273	LEU
2	H	279	GLU
2	H	302	VAL
2	H	491	PHE
2	H	502	PHE
2	H	540	LEU
2	H	618	ASP
2	H	657	VAL
2	H	665	ARG
3	I	4	LEU
3	I	135	ILE
3	I	139	GLU

*Continued on next page...*

*Continued from previous page...*

<b>Mol</b>	<b>Chain</b>	<b>Res</b>	<b>Type</b>
3	I	152	VAL
3	I	160	ARG
3	I	175	PHE
3	I	504	ASP
3	I	518	ASP
3	I	594	LEU
3	I	611	ARG
3	I	695	LEU
3	I	720	ARG
3	I	738	VAL
1	J	38	ILE
1	J	48	PHE
1	J	163	PHE
1	J	170	PHE
1	J	276	ASP
1	J	482	ASP
1	J	490	LYS
1	J	506	THR
1	J	554	THR
1	J	680	ASN
2	K	59	LYS
2	K	147	GLN
2	K	166	LEU
2	K	273	LEU
2	K	279	GLU
2	K	302	VAL
2	K	491	PHE
2	K	502	PHE
2	K	540	LEU
2	K	618	ASP
2	K	657	VAL
2	K	665	ARG
3	L	4	LEU
3	L	39	THR
3	L	135	ILE
3	L	152	VAL
3	L	160	ARG
3	L	175	PHE
3	L	504	ASP
3	L	518	ASP
3	L	594	LEU
3	L	611	ARG

*Continued on next page...*



*Continued from previous page...*

Mol	Chain	Res	Type
3	L	695	LEU
3	L	720	ARG
3	L	738	VAL

Some sidechains can be flipped to improve hydrogen bonding and reduce clashes. All (41) such sidechains are listed below:

Mol	Chain	Res	Type
1	A	31	HIS
1	A	519	HIS
1	A	644	ASN
2	B	303	ASN
2	B	316	GLN
2	B	477	ASN
2	B	627	ASN
3	C	550	GLN
1	D	41	HIS
1	D	204	GLN
1	D	519	HIS
1	D	644	ASN
2	E	303	ASN
2	E	316	GLN
2	E	477	ASN
2	E	627	ASN
2	E	660	HIS
2	E	686	GLN
3	F	550	GLN
1	G	31	HIS
1	G	208	GLN
1	G	312	HIS
1	G	519	HIS
1	G	628	GLN
2	H	303	ASN
2	H	316	GLN
2	H	477	ASN
2	H	627	ASN
2	H	660	HIS
3	I	330	GLN
3	I	550	GLN
1	J	31	HIS
1	J	409	ASN
1	J	519	HIS
1	J	680	ASN

*Continued on next page...*

*Continued from previous page...*

Mol	Chain	Res	Type
2	K	303	ASN
2	K	316	GLN
2	K	477	ASN
2	K	627	ASN
3	L	545	GLN
3	L	550	GLN

### 5.3.3 RNA [i](#)

There are no RNA molecules in this entry.

### 5.4 Non-standard residues in protein, DNA, RNA chains [i](#)

There are no non-standard protein/DNA/RNA residues in this entry.

### 5.5 Carbohydrates [i](#)

There are no carbohydrates in this entry.

### 5.6 Ligand geometry [i](#)

There are no ligands in this entry.

### 5.7 Other polymers [i](#)

There are no such residues in this entry.

### 5.8 Polymer linkage issues [i](#)

There are no chain breaks in this entry.

## 6 Fit of model and data i

### 6.1 Protein, DNA and RNA chains i

In the following table, the column labelled ‘#RSRZ> 2’ contains the number (and percentage) of RSRZ outliers, followed by percent RSRZ outliers for the chain as percentile scores relative to all X-ray entries and entries of similar resolution. The OWAB column contains the minimum, median, 95<sup>th</sup> percentile and maximum values of the occupancy-weighted average B-factor per residue. The column labelled ‘Q< 0.9’ lists the number of (and percentage) of residues with an average occupancy less than 0.9.

Mol	Chain	Analysed	<RSRZ>	#RSRZ>2	OWAB(Å <sup>2</sup> )	Q<0.9
1	A	693/709 (97%)	0.36	47 (6%) 17 14	66, 164, 326, 490	0
1	D	693/709 (97%)	0.13	20 (2%) 51 41	72, 156, 252, 382	0
1	G	693/709 (97%)	0.43	69 (9%) 7 7	90, 180, 290, 407	0
1	J	693/709 (97%)	0.18	21 (3%) 50 39	105, 181, 273, 414	0
2	B	711/754 (94%)	0.20	41 (5%) 23 19	70, 147, 290, 437	0
2	E	711/754 (94%)	0.21	34 (4%) 30 26	71, 143, 270, 490	0
2	H	711/754 (94%)	0.33	44 (6%) 20 17	82, 170, 287, 498	0
2	K	711/754 (94%)	0.49	63 (8%) 9 8	83, 173, 284, 424	0
3	C	754/782 (96%)	0.99	168 (22%) 0 1	99, 240, 349, 416	0
3	F	762/782 (97%)	0.30	44 (5%) 23 19	87, 174, 295, 481	0
3	I	762/782 (97%)	0.66	89 (11%) 4 5	95, 224, 337, 500	0
3	L	762/782 (97%)	0.84	136 (17%) 1 2	108, 226, 332, 476	0
All	All	8656/8980 (96%)	0.43	776 (8%) 9 8	66, 181, 315, 500	0

All (776) RSRZ outliers are listed below:

Mol	Chain	Res	Type	RSRZ
3	I	95	VAL	15.1
3	L	656	ARG	10.7
3	C	665	VAL	10.4
3	L	655	GLY	9.5
3	I	96	LEU	9.4
3	I	422	TYR	7.3
3	C	446	GLN	7.3
3	C	687	HIS	7.1
3	F	491	LYS	7.0
3	C	425	ASP	6.9
1	A	63	LEU	6.7

*Continued on next page...*

*Continued from previous page...*

<b>Mol</b>	<b>Chain</b>	<b>Res</b>	<b>Type</b>	<b>RSRZ</b>
3	C	695	LEU	6.6
3	L	107	PHE	6.5
3	C	640	VAL	6.5
3	C	63	ALA	6.4
3	C	643	PHE	6.4
2	H	738	GLU	6.1
3	C	83	TRP	6.1
3	L	469	ILE	5.9
3	L	488	ARG	5.9
2	E	67	LYS	5.8
3	C	72	GLN	5.8
3	L	424	LYS	5.8
2	H	184	LYS	5.8
3	I	433	ALA	5.7
1	G	707	LYS	5.6
3	C	686	CYS	5.5
3	I	429	THR	5.5
3	C	605	PRO	5.4
1	J	708	THR	5.4
3	I	446	GLN	5.4
1	J	499	ASP	5.4
3	C	603	MET	5.4
3	C	696	VAL	5.4
3	L	73	ILE	5.3
3	L	83	TRP	5.3
3	L	431	THR	5.2
3	C	110	PRO	5.2
3	C	447	TYR	5.2
3	C	639	LYS	5.2
3	C	422	TYR	5.2
2	H	632	PHE	5.2
3	C	685	TYR	5.1
1	G	499	ASP	5.1
3	L	696	VAL	5.1
3	L	703	ASP	5.1
3	I	106	ASN	5.0
3	C	71	ALA	4.9
3	C	286	SER	4.9
3	L	443	ILE	4.9
3	C	606	LEU	4.9
3	C	418	ARG	4.8
3	F	737	LYS	4.8

*Continued on next page...*

*Continued from previous page...*

<b>Mol</b>	<b>Chain</b>	<b>Res</b>	<b>Type</b>	<b>RSRZ</b>
3	L	654	GLU	4.8
3	I	467	ARG	4.8
2	K	405	PRO	4.8
3	C	358	ILE	4.8
1	A	102	PHE	4.8
1	A	119	LYS	4.7
1	A	130	PHE	4.7
3	I	418	ARG	4.7
3	L	532	THR	4.6
3	I	434	ASP	4.6
3	C	726	ARG	4.6
2	E	629	LYS	4.6
3	C	642	PRO	4.6
1	A	95	PHE	4.6
1	A	92	CYS	4.5
1	A	69	ARG	4.5
1	G	60	ARG	4.5
3	I	415	ILE	4.5
3	L	648	PRO	4.5
3	I	102	ILE	4.5
3	L	615	TYR	4.5
1	A	123	LEU	4.5
3	I	447	TYR	4.5
3	L	11	TYR	4.4
3	C	67	MET	4.4
3	L	358	ILE	4.4
3	I	94	HIS	4.4
3	C	645	TYR	4.4
3	I	365	GLN	4.4
3	C	96	LEU	4.4
3	L	468	GLY	4.4
3	L	72	GLN	4.4
3	C	391	ARG	4.4
3	I	72	GLN	4.4
3	C	106	ASN	4.4
3	I	367	GLU	4.4
3	L	442	GLU	4.4
2	B	67	LYS	4.4
3	I	279	ALA	4.4
1	D	499	ASP	4.3
2	H	682	GLU	4.3
2	K	440	THR	4.3

*Continued on next page...*

*Continued from previous page...*

<b>Mol</b>	<b>Chain</b>	<b>Res</b>	<b>Type</b>	<b>RSRZ</b>
2	B	233	GLY	4.3
2	K	67	LYS	4.3
3	I	443	ILE	4.3
3	I	110	PRO	4.3
2	H	739	ILE	4.2
3	F	85	ASP	4.2
3	C	587	ALA	4.2
3	L	611	ARG	4.2
3	L	111	CYS	4.2
3	L	643	PHE	4.2
3	F	110	PRO	4.2
1	G	102	PHE	4.2
3	I	703	ASP	4.2
3	L	531	ALA	4.2
3	L	429	THR	4.2
3	L	425	ASP	4.1
3	L	491	LYS	4.1
2	H	742	ILE	4.1
3	L	444	PRO	4.1
3	C	586	ILE	4.1
3	C	178	GLU	4.0
2	K	406	GLY	4.0
1	G	98	GLU	4.0
3	L	521	GLU	4.0
3	F	95	VAL	4.0
1	G	67	ARG	4.0
3	C	365	GLN	4.0
3	I	22	GLN	4.0
1	A	62	VAL	4.0
3	I	148	GLN	4.0
3	L	657	LEU	3.9
1	G	693	GLU	3.9
3	C	491	LYS	3.9
3	C	520	LEU	3.9
3	I	450	MET	3.9
1	J	664	GLY	3.9
3	L	464	LEU	3.9
2	K	624	ARG	3.9
1	A	28	TYR	3.9
3	C	607	ILE	3.9
3	L	618	VAL	3.9
3	L	110	PRO	3.9

*Continued on next page...*

*Continued from previous page...*

<b>Mol</b>	<b>Chain</b>	<b>Res</b>	<b>Type</b>	<b>RSRZ</b>
3	C	421	ASP	3.9
3	L	418	ARG	3.9
1	A	64	ILE	3.9
3	F	648	PRO	3.9
3	C	285	LYS	3.8
3	C	617	ARG	3.8
3	I	469	ILE	3.8
2	H	183	PHE	3.8
3	I	425	ASP	3.8
3	C	618	VAL	3.8
1	J	494	HIS	3.8
2	B	581	ILE	3.8
1	A	103	VAL	3.8
2	K	441	GLY	3.8
3	C	15	CYS	3.8
3	C	95	VAL	3.8
3	L	487	LYS	3.8
2	K	83	GLY	3.8
1	G	76	GLN	3.8
1	G	94	ILE	3.8
3	L	479	SER	3.8
2	H	187	LYS	3.8
1	G	356	THR	3.7
3	C	564	ILE	3.7
3	L	666	GLU	3.7
2	B	739	ILE	3.7
3	I	77	HIS	3.7
3	F	357	TYR	3.7
3	I	465	TYR	3.7
1	A	104	GLU	3.7
3	C	328	GLY	3.7
3	L	483	ILE	3.7
2	K	318	GLU	3.7
1	G	83	TYR	3.7
2	B	736	TYR	3.7
3	C	560	GLU	3.7
3	L	642	PRO	3.7
2	B	578	ASN	3.7
1	G	125	ASN	3.7
3	C	594	LEU	3.7
3	L	400	GLY	3.7
3	C	109	GLY	3.7

*Continued on next page...*

*Continued from previous page...*

<b>Mol</b>	<b>Chain</b>	<b>Res</b>	<b>Type</b>	<b>RSRZ</b>
3	F	425	ASP	3.7
3	C	415	ILE	3.6
3	C	467	ARG	3.6
3	C	448	VAL	3.6
3	L	641	LEU	3.6
2	H	405	PRO	3.6
3	F	715	CYS	3.6
3	C	1	MET	3.6
1	G	61	PHE	3.6
3	I	444	PRO	3.6
3	C	493	LEU	3.6
3	C	64	ASN	3.6
2	E	68	PHE	3.6
3	L	493	LEU	3.6
2	K	300	PHE	3.6
3	C	623	VAL	3.6
3	C	626	GLN	3.6
3	I	449	MET	3.6
1	G	147	GLU	3.6
3	I	431	THR	3.6
2	B	742	ILE	3.5
2	K	620	GLN	3.5
2	B	624	ARG	3.5
3	C	614	VAL	3.5
2	H	583	THR	3.5
1	A	105	ILE	3.5
3	C	641	LEU	3.5
3	C	647	ALA	3.5
3	L	355	THR	3.5
3	I	445	TYR	3.5
3	C	108	CYS	3.5
3	F	560	GLU	3.4
3	L	533	ILE	3.4
1	A	125	ASN	3.4
3	I	419	ASP	3.4
1	D	130	PHE	3.4
3	I	63	ALA	3.4
2	K	82	THR	3.4
3	L	112	VAL	3.4
3	C	604	ALA	3.4
3	I	556	VAL	3.4
3	C	737	LYS	3.4

*Continued on next page...*



*Continued from previous page...*

<b>Mol</b>	<b>Chain</b>	<b>Res</b>	<b>Type</b>	<b>RSRZ</b>
3	L	105	TRP	3.4
1	G	535	LYS	3.4
2	B	678	MET	3.4
1	J	707	LYS	3.4
1	G	708	THR	3.3
2	E	674	ASP	3.3
3	C	666	GLU	3.3
3	F	655	GLY	3.3
1	A	132	PHE	3.3
3	L	415	ILE	3.3
1	A	143	GLU	3.3
2	B	677	ALA	3.3
3	F	101	CYS	3.3
3	I	14	LEU	3.3
3	L	494	ARG	3.3
1	A	94	ILE	3.3
3	C	444	PRO	3.3
1	A	66	GLY	3.3
2	K	594	ASP	3.3
3	C	423	PHE	3.3
3	C	619	ALA	3.3
1	G	97	ARG	3.3
2	B	717	LYS	3.3
2	H	721	ARG	3.3
3	I	93	ASP	3.3
2	B	190	VAL	3.3
2	K	582	LYS	3.3
3	L	432	MET	3.3
3	C	577	THR	3.3
1	G	96	ASP	3.3
3	F	72	GLN	3.3
1	G	333	GLU	3.3
3	L	71	ALA	3.3
2	E	83	GLY	3.2
3	L	75	LYS	3.2
2	H	631	PRO	3.2
2	K	50	SER	3.2
1	J	198	SER	3.2
3	C	482	GLY	3.2
3	F	83	TRP	3.2
1	G	705	PHE	3.2
1	G	355	LEU	3.2

*Continued on next page...*

*Continued from previous page...*

<b>Mol</b>	<b>Chain</b>	<b>Res</b>	<b>Type</b>	<b>RSRZ</b>
2	K	621	TYR	3.2
3	C	483	ILE	3.2
3	L	640	VAL	3.2
3	C	658	PHE	3.2
3	I	488	ARG	3.2
3	I	483	ILE	3.2
3	L	610	ASN	3.2
2	H	406	GLY	3.2
2	K	68	PHE	3.2
2	E	621	TYR	3.2
1	G	592	ASN	3.2
2	B	68	PHE	3.2
3	I	430	ILE	3.2
3	L	729	LEU	3.2
1	G	342	GLY	3.2
2	K	685	TYR	3.2
3	L	108	CYS	3.2
3	C	667	PRO	3.2
3	C	480	SER	3.1
3	C	481	MET	3.1
3	L	109	GLY	3.1
3	C	646	PHE	3.1
3	F	77	HIS	3.1
1	J	98	GLU	3.1
1	A	107	ILE	3.1
1	A	127	CYS	3.1
1	D	483	CYS	3.1
2	K	227	ASN	3.1
3	C	596	ASN	3.1
3	C	644	THR	3.1
3	L	383	THR	3.1
3	C	38	TRP	3.1
2	B	630	ASN	3.1
1	J	248	GLN	3.1
3	I	366	PHE	3.1
1	D	380	ARG	3.1
3	F	15	CYS	3.1
3	L	644	THR	3.1
3	L	101	CYS	3.1
3	L	104	TYR	3.1
1	G	47	MET	3.1
1	D	379	PRO	3.1

*Continued on next page...*

*Continued from previous page...*

<b>Mol</b>	<b>Chain</b>	<b>Res</b>	<b>Type</b>	<b>RSRZ</b>
3	F	492	SER	3.1
2	K	439	TRP	3.1
2	H	186	VAL	3.1
3	C	672	ASN	3.1
2	B	230	ALA	3.1
3	C	388	ARG	3.1
3	L	619	ALA	3.1
3	F	73	ILE	3.1
3	C	633	SER	3.1
3	C	556	VAL	3.1
1	A	34	LYS	3.0
3	C	419	ASP	3.0
2	H	504	SER	3.0
3	F	604	ALA	3.0
2	E	620	GLN	3.0
1	A	467	GLU	3.0
3	L	95	VAL	3.0
1	A	126	SER	3.0
1	A	128	LYS	3.0
2	B	231	LYS	3.0
3	L	612	LYS	3.0
3	I	83	TRP	3.0
3	C	91	LYS	3.0
3	C	568	TYR	3.0
3	I	92	ARG	3.0
3	I	529	ILE	3.0
3	L	398	ILE	3.0
1	G	241	TYR	3.0
2	B	582	LYS	3.0
1	G	101	GLN	3.0
3	C	688	GLY	3.0
2	H	685	TYR	3.0
1	J	366	LYS	3.0
3	F	63	ALA	3.0
3	F	71	ALA	3.0
1	J	665	PHE	3.0
3	I	414	MET	3.0
2	E	720	GLU	3.0
2	K	348	ASN	3.0
3	I	454	GLN	3.0
3	C	85	ASP	2.9
3	I	464	LEU	2.9

*Continued on next page...*

*Continued from previous page...*

<b>Mol</b>	<b>Chain</b>	<b>Res</b>	<b>Type</b>	<b>RSRZ</b>
2	B	629	LYS	2.9
1	A	35	ILE	2.9
3	L	475	GLY	2.9
3	C	97	ALA	2.9
3	C	660	SER	2.9
1	A	145	PRO	2.9
3	C	68	LEU	2.9
2	H	185	LYS	2.9
3	C	393	LEU	2.9
2	E	406	GLY	2.9
2	K	682	GLU	2.9
3	L	106	ASN	2.9
3	L	490	ILE	2.9
3	C	683	LYS	2.9
3	C	81	ALA	2.9
1	G	66	GLY	2.9
3	L	77	HIS	2.9
3	L	423	PHE	2.9
3	C	8	ALA	2.9
2	E	405	PRO	2.9
3	C	420	GLY	2.9
3	L	520	LEU	2.9
3	C	416	PHE	2.9
3	I	15	CYS	2.9
2	K	571	GLY	2.9
3	L	87	GLU	2.8
2	K	64	PRO	2.8
3	I	603	MET	2.8
3	L	463	LEU	2.8
1	A	67	ARG	2.8
3	L	653	PHE	2.8
1	D	500	GLY	2.8
3	L	386	PHE	2.8
3	C	367	GLU	2.8
3	I	105	TRP	2.8
1	A	463	ALA	2.8
3	C	615	TYR	2.8
1	G	92	CYS	2.8
1	G	364	GLY	2.8
3	C	336	SER	2.8
3	L	446	GLN	2.8
3	C	496	VAL	2.8

*Continued on next page...*

*Continued from previous page...*

<b>Mol</b>	<b>Chain</b>	<b>Res</b>	<b>Type</b>	<b>RSRZ</b>
3	C	12	LYS	2.8
3	I	643	PHE	2.8
3	L	695	LEU	2.8
2	H	722	ALA	2.8
1	J	518	LYS	2.8
2	K	237	LYS	2.8
2	K	450	LEU	2.8
1	J	463	ALA	2.8
1	G	238	ILE	2.8
2	K	407	GLY	2.8
2	K	583	THR	2.8
2	H	233	GLY	2.8
3	F	111	CYS	2.8
3	I	81	ALA	2.8
3	L	433	ALA	2.8
1	A	106	GLY	2.8
1	G	661	SER	2.8
1	A	47	MET	2.8
3	I	687	HIS	2.8
3	C	613	GLY	2.8
1	A	122	LYS	2.8
2	B	621	TYR	2.8
3	I	71	ALA	2.8
3	F	107	PHE	2.8
3	C	73	ILE	2.8
3	L	96	LEU	2.8
2	B	232	ASP	2.7
2	E	180	GLU	2.7
3	L	723	MET	2.8
3	C	612	LYS	2.7
3	C	84	GLU	2.7
3	C	7	ILE	2.7
3	C	463	LEU	2.7
3	L	84	GLU	2.7
1	A	45	CYS	2.7
2	H	217	ASP	2.7
3	I	336	SER	2.7
3	L	97	ALA	2.7
1	G	665	PHE	2.7
2	H	678	MET	2.7
3	I	278	ASN	2.7
2	B	631	PRO	2.7

*Continued on next page...*

*Continued from previous page...*

<b>Mol</b>	<b>Chain</b>	<b>Res</b>	<b>Type</b>	<b>RSRZ</b>
2	H	182	LYS	2.7
3	F	112	VAL	2.7
3	F	422	TYR	2.7
3	L	652	MET	2.7
3	L	438	LYS	2.7
2	K	7	LEU	2.7
3	L	367	GLU	2.7
3	L	649	LYS	2.7
3	F	282	MET	2.7
1	G	64	ILE	2.7
2	H	490	LEU	2.7
3	C	725	THR	2.7
2	B	594	ASP	2.7
1	G	378	PHE	2.7
2	K	468	ASN	2.7
3	C	585	LEU	2.7
3	C	105	TRP	2.7
2	B	740	LYS	2.7
2	E	594	ASP	2.7
3	L	530	VAL	2.7
3	I	682	SER	2.7
3	C	661	ASN	2.6
2	E	472	LYS	2.6
3	I	683	LYS	2.6
3	L	465	TYR	2.6
2	K	6	TYR	2.6
3	C	664	PHE	2.6
3	F	471	GLU	2.6
3	I	386	PHE	2.6
3	F	490	ILE	2.6
3	L	480	SER	2.6
1	J	101	GLN	2.6
1	G	105	ILE	2.6
3	C	111	CYS	2.6
1	G	664	GLY	2.6
2	K	578	ASN	2.6
1	D	257	ALA	2.6
3	L	498	ILE	2.6
2	E	624	ARG	2.6
3	F	652	MET	2.6
2	K	655	ALA	2.6
3	C	75	LYS	2.6

*Continued on next page...*

*Continued from previous page...*

<b>Mol</b>	<b>Chain</b>	<b>Res</b>	<b>Type</b>	<b>RSRZ</b>
3	I	766	ASN	2.6
1	A	466	LYS	2.6
2	K	631	PRO	2.6
2	B	620	GLN	2.6
3	C	484	ASP	2.6
1	A	91	LEU	2.6
1	D	364	GLY	2.6
3	L	419	ASP	2.6
2	E	237	LYS	2.6
3	C	748	ARG	2.6
2	K	490	LEU	2.6
3	C	394	GLU	2.6
2	K	678	MET	2.6
2	K	438	PHE	2.6
3	C	744	GLN	2.6
3	I	38	TRP	2.6
2	H	482	LYS	2.6
2	E	570	LYS	2.5
2	K	49	TYR	2.5
3	L	658	PHE	2.5
2	K	403	PHE	2.5
3	C	727	GLN	2.5
3	I	557	LEU	2.5
3	L	478	GLY	2.5
2	B	625	VAL	2.5
2	K	301	ALA	2.5
3	I	411	ALA	2.5
1	G	88	LEU	2.5
3	C	632	TYR	2.5
1	J	380	ARG	2.5
3	L	496	VAL	2.5
2	H	718	LEU	2.5
2	E	188	THR	2.5
2	K	477	ASN	2.5
3	L	422	TYR	2.5
1	A	42	PHE	2.5
3	I	91	LYS	2.5
1	G	99	GLU	2.5
3	C	16	GLN	2.5
3	C	70	GLU	2.5
2	H	435	LYS	2.5
3	C	638	ILE	2.5

*Continued on next page...*

*Continued from previous page...*

<b>Mol</b>	<b>Chain</b>	<b>Res</b>	<b>Type</b>	<b>RSRZ</b>
2	E	82	THR	2.5
1	D	267	GLU	2.5
2	K	184	LYS	2.5
3	L	467	ARG	2.5
3	L	726	ARG	2.5
3	I	424	LYS	2.5
3	L	495	ALA	2.5
1	G	104	GLU	2.5
3	L	744	GLN	2.5
3	L	472	THR	2.5
2	H	725	LYS	2.5
3	L	103	ASN	2.5
2	K	580	PHE	2.5
3	F	75	LYS	2.4
3	I	481	MET	2.4
3	C	342	LEU	2.4
2	B	743	ILE	2.4
3	F	481	MET	2.4
3	I	397	THR	2.4
3	C	563	ALA	2.4
2	E	314	CYS	2.4
3	C	94	HIS	2.4
1	J	195	ARG	2.4
2	B	716	GLU	2.4
1	G	248	GLN	2.4
1	G	244	ASN	2.4
3	C	673	VAL	2.4
2	B	674	ASP	2.4
2	E	66	ARG	2.4
1	A	70	GLY	2.4
3	L	4	LEU	2.4
3	L	614	VAL	2.4
2	B	681	GLU	2.4
2	K	65	ARG	2.4
2	K	66	ARG	2.4
3	C	674	PHE	2.4
3	L	139	GLU	2.4
1	G	689	GLN	2.4
3	L	516	LEU	2.4
3	C	417	CYS	2.4
1	A	533	ARG	2.4
3	F	74	PRO	2.4

*Continued on next page...*



*Continued from previous page...*

<b>Mol</b>	<b>Chain</b>	<b>Res</b>	<b>Type</b>	<b>RSRZ</b>
2	H	155	GLU	2.4
3	F	108	CYS	2.4
1	J	102	PHE	2.4
2	E	632	PHE	2.4
3	L	384	ALA	2.4
2	B	587	LYS	2.4
3	I	75	LYS	2.4
1	G	381	TRP	2.4
1	G	382	PHE	2.4
2	K	463	THR	2.4
3	C	431	THR	2.4
2	E	581	ILE	2.4
2	H	209	MET	2.4
3	L	412	MET	2.4
3	L	636	GLU	2.4
2	E	50	SER	2.4
2	B	632	PHE	2.4
3	I	337	PHE	2.4
2	K	570	LYS	2.4
2	H	181	ILE	2.4
3	L	484	ASP	2.4
1	G	48	PHE	2.4
3	C	637	LEU	2.4
3	I	673	VAL	2.4
3	C	366	PHE	2.3
2	H	398	GLN	2.3
2	K	443	GLN	2.3
3	C	524	ASP	2.3
3	I	64	ASN	2.3
1	D	363	GLU	2.3
1	D	382	PHE	2.3
1	G	352	GLU	2.3
2	K	183	PHE	2.3
3	I	396	ILE	2.3
2	B	83	GLY	2.3
1	A	90	PHE	2.3
1	G	79	LEU	2.3
1	A	480	GLU	2.3
2	H	436	GLY	2.3
3	C	337	PHE	2.3
3	I	412	MET	2.3
3	I	513	HIS	2.3

*Continued on next page...*

*Continued from previous page...*

<b>Mol</b>	<b>Chain</b>	<b>Res</b>	<b>Type</b>	<b>RSRZ</b>
1	A	366	LYS	2.3
3	I	87	GLU	2.3
3	C	340	MET	2.3
3	F	716	GLU	2.3
3	L	447	TYR	2.3
3	I	533	ILE	2.3
1	G	85	LEU	2.3
1	G	536	LYS	2.3
1	G	471	MET	2.3
3	C	559	ASP	2.3
3	I	260	ASP	2.3
3	C	599	GLU	2.3
2	H	582	LYS	2.3
2	K	696	PHE	2.3
2	B	724	MET	2.3
3	C	460	LEU	2.3
1	D	378	PHE	2.3
2	E	49	TYR	2.3
3	C	107	PHE	2.3
3	C	443	ILE	2.3
3	L	635	HIS	2.3
2	B	721	ARG	2.3
1	A	499	ASP	2.3
2	K	352	LYS	2.3
3	I	82	LEU	2.3
3	L	665	VAL	2.3
1	G	103	VAL	2.3
2	E	190	VAL	2.3
3	L	617	ARG	2.3
3	F	656	ARG	2.3
1	D	95	PHE	2.3
2	B	662	PHE	2.2
3	F	109	GLY	2.2
1	G	379	PRO	2.2
2	E	724	MET	2.2
1	A	46	CYS	2.2
2	B	128	GLY	2.2
2	H	190	VAL	2.2
2	K	632	PHE	2.2
3	C	715	CYS	2.2
3	I	421	ASP	2.2
3	L	408	ARG	2.2

*Continued on next page...*

*Continued from previous page...*

<b>Mol</b>	<b>Chain</b>	<b>Res</b>	<b>Type</b>	<b>RSRZ</b>
1	A	120	PHE	2.2
1	G	690	ARG	2.2
3	C	74	PRO	2.2
3	C	426	ALA	2.2
1	J	355	LEU	2.2
3	C	622	LEU	2.2
1	D	132	PHE	2.2
3	C	589	LYS	2.2
1	G	359	VAL	2.2
1	J	54	SER	2.2
3	I	612	LYS	2.2
3	C	595	TYR	2.2
2	E	723	LYS	2.2
3	L	353	LYS	2.2
1	D	209	MET	2.2
3	F	1	MET	2.2
1	G	494	HIS	2.2
3	L	15	CYS	2.2
3	L	439	LEU	2.2
3	L	738	VAL	2.2
1	G	700	LYS	2.2
2	B	714	ILE	2.2
1	G	692	ASN	2.2
1	J	680	ASN	2.2
3	C	690	ALA	2.2
2	B	718	LEU	2.2
3	L	406	ARG	2.2
3	L	748	ARG	2.2
2	K	462	TRP	2.2
2	H	714	ILE	2.2
3	I	607	ILE	2.2
2	K	619	GLU	2.2
3	I	608	ARG	2.2
3	L	437	THR	2.2
3	L	481	MET	2.2
3	F	81	ALA	2.2
3	C	636	GLU	2.2
3	F	244	GLY	2.2
1	G	259	TYR	2.2
3	L	285	LYS	2.2
1	J	345	ARG	2.2
2	K	676	ARG	2.2

*Continued on next page...*

*Continued from previous page...*

<b>Mol</b>	<b>Chain</b>	<b>Res</b>	<b>Type</b>	<b>RSRZ</b>
3	C	101	CYS	2.2
2	K	306	GLY	2.2
3	L	368	TYR	2.2
3	F	412	MET	2.1
2	H	581	ILE	2.1
1	G	663	PHE	2.1
1	D	235	LYS	2.1
1	G	684	CYS	2.1
2	H	50	SER	2.1
1	A	605	ILE	2.1
3	C	469	ILE	2.1
3	F	649	LYS	2.1
2	E	579	GLU	2.1
3	C	386	PHE	2.1
1	D	198	SER	2.1
3	C	539	ASP	2.1
3	F	260	ASP	2.1
2	E	619	GLU	2.1
1	A	124	GLY	2.1
3	F	603	MET	2.1
3	I	11	TYR	2.1
1	G	697	GLU	2.1
1	J	604	TRP	2.1
3	C	308	GLU	2.1
3	L	594	LEU	2.1
1	G	240	HIS	2.1
2	H	212	ASP	2.1
3	L	74	PRO	2.1
3	I	610	ASN	2.1
2	K	452	ALA	2.1
3	C	533	ILE	2.1
2	H	407	GLY	2.1
2	E	395	LYS	2.1
2	K	681	GLU	2.1
1	G	63	LEU	2.1
1	G	390	ILE	2.1
3	C	55	MET	2.1
3	C	62	ILE	2.1
2	B	744	ARG	2.1
1	D	107	ILE	2.1
2	K	226	ILE	2.1
2	E	236	GLY	2.1

*Continued on next page...*

*Continued from previous page...*

<b>Mol</b>	<b>Chain</b>	<b>Res</b>	<b>Type</b>	<b>RSRZ</b>
1	G	132	PHE	2.1
3	C	582	ILE	2.1
3	L	10	GLU	2.1
1	D	92	CYS	2.1
1	G	54	SER	2.1
2	H	622	ARG	2.1
3	I	453	ILE	2.1
1	A	32	GLU	2.1
3	C	450	MET	2.1
2	H	218	GLU	2.1
2	H	232	ASP	2.1
2	K	457	TRP	2.1
3	L	461	GLU	2.1
2	K	464	ILE	2.1
3	C	722	PRO	2.1
3	I	1	MET	2.1
3	L	651	GLY	2.1
1	G	386	TRP	2.1
3	L	14	LEU	2.1
1	D	177	ASP	2.1
3	C	59	PHE	2.1
3	L	102	ILE	2.1
3	L	416	PHE	2.1
2	E	631	PRO	2.1
2	H	443	GLN	2.1
2	E	84	ASN	2.1
2	B	25	THR	2.0
3	C	656	ARG	2.0
3	C	753	THR	2.0
3	I	487	LYS	2.0
3	C	609	PRO	2.0
3	L	401	GLY	2.0
3	L	745	GLY	2.0
3	C	87	GLU	2.0
2	K	749	ALA	2.0
3	C	492	SER	2.0
2	K	717	LYS	2.0
3	C	580	ASN	2.0
3	F	540	LYS	2.0
1	G	463	ALA	2.0
2	K	389	LEU	2.0
3	C	561	LYS	2.0

*Continued on next page...*

*Continued from previous page...*

Mol	Chain	Res	Type	RSRZ
2	H	220	LEU	2.0
3	I	461	GLU	2.0
2	E	71	CYS	2.0
3	L	474	PRO	2.0
3	I	535	ASP	2.0
3	L	515	GLU	2.0
1	G	95	PHE	2.0
3	C	729	LEU	2.0
2	B	725	LYS	2.0

## 6.2 Non-standard residues in protein, DNA, RNA chains [i](#)

There are no non-standard protein/DNA/RNA residues in this entry.

## 6.3 Carbohydrates [i](#)

There are no carbohydrates in this entry.

## 6.4 Ligands [i](#)

There are no ligands in this entry.

## 6.5 Other polymers [i](#)

There are no such residues in this entry.