



# Full wwPDB X-ray Structure Validation Report ⓘ

May 26, 2020 – 04:18 am BST

PDB ID : 5L8E  
Title : Structure of UAF1  
Authors : Dharadhar, S.; Sixma, T.  
Deposited on : 2016-06-07  
Resolution : 2.30 Å(reported)

This is a Full wwPDB X-ray Structure Validation Report for a publicly released PDB entry.

We welcome your comments at [validation@mail.wwpdb.org](mailto:validation@mail.wwpdb.org)

A user guide is available at

<https://www.wwpdb.org/validation/2017/XrayValidationReportHelp>

with specific help available everywhere you see the ⓘ symbol.

---

The following versions of software and data (see [references ⓘ](#)) were used in the production of this report:

MolProbity : 4.02b-467  
Mogul : 1.8.5 (274361), CSD as541be (2020)  
Xtriage (Phenix) : 1.13  
EDS : 2.11  
Percentile statistics : 20191225.v01 (using entries in the PDB archive December 25th 2019)  
Refmac : 5.8.0158  
CCP4 : 7.0.044 (Gargrove)  
Ideal geometry (proteins) : Engh & Huber (2001)  
Ideal geometry (DNA, RNA) : Parkinson et al. (1996)  
Validation Pipeline (wwPDB-VP) : 2.11

# 1 Overall quality at a glance

The following experimental techniques were used to determine the structure:

*X-RAY DIFFRACTION*

The reported resolution of this entry is 2.30 Å.

Percentile scores (ranging between 0-100) for global validation metrics of the entry are shown in the following graphic. The table shows the number of entries on which the scores are based.

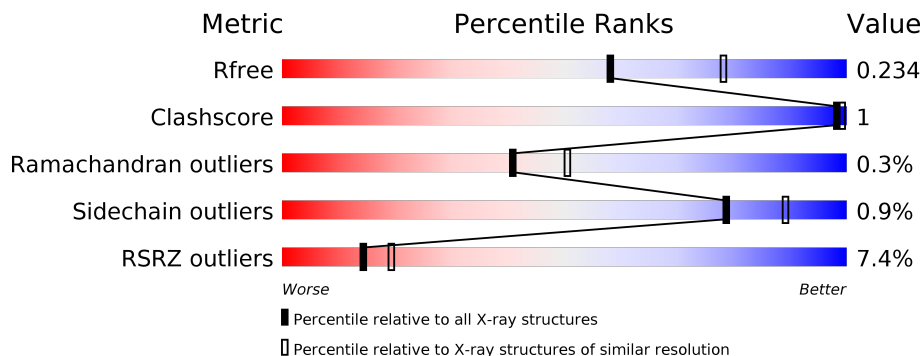

Metric	Whole archive (#Entries)	Similar resolution (#Entries, resolution range(Å))
$R_{free}$	130704	5042 (2.30-2.30)
Clashscore	141614	5643 (2.30-2.30)
Ramachandran outliers	138981	5575 (2.30-2.30)
Sidechain outliers	138945	5575 (2.30-2.30)
RSRZ outliers	127900	4938 (2.30-2.30)

The table below summarises the geometric issues observed across the polymeric chains and their fit to the electron density. The red, orange, yellow and green segments on the lower bar indicate the fraction of residues that contain outliers for  $\geq 3$ , 2, 1 and 0 types of geometric quality criteria respectively. A grey segment represents the fraction of residues that are not modelled. The numeric value for each fraction is indicated below the corresponding segment, with a dot representing fractions  $\leq 5\%$ . The upper red bar (where present) indicates the fraction of residues that have poor fit to the electron density. The numeric value is given above the bar.

Mol	Chain	Length	Quality of chain
1	A	580	 6% 88% 11%
1	B	580	 7% 86% 11%
2	C	5	 100%

The following table lists non-polymeric compounds, carbohydrate monomers and non-standard residues in protein, DNA, RNA chains that are outliers for geometric or electron-density-fit criteria:

Mol	Type	Chain	Res	Chirality	Geometry	Clashes	Electron density
3	GOL	A	602	-	-	-	X

## 2 Entry composition i

There are 4 unique types of molecules in this entry. The entry contains 8582 atoms, of which 0 are hydrogens and 0 are deuteriums.

In the tables below, the ZeroOcc column contains the number of atoms modelled with zero occupancy, the AltConf column contains the number of residues with at least one atom in alternate conformation and the Trace column contains the number of residues modelled with at most 2 atoms.

- Molecule 1 is a protein called WD repeat-containing protein 48.

Mol	Chain	Residues	Atoms					ZeroOcc	AltConf	Trace
			Total	C	N	O	S			
1	A	517	4084	2575	724	762	23	0	1	0
1	B	517	4081	2574	723	761	23	0	1	0

There are 18 discrepancies between the modelled and reference sequences:

Chain	Residue	Modelled	Actual	Comment	Reference
A	1	TRP	-	expression tag	UNP Q8TAF3
A	2	SER	-	expression tag	UNP Q8TAF3
A	3	HIS	-	expression tag	UNP Q8TAF3
A	4	PRO	-	expression tag	UNP Q8TAF3
A	5	GLN	-	expression tag	UNP Q8TAF3
A	6	PHE	-	expression tag	UNP Q8TAF3
A	7	GLU	-	expression tag	UNP Q8TAF3
A	8	LYS	-	expression tag	UNP Q8TAF3
A	369	PHE	LEU	conflict	UNP Q8TAF3
B	1	TRP	-	expression tag	UNP Q8TAF3
B	2	SER	-	expression tag	UNP Q8TAF3
B	3	HIS	-	expression tag	UNP Q8TAF3
B	4	PRO	-	expression tag	UNP Q8TAF3
B	5	GLN	-	expression tag	UNP Q8TAF3
B	6	PHE	-	expression tag	UNP Q8TAF3
B	7	GLU	-	expression tag	UNP Q8TAF3
B	8	LYS	-	expression tag	UNP Q8TAF3
B	369	PHE	LEU	conflict	UNP Q8TAF3

- Molecule 2 is a protein called Unknown.

Mol	Chain	Residues	Atoms				ZeroOcc	AltConf	Trace
			Total	C	N	O			
2	C	5	23	13	5	5	0	0	0

- Molecule 3 is GLYCEROL (three-letter code: GOL) (formula: C<sub>3</sub>H<sub>8</sub>O<sub>3</sub>).



Mol	Chain	Residues	Atoms	ZeroOcc	AltConf
3	A	1	Total C O 6 3 3	0	0
3	A	1	Total C O 6 3 3	0	0
3	A	1	Total C O 6 3 3	0	0
3	A	1	Total C O 6 3 3	0	0
3	A	1	Total C O 6 3 3	0	0
3	A	1	Total C O 6 3 3	0	0
3	A	1	Total C O 6 3 3	0	0
3	B	1	Total C O 6 3 3	0	0
3	B	1	Total C O 6 3 3	0	0
3	B	1	Total C O 6 3 3	0	0
3	B	1	Total C O 6 3 3	0	0
3	B	1	Total C O 6 3 3	0	0
3	B	1	Total C O 6 3 3	0	0

*Continued on next page...*

*Continued from previous page...*

Mol	Chain	Residues	Atoms			ZeroOcc	AltConf
3	B	1	Total	C	O	0	0
			6	3	3		

- Molecule 4 is water.

Mol	Chain	Residues	Atoms		ZeroOcc	AltConf
4	A	147	Total	O	0	0
			147	147		
4	B	163	Total	O	0	0
			163	163		

### 3 Residue-property plots [i](#)

These plots are drawn for all protein, RNA and DNA chains in the entry. The first graphic for a chain summarises the proportions of the various outlier classes displayed in the second graphic. The second graphic shows the sequence view annotated by issues in geometry and electron density. Residues are color-coded according to the number of geometric quality criteria for which they contain at least one outlier: green = 0, yellow = 1, orange = 2 and red = 3 or more. A red dot above a residue indicates a poor fit to the electron density ( $RSRZ > 2$ ). Stretches of 2 or more consecutive residues without any outlier are shown as a green connector. Residues present in the sample, but not in the model, are shown in grey.

- Molecule 1: WD repeat-containing protein 48

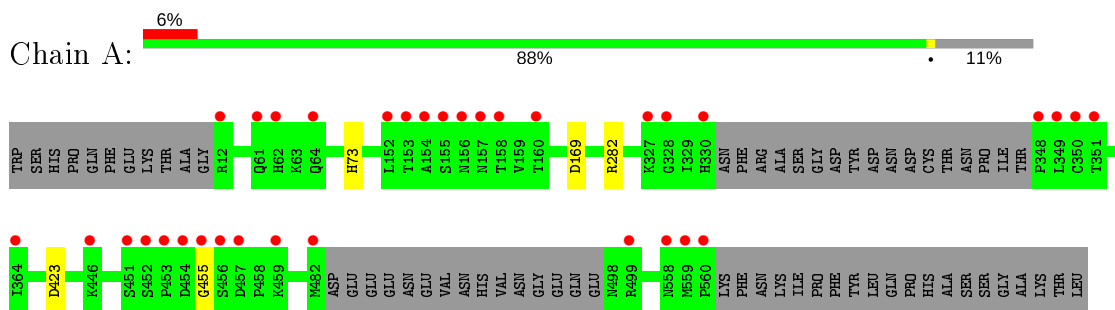

- Molecule 1: WD repeat-containing protein 48

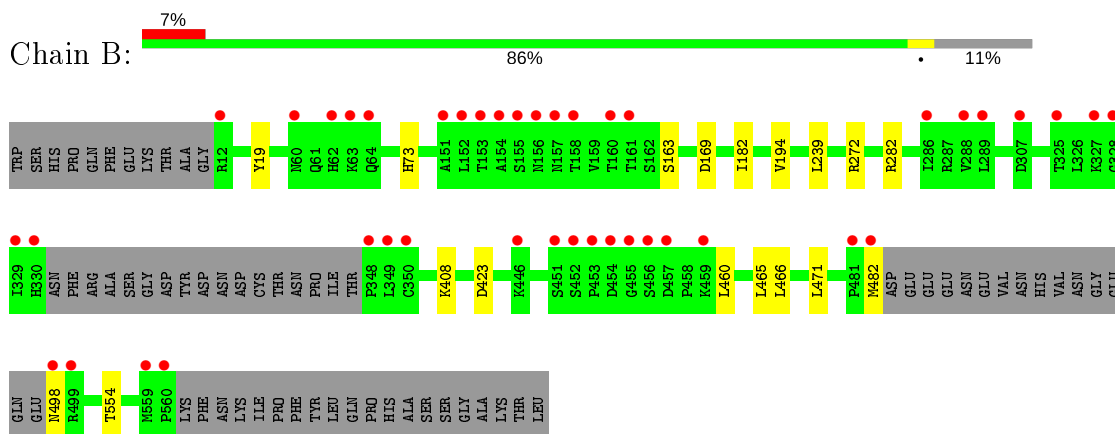

- Molecule 2: Unknown



There are no outlier residues recorded for this chain.

## 4 Data and refinement statistics

Property	Value	Source
Space group	P 2 21 21	Depositor
Cell constants a, b, c, $\alpha$ , $\beta$ , $\gamma$	73.30Å 131.60Å 148.67Å 90.00° 90.00° 90.00°	Depositor
Resolution (Å)	49.00 – 2.30 48.97 – 2.30	Depositor EDS
% Data completeness (in resolution range)	99.6 (49.00-2.30) 99.6 (48.97-2.30)	Depositor EDS
$R_{merge}$	0.05	Depositor
$R_{sym}$	(Not available)	Depositor
$\langle I/\sigma(I) \rangle$ <sup>1</sup>	1.45 (at 2.29Å)	Xtrriage
Refinement program	REFMAC 5.8.0151	Depositor
R, $R_{free}$	0.185 , 0.224 0.192 , 0.234	Depositor DCC
$R_{free}$ test set	3201 reflections (4.96%)	wwPDB-VP
Wilson B-factor (Å <sup>2</sup> )	49.2	Xtrriage
Anisotropy	0.403	Xtrriage
Bulk solvent $k_{sol}$ (e/Å <sup>3</sup> ), $B_{sol}$ (Å <sup>2</sup> )	0.36 , 44.7	EDS
L-test for twinning <sup>2</sup>	$\langle  L  \rangle = 0.49$ , $\langle L^2 \rangle = 0.33$	Xtrriage
Estimated twinning fraction	No twinning to report.	Xtrriage
$F_o, F_c$ correlation	0.96	EDS
Total number of atoms	8582	wwPDB-VP
Average B, all atoms (Å <sup>2</sup> )	58.0	wwPDB-VP

Xtrriage's analysis on translational NCS is as follows: *The largest off-origin peak in the Patterson function is 3.30% of the height of the origin peak. No significant pseudotranslation is detected.*

<sup>1</sup>Intensities estimated from amplitudes.

<sup>2</sup>Theoretical values of  $\langle |L| \rangle$ ,  $\langle L^2 \rangle$  for acentric reflections are 0.5, 0.333 respectively for untwinned datasets, and 0.375, 0.2 for perfectly twinned datasets.



## 5 Model quality [i](#)

### 5.1 Standard geometry [i](#)

Bond lengths and bond angles in the following residue types are not validated in this section: GOL

The Z score for a bond length (or angle) is the number of standard deviations the observed value is removed from the expected value. A bond length (or angle) with  $|Z| > 5$  is considered an outlier worth inspection. RMSZ is the root-mean-square of all Z scores of the bond lengths (or angles).

Mol	Chain	Bond lengths		Bond angles	
		RMSZ	# Z  >5	RMSZ	# Z  >5
1	A	0.37	0/4168	0.64	0/5655
1	B	0.38	0/4168	0.63	0/5655
All	All	0.38	0/8336	0.64	0/11310

There are no bond length outliers.

There are no bond angle outliers.

There are no chirality outliers.

There are no planarity outliers.

### 5.2 Too-close contacts [i](#)

In the following table, the Non-H and H(model) columns list the number of non-hydrogen atoms and hydrogen atoms in the chain respectively. The H(added) column lists the number of hydrogen atoms added and optimized by MolProbity. The Clashes column lists the number of clashes within the asymmetric unit, whereas Symm-Clashes lists symmetry related clashes.

Mol	Chain	Non-H	H(model)	H(added)	Clashes	Symm-Clashes
1	A	4084	0	4086	0	0
1	B	4081	0	4087	10	0
2	C	23	0	5	0	0
3	A	42	0	56	0	0
3	B	42	0	56	0	0
4	A	147	0	0	0	0
4	B	163	0	0	2	0
All	All	8582	0	8290	10	0

The all-atom clashscore is defined as the number of clashes found per 1000 atoms (including hydrogen atoms). The all-atom clashscore for this structure is 1.

All (10) close contacts within the same asymmetric unit are listed below, sorted by their clash magnitude.

Atom-1	Atom-2	Interatomic distance (Å)	Clash overlap (Å)
1:B:272[B]:ARG:HG3	1:B:272[B]:ARG:HH11	1.55	0.71
1:B:272[B]:ARG:NH1	1:B:272[B]:ARG:HG3	2.15	0.61
1:B:498:ASN:N	4:B:702:HOH:O	2.49	0.45
1:B:460:LEU:HB3	1:B:465:LEU:HD11	1.99	0.45
1:B:471:LEU:HD12	1:B:554:THR:HG21	1.99	0.44
1:B:408:LYS:NZ	4:B:704:HOH:O	2.53	0.42
1:B:182:ILE:HD11	1:B:194:VAL:HG11	2.02	0.41
1:B:182:ILE:HD13	1:B:239:LEU:HD13	2.03	0.41
1:B:272[B]:ARG:CG	1:B:272[B]:ARG:HH11	2.28	0.41
1:B:19:TYR:CE1	1:B:466:LEU:HD21	2.57	0.40

There are no symmetry-related clashes.

## 5.3 Torsion angles [i](#)

### 5.3.1 Protein backbone [i](#)

In the following table, the Percentiles column shows the percent Ramachandran outliers of the chain as a percentile score with respect to all X-ray entries followed by that with respect to entries of similar resolution.

The Analysed column shows the number of residues for which the backbone conformation was analysed, and the total number of residues.

Mol	Chain	Analysed	Favoured	Allowed	Outliers	Percentiles	
1	A	512/580 (88%)	497 (97%)	13 (2%)	2 (0%)	34	42
1	B	512/580 (88%)	499 (98%)	12 (2%)	1 (0%)	47	58
All	All	1024/1160 (88%)	996 (97%)	25 (2%)	3 (0%)	41	50

All (3) Ramachandran outliers are listed below:

Mol	Chain	Res	Type
1	A	73	HIS
1	B	73	HIS
1	A	455	GLY

### 5.3.2 Protein sidechains [i](#)

In the following table, the Percentiles column shows the percent sidechain outliers of the chain as a percentile score with respect to all X-ray entries followed by that with respect to entries of similar resolution.

The Analysed column shows the number of residues for which the sidechain conformation was analysed, and the total number of residues.

Mol	Chain	Analysed	Rotameric	Outliers	Percentiles	
1	A	454/508 (89%)	451 (99%)	3 (1%)	84	92
1	B	454/508 (89%)	449 (99%)	5 (1%)	73	86
All	All	908/1016 (89%)	900 (99%)	8 (1%)	78	89

All (8) residues with a non-rotameric sidechain are listed below:

Mol	Chain	Res	Type
1	A	169	ASP
1	A	282	ARG
1	A	423	ASP
1	B	163	SER
1	B	169	ASP
1	B	282	ARG
1	B	423	ASP
1	B	482	MET

Some sidechains can be flipped to improve hydrogen bonding and reduce clashes. All (2) such sidechains are listed below:

Mol	Chain	Res	Type
1	A	73	HIS
1	B	73	HIS

### 5.3.3 RNA [i](#)

There are no RNA molecules in this entry.

## 5.4 Non-standard residues in protein, DNA, RNA chains [i](#)

There are no non-standard protein/DNA/RNA residues in this entry.

## 5.5 Carbohydrates [i](#)

There are no carbohydrates in this entry.

## 5.6 Ligand geometry [i](#)

14 ligands are modelled in this entry.

In the following table, the Counts columns list the number of bonds (or angles) for which Mogul statistics could be retrieved, the number of bonds (or angles) that are observed in the model and the number of bonds (or angles) that are defined in the Chemical Component Dictionary. The Link column lists molecule types, if any, to which the group is linked. The Z score for a bond length (or angle) is the number of standard deviations the observed value is removed from the expected value. A bond length (or angle) with  $|Z| > 2$  is considered an outlier worth inspection. RMSZ is the root-mean-square of all Z scores of the bond lengths (or angles).

Mol	Type	Chain	Res	Link	Bond lengths			Bond angles		
					Counts	RMSZ	# Z  > 2	Counts	RMSZ	# Z  > 2
3	GOL	A	604	-	5,5,5	0.29	0	5,5,5	0.15	0
3	GOL	B	606	-	5,5,5	0.39	0	5,5,5	0.29	0
3	GOL	B	605	-	5,5,5	0.36	0	5,5,5	0.16	0
3	GOL	B	602	-	5,5,5	0.47	0	5,5,5	0.33	0
3	GOL	B	601	-	5,5,5	0.44	0	5,5,5	0.33	0
3	GOL	A	605	-	5,5,5	0.32	0	5,5,5	0.08	0
3	GOL	A	606	-	5,5,5	0.41	0	5,5,5	0.20	0
3	GOL	A	601	-	5,5,5	0.46	0	5,5,5	0.61	0
3	GOL	B	604	-	5,5,5	0.36	0	5,5,5	0.30	0
3	GOL	A	602	-	5,5,5	0.46	0	5,5,5	0.27	0
3	GOL	B	607	-	5,5,5	0.39	0	5,5,5	0.34	0
3	GOL	A	607	-	5,5,5	0.30	0	5,5,5	0.36	0
3	GOL	B	603	-	5,5,5	0.33	0	5,5,5	0.25	0
3	GOL	A	603	-	5,5,5	0.39	0	5,5,5	0.46	0

In the following table, the Chirals column lists the number of chiral outliers, the number of chiral centers analysed, the number of these observed in the model and the number defined in the Chemical Component Dictionary. Similar counts are reported in the Torsion and Rings columns. '-' means no outliers of that kind were identified.

Mol	Type	Chain	Res	Link	Chirals	Torsions	Rings
3	GOL	A	604	-	-	2/4/4/4	-
3	GOL	B	606	-	-	2/4/4/4	-
3	GOL	B	605	-	-	2/4/4/4	-
3	GOL	B	602	-	-	4/4/4/4	-
3	GOL	B	601	-	-	4/4/4/4	-

*Continued on next page...*

*Continued from previous page...*

Mol	Type	Chain	Res	Link	Chirals	Torsions	Rings
3	GOL	A	605	-	-	0/4/4/4	-
3	GOL	A	606	-	-	0/4/4/4	-
3	GOL	A	601	-	-	4/4/4/4	-
3	GOL	B	604	-	-	2/4/4/4	-
3	GOL	A	602	-	-	2/4/4/4	-
3	GOL	B	607	-	-	2/4/4/4	-
3	GOL	A	607	-	-	0/4/4/4	-
3	GOL	B	603	-	-	1/4/4/4	-
3	GOL	A	603	-	-	4/4/4/4	-

There are no bond length outliers.

There are no bond angle outliers.

There are no chirality outliers.

All (29) torsion outliers are listed below:

Mol	Chain	Res	Type	Atoms
3	B	606	GOL	O1-C1-C2-C3
3	B	601	GOL	C1-C2-C3-O3
3	A	601	GOL	C1-C2-C3-O3
3	B	604	GOL	O1-C1-C2-C3
3	A	602	GOL	O1-C1-C2-C3
3	B	607	GOL	C1-C2-C3-O3
3	A	603	GOL	C1-C2-C3-O3
3	A	602	GOL	O1-C1-C2-O2
3	A	604	GOL	O1-C1-C2-C3
3	B	605	GOL	C1-C2-C3-O3
3	B	602	GOL	O1-C1-C2-C3
3	B	602	GOL	C1-C2-C3-O3
3	B	601	GOL	O1-C1-C2-C3
3	A	601	GOL	O1-C1-C2-C3
3	A	604	GOL	O1-C1-C2-O2
3	B	606	GOL	O1-C1-C2-O2
3	B	605	GOL	O2-C2-C3-O3
3	B	602	GOL	O1-C1-C2-O2
3	B	601	GOL	O1-C1-C2-O2
3	A	601	GOL	O1-C1-C2-O2
3	A	601	GOL	O2-C2-C3-O3
3	B	604	GOL	O1-C1-C2-O2
3	A	603	GOL	O2-C2-C3-O3
3	B	602	GOL	O2-C2-C3-O3

*Continued on next page...*

*Continued from previous page...*

Mol	Chain	Res	Type	Atoms
3	B	607	GOL	O2-C2-C3-O3
3	B	603	GOL	O2-C2-C3-O3
3	A	603	GOL	O1-C1-C2-C3
3	B	601	GOL	O2-C2-C3-O3
3	A	603	GOL	O1-C1-C2-O2

There are no ring outliers.

No monomer is involved in short contacts.

## 5.7 Other polymers [i](#)

There are no such residues in this entry.

## 5.8 Polymer linkage issues [i](#)

There are no chain breaks in this entry.

## 6 Fit of model and data

### 6.1 Protein, DNA and RNA chains

In the following table, the column labelled ‘#RSRZ> 2’ contains the number (and percentage) of RSRZ outliers, followed by percent RSRZ outliers for the chain as percentile scores relative to all X-ray entries and entries of similar resolution. The OWAB column contains the minimum, median, 95<sup>th</sup> percentile and maximum values of the occupancy-weighted average B-factor per residue. The column labelled ‘Q< 0.9’ lists the number of (and percentage) of residues with an average occupancy less than 0.9.

Mol	Chain	Analysed	<RSRZ>	#RSRZ>2	OWAB(Å <sup>2</sup> )	Q<0.9
1	A	517/580 (89%)	0.17	34 (6%) 18 23	38, 52, 101, 149	0
1	B	517/580 (89%)	0.36	42 (8%) 12 16	38, 53, 107, 149	0
2	C	0/5	-	-	-	-
All	All	1034/1165 (88%)	0.26	76 (7%) 14 19	38, 53, 104, 149	0

All (76) RSRZ outliers are listed below:

Mol	Chain	Res	Type	RSRZ
1	B	155	SER	10.2
1	A	454	ASP	9.5
1	B	453	PRO	9.0
1	B	454	ASP	8.7
1	A	452	SER	8.1
1	A	453	PRO	7.6
1	B	154	ALA	7.0
1	B	156	ASN	6.8
1	B	455	GLY	6.7
1	B	559	MET	6.6
1	B	482	MET	6.4
1	A	455	GLY	6.4
1	A	12	ARG	5.9
1	B	456	SER	5.7
1	B	158	THR	5.4
1	A	560	PRO	5.3
1	B	330	HIS	5.2
1	A	559	MET	5.2
1	B	452	SER	5.2
1	B	62	HIS	5.1
1	A	456	SER	5.1
1	B	152	LEU	4.9
1	A	62	HIS	4.8

*Continued on next page...*

*Continued from previous page...*

<b>Mol</b>	<b>Chain</b>	<b>Res</b>	<b>Type</b>	<b>RSRZ</b>
1	B	560	PRO	4.8
1	A	349	LEU	4.6
1	B	64	GLN	4.5
1	A	155	SER	4.4
1	B	350	CYS	4.3
1	B	153	THR	4.2
1	B	348	PRO	4.2
1	B	157	ASN	4.2
1	A	330	HIS	4.1
1	B	481	PRO	4.0
1	A	157	ASN	4.0
1	A	348	PRO	4.0
1	B	349	LEU	3.9
1	B	327	LYS	3.8
1	B	307	ASP	3.8
1	B	63	LYS	3.7
1	B	328	GLY	3.7
1	A	482	MET	3.5
1	A	328	GLY	3.5
1	B	151	ALA	3.5
1	B	451	SER	3.4
1	B	459	LYS	3.4
1	B	499	ARG	3.3
1	A	446	LYS	3.3
1	A	160	THR	3.1
1	B	446	LYS	3.1
1	A	64	GLN	3.0
1	B	12	ARG	3.0
1	B	288	VAL	3.0
1	A	351	THR	3.0
1	A	61	GLN	2.8
1	B	60	ASN	2.8
1	A	153	THR	2.7
1	A	350	CYS	2.7
1	A	457	ASP	2.5
1	B	161	THR	2.5
1	B	457	ASP	2.5
1	B	498	ASN	2.4
1	A	459	LYS	2.4
1	A	327	LYS	2.4
1	B	286	ILE	2.4
1	B	329	ILE	2.3

*Continued on next page...*



*Continued from previous page...*

Mol	Chain	Res	Type	RSRZ
1	A	499	ARG	2.3
1	B	160	THR	2.2
1	A	156	ASN	2.2
1	A	364	ILE	2.2
1	A	152	LEU	2.2
1	B	289	LEU	2.1
1	A	154	ALA	2.1
1	A	158	THR	2.0
1	A	558	ASN	2.0
1	A	451	SER	2.0
1	B	325	THR	2.0

## 6.2 Non-standard residues in protein, DNA, RNA chains [i](#)

There are no non-standard protein/DNA/RNA residues in this entry.

## 6.3 Carbohydrates [i](#)

There are no carbohydrates in this entry.

## 6.4 Ligands [i](#)

In the following table, the Atoms column lists the number of modelled atoms in the group and the number defined in the chemical component dictionary. The B-factors column lists the minimum, median, 95<sup>th</sup> percentile and maximum values of B factors of atoms in the group. The column labelled 'Q< 0.9' lists the number of atoms with occupancy less than 0.9.

Mol	Type	Chain	Res	Atoms	RSCC	RSR	B-factors(Å <sup>2</sup> )	Q<0.9
3	GOL	A	602	6/6	0.61	0.50	74,88,92,93	0
3	GOL	B	606	6/6	0.67	0.29	87,89,90,91	0
3	GOL	B	605	6/6	0.70	0.20	81,86,87,87	0
3	GOL	A	604	6/6	0.71	0.30	97,103,108,115	0
3	GOL	A	601	6/6	0.73	0.40	84,87,89,90	0
3	GOL	A	603	6/6	0.75	0.22	72,75,76,78	0
3	GOL	B	601	6/6	0.77	0.33	81,83,84,84	0
3	GOL	A	607	6/6	0.79	0.18	79,81,83,84	0
3	GOL	B	602	6/6	0.82	0.49	87,89,91,92	0
3	GOL	B	603	6/6	0.83	0.15	82,89,89,90	0
3	GOL	B	607	6/6	0.86	0.14	62,66,68,69	0
3	GOL	B	604	6/6	0.87	0.19	68,70,71,72	0

*Continued on next page...*

*Continued from previous page...*

Mol	Type	Chain	Res	Atoms	RSCC	RSR	B-factors( $\text{\AA}^2$ )	Q<0.9
3	GOL	A	606	6/6	0.87	0.15	72,73,74,75	0
3	GOL	A	605	6/6	0.89	0.19	89,93,95,95	0

## 6.5 Other polymers [i](#)

There are no such residues in this entry.