



Full wwPDB X-ray Structure Validation Report ⓘ

Feb 15, 2024 – 07:01 PM EST

PDB ID : 3R5A
Title : Pseudomonas aeruginosa DapD (PA3666) in complex with D-2-aminopimelate
Authors : Sandalova, T.; Schnell, R.; Schneider, G.
Deposited on : 2011-03-18
Resolution : 1.89 Å(reported)

This is a Full wwPDB X-ray Structure Validation Report for a publicly released PDB entry.

We welcome your comments at validation@mail.wwpdb.org

A user guide is available at

<https://www.wwpdb.org/validation/2017/XrayValidationReportHelp>

with specific help available everywhere you see the ⓘ symbol.

The types of validation reports are described at

<http://www.wwpdb.org/validation/2017/FAQs#types>.

The following versions of software and data (see [references ⓘ](#)) were used in the production of this report:

MolProbity : 4.02b-467
Mogul : 1.8.5 (274361), CSD as541be (2020)
Xtriage (Phenix) : 1.13
EDS : 2.36
Percentile statistics : 20191225.v01 (using entries in the PDB archive December 25th 2019)
Refmac : 5.8.0158
CCP4 : 7.0.044 (Gargrove)
Ideal geometry (proteins) : Engh & Huber (2001)
Ideal geometry (DNA, RNA) : Parkinson et al. (1996)
Validation Pipeline (wwPDB-VP) : 2.36

1 Overall quality at a glance

The following experimental techniques were used to determine the structure:

X-RAY DIFFRACTION

The reported resolution of this entry is 1.89 Å.

Percentile scores (ranging between 0-100) for global validation metrics of the entry are shown in the following graphic. The table shows the number of entries on which the scores are based.

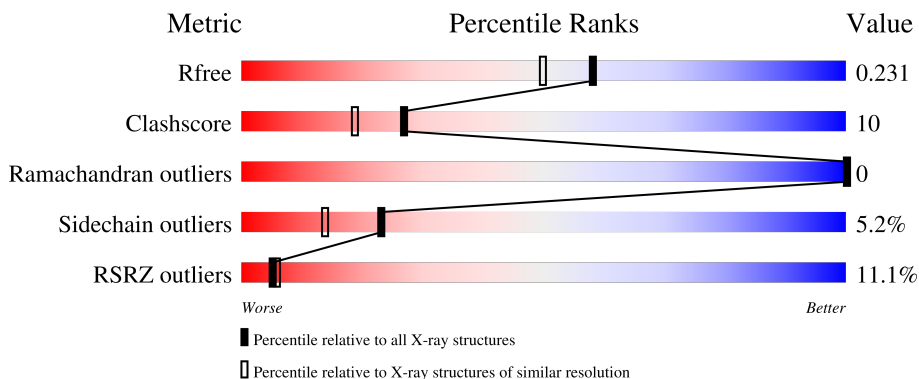

Metric	Whole archive (#Entries)	Similar resolution (#Entries, resolution range(Å))
R_{free}	130704	6207 (1.90-1.90)
Clashscore	141614	6847 (1.90-1.90)
Ramachandran outliers	138981	6760 (1.90-1.90)
Sidechain outliers	138945	6760 (1.90-1.90)
RSRZ outliers	127900	6082 (1.90-1.90)

The table below summarises the geometric issues observed across the polymeric chains and their fit to the electron density. The red, orange, yellow and green segments of the lower bar indicate the fraction of residues that contain outliers for ≥ 3 , 2, 1 and 0 types of geometric quality criteria respectively. A grey segment represents the fraction of residues that are not modelled. The numeric value for each fraction is indicated below the corresponding segment, with a dot representing fractions $\leq 5\%$. The upper red bar (where present) indicates the fraction of residues that have poor fit to the electron density. The numeric value is given above the bar.

Mol	Chain	Length	Quality of chain
1	A	347	 9% 82% 10% • 7%
1	B	347	 11% 73% 16% • 8%
1	C	347	 10% 70% 21% • 7%
1	D	347	 11% 78% 13% • 7%
1	E	347	 10% 73% 15% • 10%

Continued on next page...

Continued from previous page...

Mol	Chain	Length	Quality of chain
1	F	347	

The following table lists non-polymeric compounds, carbohydrate monomers and non-standard residues in protein, DNA, RNA chains that are outliers for geometric or electron-density-fit criteria:

Mol	Type	Chain	Res	Chirality	Geometry	Clashes	Electron density
3	GOL	E	345	-	-	X	-

2 Entry composition [i](#)

There are 4 unique types of molecules in this entry. The entry contains 15195 atoms, of which 0 are hydrogens and 0 are deuteriums.

In the tables below, the ZeroOcc column contains the number of atoms modelled with zero occupancy, the AltConf column contains the number of residues with at least one atom in alternate conformation and the Trace column contains the number of residues modelled with at most 2 atoms.

- Molecule 1 is a protein called Tetrahydrodipicolinate N-succinyletransferase.

Mol	Chain	Residues	Atoms					ZeroOcc	AltConf	Trace
			Total	C	N	O	S			
1	A	321	Total 2364	C 1506	N 406	O 445	S 7	0	0	0
1	B	318	Total 2342	C 1492	N 403	O 440	S 7	0	0	0
1	C	321	Total 2367	C 1506	N 407	O 447	S 7	0	0	0
1	D	321	Total 2364	C 1506	N 406	O 445	S 7	0	0	0
1	E	311	Total 2288	C 1464	N 387	O 430	S 7	0	0	0
1	F	321	Total 2367	C 1506	N 407	O 447	S 7	0	0	0

There are 18 discrepancies between the modelled and reference sequences:

Chain	Residue	Modelled	Actual	Comment	Reference
A	-2	GLY	-	expression tag	UNP Q9Z9H2
A	-1	SER	-	expression tag	UNP Q9Z9H2
A	0	HIS	-	expression tag	UNP Q9Z9H2
B	-2	GLY	-	expression tag	UNP Q9Z9H2
B	-1	SER	-	expression tag	UNP Q9Z9H2
B	0	HIS	-	expression tag	UNP Q9Z9H2
C	-2	GLY	-	expression tag	UNP Q9Z9H2
C	-1	SER	-	expression tag	UNP Q9Z9H2
C	0	HIS	-	expression tag	UNP Q9Z9H2
D	-2	GLY	-	expression tag	UNP Q9Z9H2
D	-1	SER	-	expression tag	UNP Q9Z9H2
D	0	HIS	-	expression tag	UNP Q9Z9H2
E	-2	GLY	-	expression tag	UNP Q9Z9H2
E	-1	SER	-	expression tag	UNP Q9Z9H2
E	0	HIS	-	expression tag	UNP Q9Z9H2
F	-2	GLY	-	expression tag	UNP Q9Z9H2
F	-1	SER	-	expression tag	UNP Q9Z9H2

Continued on next page...

Continued from previous page...

Chain	Residue	Modelled	Actual	Comment	Reference
F	0	HIS	-	expression tag	UNP Q9Z9H2

- Molecule 2 is (2R)-2-aminoheptanedioic acid (three-letter code: P0A) (formula: $C_7H_{13}NO_4$).

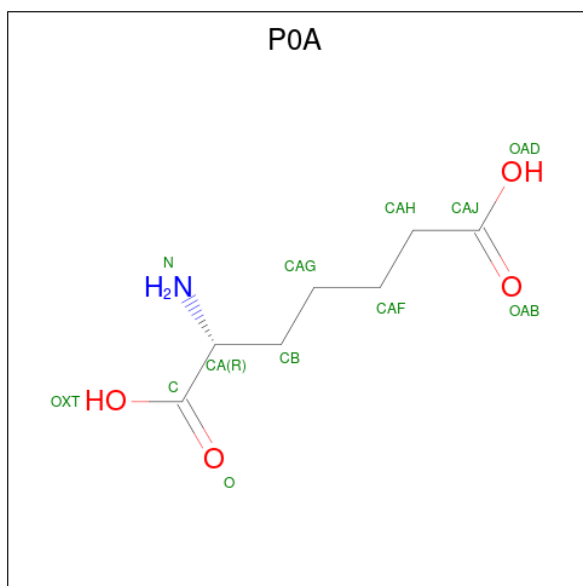

Mol	Chain	Residues	Atoms				ZeroOcc	AltConf
			Total	C	N	O		
2	A	1	Total	C	N	O	0	0
			12	7	1	4		
2	A	1	Total	C	N	O	0	0
			12	7	1	4		
2	C	1	Total	C	N	O	0	0
			12	7	1	4		
2	D	1	Total	C	N	O	0	0
			12	7	1	4		
2	E	1	Total	C	N	O	0	0
			12	7	1	4		
2	F	1	Total	C	N	O	0	0
			12	7	1	4		

- Molecule 3 is GLYCEROL (three-letter code: GOL) (formula: $C_3H_8O_3$).



Mol	Chain	Residues	Atoms	ZeroOcc	AltConf
3	A	1	Total C O 6 3 3	0	0
3	E	1	Total C O 6 3 3	0	0

- Molecule 4 is water.

Mol	Chain	Residues	Atoms	ZeroOcc	AltConf
4	A	175	Total O 175 175	0	0
4	B	192	Total O 192 192	0	0
4	C	143	Total O 143 143	0	0
4	D	172	Total O 172 172	0	0
4	E	212	Total O 212 212	0	0
4	F	125	Total O 125 125	0	0

3 Residue-property plots [i](#)

These plots are drawn for all protein, RNA, DNA and oligosaccharide chains in the entry. The first graphic for a chain summarises the proportions of the various outlier classes displayed in the second graphic. The second graphic shows the sequence view annotated by issues in geometry and electron density. Residues are color-coded according to the number of geometric quality criteria for which they contain at least one outlier: green = 0, yellow = 1, orange = 2 and red = 3 or more. A red dot above a residue indicates a poor fit to the electron density ($RSRZ > 2$). Stretches of 2 or more consecutive residues without any outlier are shown as a green connector. Residues present in the sample, but not in the model, are shown in grey.

- Molecule 1: Tetrahydrodipicolinate N-succinyletransferase

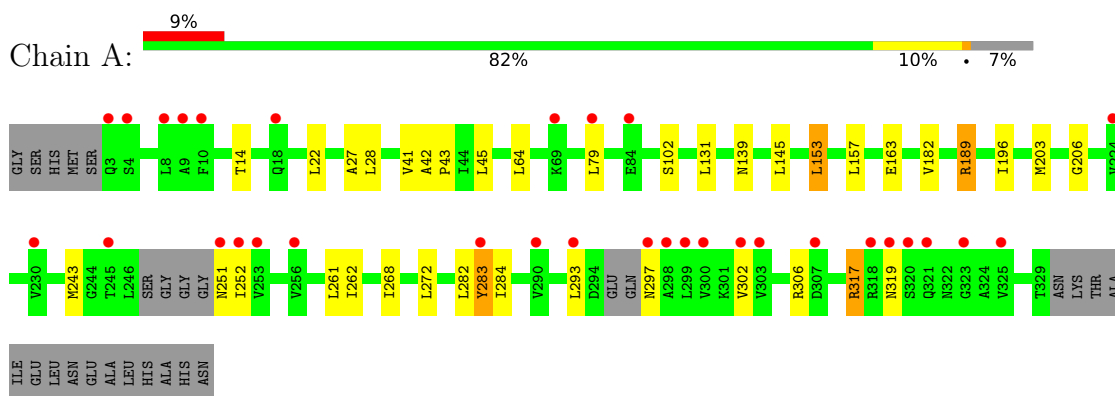

- Molecule 1: Tetrahydrodipicolinate N-succinyletransferase

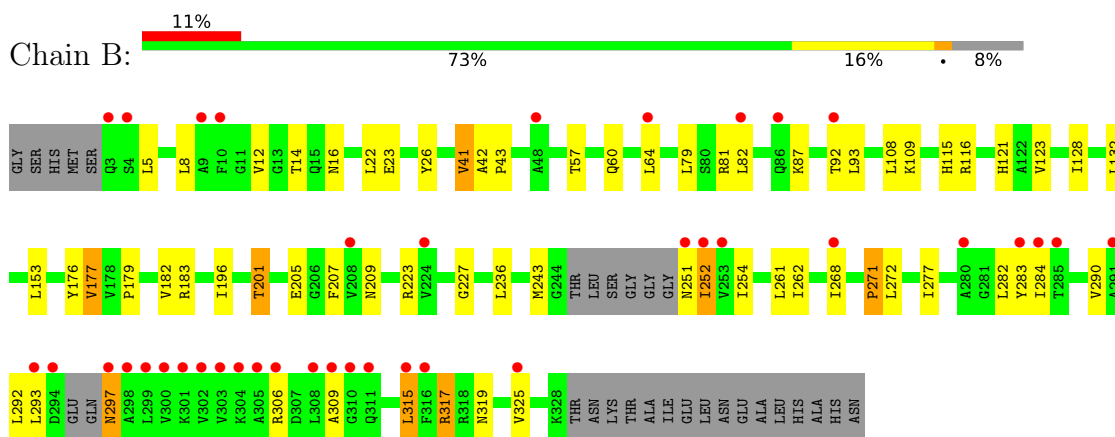

- Molecule 1: Tetrahydrodipicolinate N-succinyletransferase

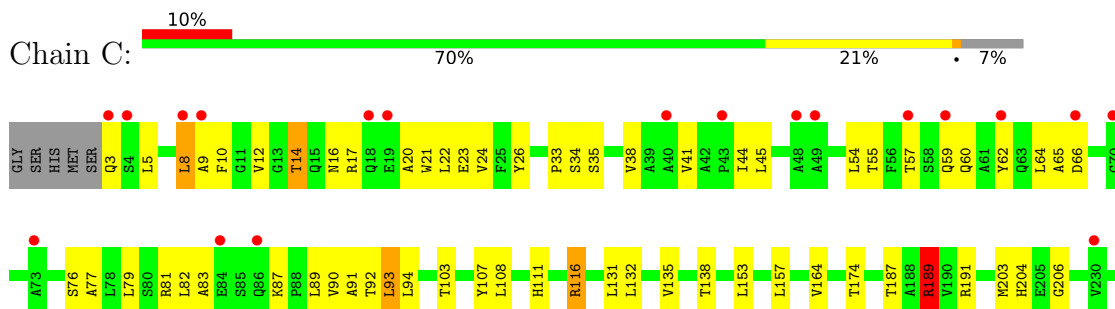

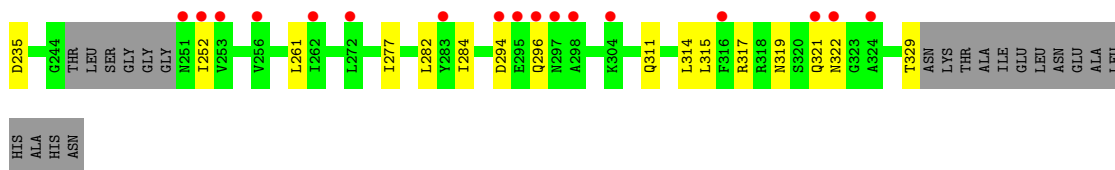

• Molecule 1: Tetrahydrodipicolinate N-succinyletransferase

Chain D: 11% 78% 13% 7%

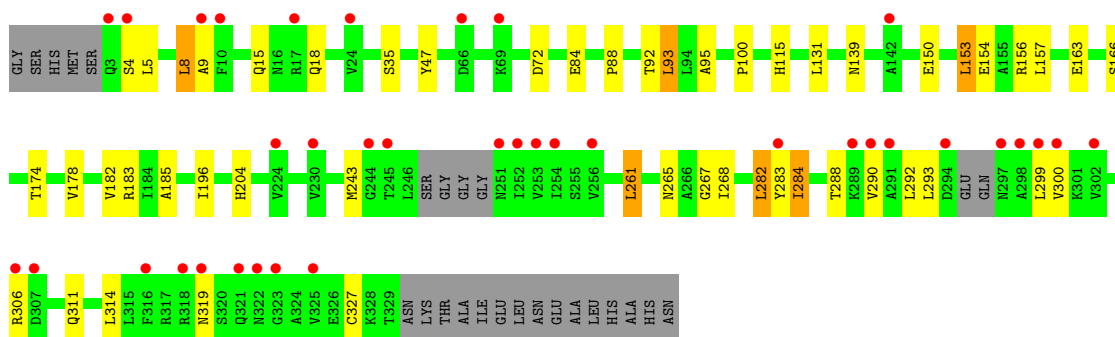

• Molecule 1: Tetrahydrodipicolinate N-succinyletransferase

Chain E: 10% 73% 15% 10%

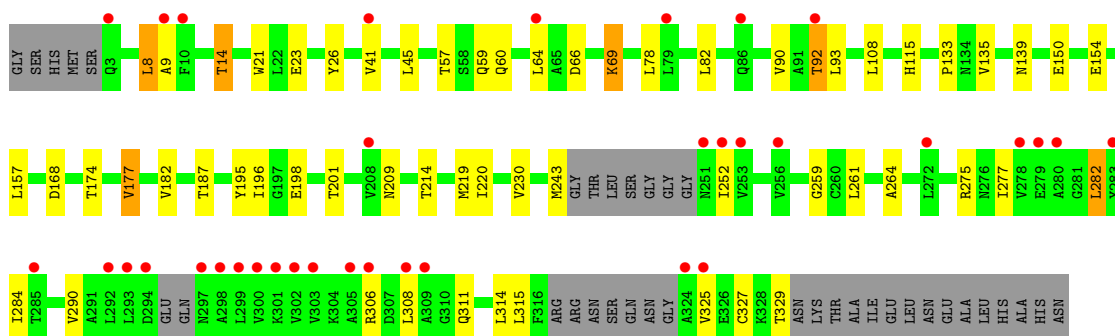

• Molecule 1: Tetrahydrodipicolinate N-succinyletransferase

Chain F: 10% 69% 22% 7%

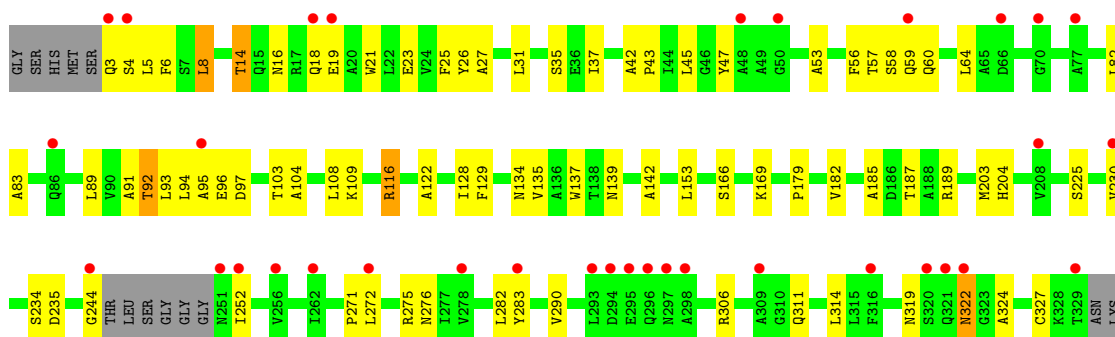

THR
ALA
ILE
GLU
LEU
ASN
GLU
ALA
HIS
HIS
ASN

4 Data and refinement statistics i

Property	Value	Source
Space group	P 1 21 1	Depositor
Cell constants a, b, c, α , β , γ	83.34Å 101.93Å 135.69Å 90.00° 89.97° 90.00°	Depositor
Resolution (Å)	21.83 – 1.89 21.83 – 1.89	Depositor EDS
% Data completeness (in resolution range)	96.1 (21.83-1.89) 98.6 (21.83-1.89)	Depositor EDS
R_{merge}	0.06	Depositor
R_{sym}	0.06	Depositor
$\langle I/\sigma(I) \rangle$ ¹	2.02 (at 1.89Å)	Xtriage
Refinement program	REFMAC 5.5.0109	Depositor
R, R_{free}	0.196 , 0.235 0.197 , 0.231	Depositor DCC
R_{free} test set	9008 reflections (5.04%)	wwPDB-VP
Wilson B-factor (Å ²)	28.9	Xtriage
Anisotropy	0.070	Xtriage
Bulk solvent k_{sol} (e/Å ³), B_{sol} (Å ²)	0.36 , 55.1	EDS
L-test for twinning ²	$\langle L \rangle = 0.50$, $\langle L^2 \rangle = 0.33$	Xtriage
Estimated twinning fraction	0.277 for h,-k,-l	Xtriage
Reported twinning fraction	0.509 for H, K, L 0.491 for h,-k,-l	Depositor
Outliers	0 of 178640 reflections	Xtriage
F_o, F_c correlation	0.95	EDS
Total number of atoms	15195	wwPDB-VP
Average B, all atoms (Å ²)	30.0	wwPDB-VP

Xtriage's analysis on translational NCS is as follows: *The largest off-origin peak in the Patterson function is 4.34% of the height of the origin peak. No significant pseudotranslation is detected.*

¹Intensities estimated from amplitudes.

²Theoretical values of $\langle |L| \rangle$, $\langle L^2 \rangle$ for acentric reflections are 0.5, 0.333 respectively for untwinned datasets, and 0.375, 0.2 for perfectly twinned datasets.

5 Model quality [i](#)

5.1 Standard geometry [i](#)

Bond lengths and bond angles in the following residue types are not validated in this section: GOL, P0A

The Z score for a bond length (or angle) is the number of standard deviations the observed value is removed from the expected value. A bond length (or angle) with $|Z| > 5$ is considered an outlier worth inspection. RMSZ is the root-mean-square of all Z scores of the bond lengths (or angles).

Mol	Chain	Bond lengths		Bond angles	
		RMSZ	# Z >5	RMSZ	# Z >5
1	A	0.42	0/2400	0.58	1/3257 (0.0%)
1	B	0.42	0/2378	0.59	1/3226 (0.0%)
1	C	0.41	0/2404	0.62	3/3263 (0.1%)
1	D	0.42	0/2400	0.58	0/3257
1	E	0.43	0/2323	0.60	0/3153
1	F	0.43	0/2404	0.62	3/3263 (0.1%)
All	All	0.42	0/14309	0.60	8/19419 (0.0%)

There are no bond length outliers.

All (8) bond angle outliers are listed below:

Mol	Chain	Res	Type	Atoms	Z	Observed(°)	Ideal(°)
1	C	116	ARG	NE-CZ-NH2	-7.48	116.56	120.30
1	B	116	ARG	NE-CZ-NH2	-6.31	117.14	120.30
1	A	189	ARG	NE-CZ-NH2	-6.07	117.27	120.30
1	C	189	ARG	NE-CZ-NH2	-5.60	117.50	120.30
1	F	116	ARG	NE-CZ-NH1	5.57	123.08	120.30
1	F	116	ARG	NE-CZ-NH2	-5.56	117.52	120.30
1	C	116	ARG	NE-CZ-NH1	5.40	123.00	120.30
1	F	189	ARG	NE-CZ-NH2	-5.04	117.78	120.30

There are no chirality outliers.

There are no planarity outliers.

5.2 Too-close contacts [i](#)

In the following table, the Non-H and H(model) columns list the number of non-hydrogen atoms and hydrogen atoms in the chain respectively. The H(added) column lists the number of hydrogen

atoms added and optimized by MolProbity. The Clashes column lists the number of clashes within the asymmetric unit, whereas Symm-Clashes lists symmetry-related clashes.

Mol	Chain	Non-H	H(model)	H(added)	Clashes	Symm-Clashes
1	A	2364	0	2420	32	0
1	B	2342	0	2395	50	0
1	C	2367	0	2417	66	0
1	D	2364	0	2420	31	0
1	E	2288	0	2344	53	0
1	F	2367	0	2417	69	0
2	A	24	0	22	3	0
2	C	12	0	11	1	0
2	D	12	0	11	1	0
2	E	12	0	11	2	0
2	F	12	0	11	0	0
3	A	6	0	8	2	0
3	E	6	0	8	5	0
4	A	175	0	0	1	0
4	B	192	0	0	4	0
4	C	143	0	0	3	0
4	D	172	0	0	2	0
4	E	212	0	0	7	0
4	F	125	0	0	4	0
All	All	15195	0	14495	292	0

The all-atom clashscore is defined as the number of clashes found per 1000 atoms (including hydrogen atoms). The all-atom clashscore for this structure is 10.

All (292) close contacts within the same asymmetric unit are listed below, sorted by their clash magnitude.

Atom-1	Atom-2	Interatomic distance (Å)	Clash overlap (Å)
1:F:45:LEU:HD21	1:F:64:LEU:HD11	1.34	1.06
1:E:201:THR:HB	4:E:996:HOH:O	1.63	0.98
1:C:14:THR:HG22	1:C:87:LYS:NZ	1.79	0.98
1:B:14:THR:HG22	1:B:87:LYS:NZ	1.80	0.96
1:F:57:THR:HG22	1:F:60:GLN:NE2	1.81	0.95
1:B:201:THR:HG22	4:B:713:HOH:O	1.67	0.93
1:C:14:THR:HG23	1:C:23:GLU:OE1	1.70	0.91
1:B:41:VAL:HG22	1:B:64:LEU:HD22	1.54	0.90
1:B:268:ILE:HG21	1:B:272:LEU:HD11	1.55	0.89
3:E:345:GOL:H12	1:F:139:ASN:HB3	1.56	0.88
1:F:14:THR:HG22	1:F:23:GLU:OE1	1.73	0.88
1:F:252:ILE:HD12	1:F:252:ILE:O	1.74	0.87

Continued on next page...

Continued from previous page...

Atom-1	Atom-2	Interatomic distance (Å)	Clash overlap (Å)
1:C:14:THR:HG22	1:C:87:LYS:HZ3	1.32	0.87
1:E:41:VAL:HG13	1:E:64:LEU:HD22	1.56	0.87
1:C:22:LEU:HD22	1:C:135:VAL:HG22	1.59	0.85
3:E:345:GOL:H12	1:F:139:ASN:CB	2.08	0.83
1:D:284:ILE:HG22	1:D:288:THR:HG21	1.61	0.82
1:B:14:THR:HG23	1:B:23:GLU:OE2	1.79	0.82
1:E:311:GLN:HB2	1:E:314:LEU:HD11	1.63	0.81
1:C:116:ARG:HD3	4:C:910:HOH:O	1.82	0.79
1:F:94:LEU:HD11	1:F:108:LEU:HD23	1.65	0.78
1:A:252:ILE:HD12	1:A:252:ILE:O	1.84	0.78
1:B:177:VAL:HB	4:B:988:HOH:O	1.83	0.78
1:C:8:LEU:HB2	1:C:93:LEU:HD22	1.65	0.77
1:D:311:GLN:HB2	1:D:314:LEU:HD11	1.66	0.77
1:E:41:VAL:HG13	1:E:64:LEU:CD2	2.15	0.76
1:B:14:THR:HG22	1:B:87:LYS:HZ1	1.49	0.76
1:E:14:THR:HG22	1:E:23:GLU:OE2	1.87	0.74
1:F:5:LEU:HD22	1:F:95:ALA:HA	1.69	0.74
1:F:137:TRP:CZ3	1:F:142:ALA:HB2	2.21	0.74
1:D:8:LEU:HD12	1:D:9:ALA:N	2.05	0.72
1:F:97:ASP:OD1	1:F:109:LYS:NZ	2.21	0.71
1:B:293:LEU:HD13	1:B:297:ASN:HB2	1.72	0.71
1:B:14:THR:HG22	1:B:87:LYS:HZ3	1.52	0.71
1:C:189:ARG:HD3	1:C:206:GLY:O	1.91	0.71
1:F:26:TYR:OH	1:F:92:THR:HG21	1.91	0.71
1:E:264:ALA:HB2	4:E:451:HOH:O	1.91	0.70
1:C:41:VAL:HG22	1:C:64:LEU:HD22	1.72	0.70
1:B:179:PRO:HG2	1:B:182:VAL:HG21	1.74	0.69
1:F:42:ALA:HB3	1:F:43:PRO:HD3	1.74	0.69
1:F:45:LEU:CD2	1:F:64:LEU:HD11	2.17	0.67
1:A:41:VAL:HG22	1:A:64:LEU:HD22	1.77	0.67
1:B:26:TYR:OH	1:B:92:THR:HG21	1.93	0.67
1:E:21:TRP:CH2	1:E:90:VAL:HG13	2.30	0.67
1:A:41:VAL:HG12	1:A:45:LEU:HD12	1.77	0.67
1:E:209:ASN:HD21	2:E:351:P0A:HAF	1.58	0.66
1:E:201:THR:HG21	1:E:219:MET:CE	2.24	0.66
1:E:8:LEU:HB2	1:E:93:LEU:HD22	1.77	0.66
3:E:345:GOL:C1	1:F:139:ASN:HB3	2.24	0.66
1:F:47:TYR:OH	1:F:95:ALA:HB2	1.97	0.64
1:D:182:VAL:HG11	1:D:196:ILE:HG21	1.78	0.64
1:F:92:THR:OG1	1:F:108:LEU:HD22	1.98	0.64
1:B:290:VAL:HG13	1:B:325:VAL:HG12	1.79	0.64

Continued on next page...

Continued from previous page...

Atom-1	Atom-2	Interatomic distance (Å)	Clash overlap (Å)
1:C:294:ASP:O	1:C:296:GLN:O	2.16	0.64
1:F:57:THR:CG2	1:F:60:GLN:NE2	2.58	0.63
1:B:282:LEU:CD2	1:B:284:ILE:HG23	2.29	0.62
1:A:297:ASN:N	4:A:1009:HOH:O	2.33	0.62
1:A:139:ASN:HB2	3:A:346:GOL:H12	1.80	0.62
1:D:100:PRO:O	1:D:131:LEU:HD11	1.99	0.62
1:C:5:LEU:HD22	1:C:94:LEU:O	1.99	0.62
1:F:94:LEU:CD1	1:F:108:LEU:HD23	2.29	0.62
1:F:311:GLN:HB2	1:F:314:LEU:HD11	1.82	0.61
1:E:57:THR:H	1:E:60:GLN:HE21	1.49	0.61
1:B:121:HIS:NE2	1:B:227:GLY:O	2.31	0.60
1:A:182:VAL:HG22	1:A:196:ILE:HG22	1.83	0.60
1:B:205:GLU:OE2	1:C:189:ARG:NH2	2.34	0.60
1:F:45:LEU:HD21	1:F:64:LEU:CD1	2.23	0.60
1:F:57:THR:CG2	1:F:60:GLN:HE21	2.15	0.60
1:F:275:ARG:NH1	4:F:362:HOH:O	2.35	0.60
1:F:14:THR:CG2	1:F:23:GLU:OE1	2.49	0.59
1:A:182:VAL:CG2	1:A:196:ILE:HG22	2.32	0.59
1:E:282:LEU:HD11	1:E:325:VAL:HG13	1.85	0.59
1:E:115:HIS:CD2	1:E:177:VAL:HG11	2.37	0.59
1:E:282:LEU:HD22	1:E:284:ILE:HG23	1.83	0.59
1:C:57:THR:HG23	1:C:60:GLN:NE2	2.18	0.59
1:B:252:ILE:HD13	1:B:254:ILE:HD11	1.85	0.58
1:C:90:VAL:HG22	1:C:92:THR:HG23	1.86	0.58
1:A:14:THR:HG22	1:A:22:LEU:HD12	1.85	0.58
1:C:14:THR:HG22	1:C:87:LYS:HZ1	1.63	0.58
1:B:64:LEU:HB3	1:B:79:LEU:HD13	1.85	0.58
1:F:235:ASP:HB3	4:F:377:HOH:O	2.04	0.57
1:A:268:ILE:HG21	1:A:272:LEU:HD11	1.85	0.57
1:F:252:ILE:HD13	1:F:271:PRO:HD3	1.87	0.57
1:B:128:ILE:HG12	1:B:132:LEU:HD11	1.86	0.57
1:B:207:PHE:HB3	1:B:223:ARG:HG2	1.85	0.57
1:C:108:LEU:O	1:C:108:LEU:HD12	2.05	0.57
1:F:16:ASN:OD1	1:F:18:GLN:N	2.38	0.57
1:E:115:HIS:NE2	1:E:177:VAL:HG11	2.19	0.57
1:E:139:ASN:HB3	3:E:345:GOL:H31	1.87	0.56
1:F:135:VAL:HG11	1:F:142:ALA:HB1	1.87	0.56
1:B:277:ILE:HG21	1:B:315:LEU:HD12	1.86	0.56
1:D:292:LEU:O	1:D:300:VAL:HG22	2.06	0.56
1:B:115:HIS:CE1	1:B:177:VAL:HG11	2.41	0.55
1:C:16:ASN:HD21	1:C:20:ALA:HB3	1.71	0.55

Continued on next page...

Continued from previous page...

Atom-1	Atom-2	Interatomic distance (Å)	Clash overlap (Å)
1:A:293:LEU:HD13	1:A:297:ASN:HB2	1.88	0.54
1:A:41:VAL:HG12	1:A:45:LEU:CD1	2.36	0.54
1:C:10:PHE:CE1	1:C:79:LEU:HD11	2.43	0.54
1:F:92:THR:HG21	1:F:104:ALA:HB1	1.89	0.54
1:C:16:ASN:ND2	1:C:20:ALA:HB3	2.22	0.54
1:C:92:THR:C	1:C:93:LEU:HD23	2.27	0.54
1:D:182:VAL:HG11	1:D:196:ILE:CG2	2.37	0.54
1:B:201:THR:CG2	4:B:713:HOH:O	2.40	0.54
1:C:44:ILE:CD1	1:C:64:LEU:HD23	2.37	0.54
1:C:189:ARG:HD2	1:C:204:HIS:O	2.07	0.54
1:E:115:HIS:NE2	1:E:177:VAL:CG1	2.71	0.54
1:C:14:THR:HG21	4:C:582:HOH:O	2.07	0.54
1:E:26:TYR:OH	1:E:92:THR:HG21	2.06	0.54
1:E:14:THR:CG2	1:E:23:GLU:OE2	2.55	0.53
1:C:8:LEU:HD23	1:C:33:PRO:HG3	1.90	0.53
1:C:45:LEU:HB3	1:C:54:LEU:HD13	1.90	0.53
1:F:45:LEU:HG	1:F:64:LEU:HD21	1.91	0.53
1:B:92:THR:OG1	1:B:108:LEU:HD22	2.09	0.53
1:C:41:VAL:HG13	1:C:64:LEU:CD2	2.39	0.53
1:F:47:TYR:HB2	1:F:93:LEU:HD12	1.90	0.53
1:B:236:LEU:HG	1:B:262:ILE:HD12	1.91	0.53
1:C:24:VAL:HG11	1:C:90:VAL:CG1	2.39	0.53
1:E:201:THR:HG23	1:E:219:MET:HA	1.90	0.53
1:F:47:TYR:CB	1:F:93:LEU:HD12	2.38	0.52
1:A:41:VAL:HG13	1:A:64:LEU:CD2	2.39	0.52
1:D:84:GLU:HB2	4:D:717:HOH:O	2.08	0.52
1:A:302:VAL:HG11	1:C:321:GLN:HE21	1.73	0.52
1:F:225:SER:HB3	1:F:244:GLY:HA2	1.90	0.52
1:C:14:THR:CG2	1:C:23:GLU:OE1	2.53	0.52
1:C:62:TYR:CZ	1:C:83:ALA:HB1	2.45	0.52
1:E:59:GLN:NE2	4:E:949:HOH:O	2.43	0.52
1:E:290:VAL:HG11	1:E:327:CYS:HB2	1.91	0.52
1:C:21:TRP:HZ2	1:C:55:THR:HG22	1.75	0.52
1:D:8:LEU:HD13	1:D:93:LEU:CD2	2.40	0.51
1:C:45:LEU:CD2	1:C:91:ALA:HB3	2.40	0.51
1:B:92:THR:C	1:B:93:LEU:HD23	2.31	0.51
1:C:22:LEU:HD22	1:C:135:VAL:CG2	2.35	0.51
1:D:15:GLN:HE21	1:D:88:PRO:HG3	1.75	0.51
1:D:174:THR:HG22	1:D:178:VAL:HG22	1.92	0.51
1:D:267:GLY:HA3	1:D:283:TYR:CE2	2.46	0.51
1:D:267:GLY:HA3	1:D:283:TYR:CD2	2.46	0.50

Continued on next page...

Continued from previous page...

Atom-1	Atom-2	Interatomic distance (Å)	Clash overlap (Å)
1:A:282:LEU:HD23	1:A:283:TYR:N	2.27	0.50
1:B:57:THR:H	1:B:60:GLN:HE21	1.59	0.50
1:E:21:TRP:CZ2	1:E:90:VAL:HG13	2.46	0.50
1:C:277:ILE:HB	1:C:315:LEU:HD12	1.93	0.50
1:C:64:LEU:HB3	1:C:79:LEU:HD13	1.93	0.50
1:A:41:VAL:CG1	1:A:45:LEU:CD1	2.90	0.49
1:A:139:ASN:ND2	1:A:163:GLU:H	2.10	0.49
1:B:271:PRO:HD2	1:B:309:ALA:HB1	1.94	0.49
1:B:292:LEU:HD12	1:B:293:LEU:H	1.77	0.49
1:C:44:ILE:HD12	1:C:64:LEU:HD23	1.94	0.49
1:B:177:VAL:HG12	4:B:371:HOH:O	2.13	0.49
1:B:182:VAL:HG22	1:B:196:ILE:HG22	1.95	0.49
1:E:259:GLY:O	1:E:275:ARG:HA	2.13	0.49
1:C:45:LEU:HD21	1:C:91:ALA:CB	2.43	0.49
1:F:57:THR:OG1	1:F:58:SER:N	2.46	0.48
1:C:191:ARG:HH12	2:C:351:P0A:HAH	1.78	0.48
1:C:138:THR:HG22	1:C:164:VAL:HG22	1.96	0.48
1:D:154:GLU:HA	1:D:157:LEU:HD12	1.95	0.48
1:E:78:LEU:O	1:E:82:LEU:HD22	2.13	0.48
1:E:201:THR:HG22	4:E:587:HOH:O	2.13	0.48
1:C:82:LEU:HD22	1:C:89:LEU:HD22	1.95	0.48
1:D:290:VAL:HG11	1:D:327:CYS:HB2	1.96	0.48
1:F:16:ASN:OD1	1:F:19:GLU:N	2.46	0.48
1:C:45:LEU:HD21	1:C:91:ALA:HB3	1.95	0.48
1:C:252:ILE:O	1:C:252:ILE:HD12	2.13	0.48
1:F:16:ASN:OD1	1:F:16:ASN:C	2.51	0.48
1:A:203:MET:SD	2:A:345:P0A:HAHA	2.54	0.48
1:A:282:LEU:HD22	1:A:284:ILE:HG23	1.95	0.48
1:B:282:LEU:HD12	1:B:317:ARG:HA	1.96	0.48
1:E:14:THR:HG23	1:E:23:GLU:HG3	1.95	0.48
1:C:103:THR:OG1	1:C:131:LEU:O	2.20	0.48
1:E:214:THR:HG22	1:E:230:VAL:HB	1.95	0.48
1:B:282:LEU:HD21	1:B:284:ILE:HG23	1.94	0.47
1:C:77:ALA:O	1:C:81:ARG:HG2	2.13	0.47
1:F:57:THR:HG23	1:F:60:GLN:H	1.79	0.47
1:A:41:VAL:HG13	1:A:64:LEU:HD21	1.96	0.47
1:F:322:ASN:OD1	1:F:324:ALA:HB2	2.13	0.47
1:C:107:TYR:CE1	1:C:132:LEU:HD22	2.48	0.47
1:E:182:VAL:HG11	1:E:196:ILE:HG21	1.96	0.47
1:D:139:ASN:ND2	1:D:163:GLU:H	2.12	0.47
1:C:34:SER:O	1:C:38:VAL:HG23	2.15	0.47

Continued on next page...

Continued from previous page...

Atom-1	Atom-2	Interatomic distance (Å)	Clash overlap (Å)
1:C:57:THR:HG23	1:C:60:GLN:HE21	1.78	0.47
1:E:8:LEU:HD12	1:E:8:LEU:C	2.34	0.47
1:C:174:THR:HG21	1:C:187:THR:CG2	2.44	0.47
1:E:59:GLN:NE2	4:E:601:HOH:O	2.47	0.47
1:E:308:LEU:HD13	1:E:327:CYS:SG	2.55	0.47
1:F:8:LEU:HD21	1:F:37:ILE:HG22	1.97	0.47
1:E:252:ILE:HD12	1:E:252:ILE:O	2.15	0.47
1:B:41:VAL:HG22	1:B:64:LEU:CD2	2.35	0.46
1:F:8:LEU:C	1:F:8:LEU:HD12	2.35	0.46
1:F:290:VAL:HG11	1:F:327:CYS:HB2	1.97	0.46
1:E:26:TYR:OH	1:E:92:THR:CG2	2.64	0.46
1:E:78:LEU:O	1:E:82:LEU:CD2	2.64	0.46
1:E:174:THR:OG1	1:E:187:THR:HB	2.15	0.46
1:A:261:LEU:HD23	1:A:262:ILE:N	2.31	0.46
1:E:201:THR:HG21	1:E:219:MET:HE2	1.97	0.46
1:B:115:HIS:CE1	1:B:177:VAL:CG1	2.99	0.46
1:F:272:LEU:HD22	1:F:276:ASN:HD22	1.80	0.46
1:A:302:VAL:HG11	1:C:321:GLN:NE2	2.30	0.46
1:B:109:LYS:HE2	1:B:123:VAL:CG2	2.46	0.46
1:B:261:LEU:HD23	1:B:262:ILE:N	2.31	0.46
1:C:82:LEU:HD22	1:C:89:LEU:CD2	2.46	0.46
2:D:351:P0A:HAG	1:F:203:MET:HE2	1.97	0.46
1:D:5:LEU:HD22	1:D:95:ALA:HA	1.98	0.46
1:F:21:TRP:O	1:F:103:THR:HG21	2.16	0.46
1:B:128:ILE:HG12	1:B:132:LEU:CD1	2.46	0.45
2:E:351:P0A:HAG	2:E:351:P0A:OAB	2.16	0.45
1:F:8:LEU:HD21	1:F:37:ILE:CG2	2.47	0.45
1:E:57:THR:H	1:E:60:GLN:NE2	2.12	0.45
1:F:93:LEU:O	1:F:94:LEU:HD23	2.16	0.45
1:A:64:LEU:HB3	1:A:79:LEU:HD13	1.98	0.45
1:B:282:LEU:HD23	1:B:283:TYR:N	2.31	0.45
1:C:41:VAL:HG13	1:C:64:LEU:HD21	1.98	0.45
1:F:185:ALA:HB1	1:F:204:HIS:CE1	2.51	0.45
1:D:166:SER:HA	1:F:187:THR:HG23	1.99	0.45
1:D:293:LEU:HD22	1:D:299:LEU:HA	1.97	0.45
1:F:6:PHE:O	1:F:31:LEU:HD12	2.17	0.45
1:B:57:THR:H	1:B:60:GLN:NE2	2.15	0.44
1:C:65:ALA:O	1:C:76:SER:OG	2.35	0.44
1:F:14:THR:HG23	1:F:23:GLU:HG3	1.99	0.44
1:E:41:VAL:HG12	1:E:45:LEU:HD12	2.00	0.44
1:C:282:LEU:HD22	1:C:284:ILE:CG2	2.48	0.44

Continued on next page...

Continued from previous page...

Atom-1	Atom-2	Interatomic distance (Å)	Clash overlap (Å)
1:E:219:MET:O	1:E:220:ILE:HD13	2.17	0.44
1:C:282:LEU:HD22	1:C:284:ILE:HG23	1.98	0.44
1:B:183:ARG:HB2	1:B:201:THR:HA	1.99	0.44
1:F:92:THR:CG2	1:F:104:ALA:HB1	2.47	0.44
1:F:122:ALA:HB2	4:F:395:HOH:O	2.18	0.44
1:F:3:GLN:NE2	1:F:4:SER:O	2.51	0.44
1:B:42:ALA:HB3	1:B:43:PRO:HD3	2.00	0.43
3:E:345:GOL:H12	1:F:139:ASN:HB2	1.97	0.43
1:B:282:LEU:HD23	1:B:282:LEU:C	2.38	0.43
1:E:133:PRO:O	1:E:135:VAL:HG23	2.18	0.43
1:F:230:VAL:HG12	1:F:234:SER:HB2	1.99	0.43
1:C:319:ASN:HD22	1:C:322:ASN:H	1.66	0.43
1:C:311:GLN:HB2	1:C:314:LEU:HD11	2.00	0.43
1:D:261:LEU:C	1:D:261:LEU:HD13	2.39	0.43
1:F:8:LEU:HB2	1:F:93:LEU:CD2	2.47	0.43
1:D:268:ILE:HG13	1:D:268:ILE:O	2.19	0.43
1:E:14:THR:HG21	4:E:350:HOH:O	2.18	0.43
1:E:201:THR:HG23	1:E:219:MET:SD	2.58	0.43
1:F:58:SER:OG	1:F:83:ALA:O	2.29	0.43
1:E:8:LEU:HD12	1:E:9:ALA:N	2.33	0.43
1:E:41:VAL:HG12	1:E:45:LEU:CD1	2.49	0.43
1:E:277:ILE:O	1:E:315:LEU:HD12	2.19	0.43
1:A:102:SER:CA	1:A:131:LEU:HD22	2.49	0.43
1:D:282:LEU:HD22	1:D:284:ILE:HG23	2.01	0.43
1:E:154:GLU:HA	1:E:157:LEU:HD12	2.01	0.43
1:B:282:LEU:CD2	1:B:282:LEU:C	2.87	0.42
1:D:153:LEU:HG	1:F:27:ALA:HB2	2.00	0.42
1:E:261:LEU:HD12	1:E:277:ILE:HG23	2.01	0.42
1:A:27:ALA:O	1:A:28:LEU:HD23	2.20	0.42
1:D:311:GLN:HB2	1:D:314:LEU:CD1	2.44	0.42
1:B:268:ILE:HG21	1:B:272:LEU:CD1	2.36	0.42
1:C:44:ILE:HD13	1:C:64:LEU:HD23	2.01	0.42
1:D:47:TYR:OH	1:D:95:ALA:HB2	2.20	0.42
1:F:82:LEU:O	1:F:89:LEU:HD11	2.20	0.42
1:C:26:TYR:HB2	1:C:111:HIS:CD2	2.55	0.42
1:F:56:PHE:CE2	1:F:91:ALA:HB2	2.55	0.42
1:F:93:LEU:C	1:F:94:LEU:HD23	2.40	0.42
1:A:27:ALA:HB2	1:B:153:LEU:HD13	2.02	0.42
1:C:41:VAL:HG13	1:C:64:LEU:HD22	2.01	0.42
1:D:8:LEU:HD13	1:D:93:LEU:HD22	2.00	0.42
1:D:185:ALA:HB1	1:D:204:HIS:CE1	2.55	0.42

Continued on next page...

Continued from previous page...

Atom-1	Atom-2	Interatomic distance (Å)	Clash overlap (Å)
1:E:187:THR:HG23	1:F:166:SER:HA	2.01	0.42
1:C:16:ASN:OD1	1:C:20:ALA:HB3	2.19	0.42
1:D:183:ARG:HD2	1:E:168:ASP:OD1	2.20	0.42
1:F:179:PRO:O	1:F:182:VAL:HG22	2.20	0.42
1:C:8:LEU:HD23	1:C:33:PRO:CG	2.48	0.42
1:F:56:PHE:HB2	1:F:60:GLN:HB2	2.01	0.42
1:A:42:ALA:HB3	1:A:43:PRO:HD3	2.01	0.41
1:B:16:ASN:HB3	1:B:22:LEU:HD21	2.02	0.41
1:C:90:VAL:HG22	1:C:92:THR:CG2	2.50	0.41
1:F:53:ALA:CB	1:F:104:ALA:HB3	2.50	0.41
1:A:153:LEU:HD22	1:A:157:LEU:CD1	2.51	0.41
1:B:8:LEU:C	1:B:8:LEU:HD12	2.40	0.41
2:A:345:P0A:HA	1:B:209:ASN:ND2	2.34	0.41
1:E:108:LEU:O	1:E:108:LEU:HD12	2.20	0.41
1:F:128:ILE:HG22	4:F:460:HOH:O	2.20	0.41
1:A:189:ARG:HD3	1:A:206:GLY:O	2.20	0.41
1:F:116:ARG:NH2	1:F:179:PRO:HB2	2.35	0.41
1:A:139:ASN:CB	3:A:346:GOL:H12	2.49	0.41
1:A:268:ILE:HG21	1:A:272:LEU:CD1	2.51	0.41
1:A:282:LEU:HD12	1:A:317:ARG:HA	2.03	0.41
1:E:201:THR:CG2	1:E:219:MET:HA	2.49	0.41
2:A:351:P0A:HAH	1:C:203:MET:SD	2.61	0.41
1:B:81:ARG:HB3	1:C:157:LEU:HD11	2.03	0.41
1:C:12:VAL:O	1:C:12:VAL:HG13	2.20	0.41
1:D:115:HIS:HD2	4:D:939:HOH:O	2.04	0.41
1:C:9:ALA:HB1	1:C:26:TYR:CD2	2.57	0.40
1:D:92:THR:C	1:D:93:LEU:HD23	2.41	0.40
1:A:145:LEU:HD23	1:A:145:LEU:HA	1.94	0.40
1:E:69:LYS:NZ	4:E:1010:HOH:O	2.54	0.40
1:C:17:ARG:NH2	4:C:784:HOH:O	2.54	0.40
1:F:82:LEU:HB3	1:F:89:LEU:HD13	2.03	0.40
1:F:129:PHE:O	1:F:169:LYS:NZ	2.38	0.40
1:B:176:TYR:C	1:B:177:VAL:CG1	2.90	0.40
1:D:156:ARG:HG3	1:F:25:PHE:CD2	2.56	0.40

There are no symmetry-related clashes.

5.3 Torsion angles [i](#)

5.3.1 Protein backbone [i](#)

In the following table, the Percentiles column shows the percent Ramachandran outliers of the chain as a percentile score with respect to all X-ray entries followed by that with respect to entries of similar resolution.

The Analysed column shows the number of residues for which the backbone conformation was analysed, and the total number of residues.

Mol	Chain	Analysed	Favoured	Allowed	Outliers	Percentiles	
1	A	315/347 (91%)	302 (96%)	13 (4%)	0	100	100
1	B	312/347 (90%)	302 (97%)	10 (3%)	0	100	100
1	C	317/347 (91%)	306 (96%)	11 (4%)	0	100	100
1	D	315/347 (91%)	307 (98%)	8 (2%)	0	100	100
1	E	303/347 (87%)	299 (99%)	4 (1%)	0	100	100
1	F	317/347 (91%)	303 (96%)	14 (4%)	0	100	100
All	All	1879/2082 (90%)	1819 (97%)	60 (3%)	0	100	100

There are no Ramachandran outliers to report.

5.3.2 Protein sidechains [i](#)

In the following table, the Percentiles column shows the percent sidechain outliers of the chain as a percentile score with respect to all X-ray entries followed by that with respect to entries of similar resolution.

The Analysed column shows the number of residues for which the sidechain conformation was analysed, and the total number of residues.

Mol	Chain	Analysed	Rotameric	Outliers	Percentiles	
1	A	244/263 (93%)	237 (97%)	7 (3%)	42	35
1	B	241/263 (92%)	226 (94%)	15 (6%)	18	9
1	C	244/263 (93%)	231 (95%)	13 (5%)	22	13
1	D	244/263 (93%)	229 (94%)	15 (6%)	18	9
1	E	236/263 (90%)	223 (94%)	13 (6%)	21	12
1	F	244/263 (93%)	231 (95%)	13 (5%)	22	13
All	All	1453/1578 (92%)	1377 (95%)	76 (5%)	23	14

All (76) residues with a non-rotameric sidechain are listed below:

Mol	Chain	Res	Type
1	A	153	LEU
1	A	243	MET
1	A	251	ASN
1	A	283	TYR
1	A	306	ARG
1	A	317	ARG
1	A	319	ASN
1	B	5	LEU
1	B	12	VAL
1	B	41	VAL
1	B	82	LEU
1	B	177	VAL
1	B	201	THR
1	B	243	MET
1	B	251	ASN
1	B	252	ILE
1	B	271	PRO
1	B	297	ASN
1	B	306	ARG
1	B	315	LEU
1	B	317	ARG
1	B	319	ASN
1	C	3	GLN
1	C	8	LEU
1	C	14	THR
1	C	35	SER
1	C	59	GLN
1	C	66	ASP
1	C	93	LEU
1	C	153	LEU
1	C	189	ARG
1	C	235	ASP
1	C	261	LEU
1	C	317	ARG
1	C	329	THR
1	D	4	SER
1	D	8	LEU
1	D	18	GLN
1	D	35	SER
1	D	72	ASP
1	D	93	LEU
1	D	150	GLU

Continued on next page...

Continued from previous page...

Mol	Chain	Res	Type
1	D	153	LEU
1	D	243	MET
1	D	261	LEU
1	D	265	ASN
1	D	282	LEU
1	D	284	ILE
1	D	306	ARG
1	D	319	ASN
1	E	8	LEU
1	E	14	THR
1	E	66	ASP
1	E	69	LYS
1	E	92	THR
1	E	150	GLU
1	E	177	VAL
1	E	195	TYR
1	E	198	GLU
1	E	243	MET
1	E	282	LEU
1	E	306	ARG
1	E	329	THR
1	F	8	LEU
1	F	14	THR
1	F	35	SER
1	F	59	GLN
1	F	92	THR
1	F	96	GLU
1	F	134	ASN
1	F	153	LEU
1	F	282	LEU
1	F	283	TYR
1	F	306	ARG
1	F	319	ASN
1	F	322	ASN

Sometimes sidechains can be flipped to improve hydrogen bonding and reduce clashes. All (47) such sidechains are listed below:

Mol	Chain	Res	Type
1	A	15	GLN
1	A	52	GLN
1	A	59	GLN
1	A	60	GLN

Continued on next page...

Continued from previous page...

Mol	Chain	Res	Type
1	A	63	GLN
1	A	115	HIS
1	A	134	ASN
1	A	139	ASN
1	A	251	ASN
1	A	276	ASN
1	A	319	ASN
1	B	18	GLN
1	B	52	GLN
1	B	60	GLN
1	B	115	HIS
1	B	134	ASN
1	B	276	ASN
1	B	319	ASN
1	C	52	GLN
1	C	59	GLN
1	C	60	GLN
1	C	121	HIS
1	C	276	ASN
1	C	319	ASN
1	C	321	GLN
1	D	15	GLN
1	D	52	GLN
1	D	59	GLN
1	D	60	GLN
1	D	86	GLN
1	D	115	HIS
1	D	134	ASN
1	D	139	ASN
1	D	319	ASN
1	E	3	GLN
1	E	15	GLN
1	E	18	GLN
1	E	52	GLN
1	E	59	GLN
1	E	60	GLN
1	E	134	ASN
1	F	18	GLN
1	F	60	GLN
1	F	115	HIS
1	F	134	ASN
1	F	276	ASN

Continued on next page...

Continued from previous page...

Mol	Chain	Res	Type
1	F	319	ASN

5.3.3 RNA [i](#)

There are no RNA molecules in this entry.

5.4 Non-standard residues in protein, DNA, RNA chains [i](#)

There are no non-standard protein/DNA/RNA residues in this entry.

5.5 Carbohydrates [i](#)

There are no monosaccharides in this entry.

5.6 Ligand geometry [i](#)

8 ligands are modelled in this entry.

In the following table, the Counts columns list the number of bonds (or angles) for which Mogul statistics could be retrieved, the number of bonds (or angles) that are observed in the model and the number of bonds (or angles) that are defined in the Chemical Component Dictionary. The Link column lists molecule types, if any, to which the group is linked. The Z score for a bond length (or angle) is the number of standard deviations the observed value is removed from the expected value. A bond length (or angle) with $|Z| > 2$ is considered an outlier worth inspection. RMSZ is the root-mean-square of all Z scores of the bond lengths (or angles).

Mol	Type	Chain	Res	Link	Bond lengths			Bond angles		
					Counts	RMSZ	$\# Z > 2$	Counts	RMSZ	$\# Z > 2$
2	P0A	D	351	-	10,11,11	1.05	0	12,13,13	0.94	0
2	P0A	F	351	-	10,11,11	1.04	0	12,13,13	0.98	0
2	P0A	E	351	-	10,11,11	1.05	0	12,13,13	0.89	1 (8%)
3	GOL	A	346	-	5,5,5	0.33	0	5,5,5	1.62	1 (20%)
3	GOL	E	345	-	5,5,5	0.38	0	5,5,5	1.02	0
2	P0A	C	351	-	10,11,11	0.98	0	12,13,13	0.99	0
2	P0A	A	345	-	10,11,11	1.06	0	12,13,13	1.02	1 (8%)
2	P0A	A	351	-	10,11,11	1.11	0	12,13,13	0.84	0

In the following table, the Chirals column lists the number of chiral outliers, the number of chiral centers analysed, the number of these observed in the model and the number defined in the Chemical Component Dictionary. Similar counts are reported in the Torsion and Rings columns.

'-' means no outliers of that kind were identified.

Mol	Type	Chain	Res	Link	Chirals	Torsions	Rings
2	P0A	D	351	-	-	2/11/11/11	-
2	P0A	F	351	-	-	3/11/11/11	-
2	P0A	E	351	-	-	5/11/11/11	-
3	GOL	A	346	-	-	1/4/4/4	-
3	GOL	E	345	-	-	1/4/4/4	-
2	P0A	C	351	-	-	4/11/11/11	-
2	P0A	A	345	-	-	6/11/11/11	-
2	P0A	A	351	-	-	6/11/11/11	-

There are no bond length outliers.

All (3) bond angle outliers are listed below:

Mol	Chain	Res	Type	Atoms	Z	Observed(°)	Ideal(°)
3	A	346	GOL	O2-C2-C1	2.55	120.35	109.12
2	A	345	P0A	OAB-CAJ-CAH	-2.23	115.91	123.08
2	E	351	P0A	OAB-CAJ-CAH	-2.12	116.27	123.08

There are no chirality outliers.

All (28) torsion outliers are listed below:

Mol	Chain	Res	Type	Atoms
2	A	351	P0A	O-C-CA-N
2	A	345	P0A	O-C-CA-N
2	A	351	P0A	CAG-CAF-CAH-CAJ
2	A	345	P0A	OXT-C-CA-N
2	E	351	P0A	CAH-CAF-CAG-CB
2	A	345	P0A	CAH-CAF-CAG-CB
2	C	351	P0A	CAH-CAF-CAG-CB
2	E	351	P0A	CAF-CAG-CB-CA
2	A	345	P0A	CAF-CAG-CB-CA
2	D	351	P0A	CAH-CAF-CAG-CB
3	A	346	GOL	O2-C2-C3-O3
2	F	351	P0A	C-CA-CB-CAG
2	A	351	P0A	OXT-C-CA-N
2	D	351	P0A	CAG-CAF-CAH-CAJ
2	A	351	P0A	CAH-CAF-CAG-CB
2	A	345	P0A	O-C-CA-CB
2	A	345	P0A	OXT-C-CA-CB
2	E	351	P0A	CAG-CAF-CAH-CAJ

Continued on next page...

Continued from previous page...

Mol	Chain	Res	Type	Atoms
2	C	351	P0A	CAG-CAF-CAH-CAJ
2	E	351	P0A	CAF-CAH-CAJ-OAB
2	C	351	P0A	CAF-CAH-CAJ-OAB
2	E	351	P0A	CAF-CAH-CAJ-OAD
2	C	351	P0A	CAF-CAH-CAJ-OAD
2	A	351	P0A	CAF-CAH-CAJ-OAB
2	F	351	P0A	CAF-CAH-CAJ-OAB
3	E	345	GOL	O1-C1-C2-O2
2	A	351	P0A	CAF-CAH-CAJ-OAD
2	F	351	P0A	CAF-CAH-CAJ-OAD

There are no ring outliers.

7 monomers are involved in 14 short contacts:

Mol	Chain	Res	Type	Clashes	Symm-Clashes
2	D	351	P0A	1	0
2	E	351	P0A	2	0
3	A	346	GOL	2	0
3	E	345	GOL	5	0
2	C	351	P0A	1	0
2	A	345	P0A	2	0
2	A	351	P0A	1	0

5.7 Other polymers [i](#)

There are no such residues in this entry.

5.8 Polymer linkage issues [i](#)

There are no chain breaks in this entry.

6 Fit of model and data

6.1 Protein, DNA and RNA chains

In the following table, the column labelled ‘#RSRZ> 2’ contains the number (and percentage) of RSRZ outliers, followed by percent RSRZ outliers for the chain as percentile scores relative to all X-ray entries and entries of similar resolution. The OWAB column contains the minimum, median, 95th percentile and maximum values of the occupancy-weighted average B-factor per residue. The column labelled ‘Q< 0.9’ lists the number of (and percentage) of residues with an average occupancy less than 0.9.

Mol	Chain	Analysed	<RSRZ>	#RSRZ>2	OWAB(Å ²)	Q<0.9
1	A	321/347 (92%)	0.58	32 (9%) 7 8	17, 28, 51, 57	0
1	B	318/347 (91%)	0.61	39 (12%) 4 4	17, 27, 51, 57	0
1	C	321/347 (92%)	0.59	36 (11%) 5 6	18, 28, 51, 57	0
1	D	321/347 (92%)	0.58	37 (11%) 4 5	17, 27, 51, 56	0
1	E	311/347 (89%)	0.61	35 (11%) 5 5	17, 26, 50, 56	0
1	F	321/347 (92%)	0.58	34 (10%) 6 7	18, 28, 50, 56	0
All	All	1913/2082 (91%)	0.59	213 (11%) 5 6	17, 27, 51, 57	0

All (213) RSRZ outliers are listed below:

Mol	Chain	Res	Type	RSRZ
1	C	252	ILE	7.7
1	E	252	ILE	7.6
1	B	298	ALA	7.2
1	E	297	ASN	6.5
1	B	252	ILE	6.4
1	E	299	LEU	6.4
1	D	252	ILE	5.6
1	F	252	ILE	5.5
1	F	70	GLY	5.1
1	B	251	ASN	5.0
1	C	253	VAL	4.9
1	E	324	ALA	4.7
1	A	251	ASN	4.7
1	E	325	VAL	4.7
1	C	3	GLN	4.7
1	B	297	ASN	4.6
1	A	300	VAL	4.6
1	D	299	LEU	4.6
1	E	251	ASN	4.5

Continued on next page...

Continued from previous page...

Mol	Chain	Res	Type	RSRZ
1	E	302	VAL	4.5
1	E	305	ALA	4.5
1	A	302	VAL	4.4
1	A	252	ILE	4.3
1	E	300	VAL	4.3
1	D	300	VAL	4.3
1	C	296	GLN	4.2
1	C	251	ASN	4.2
1	D	283	TYR	4.2
1	A	297	ASN	4.1
1	E	298	ALA	4.1
1	B	299	LEU	4.0
1	D	302	VAL	4.0
1	B	283	TYR	4.0
1	C	297	ASN	4.0
1	F	322	ASN	3.9
1	A	69	LYS	3.9
1	A	321	GLN	3.9
1	D	321	GLN	3.9
1	D	251	ASN	3.8
1	D	323	GLY	3.7
1	A	283	TYR	3.7
1	E	283	TYR	3.7
1	E	293	LEU	3.7
1	F	251	ASN	3.7
1	F	3	GLN	3.7
1	C	19	GLU	3.7
1	B	285	THR	3.6
1	D	322	ASN	3.6
1	B	293	LEU	3.6
1	D	253	VAL	3.6
1	C	283	TYR	3.5
1	E	294	ASP	3.5
1	B	300	VAL	3.5
1	E	3	GLN	3.5
1	D	297	ASN	3.5
1	F	297	ASN	3.5
1	B	253	VAL	3.3
1	F	66	ASP	3.3
1	D	245	THR	3.3
1	C	66	ASP	3.3
1	F	296	GLN	3.3

Continued on next page...

Continued from previous page...

Mol	Chain	Res	Type	RSRZ
1	B	291	ALA	3.2
1	C	48	ALA	3.2
1	B	10	PHE	3.2
1	E	10	PHE	3.2
1	C	298	ALA	3.2
1	D	298	ALA	3.2
1	F	4	SER	3.2
1	C	70	GLY	3.1
1	F	295	GLU	3.1
1	C	40	ALA	3.1
1	A	245	THR	3.1
1	B	294	ASP	3.1
1	F	48	ALA	3.1
1	A	318	ARG	3.1
1	A	320	SER	3.1
1	A	3	GLN	3.1
1	F	321	GLN	3.1
1	C	321	GLN	3.0
1	F	283	TYR	3.0
1	B	86	GLN	3.0
1	C	316	PHE	3.0
1	F	262	ILE	3.0
1	B	311	GLN	3.0
1	D	3	GLN	3.0
1	F	272	LEU	3.0
1	C	295	GLU	3.0
1	B	301	LYS	3.0
1	D	224	VAL	3.0
1	D	290	VAL	3.0
1	A	290	VAL	2.9
1	B	3	GLN	2.9
1	A	323	GLY	2.9
1	B	309	ALA	2.9
1	C	294	ASP	2.9
1	C	4	SER	2.9
1	A	253	VAL	2.9
1	F	316	PHE	2.9
1	D	9	ALA	2.8
1	F	244	GLY	2.8
1	D	66	ASP	2.8
1	F	208	VAL	2.8
1	E	309	ALA	2.7

Continued on next page...

Continued from previous page...

Mol	Chain	Res	Type	RSRZ
1	B	64	LEU	2.7
1	E	79	LEU	2.7
1	B	208	VAL	2.7
1	E	278	VAL	2.7
1	E	64	LEU	2.7
1	A	9	ALA	2.7
1	C	86	GLN	2.7
1	D	244	GLY	2.7
1	A	299	LEU	2.7
1	C	230	VAL	2.6
1	F	256	VAL	2.6
1	A	319	ASN	2.6
1	A	224	VAL	2.6
1	D	4	SER	2.6
1	B	304	LYS	2.6
1	B	316	PHE	2.6
1	E	253	VAL	2.6
1	A	84	GLU	2.6
1	E	279	GLU	2.6
1	E	86	GLN	2.6
1	E	256	VAL	2.6
1	D	230	VAL	2.5
1	F	309	ALA	2.5
1	C	84	GLU	2.5
1	F	230	VAL	2.5
1	A	10	PHE	2.5
1	F	86	GLN	2.5
1	A	298	ALA	2.5
1	B	302	VAL	2.5
1	E	308	LEU	2.5
1	C	62	TYR	2.4
1	D	294	ASP	2.4
1	B	284	ILE	2.4
1	A	4	SER	2.4
1	B	48	ALA	2.4
1	D	142	ALA	2.4
1	F	18	GLN	2.4
1	C	256	VAL	2.4
1	B	280	ALA	2.4
1	F	50	GLY	2.4
1	B	303	VAL	2.4
1	B	325	VAL	2.4

Continued on next page...

Continued from previous page...

Mol	Chain	Res	Type	RSRZ
1	F	320	SER	2.3
1	B	268	ILE	2.3
1	D	256	VAL	2.3
1	F	329	THR	2.3
1	B	306	ARG	2.3
1	D	319	ASN	2.3
1	B	224	VAL	2.3
1	B	315	LEU	2.3
1	E	292	LEU	2.3
1	D	10	PHE	2.3
1	E	306	ARG	2.3
1	F	294	ASP	2.3
1	B	9	ALA	2.3
1	C	9	ALA	2.3
1	E	9	ALA	2.3
1	F	298	ALA	2.3
1	B	4	SER	2.3
1	D	69	LYS	2.3
1	A	256	VAL	2.2
1	E	280	ALA	2.2
1	F	59	GLN	2.2
1	C	57	THR	2.2
1	D	291	ALA	2.2
1	D	307	ASP	2.2
1	D	254	ILE	2.2
1	A	307	ASP	2.2
1	E	285	THR	2.2
1	C	59	GLN	2.2
1	A	230	VAL	2.2
1	F	278	VAL	2.2
1	D	318	ARG	2.2
1	F	77	ALA	2.2
1	A	325	VAL	2.2
1	A	8	LEU	2.2
1	C	18	GLN	2.2
1	F	293	LEU	2.2
1	B	310	GLY	2.2
1	C	43	PRO	2.1
1	C	322	ASN	2.1
1	D	24	VAL	2.1
1	E	303	VAL	2.1
1	F	19	GLU	2.1

Continued on next page...

Continued from previous page...

Mol	Chain	Res	Type	RSRZ
1	B	308	LEU	2.1
1	E	272	LEU	2.1
1	C	49	ALA	2.1
1	D	306	ARG	2.1
1	B	82	LEU	2.1
1	C	304	LYS	2.1
1	A	18	GLN	2.1
1	D	316	PHE	2.1
1	A	303	VAL	2.1
1	E	208	VAL	2.1
1	B	305	ALA	2.1
1	C	73	ALA	2.1
1	A	79	LEU	2.1
1	C	8	LEU	2.1
1	D	17	ARG	2.1
1	D	289	LYS	2.1
1	C	262	ILE	2.1
1	C	272	LEU	2.1
1	E	301	LYS	2.1
1	E	41	VAL	2.0
1	B	92	THR	2.0
1	E	92	THR	2.0
1	D	325	VAL	2.0
1	C	324	ALA	2.0
1	F	95	ALA	2.0
1	A	293	LEU	2.0

6.2 Non-standard residues in protein, DNA, RNA chains [\(i\)](#)

There are no non-standard protein/DNA/RNA residues in this entry.

6.3 Carbohydrates [\(i\)](#)

There are no monosaccharides in this entry.

6.4 Ligands [\(i\)](#)

In the following table, the Atoms column lists the number of modelled atoms in the group and the number defined in the chemical component dictionary. The B-factors column lists the minimum, median, 95th percentile and maximum values of B factors of atoms in the group. The column labelled 'Q< 0.9' lists the number of atoms with occupancy less than 0.9.

Mol	Type	Chain	Res	Atoms	RSCC	RSR	B-factors(\AA^2)	Q<0.9
3	GOL	A	346	6/6	0.73	0.31	18,25,27,27	0
2	P0A	E	351	12/12	0.83	0.19	33,38,38,39	0
2	P0A	A	345	12/12	0.84	0.17	31,36,37,37	0
2	P0A	F	351	12/12	0.89	0.12	42,43,43,43	0
2	P0A	C	351	12/12	0.90	0.13	40,43,44,44	0
2	P0A	D	351	12/12	0.92	0.11	20,27,29,30	0
2	P0A	A	351	12/12	0.92	0.12	20,29,30,30	0
3	GOL	E	345	6/6	0.92	0.35	25,27,28,28	0

6.5 Other polymers [i](#)

There are no such residues in this entry.