



Full wwPDB X-ray Structure Validation Report ⓘ

May 15, 2020 – 08:35 pm BST

PDB ID : 5X6X
Title : Crystal structure of the capping enzyme P5 from Rice Dwarf Virus
Authors : Nakamichi, Y.; Higashiura, A.; Nakagawa, A.
Deposited on : 2017-02-23
Resolution : 2.10 Å(reported)

This is a Full wwPDB X-ray Structure Validation Report for a publicly released PDB entry.

We welcome your comments at validation@mail.wwpdb.org

A user guide is available at

<https://www.wwpdb.org/validation/2017/XrayValidationReportHelp>

with specific help available everywhere you see the ⓘ symbol.

The following versions of software and data (see [references ⓘ](#)) were used in the production of this report:

MolProbity : 4.02b-467
Mogul : 1.8.5 (274361), CSD as541be (2020)
Xtriage (Phenix) : 1.13
EDS : 2.11
Percentile statistics : 20191225.v01 (using entries in the PDB archive December 25th 2019)
Refmac : 5.8.0158
CCP4 : 7.0.044 (Gargrove)
Ideal geometry (proteins) : Engh & Huber (2001)
Ideal geometry (DNA, RNA) : Parkinson et al. (1996)
Validation Pipeline (wwPDB-VP) : 2.11

1 Overall quality at a glance

The following experimental techniques were used to determine the structure:

X-RAY DIFFRACTION

The reported resolution of this entry is 2.10 Å.

Percentile scores (ranging between 0-100) for global validation metrics of the entry are shown in the following graphic. The table shows the number of entries on which the scores are based.

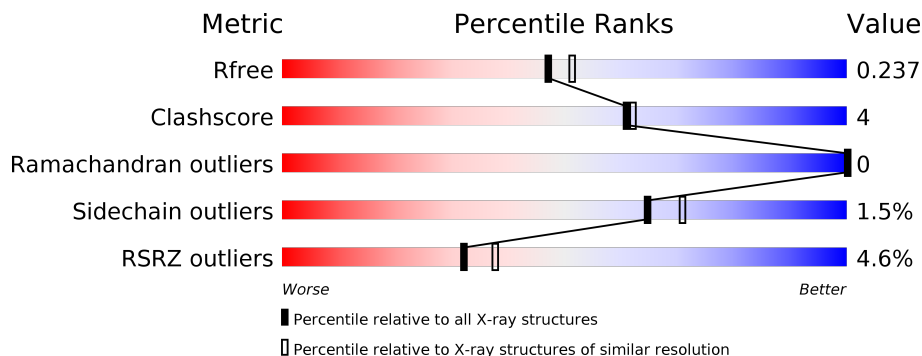

Metric	Whole archive (#Entries)	Similar resolution (#Entries, resolution range(Å))
R_{free}	130704	5197 (2.10-2.10)
Clashscore	141614	5710 (2.10-2.10)
Ramachandran outliers	138981	5647 (2.10-2.10)
Sidechain outliers	138945	5648 (2.10-2.10)
RSRZ outliers	127900	5083 (2.10-2.10)

The table below summarises the geometric issues observed across the polymeric chains and their fit to the electron density. The red, orange, yellow and green segments on the lower bar indicate the fraction of residues that contain outliers for ≥ 3 , 2, 1 and 0 types of geometric quality criteria respectively. A grey segment represents the fraction of residues that are not modelled. The numeric value for each fraction is indicated below the corresponding segment, with a dot representing fractions $\leq 5\%$. The upper red bar (where present) indicates the fraction of residues that have poor fit to the electron density. The numeric value is given above the bar.

Mol	Chain	Length	Quality of chain
1	A	804	
1	B	804	
1	C	804	
1	D	804	

2 Entry composition [i](#)

There are 3 unique types of molecules in this entry. The entry contains 26049 atoms, of which 0 are hydrogens and 0 are deuteriums.

In the tables below, the ZeroOcc column contains the number of atoms modelled with zero occupancy, the AltConf column contains the number of residues with at least one atom in alternate conformation and the Trace column contains the number of residues modelled with at most 2 atoms.

- Molecule 1 is a protein called mRNA capping enzyme P5.

Mol	Chain	Residues	Atoms					ZeroOcc	AltConf	Trace
			Total	C	N	O	S			
1	C	779	Total 6193	C 3990	N 1026	O 1140	S 37	0	0	0
1	A	776	Total 6186	C 3987	N 1029	O 1132	S 38	0	1	0
1	B	778	Total 6185	C 3986	N 1024	O 1138	S 37	0	0	0
1	D	778	Total 6223	C 4010	N 1031	O 1144	S 38	0	4	0

- Molecule 2 is 1,2-ETHANEDIOL (three-letter code: EDO) (formula: C₂H₆O₂).

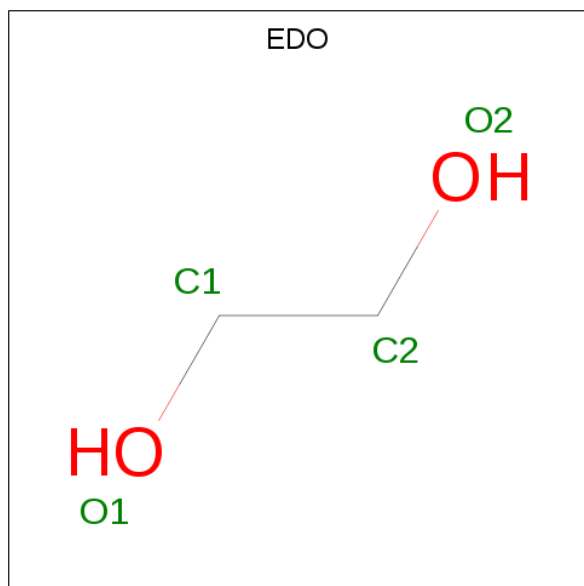

Mol	Chain	Residues	Atoms			ZeroOcc	AltConf
			Total	C	O		
2	C	1	Total 4	C 2	O 2	0	0
2	C	1	Total 4	C 2	O 2	0	0

Continued on next page...

Continued from previous page...

Mol	Chain	Residues	Atoms			ZeroOcc	AltConf
2	A	1	Total	C	O	0	0
			4	2	2		
2	A	1	Total	C	O	0	0
			4	2	2		
2	A	1	Total	C	O	0	0
			4	2	2		
2	D	1	Total	C	O	0	0
			4	2	2		

- Molecule 3 is water.

Mol	Chain	Residues	Atoms		ZeroOcc	AltConf
3	C	312	Total	O	0	0
			312	312		
3	A	349	Total	O	0	0
			349	349		
3	B	270	Total	O	0	0
			270	270		
3	D	307	Total	O	0	0
			307	307		

3 Residue-property plots [i](#)

These plots are drawn for all protein, RNA and DNA chains in the entry. The first graphic for a chain summarises the proportions of the various outlier classes displayed in the second graphic. The second graphic shows the sequence view annotated by issues in geometry and electron density. Residues are color-coded according to the number of geometric quality criteria for which they contain at least one outlier: green = 0, yellow = 1, orange = 2 and red = 3 or more. A red dot above a residue indicates a poor fit to the electron density ($RSRZ > 2$). Stretches of 2 or more consecutive residues without any outlier are shown as a green connector. Residues present in the sample, but not in the model, are shown in grey.

- Molecule 1: mRNA capping enzyme P5

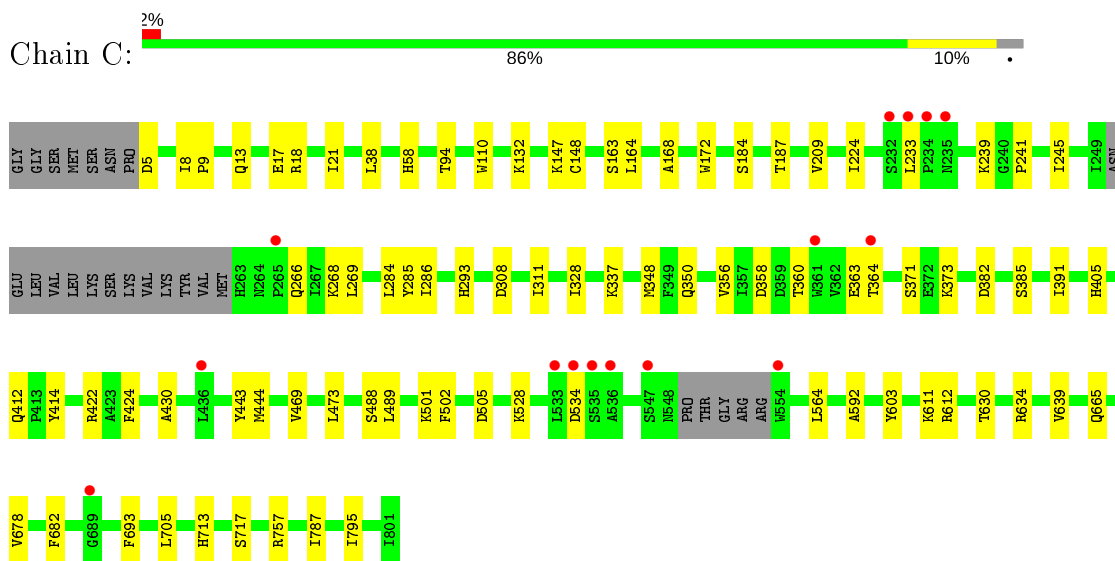

- Molecule 1: mRNA capping enzyme P5

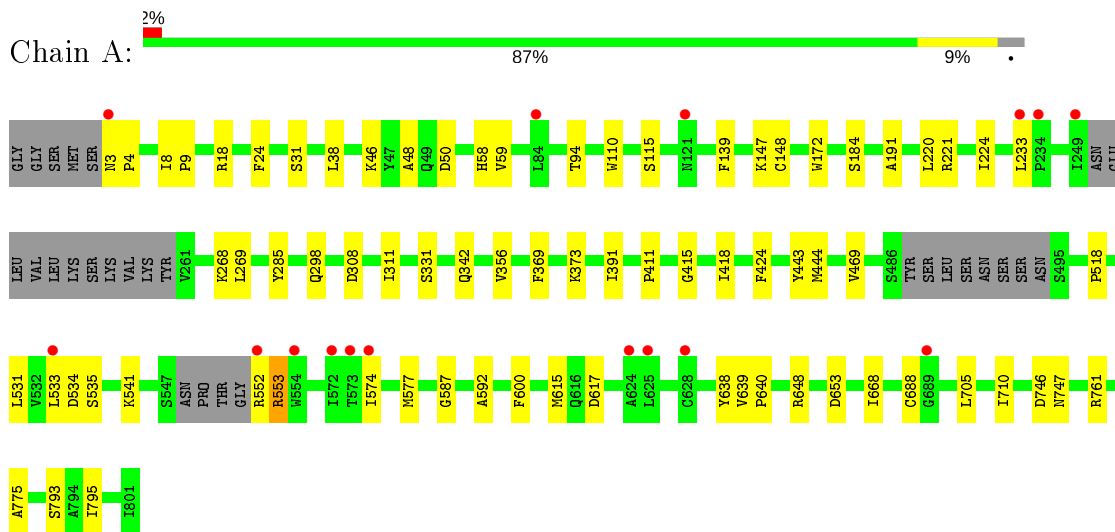

- Molecule 1: mRNA capping enzyme P5

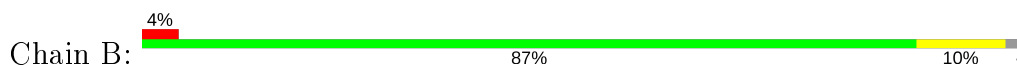

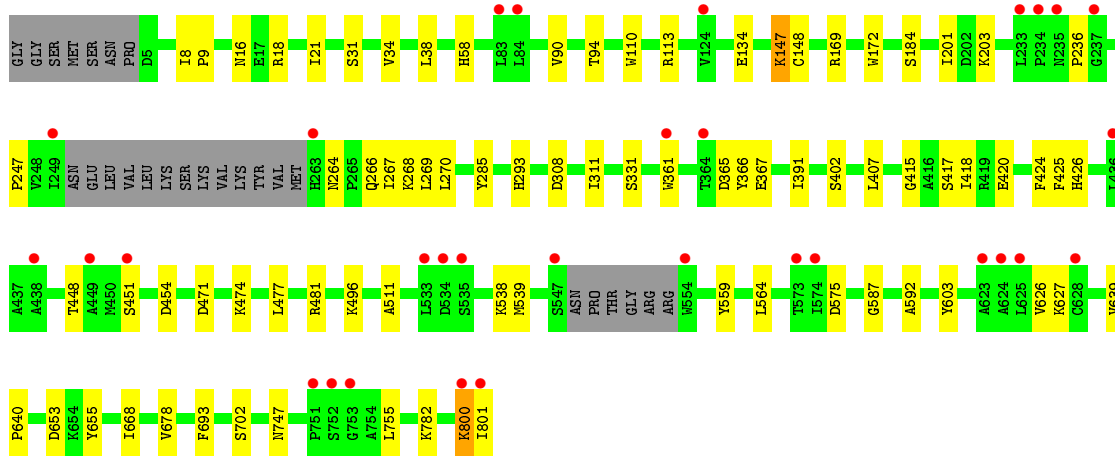

• Molecule 1: mRNA capping enzyme P5

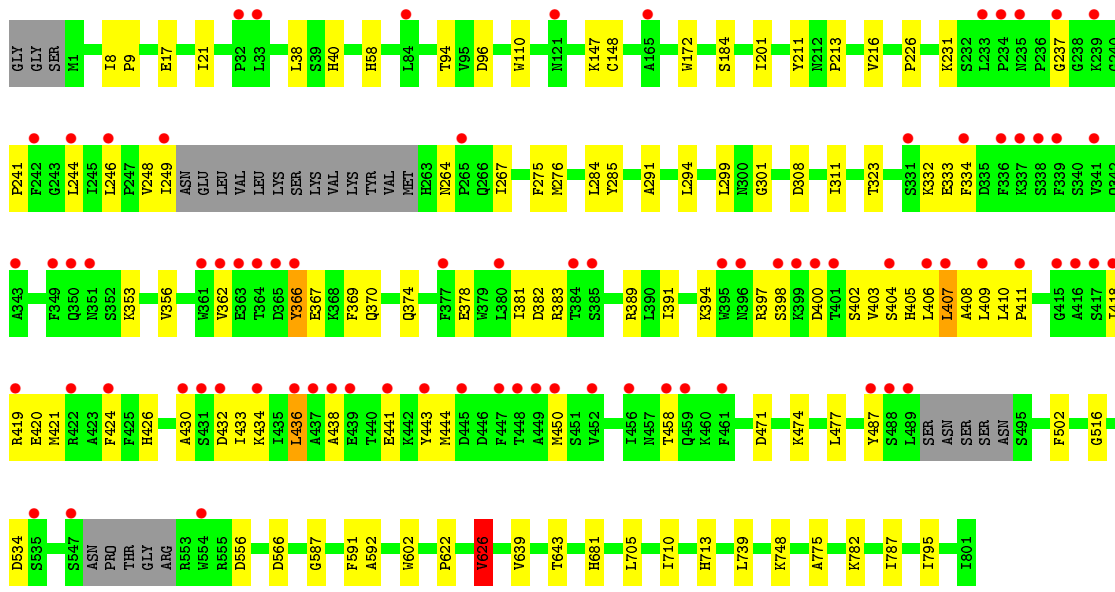
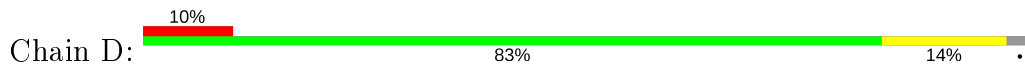

4 Data and refinement statistics

Property	Value	Source
Space group	P 1	Depositor
Cell constants a, b, c, α , β , γ	77.23Å 83.85Å 143.25Å 103.41° 102.47° 95.37°	Depositor
Resolution (Å)	44.50 – 2.10 44.50 – 2.10	Depositor EDS
% Data completeness (in resolution range)	98.5 (44.50-2.10) 98.5 (44.50-2.10)	Depositor EDS
R_{merge}	0.07	Depositor
R_{sym}	(Not available)	Depositor
$\langle I/\sigma(I) \rangle$ ¹	3.21 (at 2.10Å)	Xtrriage
Refinement program	PHENIX (dev_2614: ???)	Depositor
R, R_{free}	0.188 , 0.237 0.188 , 0.237	Depositor DCC
R_{free} test set	9483 reflections (4.89%)	wwPDB-VP
Wilson B-factor (Å ²)	29.3	Xtrriage
Anisotropy	0.186	Xtrriage
Bulk solvent k_{sol} (e/Å ³), B_{sol} (Å ²)	0.34 , 46.4	EDS
L-test for twinning ²	$\langle L \rangle = 0.50$, $\langle L^2 \rangle = 0.33$	Xtrriage
Estimated twinning fraction	0.004 for -h,-k,h+k+l	Xtrriage
F_o, F_c correlation	0.95	EDS
Total number of atoms	26049	wwPDB-VP
Average B, all atoms (Å ²)	37.0	wwPDB-VP

Xtrriage's analysis on translational NCS is as follows: *The largest off-origin peak in the Patterson function is 4.45% of the height of the origin peak. No significant pseudotranslation is detected.*

¹Intensities estimated from amplitudes.

²Theoretical values of $\langle |L| \rangle$, $\langle L^2 \rangle$ for acentric reflections are 0.5, 0.333 respectively for untwinned datasets, and 0.375, 0.2 for perfectly twinned datasets.

5 Model quality [i](#)

5.1 Standard geometry [i](#)

Bond lengths and bond angles in the following residue types are not validated in this section: EDO

The Z score for a bond length (or angle) is the number of standard deviations the observed value is removed from the expected value. A bond length (or angle) with $|Z| > 5$ is considered an outlier worth inspection. RMSZ is the root-mean-square of all Z scores of the bond lengths (or angles).

Mol	Chain	Bond lengths		Bond angles	
		RMSZ	# Z >5	RMSZ	# Z >5
1	A	0.40	0/6335	0.53	0/8594
1	B	0.39	0/6335	0.53	0/8597
1	C	0.42	0/6343	0.54	0/8608
1	D	0.41	0/6373	0.53	1/8645 (0.0%)
All	All	0.40	0/25386	0.53	1/34444 (0.0%)

There are no bond length outliers.

All (1) bond angle outliers are listed below:

Mol	Chain	Res	Type	Atoms	Z	Observed(°)	Ideal(°)
1	D	626	VAL	CB-CA-C	-6.17	99.67	111.40

There are no chirality outliers.

There are no planarity outliers.

5.2 Too-close contacts [i](#)

In the following table, the Non-H and H(model) columns list the number of non-hydrogen atoms and hydrogen atoms in the chain respectively. The H(added) column lists the number of hydrogen atoms added and optimized by MolProbity. The Clashes column lists the number of clashes within the asymmetric unit, whereas Symm-Clashes lists symmetry related clashes.

Mol	Chain	Non-H	H(model)	H(added)	Clashes	Symm-Clashes
1	A	6186	0	6190	50	0
1	B	6185	0	6179	51	0
1	C	6193	0	6185	57	0
1	D	6223	0	6218	73	0
2	A	12	0	18	4	0
2	C	8	0	12	3	0

Continued on next page...

Continued from previous page...

Mol	Chain	Non-H	H(model)	H(added)	Clashes	Symm-Clashes
2	D	4	0	6	0	0
3	A	349	0	0	2	0
3	B	270	0	0	2	0
3	C	312	0	0	3	0
3	D	307	0	0	2	0
All	All	26049	0	24808	223	0

The all-atom clashscore is defined as the number of clashes found per 1000 atoms (including hydrogen atoms). The all-atom clashscore for this structure is 4.

All (223) close contacts within the same asymmetric unit are listed below, sorted by their clash magnitude.

Atom-1	Atom-2	Interatomic distance (Å)	Clash overlap (Å)
1:C:268:LYS:HD2	1:C:414:TYR:HB2	1.66	0.77
1:D:367:GLU:OE2	1:D:397:ARG:HD2	1.84	0.77
1:D:411:PRO:HG2	1:D:458:THR:HG21	1.71	0.72
1:A:533:LEU:HD13	1:A:535:SER:H	1.56	0.70
1:C:233:LEU:HD22	1:C:469:VAL:HG21	1.73	0.70
1:D:418:ILE:HG22	1:D:420:GLU:H	1.56	0.70
1:A:233:LEU:HG	1:A:469:VAL:HG21	1.73	0.69
1:C:308:ASP:HB3	1:C:311:ILE:HG13	1.76	0.68
1:B:538:LYS:HD3	1:B:539:MET:N	2.09	0.68
1:A:3:ASN:HB3	1:A:4:PRO:HD3	1.78	0.66
1:A:533:LEU:HD22	1:A:534:ASP:H	1.60	0.66
1:B:538:LYS:HD3	1:B:539:MET:H	1.61	0.66
1:C:239:LYS:HB2	1:C:245:ILE:HB	1.82	0.61
1:D:241:PRO:HD3	1:D:430:ALA:HB2	1.84	0.60
1:D:367:GLU:OE1	1:D:398:SER:N	2.31	0.60
1:D:406:LEU:HD21	1:D:433:ILE:HG22	1.84	0.58
1:D:291:ALA:HB1	1:D:294:LEU:HD12	1.84	0.58
1:A:552:ARG:HG3	1:A:553:ARG:H	1.69	0.58
1:C:284:LEU:HB3	1:C:356:VAL:HG22	1.87	0.57
1:D:418:ILE:H	1:D:418:ILE:HD12	1.70	0.57
1:D:400:ASP:HB3	1:D:434:LYS:HD2	1.87	0.56
1:D:362:VAL:HG23	1:D:366:TYR:HA	1.87	0.56
1:D:713:HIS:HA	1:D:787:ILE:HD13	1.86	0.56
1:D:391:ILE:O	1:D:424:PHE:HA	2.05	0.56
1:C:38:LEU:O	1:C:94:THR:HA	2.06	0.56
1:D:353:LYS:HB3	1:D:389:ARG:HD3	1.88	0.55
1:A:184:SER:OG	1:A:587:GLY:HA3	2.07	0.55
1:B:16:ASN:HA	1:B:782:LYS:HE2	1.89	0.55

Continued on next page...

Continued from previous page...

Atom-1	Atom-2	Interatomic distance (Å)	Clash overlap (Å)
1:C:209:VAL:HG11	1:C:489:LEU:HD13	1.88	0.55
1:A:191:ALA:HA	1:A:224:ILE:HD11	1.89	0.55
1:C:268:LYS:CD	1:C:414:TYR:HB2	2.34	0.55
1:D:381:ILE:HG23	1:D:405:HIS:HD2	1.71	0.55
1:D:201:ILE:HG21	1:D:301:GLY:HA3	1.89	0.55
1:B:38:LEU:O	1:B:94:THR:HA	2.07	0.54
1:C:268:LYS:HZ1	1:C:422:ARG:HH12	1.55	0.54
1:C:268:LYS:NZ	1:C:422:ARG:HH22	2.05	0.54
1:B:800:LYS:O	1:B:801:ILE:CG1	2.56	0.54
1:D:332:LYS:HG2	1:D:333:GLU:O	2.06	0.54
1:A:18:ARG:HH12	1:B:21:ILE:HB	1.73	0.54
1:C:564:LEU:HD13	1:C:603:TYR:CZ	2.44	0.52
1:D:9:PRO:HB3	1:D:639:VAL:HG22	1.90	0.52
1:C:268:LYS:HE3	1:C:412:GLN:HB3	1.92	0.52
1:C:705:LEU:HD11	1:C:795:ILE:HD13	1.91	0.52
1:C:110:TRP:CD1	1:C:148:CYS:HA	2.45	0.52
1:C:363:GLU:HG2	1:C:364:THR:HG23	1.91	0.51
1:B:800:LYS:O	1:B:801:ILE:HG12	2.11	0.51
1:D:308:ASP:HB3	1:D:311:ILE:HG13	1.92	0.51
1:C:132:LYS:HE3	3:C:1280:HOH:O	2.10	0.51
1:C:268:LYS:HD3	1:C:414:TYR:C	2.30	0.51
1:A:18:ARG:NH1	1:B:21:ILE:HB	2.26	0.51
1:B:268:LYS:HG2	1:B:269:LEU:HD12	1.93	0.51
1:B:184:SER:OG	1:B:587:GLY:HA3	2.11	0.51
1:D:172:TRP:CZ2	1:D:592:ALA:HB2	2.46	0.51
1:C:164:LEU:N	3:C:1002:HOH:O	2.35	0.51
1:A:268:LYS:HG3	1:A:269:LEU:HD12	1.92	0.50
1:B:496:LYS:HG3	1:B:559:TYR:CZ	2.46	0.50
1:B:415:GLY:O	1:B:418:ILE:HG13	2.11	0.50
1:C:172:TRP:CZ2	1:C:592:ALA:HB2	2.46	0.50
1:D:356:VAL:HB	1:D:391:ILE:HG23	1.93	0.50
1:C:168:ALA:HB1	1:D:643:THR:HG23	1.93	0.50
1:B:9:PRO:HB3	1:B:639:VAL:HG22	1.93	0.50
1:D:378:GLU:HG2	1:D:404:SER:HB2	1.92	0.50
1:D:374:GLN:NE2	1:D:403:VAL:HG12	2.27	0.50
1:B:172:TRP:CZ2	1:B:592:ALA:HB2	2.47	0.50
1:C:363:GLU:OE1	1:C:363:GLU:N	2.44	0.50
1:B:471:ASP:HB3	1:B:474:LYS:HG2	1.94	0.49
1:D:710:ILE:HD11	1:D:775:ALA:HA	1.94	0.49
1:A:617:ASP:C	2:A:901:EDO:H22	2.33	0.49
1:D:362:VAL:CG2	1:D:366:TYR:HA	2.42	0.49

Continued on next page...

Continued from previous page...

Atom-1	Atom-2	Interatomic distance (Å)	Clash overlap (Å)
1:D:38:LEU:O	1:D:94:THR:HA	2.12	0.49
1:C:17:GLU:O	1:C:21:ILE:HG12	2.12	0.49
1:A:38:LEU:O	1:A:94:THR:HA	2.12	0.49
1:A:443:TYR:HD1	1:A:444:MET:HE2	1.78	0.49
1:B:16:ASN:OD1	1:B:18:ARG:HB3	2.13	0.48
1:B:266:GLN:HB3	1:B:293:HIS:HB2	1.94	0.48
1:D:249:ILE:HG21	1:D:450:MET:HE1	1.96	0.48
1:A:746:ASP:HB3	2:A:901:EDO:H11	1.94	0.48
1:D:622:PRO:O	1:D:626:VAL:HG22	2.13	0.48
1:A:172:TRP:CZ2	1:A:592:ALA:HB2	2.49	0.48
1:B:361:TRP:CD1	1:B:366:TYR:CZ	3.02	0.48
1:C:473:LEU:HD13	1:C:502:PHE:HB2	1.95	0.48
1:D:374:GLN:CD	1:D:403:VAL:HG12	2.34	0.48
1:A:308:ASP:O	1:A:331:SER:HA	2.13	0.48
1:B:31:SER:O	1:B:147:LYS:HE3	2.13	0.48
1:D:471:ASP:HB3	1:D:474:LYS:HD3	1.96	0.48
1:B:236:PRO:HB2	1:B:247:PRO:HB3	1.96	0.48
1:D:382:ASP:HB3	1:D:405:HIS:CD2	2.48	0.48
1:B:538:LYS:HA	1:B:538:LYS:HE2	1.96	0.48
1:A:574:ILE:HD13	1:A:577:MET:HE3	1.96	0.47
1:A:747:ASN:ND2	2:A:901:EDO:H21	2.30	0.47
1:D:8:ILE:HA	1:D:9:PRO:C	2.35	0.47
1:B:391:ILE:HB	1:B:425:PHE:HB2	1.95	0.47
1:B:564:LEU:HD13	1:B:603:TYR:CZ	2.50	0.47
1:C:9:PRO:HB3	1:C:639:VAL:HG22	1.96	0.47
1:D:184:SER:OG	1:D:587:GLY:HA3	2.15	0.47
1:A:415:GLY:O	1:A:418:ILE:HG13	2.15	0.47
1:C:209:VAL:HG12	1:C:488:SER:HB2	1.97	0.47
1:A:18:ARG:NH1	1:B:18:ARG:HA	2.30	0.46
1:D:436:LEU:HD11	1:D:438:ALA:HB3	1.97	0.46
1:C:241:PRO:HD3	1:C:430:ALA:HB2	1.98	0.46
1:A:221:ARG:O	1:A:298:GLN:HG3	2.16	0.46
1:C:266:GLN:H	1:C:266:GLN:HG2	1.55	0.46
1:D:367:GLU:OE2	1:D:397:ARG:HA	2.15	0.46
1:C:328:ILE:HG13	1:C:348:MET:HE1	1.98	0.46
1:D:411:PRO:HB3	1:D:444:MET:HE3	1.97	0.46
1:B:264:ASN:HB3	1:B:267:ILE:HB	1.97	0.46
1:D:366:TYR:O	1:D:370:GLN:HG3	2.15	0.46
1:D:17:GLU:OE1	1:D:782:LYS:HE3	2.16	0.45
1:D:400:ASP:OD2	1:D:436:LEU:HD23	2.17	0.45
1:D:406:LEU:HD21	1:D:433:ILE:CG2	2.47	0.45

Continued on next page...

Continued from previous page...

Atom-1	Atom-2	Interatomic distance (Å)	Clash overlap (Å)
1:B:418:ILE:HD13	1:B:420:GLU:HG3	1.97	0.45
1:D:381:ILE:HG23	1:D:405:HIS:CD2	2.50	0.45
1:D:17:GLU:O	1:D:21:ILE:HG12	2.17	0.45
1:D:362:VAL:HG21	1:D:369:PHE:HB3	1.99	0.45
1:C:286:ILE:HG22	1:C:360:THR:CG2	2.46	0.45
1:C:634:ARG:HE	2:C:901:EDO:C2	2.30	0.45
1:A:688:CYS:O	1:A:761:ARG:NH1	2.50	0.45
1:D:299:LEU:HB2	1:D:323:THR:HB	1.99	0.45
1:D:264:ASN:HB2	1:D:267:ILE:HB	1.98	0.45
1:A:110:TRP:CD1	1:A:148:CYS:HA	2.52	0.45
1:A:139:PHE:HA	1:B:640:PRO:HB3	1.99	0.45
1:A:8:ILE:HA	1:A:9:PRO:C	2.37	0.45
1:C:268:LYS:CE	1:C:412:GLN:HB3	2.46	0.45
1:D:244:LEU:HB3	1:D:408:ALA:HB2	1.98	0.45
1:A:638:TYR:O	1:A:640:PRO:HD3	2.17	0.44
1:A:391:ILE:O	1:A:424:PHE:HA	2.16	0.44
1:C:356:VAL:HB	1:C:391:ILE:HG12	2.00	0.44
1:D:237:GLY:HA3	1:D:248:VAL:HG13	1.99	0.44
1:C:8:ILE:HA	1:C:9:PRO:C	2.36	0.44
1:A:369:PHE:CZ	1:A:373:LYS:HD3	2.53	0.44
1:B:308:ASP:HB3	1:B:311:ILE:HG13	2.00	0.44
1:D:477:LEU:HD11	1:D:502:PHE:CE1	2.53	0.44
1:B:110:TRP:CD1	1:B:148:CYS:HA	2.52	0.44
1:B:451:SER:OG	1:B:454:ASP:OD2	2.30	0.44
1:D:705:LEU:HD11	1:D:795:ILE:HD13	2.00	0.44
1:B:267:ILE:HA	1:B:270:LEU:HB2	2.00	0.44
1:B:269:LEU:HD23	1:B:293:HIS:CE1	2.53	0.44
1:C:350:GLN:HE22	1:C:385:SER:HB2	1.82	0.44
1:C:678:VAL:HG21	1:C:693:PHE:HB3	2.00	0.44
1:D:211:TYR:CE2	1:D:213:PRO:HG3	2.52	0.44
1:A:31:SER:O	1:A:147:LYS:HE3	2.18	0.43
1:A:311:ILE:O	1:A:331:SER:HB3	2.17	0.43
1:C:187:THR:HG23	1:C:224:ILE:HD11	1.99	0.43
1:B:678:VAL:HG21	1:B:693:PHE:HB3	2.01	0.43
1:A:24:PHE:CG	1:A:531:LEU:HD22	2.53	0.43
1:A:653:ASP:HB2	1:A:668:ILE:HG13	1.99	0.43
1:B:113:ARG:HD3	1:B:575:ASP:OD2	2.18	0.43
1:A:9:PRO:HB3	1:A:639:VAL:HG22	2.00	0.43
1:C:5:ASP:N	1:C:13:GLN:HE21	2.16	0.43
1:D:366:TYR:CD1	1:D:367:GLU:HG2	2.53	0.43
1:D:406:LEU:HG	1:D:406:LEU:O	2.18	0.43

Continued on next page...

Continued from previous page...

Atom-1	Atom-2	Interatomic distance (Å)	Clash overlap (Å)
1:D:516:GLY:HA3	1:D:602:TRP:CE3	2.52	0.43
1:A:648:ARG:HB2	3:A:1002:HOH:O	2.18	0.43
1:D:110:TRP:CD1	1:D:148:CYS:HA	2.54	0.43
1:D:407:LEU:HD23	1:D:426:HIS:CG	2.53	0.43
1:C:269:LEU:HB3	1:C:293:HIS:CE1	2.54	0.43
1:C:391:ILE:O	1:C:424:PHE:HA	2.19	0.43
1:A:342[A]:GLN:NE2	3:A:1024:HOH:O	2.52	0.43
1:B:417:SER:HA	1:B:448:THR:HG22	1.99	0.43
1:A:411:PRO:HB3	1:A:444:MET:HE3	2.00	0.43
1:A:705:LEU:HD11	1:A:795:ILE:HD13	2.00	0.43
1:C:501:LYS:HE2	1:C:505:ASP:OD1	2.18	0.43
1:B:308:ASP:O	1:B:331:SER:HA	2.19	0.42
1:B:391:ILE:O	1:B:424:PHE:HA	2.19	0.42
1:D:739:LEU:HA	1:D:739:LEU:HD23	1.94	0.42
1:C:286:ILE:HG22	1:C:360:THR:HG23	2.02	0.42
1:D:409:LEU:HD21	1:D:421:MET:SD	2.59	0.42
1:A:518:PRO:HD3	1:A:600:PHE:CE2	2.54	0.42
1:B:34:VAL:HB	1:B:90:VAL:HG22	2.01	0.42
1:D:275:PHE:CE1	1:D:276:MET:HE2	2.54	0.42
1:D:410:LEU:HD12	1:D:424:PHE:CE1	2.54	0.42
1:A:710:ILE:HD11	1:A:775:ALA:HA	2.01	0.42
1:C:373:LYS:NZ	3:C:1024:HOH:O	2.52	0.42
1:C:58:HIS:CE1	1:D:58:HIS:CE1	3.08	0.42
1:C:665:GLN:NE2	1:C:682:PHE:HB3	2.34	0.42
1:C:630:THR:CG2	2:C:901:EDO:H22	2.49	0.42
1:C:286:ILE:HB	1:C:358:ASP:HA	2.01	0.42
1:D:216:VAL:HA	1:D:226:PRO:HG3	2.01	0.42
1:D:40:HIS:HB3	3:D:1261:HOH:O	2.19	0.42
1:B:203:LYS:HD2	1:B:203:LYS:HA	1.82	0.42
1:D:477:LEU:HD23	1:D:477:LEU:HA	1.88	0.42
1:A:46:LYS:NZ	1:A:50:ASP:OD2	2.52	0.42
1:D:267:ILE:HA	1:D:267:ILE:HD12	1.88	0.42
1:C:443:TYR:HD2	1:C:444:MET:HE2	1.85	0.42
1:D:367:GLU:OE2	1:D:397:ARG:CD	2.63	0.42
1:A:356:VAL:HB	1:A:391:ILE:HG23	2.01	0.42
1:A:615:MET:HE2	1:A:615:MET:HA	2.01	0.41
1:C:268:LYS:CE	1:C:422:ARG:HH22	2.33	0.41
1:C:337:LYS:HD2	1:A:269:LEU:HD13	2.02	0.41
1:B:8:ILE:HA	1:B:9:PRO:C	2.40	0.41
1:C:268:LYS:HE2	1:C:414:TYR:H	1.84	0.41
1:A:115:SER:OG	1:A:147:LYS:HD3	2.21	0.41

Continued on next page...

Continued from previous page...

Atom-1	Atom-2	Interatomic distance (Å)	Clash overlap (Å)
1:B:407:LEU:HB2	1:B:426:HIS:HB3	2.02	0.41
1:B:626:VAL:HG23	1:B:627:LYS:HG2	2.02	0.41
1:D:147[B]:LYS:NZ	1:D:591:PHE:O	2.49	0.41
1:D:382:ASP:HB3	1:D:405:HIS:NE2	2.35	0.41
1:D:418:ILE:HG21	1:D:420:GLU:HG2	2.03	0.41
1:A:615:MET:HA	1:A:615:MET:CE	2.51	0.41
1:B:653:ASP:HB2	1:B:668:ILE:HG13	2.03	0.41
1:C:350:GLN:NE2	1:C:385:SER:HB2	2.36	0.41
1:D:284:LEU:HD21	1:D:334:PHE:CE1	2.56	0.41
1:A:58:HIS:CE1	1:B:58:HIS:CE1	3.09	0.41
1:C:713:HIS:HA	1:C:787:ILE:HD13	2.03	0.41
1:A:220:LEU:HD13	1:A:220:LEU:HA	1.85	0.41
1:C:268:LYS:HE3	1:C:422:ARG:HH22	1.86	0.41
1:C:634:ARG:HE	2:C:901:EDO:H21	1.85	0.41
1:B:311:ILE:O	1:B:331:SER:HB3	2.20	0.41
1:C:382:ASP:OD2	1:C:405:HIS:NE2	2.50	0.41
1:C:611:LYS:HG2	1:C:612:ARG:HG2	2.02	0.41
1:D:443:TYR:HD1	1:D:444:MET:HE2	1.86	0.41
1:D:487:TYR:HE2	1:D:556:ASP:HB2	1.84	0.41
1:A:552:ARG:HD3	1:A:552:ARG:HA	1.89	0.40
1:A:48:ALA:CB	1:A:59:VAL:HG11	2.51	0.40
1:A:444:MET:HG3	2:A:903:EDO:H21	2.03	0.40
1:B:471:ASP:HB3	1:B:474:LYS:CG	2.51	0.40
1:B:747:ASN:HB2	1:B:755:LEU:HD11	2.02	0.40
1:B:201:ILE:HG12	3:B:1126:HOH:O	2.21	0.40
1:B:477:LEU:HB3	1:B:511:ALA:HB2	2.03	0.40
1:B:655:TYR:HB2	3:B:1164:HOH:O	2.20	0.40
1:C:172:TRP:HZ2	1:C:592:ALA:HB2	1.83	0.40
1:D:246:LEU:HD22	1:D:443:TYR:CG	2.57	0.40
1:D:681:HIS:HB2	3:D:1013:HOH:O	2.20	0.40
1:B:267:ILE:HD12	1:B:267:ILE:HA	1.97	0.40

There are no symmetry-related clashes.

5.3 Torsion angles

5.3.1 Protein backbone

In the following table, the Percentiles column shows the percent Ramachandran outliers of the chain as a percentile score with respect to all X-ray entries followed by that with respect to entries of similar resolution.

The Analysed column shows the number of residues for which the backbone conformation was analysed, and the total number of residues.

Mol	Chain	Analysed	Favoured	Allowed	Outliers	Percentiles	
1	A	769/804 (96%)	752 (98%)	17 (2%)	0	100	100
1	B	772/804 (96%)	750 (97%)	22 (3%)	0	100	100
1	C	773/804 (96%)	755 (98%)	18 (2%)	0	100	100
1	D	774/804 (96%)	752 (97%)	22 (3%)	0	100	100
All	All	3088/3216 (96%)	3009 (97%)	79 (3%)	0	100	100

There are no Ramachandran outliers to report.

5.3.2 Protein sidechains [i](#)

In the following table, the Percentiles column shows the percent sidechain outliers of the chain as a percentile score with respect to all X-ray entries followed by that with respect to entries of similar resolution.

The Analysed column shows the number of residues for which the sidechain conformation was analysed, and the total number of residues.

Mol	Chain	Analysed	Rotameric	Outliers	Percentiles	
1	A	687/711 (97%)	683 (99%)	4 (1%)	86	90
1	B	688/711 (97%)	678 (98%)	10 (2%)	65	71
1	C	689/711 (97%)	679 (98%)	10 (2%)	65	71
1	D	692/711 (97%)	675 (98%)	17 (2%)	47	52
All	All	2756/2844 (97%)	2715 (98%)	41 (2%)	65	71

All (41) residues with a non-rotameric sidechain are listed below:

Mol	Chain	Res	Type
1	C	18	ARG
1	C	147	LYS
1	C	163	SER
1	C	184	SER
1	C	285	TYR
1	C	371	SER
1	C	528	LYS
1	C	534	ASP
1	C	717	SER
1	C	757	ARG

Continued on next page...

Continued from previous page...

Mol	Chain	Res	Type
1	A	285	TYR
1	A	541	LYS
1	A	553	ARG
1	A	793	SER
1	B	134	GLU
1	B	147	LYS
1	B	169	ARG
1	B	285	TYR
1	B	365	ASP
1	B	367	GLU
1	B	402	SER
1	B	481	ARG
1	B	702	SER
1	B	800	LYS
1	D	96[A]	ASP
1	D	96[B]	ASP
1	D	231	LYS
1	D	285	TYR
1	D	366	TYR
1	D	383	ARG
1	D	394	LYS
1	D	402	SER
1	D	407	LEU
1	D	419	ARG
1	D	432	ASP
1	D	436	LEU
1	D	441	GLU
1	D	534	ASP
1	D	566	ASP
1	D	626	VAL
1	D	748	LYS

Some sidechains can be flipped to improve hydrogen bonding and reduce clashes. All (3) such sidechains are listed below:

Mol	Chain	Res	Type
1	C	350	GLN
1	B	167	ASN
1	D	405	HIS

5.3.3 RNA [i](#)

There are no RNA molecules in this entry.

5.4 Non-standard residues in protein, DNA, RNA chains [i](#)

There are no non-standard protein/DNA/RNA residues in this entry.

5.5 Carbohydrates [i](#)

There are no carbohydrates in this entry.

5.6 Ligand geometry [i](#)

6 ligands are modelled in this entry.

In the following table, the Counts columns list the number of bonds (or angles) for which Mogul statistics could be retrieved, the number of bonds (or angles) that are observed in the model and the number of bonds (or angles) that are defined in the Chemical Component Dictionary. The Link column lists molecule types, if any, to which the group is linked. The Z score for a bond length (or angle) is the number of standard deviations the observed value is removed from the expected value. A bond length (or angle) with $|Z| > 2$ is considered an outlier worth inspection. RMSZ is the root-mean-square of all Z scores of the bond lengths (or angles).

Mol	Type	Chain	Res	Link	Bond lengths			Bond angles		
					Counts	RMSZ	$\# Z > 2$	Counts	RMSZ	$\# Z > 2$
2	EDO	A	901	-	3,3,3	0.38	0	2,2,2	0.30	0
2	EDO	D	901	-	3,3,3	0.67	0	2,2,2	0.20	0
2	EDO	C	901	-	3,3,3	0.50	0	2,2,2	0.42	0
2	EDO	A	902	-	3,3,3	0.44	0	2,2,2	0.47	0
2	EDO	C	902	-	3,3,3	0.56	0	2,2,2	0.09	0
2	EDO	A	903	-	3,3,3	0.47	0	2,2,2	0.37	0

In the following table, the Chirals column lists the number of chiral outliers, the number of chiral centers analysed, the number of these observed in the model and the number defined in the Chemical Component Dictionary. Similar counts are reported in the Torsion and Rings columns. '-' means no outliers of that kind were identified.

Mol	Type	Chain	Res	Link	Chirals	Torsions	Rings
2	EDO	A	901	-	-	0/1/1/1	-
2	EDO	D	901	-	-	0/1/1/1	-
2	EDO	C	901	-	-	0/1/1/1	-
2	EDO	A	902	-	-	1/1/1/1	-

Continued on next page...

Continued from previous page...

Mol	Type	Chain	Res	Link	Chirals	Torsions	Rings
2	EDO	C	902	-	-	1/1/1/1	-
2	EDO	A	903	-	-	0/1/1/1	-

There are no bond length outliers.

There are no bond angle outliers.

There are no chirality outliers.

All (2) torsion outliers are listed below:

Mol	Chain	Res	Type	Atoms
2	C	902	EDO	O1-C1-C2-O2
2	A	902	EDO	O1-C1-C2-O2

There are no ring outliers.

3 monomers are involved in 7 short contacts:

Mol	Chain	Res	Type	Clashes	Symm-Clashes
2	A	901	EDO	3	0
2	C	901	EDO	3	0
2	A	903	EDO	1	0

5.7 Other polymers [i](#)

There are no such residues in this entry.

5.8 Polymer linkage issues [i](#)

There are no chain breaks in this entry.

6 Fit of model and data

6.1 Protein, DNA and RNA chains

In the following table, the column labelled ‘#RSRZ> 2’ contains the number (and percentage) of RSRZ outliers, followed by percent RSRZ outliers for the chain as percentile scores relative to all X-ray entries and entries of similar resolution. The OWAB column contains the minimum, median, 95th percentile and maximum values of the occupancy-weighted average B-factor per residue. The column labelled ‘Q< 0.9’ lists the number of (and percentage) of residues with an average occupancy less than 0.9.

Mol	Chain	Analysed	<RSRZ>	#RSRZ>2	OWAB(Å ²)	Q<0.9
1	A	776/804 (96%)	-0.15	16 (2%) 63 68	21, 32, 51, 76	0
1	B	778/804 (96%)	0.01	31 (3%) 38 44	21, 36, 62, 79	0
1	C	779/804 (96%)	-0.04	15 (1%) 66 71	17, 33, 55, 76	0
1	D	778/804 (96%)	0.35	80 (10%) 6 8	19, 34, 80, 94	0
All	All	3111/3216 (96%)	0.04	142 (4%) 32 38	17, 34, 65, 94	0

All (142) RSRZ outliers are listed below:

Mol	Chain	Res	Type	RSRZ
1	D	415	GLY	7.6
1	B	535	SER	6.8
1	D	443	TYR	5.7
1	C	554	TRP	5.6
1	B	554	TRP	5.5
1	D	234	PRO	5.5
1	A	533	LEU	5.1
1	D	239	LYS	5.0
1	D	409	LEU	4.9
1	D	400	ASP	4.7
1	D	398	SER	4.7
1	D	361	TRP	4.7
1	D	447	PHE	4.6
1	D	399	LYS	4.5
1	D	235	ASN	4.5
1	D	461	PHE	4.5
1	A	233	LEU	4.4
1	D	438	ALA	4.3
1	D	449	ALA	4.3
1	D	364	THR	4.1
1	C	547	SER	4.1

Continued on next page...

Continued from previous page...

Mol	Chain	Res	Type	RSRZ
1	D	339	PHE	4.1
1	D	448	THR	4.1
1	B	801	ILE	4.0
1	B	235	ASN	4.0
1	D	489	LEU	4.0
1	D	458	THR	3.9
1	D	419	ARG	3.9
1	C	265	PRO	3.9
1	D	436	LEU	3.9
1	A	552	ARG	3.9
1	D	351	ASN	3.8
1	D	363	GLU	3.8
1	D	362	VAL	3.8
1	D	341	VAL	3.7
1	C	233	LEU	3.6
1	B	574	ILE	3.6
1	D	384	THR	3.5
1	D	488	SER	3.5
1	D	441	GLU	3.5
1	D	535	SER	3.5
1	C	232	SER	3.4
1	D	366	TYR	3.4
1	D	380	LEU	3.4
1	B	533	LEU	3.3
1	D	242	PHE	3.3
1	D	334	PHE	3.3
1	B	237	GLY	3.3
1	B	438	ALA	3.2
1	B	624	ALA	3.2
1	D	437	ALA	3.2
1	D	249	ILE	3.2
1	D	350	GLN	3.2
1	B	83	LEU	3.2
1	A	3	ASN	3.1
1	D	396	ASN	3.1
1	D	418	ILE	3.1
1	C	234	PRO	3.1
1	D	431	SER	3.1
1	B	534	ASP	3.0
1	C	536	ALA	3.0
1	B	628	CYS	3.0
1	B	752	SER	2.9

Continued on next page...

Continued from previous page...

Mol	Chain	Res	Type	RSRZ
1	A	249	ILE	2.9
1	D	452	VAL	2.9
1	A	554	TRP	2.9
1	D	338	SER	2.9
1	A	574	ILE	2.8
1	C	534	ASP	2.8
1	D	434	LYS	2.8
1	B	84	LEU	2.8
1	D	439	GLU	2.8
1	B	361	TRP	2.7
1	A	234	PRO	2.7
1	B	234	PRO	2.7
1	C	535	SER	2.7
1	B	753	GLY	2.7
1	D	385	SER	2.7
1	D	406	LEU	2.7
1	B	547	SER	2.6
1	D	246	LEU	2.6
1	B	364	THR	2.6
1	D	554	TRP	2.6
1	D	411	PRO	2.6
1	A	84	LEU	2.6
1	A	624	ALA	2.5
1	D	401	THR	2.5
1	B	751	PRO	2.5
1	D	349	PHE	2.5
1	A	572	ILE	2.5
1	B	263	HIS	2.5
1	B	625	LEU	2.5
1	C	235	ASN	2.5
1	C	533	LEU	2.5
1	D	487	TYR	2.5
1	D	424	PHE	2.5
1	B	233	LEU	2.4
1	D	237	GLY	2.4
1	D	395	TRP	2.4
1	D	417	SER	2.4
1	C	436	LEU	2.4
1	C	689	GLY	2.4
1	B	800	LYS	2.4
1	D	459	GLN	2.4
1	D	456	ILE	2.4

Continued on next page...

Continued from previous page...

Mol	Chain	Res	Type	RSRZ
1	B	249	ILE	2.3
1	D	445	ASP	2.3
1	B	623	ALA	2.3
1	D	33	LEU	2.2
1	D	165	ALA	2.2
1	D	407	LEU	2.2
1	A	573	THR	2.2
1	D	336	PHE	2.2
1	D	233	LEU	2.2
1	A	628	CYS	2.2
1	D	84	LEU	2.2
1	A	689	GLY	2.2
1	A	121	ASN	2.2
1	B	449	ALA	2.2
1	D	365	ASP	2.2
1	D	432	ASP	2.2
1	C	364	THR	2.2
1	D	343	ALA	2.2
1	C	361	TRP	2.2
1	B	451	SER	2.2
1	D	422	ARG	2.2
1	D	331	SER	2.1
1	A	625	LEU	2.1
1	D	265	PRO	2.1
1	D	404	SER	2.1
1	B	124	VAL	2.1
1	D	430	ALA	2.1
1	D	244	LEU	2.1
1	D	32	PRO	2.0
1	D	377	PHE	2.0
1	D	121	ASN	2.0
1	D	547	SER	2.0
1	D	337	LYS	2.0
1	D	450	MET	2.0
1	B	436	LEU	2.0
1	B	573	THR	2.0
1	D	416	ALA	2.0

6.2 Non-standard residues in protein, DNA, RNA chains

There are no non-standard protein/DNA/RNA residues in this entry.

6.3 Carbohydrates [i](#)

There are no carbohydrates in this entry.

6.4 Ligands [i](#)

In the following table, the Atoms column lists the number of modelled atoms in the group and the number defined in the chemical component dictionary. The B-factors column lists the minimum, median, 95th percentile and maximum values of B factors of atoms in the group. The column labelled 'Q< 0.9' lists the number of atoms with occupancy less than 0.9.

Mol	Type	Chain	Res	Atoms	RSCC	RSR	B-factors(Å ²)	Q<0.9
2	EDO	D	901	4/4	0.88	0.14	31,31,33,36	0
2	EDO	C	901	4/4	0.93	0.13	31,33,37,40	0
2	EDO	A	902	4/4	0.93	0.44	31,37,39,45	0
2	EDO	C	902	4/4	0.93	0.15	33,35,39,40	0
2	EDO	A	901	4/4	0.96	0.14	30,31,35,36	0
2	EDO	A	903	4/4	0.98	0.14	40,41,42,50	0

6.5 Other polymers [i](#)

There are no such residues in this entry.