



## Full wwPDB EM Validation Report ⓘ

Apr 30, 2024 – 12:31 AM JST

PDB ID : 8XOW  
EMDB ID : EMD-38542  
Title : Mature virion portal of bacteriophage lambda  
Authors : Wang, J.W.; Gu, Z.W.  
Deposited on : 2024-01-02  
Resolution : 3.32 Å (reported)

This is a Full wwPDB EM Validation Report for a publicly released PDB entry.

We welcome your comments at [validation@mail.wwpdb.org](mailto:validation@mail.wwpdb.org)

A user guide is available at

<https://www.wwpdb.org/validation/2017/EMValidationReportHelp>

with specific help available everywhere you see the ⓘ symbol.

The types of validation reports are described at

<http://www.wwpdb.org/validation/2017/FAQs#types>.

---

The following versions of software and data (see [references ⓘ](#)) were used in the production of this report:

EMDB validation analysis : 0.0.1.dev92  
MolProbity : 4.02b-467  
Percentile statistics : 20191225.v01 (using entries in the PDB archive December 25th 2019)  
MapQ : 1.9.13  
Ideal geometry (proteins) : Engh & Huber (2001)  
Ideal geometry (DNA, RNA) : Parkinson et al. (1996)  
Validation Pipeline (wwPDB-VP) : 2.36.2

# 1 Overall quality at a glance i

The following experimental techniques were used to determine the structure:  
*ELECTRON MICROSCOPY*

The reported resolution of this entry is 3.32 Å.

Percentile scores (ranging between 0-100) for global validation metrics of the entry are shown in the following graphic. The table shows the number of entries on which the scores are based.

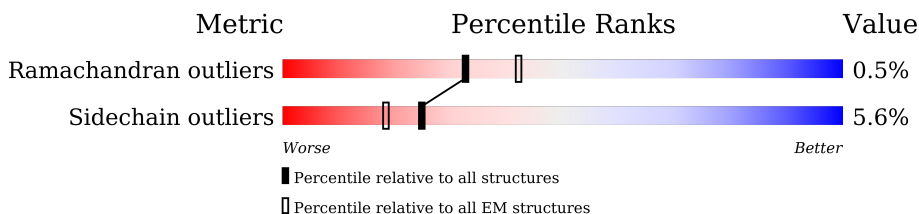

Metric	Whole archive (#Entries)	EM structures (#Entries)
Ramachandran outliers	154571	4023
Sidechain outliers	154315	3826

The table below summarises the geometric issues observed across the polymeric chains and their fit to the map. The red, orange, yellow and green segments of the bar indicate the fraction of residues that contain outliers for  $\geq 3$ , 2, 1 and 0 types of geometric quality criteria respectively. A grey segment represents the fraction of residues that are not modelled. The numeric value for each fraction is indicated below the corresponding segment, with a dot representing fractions  $\leq 5\%$ . The upper red bar (where present) indicates the fraction of residues that have poor fit to the EM map (all-atom inclusion  $< 40\%$ ). The numeric value is given above the bar.

Mol	Chain	Length	Quality of chain
1	f	117	 9% 91% 6% .
1	f1	117	 9% 92% 5% .
1	f2	117	 7% 93% . .
1	f3	117	 9% 90% 8% .
1	f4	117	 9% 91% 7% .
1	f5	117	 6% 91% 6% .
2	W	68	 16% 94% . .
2	W1	68	 18% 93% 6% .
2	W2	68	 16% 87% 12% .



*Continued on next page...*

Continued from previous page...

Mol	Chain	Length	Quality of chain
2	W3	68	21% 91% 7%
2	W4	68	18% 94% ..
2	W5	68	18% 87% 12%
2	w	68	18% 94% ..
2	w1	68	15% 87% 12%
2	w2	68	19% 88% 10%
2	w3	68	15% 88% 10%
2	w4	68	18% 96% ..
2	w5	68	16% 87% 12%
3	U	131	11% 90% 8%
3	U1	131	12% 91% 8%
3	U2	131	14% 91% 8%
3	U3	131	14% 89% 10%
3	U4	131	12% 89% 11%
3	U5	131	15% 91% 8%
4	B	533	23% 85% 11%
4	B1	533	23% 86% 11%
4	B2	533	21% 87% 11%
4	B3	533	22% 86% 11%
4	B4	533	23% 86% 11%
4	B5	533	22% 84% 5% 11%
4	b	533	23% 85% 11%
4	b1	533	23% 85% 11%
4	b2	533	23% 85% 11%
4	b3	533	22% 85% 11%

Continued on next page...

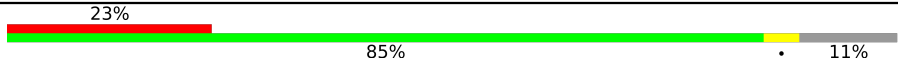
*Continued from previous page...*

Mol	Chain	Length	Quality of chain
4	b4	533	
4	b5	533	

## 2 Entry composition [i](#)

There are 4 unique types of molecules in this entry. The entry contains 62334 atoms, of which 0 are hydrogens and 0 are deuteriums.

In the tables below, the AltConf column contains the number of residues with at least one atom in alternate conformation and the Trace column contains the number of residues modelled with at most 2 atoms.

- Molecule 1 is a protein called Head-tail connector protein FII.

Mol	Chain	Residues	Atoms					AltConf	Trace
			Total	C	N	O	S		
1	f	114	872	535	161	174	2	0	0
1	f1	114	872	535	161	174	2	0	0
1	f2	114	872	535	161	174	2	0	0
1	f3	114	872	535	161	174	2	0	0
1	f4	114	872	535	161	174	2	0	0
1	f5	114	872	535	161	174	2	0	0

- Molecule 2 is a protein called Head completion protein.

Mol	Chain	Residues	Atoms					AltConf	Trace
			Total	C	N	O	S		
2	W	67	524	323	101	98	2	0	0
2	w	67	524	323	101	98	2	0	0
2	W1	67	524	323	101	98	2	0	0
2	w1	67	524	323	101	98	2	0	0
2	W2	67	524	323	101	98	2	0	0
2	w2	67	524	323	101	98	2	0	0
2	W3	67	524	323	101	98	2	0	0
2	w3	67	524	323	101	98	2	0	0
2	W4	67	524	323	101	98	2	0	0

*Continued on next page...*

*Continued from previous page...*

Mol	Chain	Residues	Atoms					AltConf	Trace
2	w4	67	Total	C	N	O	S	0	0
			524	323	101	98	2		
2	W5	67	Total	C	N	O	S	0	0
			524	323	101	98	2		
2	w5	67	Total	C	N	O	S	0	0
			524	323	101	98	2		

- Molecule 3 is a protein called Tail tube terminator protein.

Mol	Chain	Residues	Atoms					AltConf	Trace
3	U	131	Total	C	N	O	S	0	0
			1032	655	159	213	5		
3	U1	131	Total	C	N	O	S	0	0
			1032	655	159	213	5		
3	U2	131	Total	C	N	O	S	0	0
			1032	655	159	213	5		
3	U3	131	Total	C	N	O	S	0	0
			1032	655	159	213	5		
3	U4	131	Total	C	N	O	S	0	0
			1032	655	159	213	5		
3	U5	131	Total	C	N	O	S	0	0
			1032	655	159	213	5		

- Molecule 4 is a protein called Portal protein B.

Mol	Chain	Residues	Atoms					AltConf	Trace
4	B	475	Total	C	N	O	S	0	0
			3727	2328	671	704	24		
4	b	473	Total	C	N	O	S	0	0
			3710	2316	669	701	24		
4	B1	475	Total	C	N	O	S	0	0
			3727	2328	671	704	24		
4	b1	473	Total	C	N	O	S	0	0
			3710	2316	669	701	24		
4	B2	475	Total	C	N	O	S	0	0
			3727	2328	671	704	24		
4	b2	473	Total	C	N	O	S	0	0
			3710	2316	669	701	24		
4	B3	475	Total	C	N	O	S	0	0
			3727	2328	671	704	24		
4	b3	473	Total	C	N	O	S	0	0
			3710	2316	669	701	24		

*Continued on next page...*

*Continued from previous page...*

Mol	Chain	Residues	Atoms					AltConf	Trace
			Total	C	N	O	S		
4	B4	475	Total 3727	2328	671	704	24	0	0
4	b4	473	Total 3710	2316	669	701	24	0	0
4	B5	475	Total 3727	2328	671	704	24	0	0
4	b5	473	Total 3710	2316	669	701	24	0	0

### 3 Residue-property plots [i](#)

These plots are drawn for all protein, RNA, DNA and oligosaccharide chains in the entry. The first graphic for a chain summarises the proportions of the various outlier classes displayed in the second graphic. The second graphic shows the sequence view annotated by issues in geometry and atom inclusion in map density. Residues are color-coded according to the number of geometric quality criteria for which they contain at least one outlier: green = 0, yellow = 1, orange = 2 and red = 3 or more. A red diamond above a residue indicates a poor fit to the EM map for this residue (all-atom inclusion < 40%). Stretches of 2 or more consecutive residues without any outlier are shown as a green connector. Residues present in the sample, but not in the model, are shown in grey.

- Molecule 1: Head-tail connector protein FII

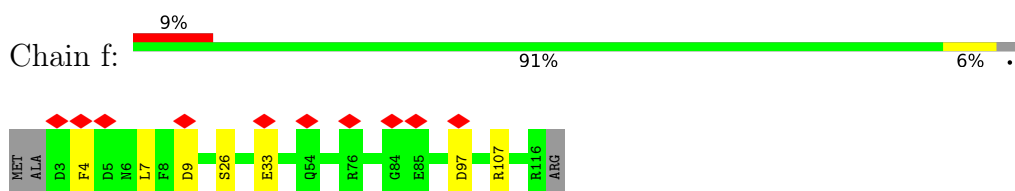

- Molecule 1: Head-tail connector protein FII

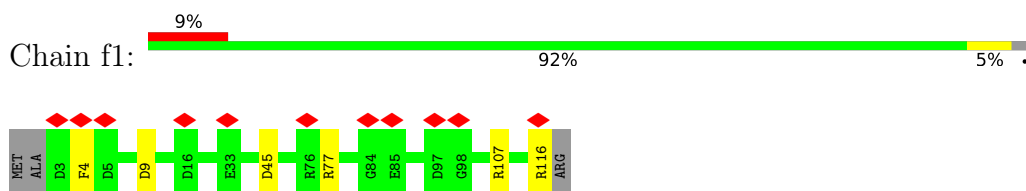

- Molecule 1: Head-tail connector protein FII

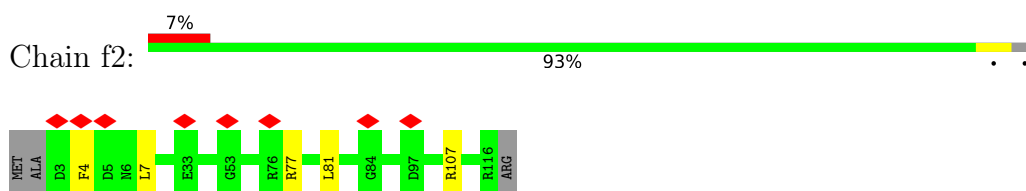

- Molecule 1: Head-tail connector protein FII

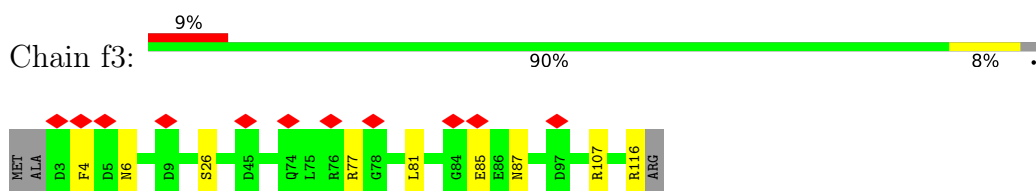

- Molecule 1: Head-tail connector protein FII

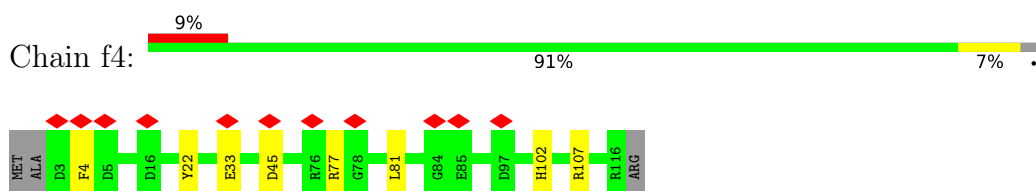



- Molecule 1: Head-tail connector protein FII

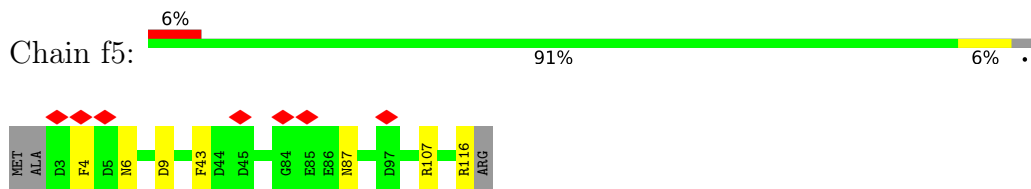

- Molecule 2: Head completion protein

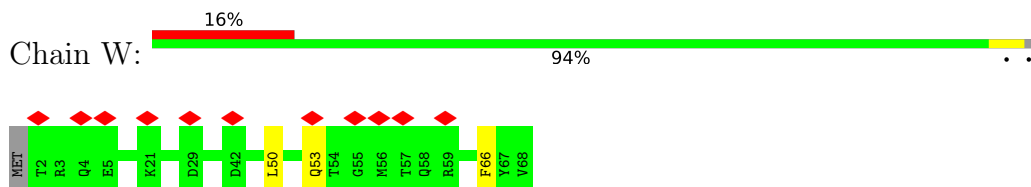

- Molecule 2: Head completion protein

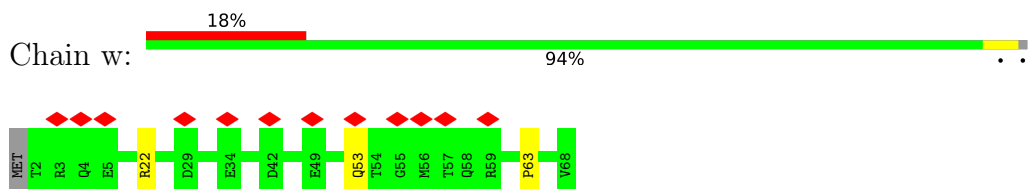

- Molecule 2: Head completion protein

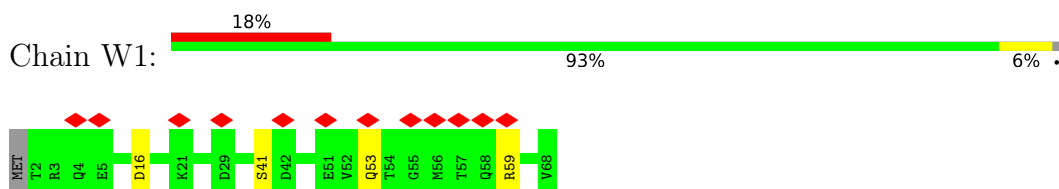

- Molecule 2: Head completion protein

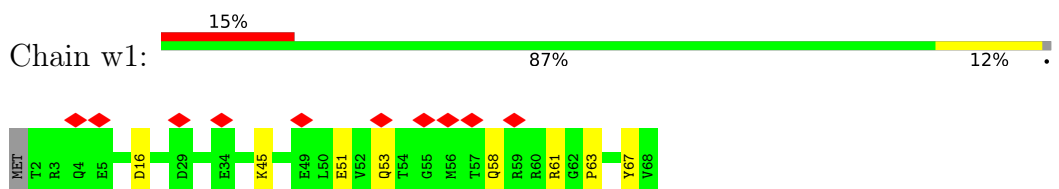

- Molecule 2: Head completion protein

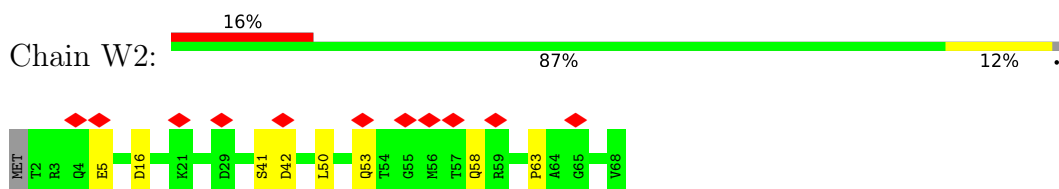

- Molecule 2: Head completion protein

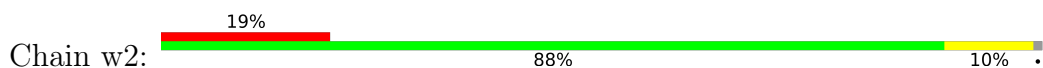



• Molecule 2: Head completion protein

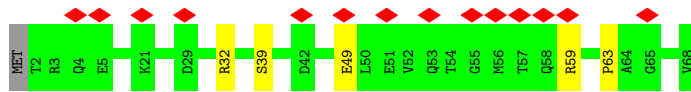
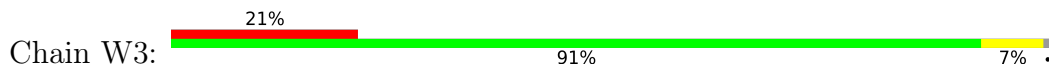

• Molecule 2: Head completion protein

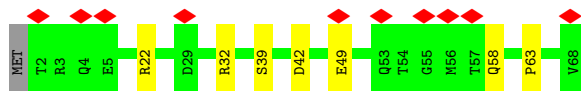
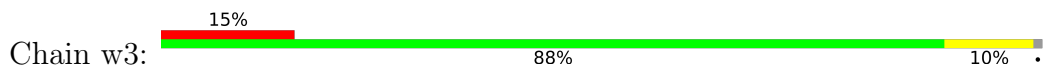

• Molecule 2: Head completion protein

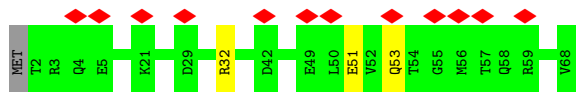

• Molecule 2: Head completion protein

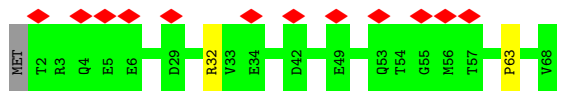

• Molecule 2: Head completion protein

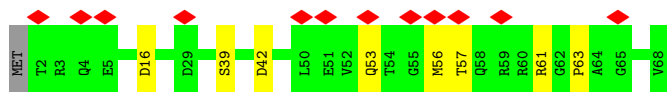
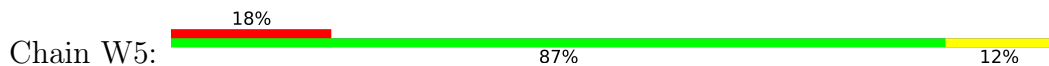

• Molecule 2: Head completion protein

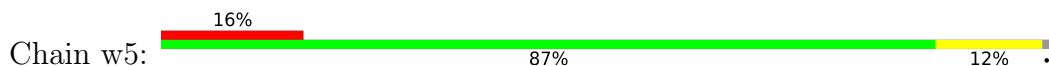

• Molecule 3: Tail tube terminator protein

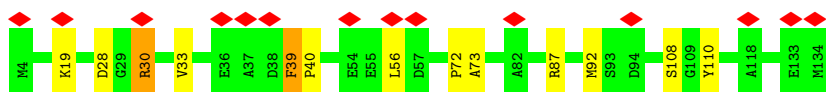
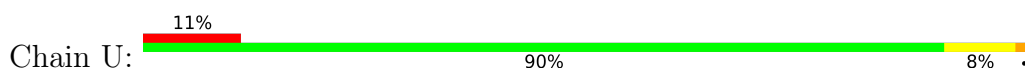

• Molecule 3: Tail tube terminator protein



• Molecule 3: Tail tube terminator protein

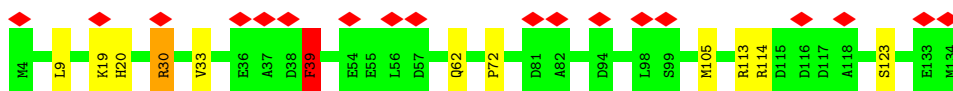
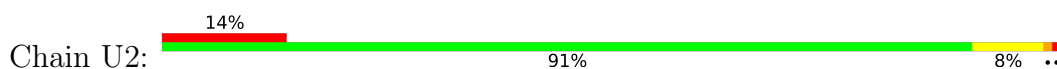

• Molecule 3: Tail tube terminator protein

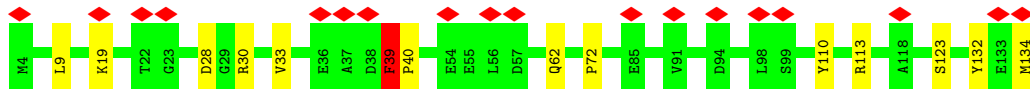
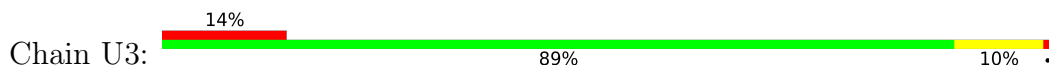

• Molecule 3: Tail tube terminator protein

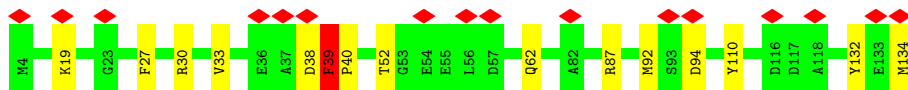
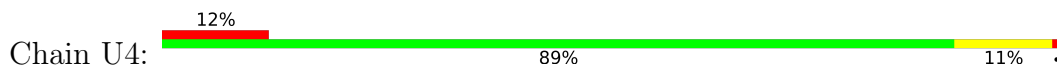

• Molecule 3: Tail tube terminator protein

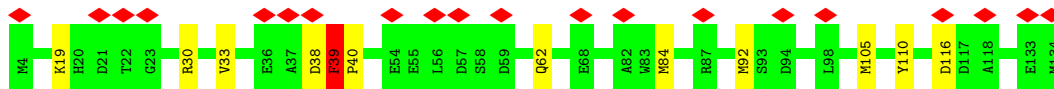
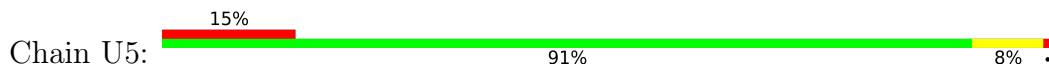

• Molecule 4: Portal protein B

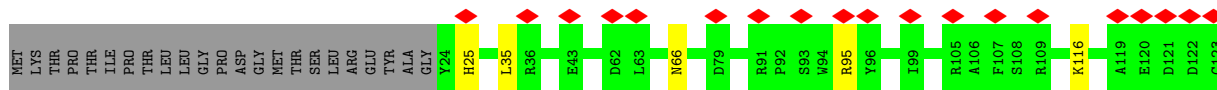
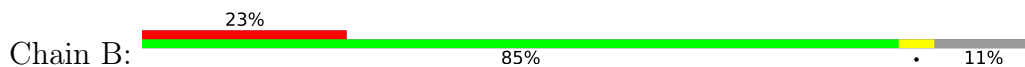

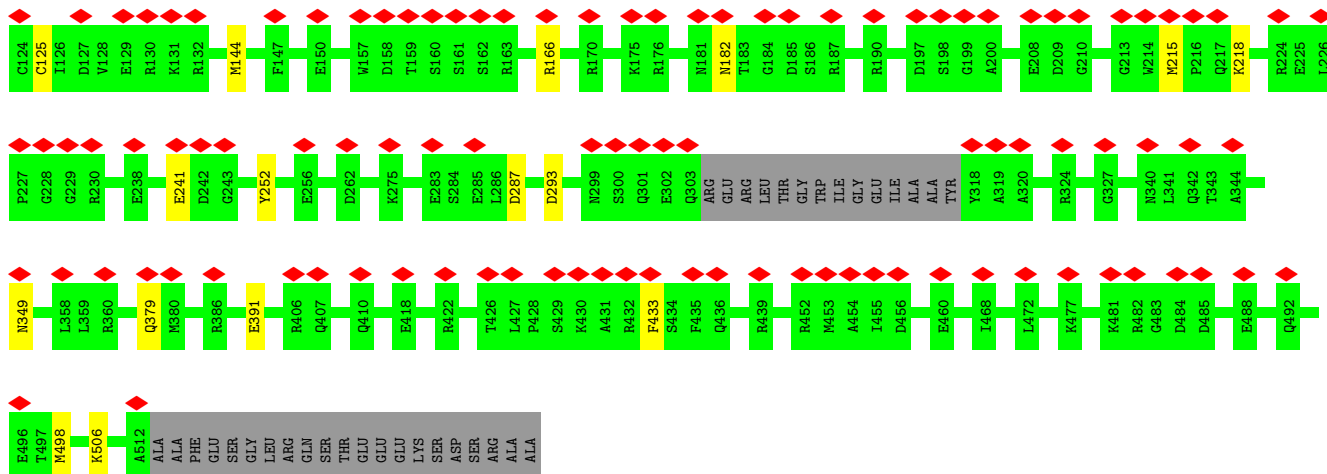

• Molecule 4: Portal protein B

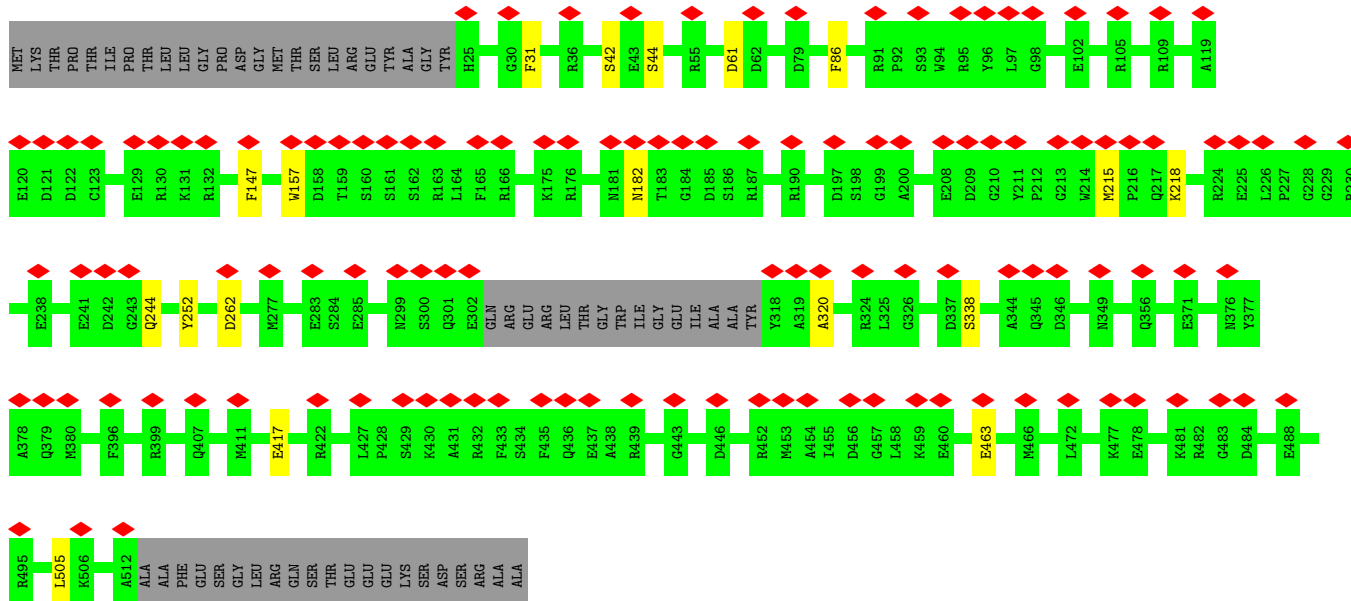
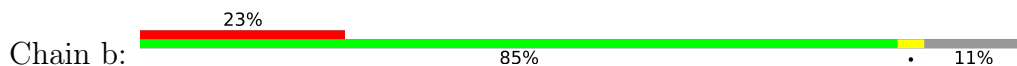

• Molecule 4: Portal protein B

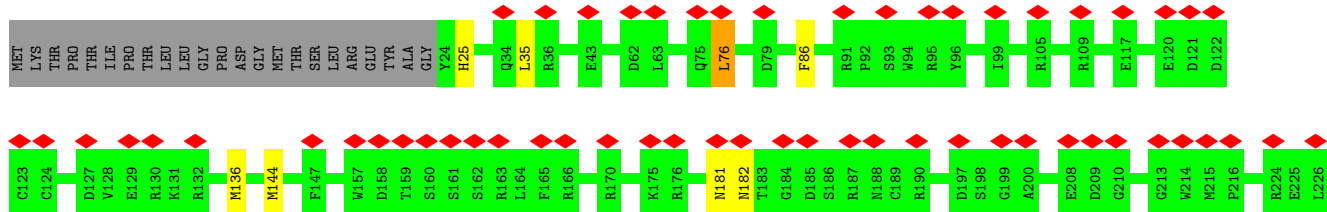
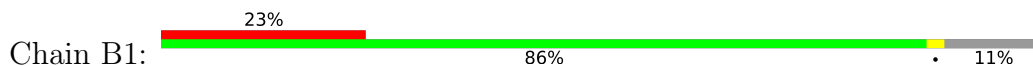



GLY  
LEU  
ARG  
GLN  
SER  
THR  
THR  
GLU  
GLU  
GLU  
LYS  
SER  
ASP  
SER  
ARG  
ALA  
ALA

• Molecule 4: Portal protein B

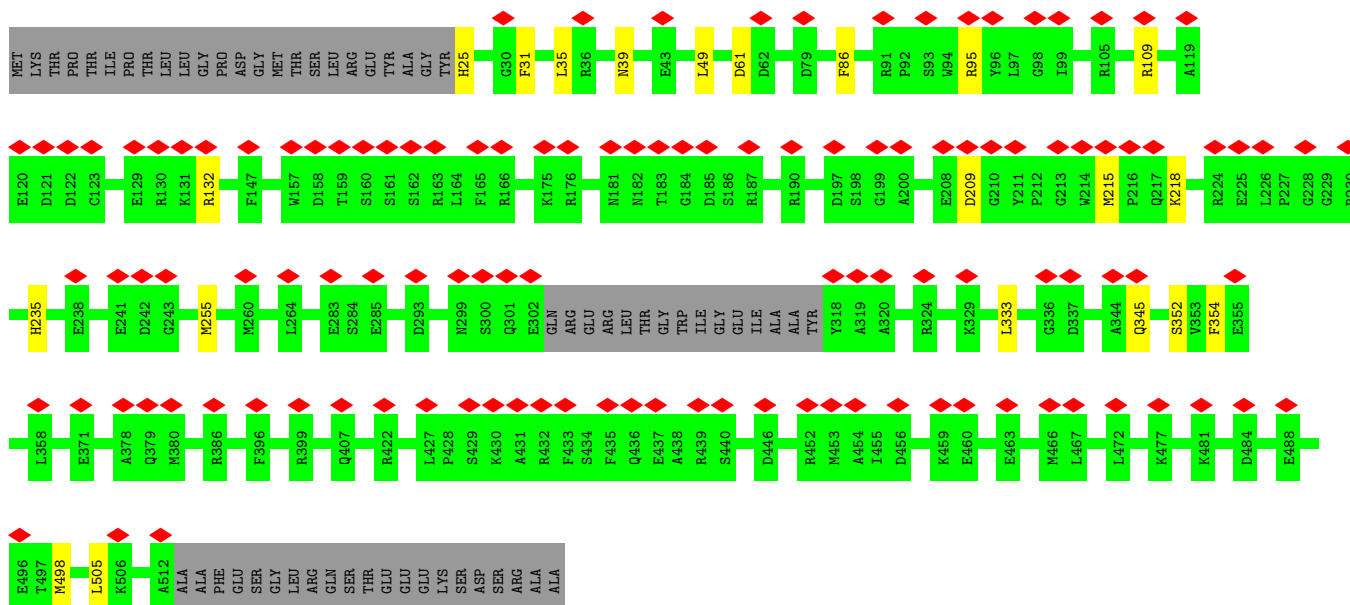
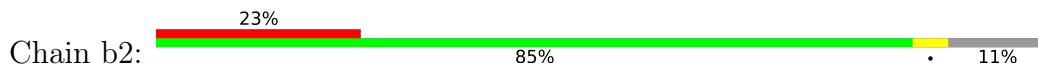

• Molecule 4: Portal protein B

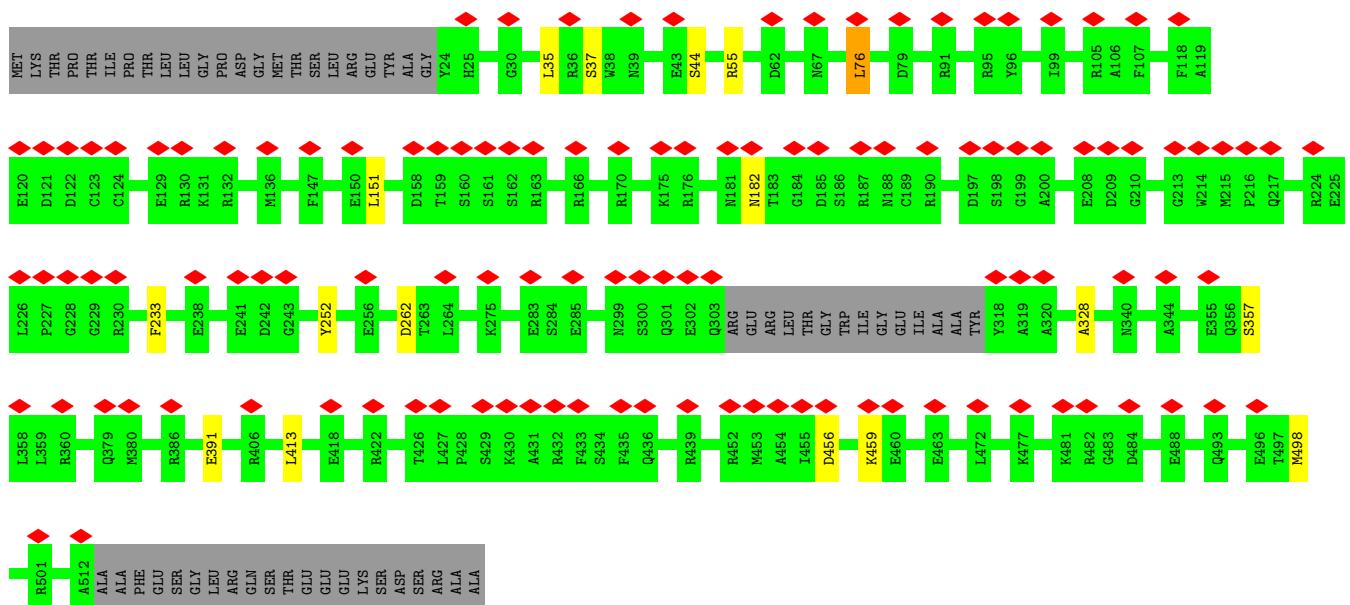
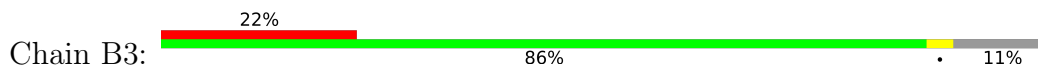

• Molecule 4: Portal protein B

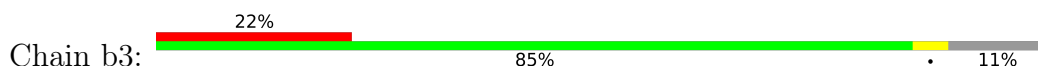

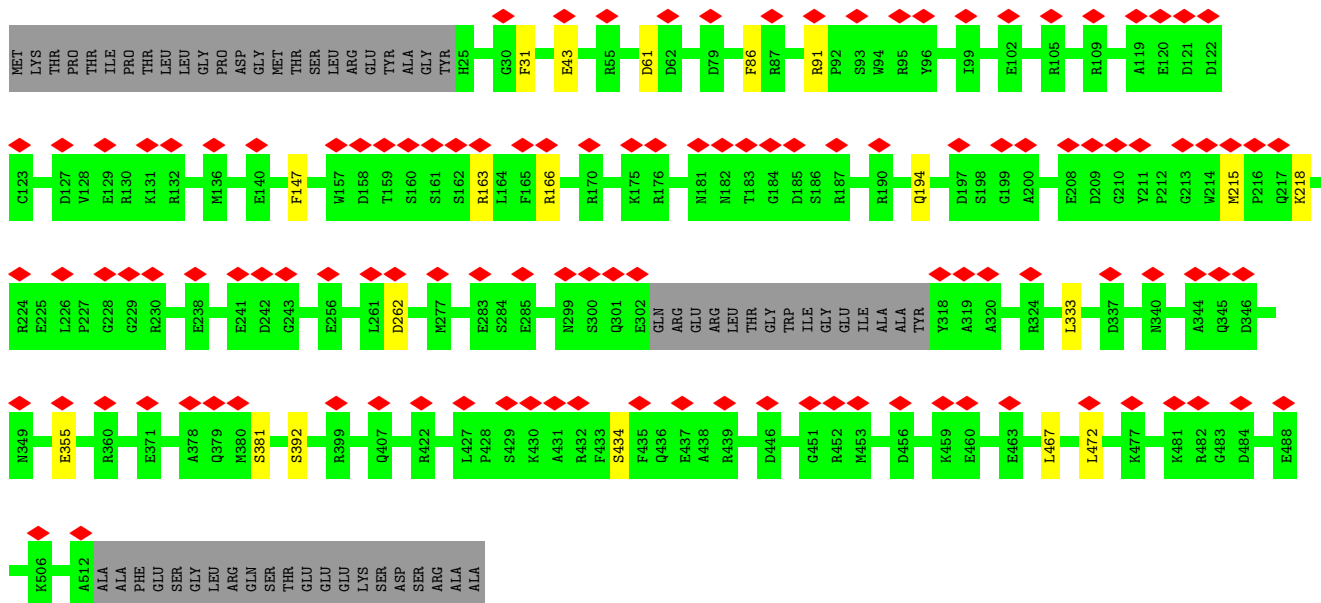

• Molecule 4: Portal protein B

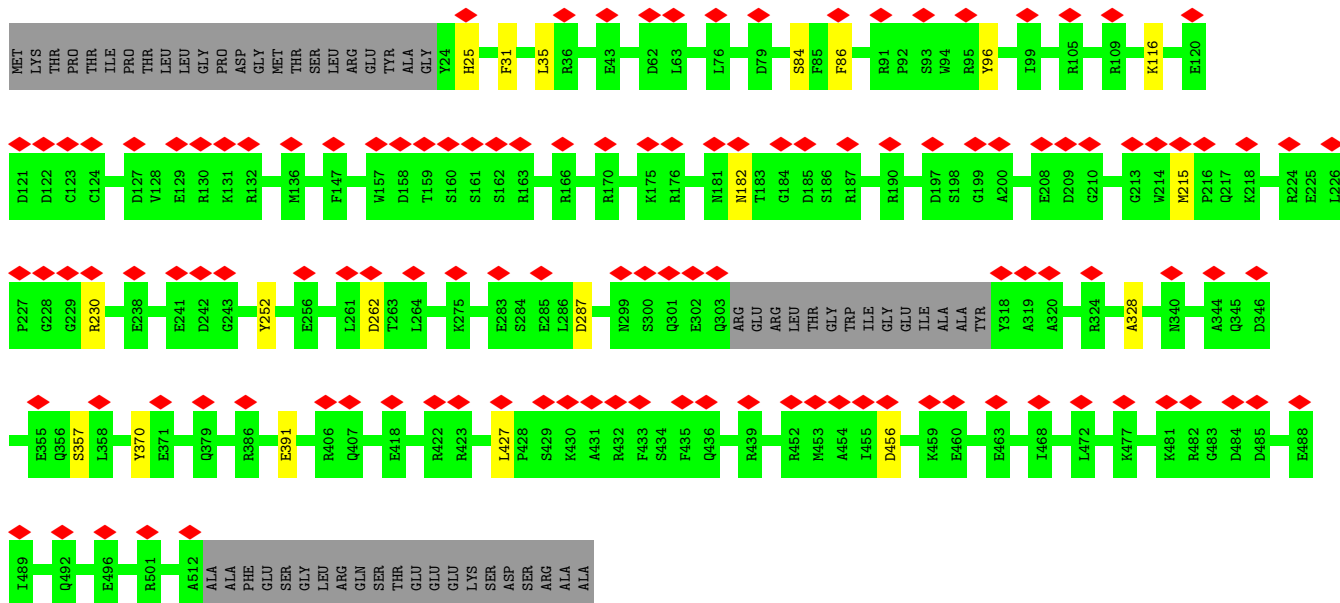
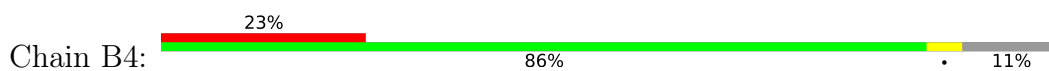

• Molecule 4: Portal protein B

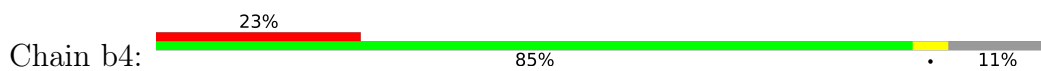

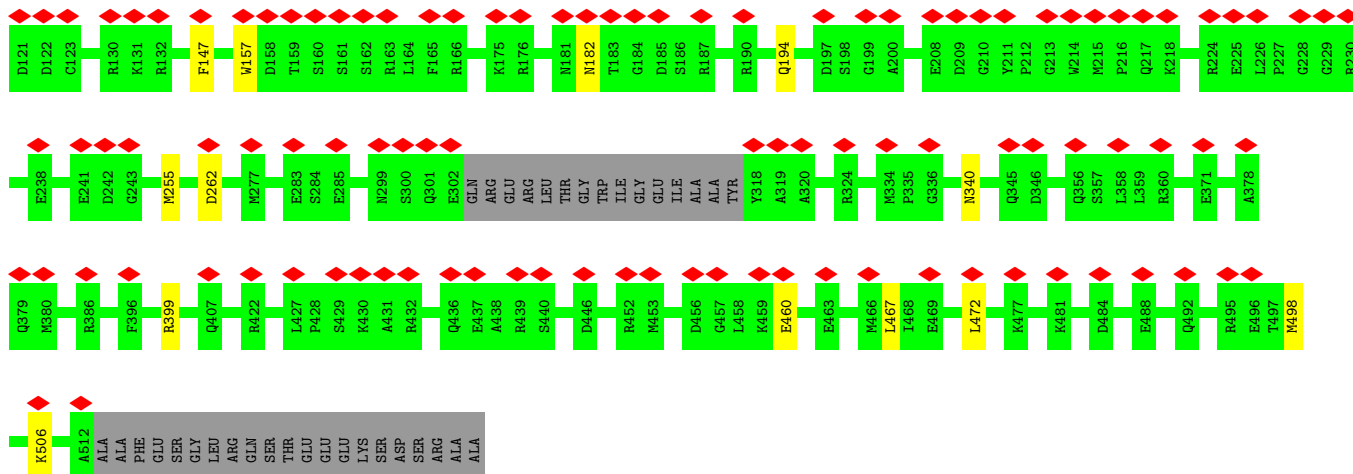

• Molecule 4: Portal protein B

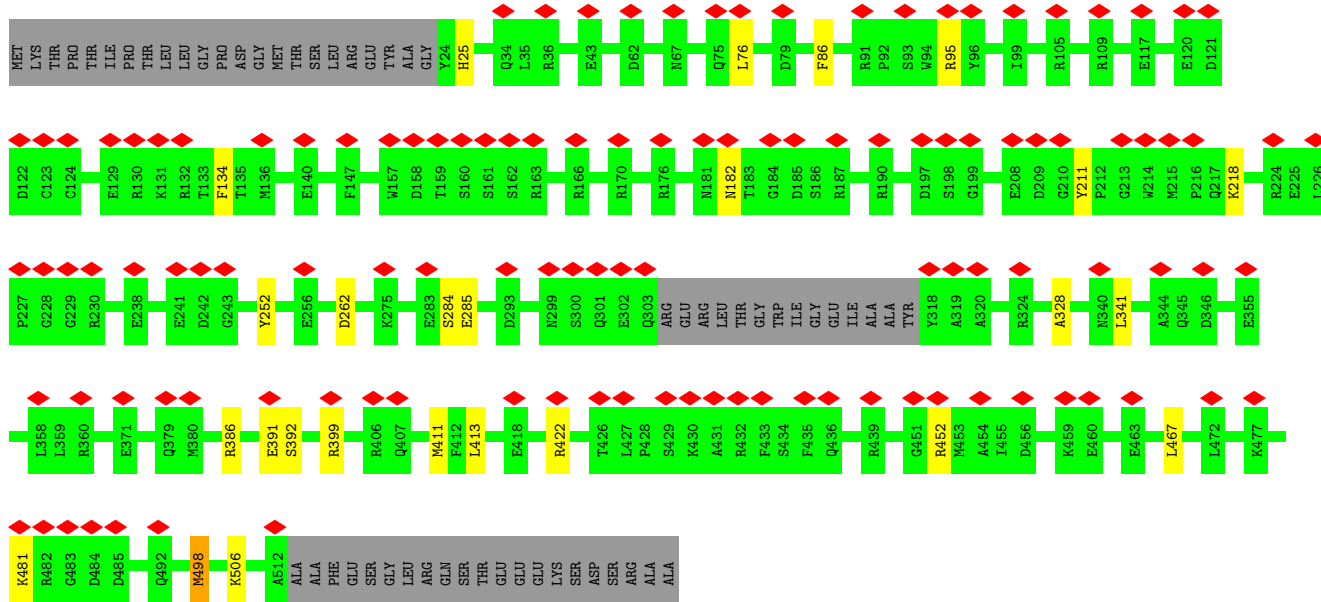
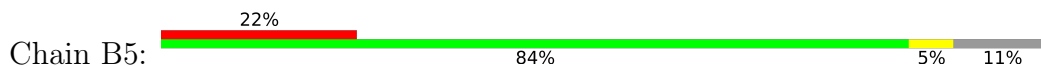

• Molecule 4: Portal protein B

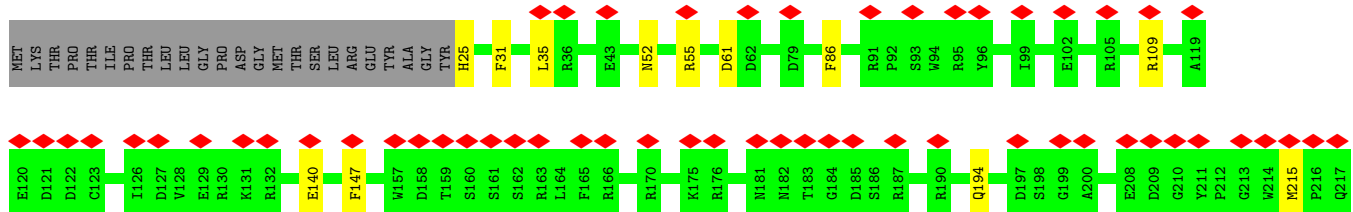
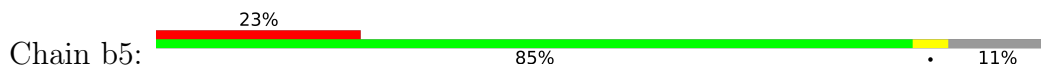



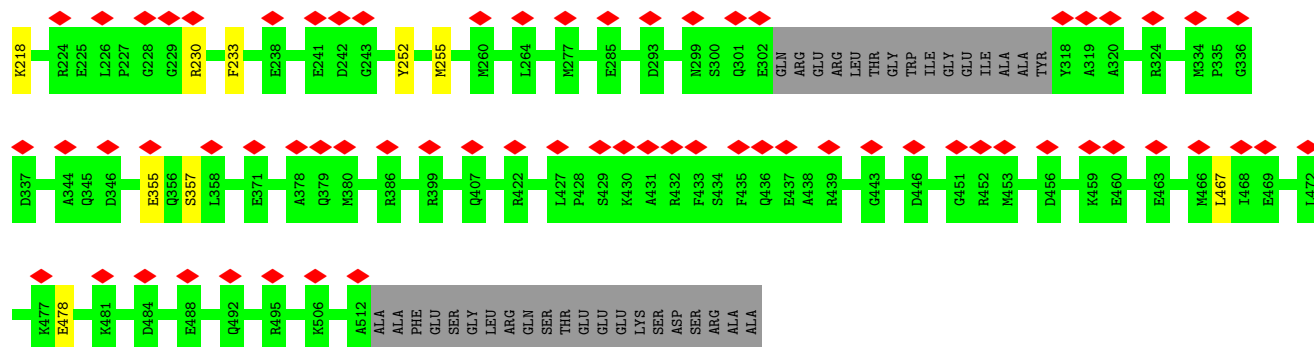

## 4 Experimental information

Property	Value	Source
EM reconstruction method	SINGLE PARTICLE	Depositor
Imposed symmetry	POINT, Not provided	
Number of particles used	19791	Depositor
Resolution determination method	FSC 0.143 CUT-OFF	Depositor
CTF correction method	NONE	Depositor
Microscope	FEI TITAN KRIOS	Depositor
Voltage (kV)	300	Depositor
Electron dose ( $e^-/\text{\AA}^2$ )	50	Depositor
Minimum defocus (nm)	1000	Depositor
Maximum defocus (nm)	2000	Depositor
Magnification	Not provided	
Image detector	GATAN K2 SUMMIT (4k x 4k)	Depositor
Maximum map value	0.850	Depositor
Minimum map value	-0.459	Depositor
Average map value	0.000	Depositor
Map value standard deviation	0.071	Depositor
Recommended contour level	0.3	Depositor
Map size ( $\text{\AA}$ )	322.26, 322.26, 322.26	wwPDB
Map dimensions	300, 300, 300	wwPDB
Map angles ( $^\circ$ )	90.0, 90.0, 90.0	wwPDB
Pixel spacing ( $\text{\AA}$ )	1.0742, 1.0742, 1.0742	Depositor

## 5 Model quality [i](#)

### 5.1 Standard geometry [i](#)

The Z score for a bond length (or angle) is the number of standard deviations the observed value is removed from the expected value. A bond length (or angle) with  $|Z| > 5$  is considered an outlier worth inspection. RMSZ is the root-mean-square of all Z scores of the bond lengths (or angles).

Mol	Chain	Bond lengths		Bond angles	
		RMSZ	# Z  >5	RMSZ	# Z  >5
1	f	0.30	0/888	0.68	1/1204 (0.1%)
1	f1	0.29	0/888	0.65	0/1204
1	f2	0.29	0/888	0.65	2/1204 (0.2%)
1	f3	0.29	0/888	0.67	1/1204 (0.1%)
1	f4	0.30	0/888	0.65	1/1204 (0.1%)
1	f5	0.28	0/888	0.60	0/1204
2	W	0.29	0/529	0.69	0/709
2	W1	0.29	0/529	0.71	0/709
2	W2	0.29	0/529	0.69	0/709
2	W3	0.31	0/529	0.74	0/709
2	W4	0.29	0/529	0.67	0/709
2	W5	0.29	0/529	0.68	0/709
2	w	0.32	0/529	0.69	0/709
2	w1	0.33	0/529	0.72	0/709
2	w2	0.31	0/529	0.69	0/709
2	w3	0.32	0/529	0.69	0/709
2	w4	0.31	0/529	0.70	0/709
2	w5	0.32	0/529	0.69	0/709
3	U	0.30	0/1058	0.62	1/1444 (0.1%)
3	U1	0.29	0/1058	0.62	1/1444 (0.1%)
3	U2	0.29	0/1058	0.64	2/1444 (0.1%)
3	U3	0.30	0/1058	0.61	1/1444 (0.1%)
3	U4	0.30	0/1058	0.59	0/1444
3	U5	0.29	0/1058	0.60	0/1444
4	B	0.29	0/3811	0.55	0/5151
4	B1	0.28	0/3811	0.55	1/5151 (0.0%)
4	B2	0.28	0/3811	0.55	1/5151 (0.0%)
4	B3	0.29	0/3811	0.57	1/5151 (0.0%)
4	B4	0.29	0/3811	0.55	1/5151 (0.0%)
4	B5	0.29	0/3811	0.57	4/5151 (0.1%)
4	b	0.29	0/3793	0.57	2/5126 (0.0%)
4	b1	0.28	0/3793	0.58	2/5126 (0.0%)
4	b2	0.28	0/3793	0.56	2/5126 (0.0%)
4	b3	0.29	0/3793	0.57	3/5126 (0.1%)

Mol	Chain	Bond lengths		Bond angles	
		RMSZ	# Z  >5	RMSZ	# Z  >5
4	b4	0.28	0/3793	0.56	1/5126 (0.0%)
4	b5	0.29	0/3793	0.57	1/5126 (0.0%)
All	All	0.29	0/63648	0.59	29/86058 (0.0%)

Chiral center outliers are detected by calculating the chiral volume of a chiral center and verifying if the center is modelled as a planar moiety or with the opposite hand. A planarity outlier is detected by checking planarity of atoms in a peptide group, atoms in a mainchain group or atoms of a sidechain that are expected to be planar.

Mol	Chain	#Chirality outliers	#Planarity outliers
2	w2	0	1
3	U	0	1
3	U1	0	1
3	U2	0	1
3	U3	0	1
3	U4	0	1
3	U5	0	1
4	B	0	1
All	All	0	8

There are no bond length outliers.

All (29) bond angle outliers are listed below:

Mol	Chain	Res	Type	Atoms	Z	Observed(°)	Ideal(°)
3	U2	72	PRO	CA-N-CD	-7.74	100.67	111.50
4	B2	76	LEU	CA-CB-CG	6.65	130.60	115.30
4	B3	76	LEU	CA-CB-CG	6.59	130.46	115.30
4	B1	76	LEU	CA-CB-CG	6.56	130.39	115.30
4	B5	76	LEU	CA-CB-CG	6.17	129.50	115.30
3	U3	72	PRO	CA-N-CD	-6.08	102.99	111.50
1	f2	81	LEU	CA-CB-CG	5.89	128.85	115.30
4	b4	262	ASP	CB-CG-OD1	5.77	123.50	118.30
3	U	72	PRO	CA-N-CD	-5.71	103.51	111.50
3	U2	39	PHE	C-N-CD	-5.70	108.06	120.60
4	b1	262	ASP	CB-CG-OD1	5.64	123.37	118.30
4	b5	61	ASP	CB-CG-OD2	5.54	123.29	118.30
4	b3	61	ASP	CB-CG-OD1	5.52	123.27	118.30
4	b	61	ASP	CB-CG-OD1	5.36	123.12	118.30
4	b3	467	LEU	CA-CB-CG	5.34	127.59	115.30
4	b	262	ASP	CB-CG-OD1	5.33	123.09	118.30
4	B4	262	ASP	CB-CG-OD1	5.32	123.09	118.30
3	U1	56	LEU	CA-CB-CG	5.25	127.38	115.30

*Continued on next page...*

Continued from previous page...

Mol	Chain	Res	Type	Atoms	Z	Observed(°)	Ideal(°)
1	f	7	LEU	CA-CB-CG	5.21	127.29	115.30
4	B5	262	ASP	CB-CG-OD1	5.18	122.96	118.30
4	b3	262	ASP	CB-CG-OD1	5.16	122.94	118.30
4	B5	498	MET	CA-CB-CG	5.11	121.99	113.30
4	b1	61	ASP	CB-CG-OD2	5.08	122.87	118.30
1	f3	81	LEU	CA-CB-CG	5.06	126.94	115.30
4	b2	209	ASP	CB-CG-OD1	5.06	122.85	118.30
1	f4	81	LEU	CA-CB-CG	5.04	126.90	115.30
4	B5	498	MET	CB-CG-SD	5.04	127.51	112.40
4	b2	61	ASP	CB-CG-OD2	5.02	122.82	118.30
1	f2	7	LEU	CA-CB-CG	5.00	126.81	115.30

There are no chirality outliers.

All (8) planarity outliers are listed below:

Mol	Chain	Res	Type	Group
4	B	349	ASN	Peptide
3	U	39	PHE	Peptide
3	U1	39	PHE	Peptide
3	U2	39	PHE	Peptide
3	U3	39	PHE	Peptide
3	U4	39	PHE	Peptide
3	U5	39	PHE	Peptide
2	w2	20	GLY	Peptide

## 5.2 Too-close contacts [i](#)

Due to software issues we are unable to calculate clashes - this section is therefore empty.

## 5.3 Torsion angles [i](#)

### 5.3.1 Protein backbone [i](#)

In the following table, the Percentiles column shows the percent Ramachandran outliers of the chain as a percentile score with respect to all PDB entries followed by that with respect to all EM entries.

The Analysed column shows the number of residues for which the backbone conformation was analysed, and the total number of residues.

Mol	Chain	Analysed	Favoured	Allowed	Outliers	Percentiles	
1	f	112/117 (96%)	92 (82%)	20 (18%)	0	100	100
1	f1	112/117 (96%)	89 (80%)	23 (20%)	0	100	100
1	f2	112/117 (96%)	92 (82%)	20 (18%)	0	100	100
1	f3	112/117 (96%)	92 (82%)	20 (18%)	0	100	100
1	f4	112/117 (96%)	92 (82%)	20 (18%)	0	100	100
1	f5	112/117 (96%)	89 (80%)	23 (20%)	0	100	100
2	W	65/68 (96%)	60 (92%)	5 (8%)	0	100	100
2	W1	65/68 (96%)	59 (91%)	6 (9%)	0	100	100
2	W2	65/68 (96%)	60 (92%)	4 (6%)	1 (2%)	10	38
2	W3	65/68 (96%)	59 (91%)	5 (8%)	1 (2%)	10	38
2	W4	65/68 (96%)	60 (92%)	5 (8%)	0	100	100
2	W5	65/68 (96%)	60 (92%)	4 (6%)	1 (2%)	10	38
2	w	65/68 (96%)	57 (88%)	7 (11%)	1 (2%)	10	38
2	w1	65/68 (96%)	58 (89%)	6 (9%)	1 (2%)	10	38
2	w2	65/68 (96%)	56 (86%)	8 (12%)	1 (2%)	10	38
2	w3	65/68 (96%)	59 (91%)	5 (8%)	1 (2%)	10	38
2	w4	65/68 (96%)	58 (89%)	6 (9%)	1 (2%)	10	38
2	w5	65/68 (96%)	60 (92%)	4 (6%)	1 (2%)	10	38
3	U	129/131 (98%)	104 (81%)	20 (16%)	5 (4%)	3	20
3	U1	129/131 (98%)	105 (81%)	20 (16%)	4 (3%)	4	24
3	U2	129/131 (98%)	103 (80%)	23 (18%)	3 (2%)	6	30
3	U3	129/131 (98%)	106 (82%)	19 (15%)	4 (3%)	4	24
3	U4	129/131 (98%)	104 (81%)	21 (16%)	4 (3%)	4	24
3	U5	129/131 (98%)	106 (82%)	19 (15%)	4 (3%)	4	24
4	B	471/533 (88%)	434 (92%)	37 (8%)	0	100	100
4	B1	471/533 (88%)	442 (94%)	29 (6%)	0	100	100
4	B2	471/533 (88%)	437 (93%)	33 (7%)	1 (0%)	47	76
4	B3	471/533 (88%)	439 (93%)	31 (7%)	1 (0%)	47	76
4	B4	471/533 (88%)	437 (93%)	33 (7%)	1 (0%)	47	76
4	B5	471/533 (88%)	439 (93%)	31 (7%)	1 (0%)	47	76
4	b	469/533 (88%)	441 (94%)	27 (6%)	1 (0%)	47	76
4	b1	469/533 (88%)	436 (93%)	33 (7%)	0	100	100

Continued on next page...

*Continued from previous page...*

Mol	Chain	Analysed	Favoured	Allowed	Outliers	Percentiles	
4	b2	469/533 (88%)	440 (94%)	29 (6%)	0	100	100
4	b3	469/533 (88%)	440 (94%)	29 (6%)	0	100	100
4	b4	469/533 (88%)	444 (95%)	25 (5%)	0	100	100
4	b5	469/533 (88%)	449 (96%)	20 (4%)	0	100	100
All	All	7866/8700 (90%)	7158 (91%)	670 (8%)	38 (0%)	32	61

All (38) Ramachandran outliers are listed below:

Mol	Chain	Res	Type
2	w	63	PRO
3	U	30	ARG
4	b	320	ALA
2	w1	63	PRO
2	W2	63	PRO
2	w2	63	PRO
2	W3	63	PRO
2	w3	63	PRO
2	w4	63	PRO
2	W5	63	PRO
2	w5	63	PRO
3	U5	30	ARG
3	U2	30	ARG
3	U2	33	VAL
3	U3	30	ARG
3	U1	118	ALA
3	U2	39	PHE
4	B3	328	ALA
3	U4	30	ARG
4	B4	328	ALA
4	B5	328	ALA
3	U3	39	PHE
3	U3	40	PRO
3	U5	40	PRO
3	U	33	VAL
3	U	39	PHE
3	U1	33	VAL
3	U1	39	PHE
3	U1	40	PRO
3	U3	33	VAL
3	U4	33	VAL
3	U4	39	PHE

*Continued on next page...*

*Continued from previous page...*

Mol	Chain	Res	Type
3	U5	33	VAL
3	U5	39	PHE
3	U	73	ALA
4	B2	328	ALA
3	U	40	PRO
3	U4	40	PRO

### 5.3.2 Protein sidechains [i](#)

In the following table, the Percentiles column shows the percent sidechain outliers of the chain as a percentile score with respect to all PDB entries followed by that with respect to all EM entries.

The Analysed column shows the number of residues for which the sidechain conformation was analysed, and the total number of residues.

Mol	Chain	Analysed	Rotameric	Outliers	Percentiles	
1	f	91/94 (97%)	85 (93%)	6 (7%)	16	47
1	f1	91/94 (97%)	85 (93%)	6 (7%)	16	47
1	f2	91/94 (97%)	88 (97%)	3 (3%)	38	67
1	f3	91/94 (97%)	83 (91%)	8 (9%)	10	34
1	f4	91/94 (97%)	84 (92%)	7 (8%)	13	40
1	f5	91/94 (97%)	84 (92%)	7 (8%)	13	40
2	W	53/54 (98%)	50 (94%)	3 (6%)	20	52
2	W1	53/54 (98%)	49 (92%)	4 (8%)	13	41
2	W2	53/54 (98%)	46 (87%)	7 (13%)	4	17
2	W3	53/54 (98%)	49 (92%)	4 (8%)	13	41
2	W4	53/54 (98%)	50 (94%)	3 (6%)	20	52
2	W5	53/54 (98%)	46 (87%)	7 (13%)	4	17
2	w	53/54 (98%)	51 (96%)	2 (4%)	33	63
2	w1	53/54 (98%)	46 (87%)	7 (13%)	4	17
2	w2	53/54 (98%)	48 (91%)	5 (9%)	8	31
2	w3	53/54 (98%)	47 (89%)	6 (11%)	6	23
2	w4	53/54 (98%)	52 (98%)	1 (2%)	57	78
2	w5	53/54 (98%)	46 (87%)	7 (13%)	4	17
3	U	109/109 (100%)	101 (93%)	8 (7%)	14	42

*Continued on next page...*



Continued from previous page...

Mol	Chain	Analysed	Rotameric	Outliers	Percentiles	
3	U1	109/109 (100%)	101 (93%)	8 (7%)	14	42
3	U2	109/109 (100%)	99 (91%)	10 (9%)	9	32
3	U3	109/109 (100%)	99 (91%)	10 (9%)	9	32
3	U4	109/109 (100%)	97 (89%)	12 (11%)	6	24
3	U5	109/109 (100%)	100 (92%)	9 (8%)	11	37
4	B	381/428 (89%)	361 (95%)	20 (5%)	23	55
4	B1	381/428 (89%)	367 (96%)	14 (4%)	34	64
4	B2	381/428 (89%)	369 (97%)	12 (3%)	40	68
4	B3	381/428 (89%)	365 (96%)	16 (4%)	30	61
4	B4	381/428 (89%)	364 (96%)	17 (4%)	27	60
4	B5	381/428 (89%)	358 (94%)	23 (6%)	19	50
4	b	380/428 (89%)	365 (96%)	15 (4%)	32	63
4	b1	380/428 (89%)	363 (96%)	17 (4%)	27	60
4	b2	380/428 (89%)	361 (95%)	19 (5%)	24	56
4	b3	380/428 (89%)	364 (96%)	16 (4%)	30	61
4	b4	380/428 (89%)	362 (95%)	18 (5%)	26	59
4	b5	380/428 (89%)	360 (95%)	20 (5%)	22	54
All	All	6402/7002 (91%)	6045 (94%)	357 (6%)	25	53

All (357) residues with a non-rotameric sidechain are listed below:

Mol	Chain	Res	Type
1	f	4	PHE
1	f	9	ASP
1	f	26	SER
1	f	33	GLU
1	f	97	ASP
1	f	107	ARG
2	W	50	LEU
2	W	53	GLN
2	W	66	PHE
2	w	22	ARG
2	w	53	GLN
3	U	19	LYS
3	U	28	ASP
3	U	30	ARG

Continued on next page...

*Continued from previous page...*

<b>Mol</b>	<b>Chain</b>	<b>Res</b>	<b>Type</b>
3	U	56	LEU
3	U	87	ARG
3	U	92	MET
3	U	108	SER
3	U	110	TYR
4	B	25	HIS
4	B	35	LEU
4	B	66	ASN
4	B	95	ARG
4	B	116	LYS
4	B	125	CYS
4	B	144	MET
4	B	166	ARG
4	B	182	ASN
4	B	215	MET
4	B	218	LYS
4	B	241	GLU
4	B	252	TYR
4	B	287	ASP
4	B	293	ASP
4	B	379	GLN
4	B	391	GLU
4	B	433	PHE
4	B	498	MET
4	B	506	LYS
4	b	31	PHE
4	b	42	SER
4	b	44	SER
4	b	86	PHE
4	b	147	PHE
4	b	157	TRP
4	b	182	ASN
4	b	215	MET
4	b	218	LYS
4	b	244	GLN
4	b	252	TYR
4	b	338	SER
4	b	417	GLU
4	b	463	GLU
4	b	505	LEU
1	f1	4	PHE
1	f1	9	ASP

*Continued on next page...*

*Continued from previous page...*

<b>Mol</b>	<b>Chain</b>	<b>Res</b>	<b>Type</b>
1	f1	45	ASP
1	f1	77	ARG
1	f1	107	ARG
1	f1	116	ARG
2	W1	16	ASP
2	W1	41	SER
2	W1	53	GLN
2	W1	59	ARG
2	w1	16	ASP
2	w1	45	LYS
2	w1	51	GLU
2	w1	53	GLN
2	w1	58	GLN
2	w1	61	ARG
2	w1	67	TYR
3	U1	27	PHE
3	U1	38	ASP
3	U1	39	PHE
3	U1	84	MET
3	U1	92	MET
3	U1	110	TYR
3	U1	123	SER
3	U1	132	TYR
4	B1	25	HIS
4	B1	35	LEU
4	B1	76	LEU
4	B1	86	PHE
4	B1	136	MET
4	B1	144	MET
4	B1	181	ASN
4	B1	182	ASN
4	B1	241	GLU
4	B1	252	TYR
4	B1	257	GLN
4	B1	369	SER
4	B1	391	GLU
4	B1	477	LYS
4	b1	31	PHE
4	b1	52	ASN
4	b1	144	MET
4	b1	147	PHE
4	b1	186	SER

*Continued on next page...*

*Continued from previous page...*

<b>Mol</b>	<b>Chain</b>	<b>Res</b>	<b>Type</b>
4	b1	194	GLN
4	b1	215	MET
4	b1	218	LYS
4	b1	233	PHE
4	b1	252	TYR
4	b1	345	GLN
4	b1	356	GLN
4	b1	357	SER
4	b1	423	ARG
4	b1	434	SER
4	b1	501	ARG
4	b1	505	LEU
1	f2	4	PHE
1	f2	77	ARG
1	f2	107	ARG
2	W2	5	GLU
2	W2	16	ASP
2	W2	41	SER
2	W2	42	ASP
2	W2	50	LEU
2	W2	53	GLN
2	W2	58	GLN
2	w2	21	LYS
2	w2	22	ARG
2	w2	39	SER
2	w2	42	ASP
2	w2	56	MET
3	U2	9	LEU
3	U2	19	LYS
3	U2	20	HIS
3	U2	30	ARG
3	U2	39	PHE
3	U2	62	GLN
3	U2	105	MET
3	U2	113	ARG
3	U2	114	ARG
3	U2	123	SER
4	B2	25	HIS
4	B2	29	SER
4	B2	35	LEU
4	B2	76	LEU
4	B2	86	PHE

*Continued on next page...*

*Continued from previous page...*

<b>Mol</b>	<b>Chain</b>	<b>Res</b>	<b>Type</b>
4	B2	136	MET
4	B2	144	MET
4	B2	166	ARG
4	B2	182	ASN
4	B2	355	GLU
4	B2	411	MET
4	B2	467	LEU
4	b2	25	HIS
4	b2	31	PHE
4	b2	35	LEU
4	b2	39	ASN
4	b2	49	LEU
4	b2	86	PHE
4	b2	95	ARG
4	b2	109	ARG
4	b2	132	ARG
4	b2	215	MET
4	b2	218	LYS
4	b2	235	HIS
4	b2	255	MET
4	b2	333	LEU
4	b2	345	GLN
4	b2	352	SER
4	b2	354	PHE
4	b2	498	MET
4	b2	505	LEU
1	f3	4	PHE
1	f3	6	ASN
1	f3	26	SER
1	f3	77	ARG
1	f3	85	GLU
1	f3	87	ASN
1	f3	107	ARG
1	f3	116	ARG
2	W3	32	ARG
2	W3	39	SER
2	W3	49	GLU
2	W3	59	ARG
2	w3	22	ARG
2	w3	32	ARG
2	w3	39	SER
2	w3	42	ASP

*Continued on next page...*

*Continued from previous page...*

<b>Mol</b>	<b>Chain</b>	<b>Res</b>	<b>Type</b>
2	w3	49	GLU
2	w3	58	GLN
3	U3	9	LEU
3	U3	19	LYS
3	U3	28	ASP
3	U3	39	PHE
3	U3	62	GLN
3	U3	110	TYR
3	U3	113	ARG
3	U3	123	SER
3	U3	132	TYR
3	U3	134	MET
4	B3	35	LEU
4	B3	37	SER
4	B3	44	SER
4	B3	55	ARG
4	B3	76	LEU
4	B3	151	LEU
4	B3	182	ASN
4	B3	233	PHE
4	B3	252	TYR
4	B3	262	ASP
4	B3	357	SER
4	B3	391	GLU
4	B3	413	LEU
4	B3	456	ASP
4	B3	459	LYS
4	B3	498	MET
4	b3	31	PHE
4	b3	43	GLU
4	b3	86	PHE
4	b3	91	ARG
4	b3	147	PHE
4	b3	163	ARG
4	b3	166	ARG
4	b3	194	GLN
4	b3	215	MET
4	b3	218	LYS
4	b3	333	LEU
4	b3	355	GLU
4	b3	381	SER
4	b3	392	SER

*Continued on next page...*

*Continued from previous page...*

<b>Mol</b>	<b>Chain</b>	<b>Res</b>	<b>Type</b>
4	b3	434	SER
4	b3	472	LEU
1	f4	4	PHE
1	f4	22	TYR
1	f4	33	GLU
1	f4	45	ASP
1	f4	77	ARG
1	f4	102	HIS
1	f4	107	ARG
2	W4	32	ARG
2	W4	51	GLU
2	W4	53	GLN
2	w4	32	ARG
3	U4	19	LYS
3	U4	27	PHE
3	U4	38	ASP
3	U4	39	PHE
3	U4	52	THR
3	U4	62	GLN
3	U4	87	ARG
3	U4	92	MET
3	U4	94	ASP
3	U4	110	TYR
3	U4	132	TYR
3	U4	134	MET
4	B4	25	HIS
4	B4	31	PHE
4	B4	35	LEU
4	B4	84	SER
4	B4	86	PHE
4	B4	96	TYR
4	B4	116	LYS
4	B4	182	ASN
4	B4	215	MET
4	B4	230	ARG
4	B4	252	TYR
4	B4	287	ASP
4	B4	357	SER
4	B4	370	TYR
4	B4	391	GLU
4	B4	427	LEU
4	B4	456	ASP

*Continued on next page...*

*Continued from previous page...*

<b>Mol</b>	<b>Chain</b>	<b>Res</b>	<b>Type</b>
4	b4	25	HIS
4	b4	31	PHE
4	b4	35	LEU
4	b4	86	PHE
4	b4	91	ARG
4	b4	109	ARG
4	b4	147	PHE
4	b4	157	TRP
4	b4	182	ASN
4	b4	194	GLN
4	b4	255	MET
4	b4	340	ASN
4	b4	399	ARG
4	b4	460	GLU
4	b4	467	LEU
4	b4	472	LEU
4	b4	498	MET
4	b4	506	LYS
1	f5	4	PHE
1	f5	6	ASN
1	f5	9	ASP
1	f5	43	PHE
1	f5	87	ASN
1	f5	107	ARG
1	f5	116	ARG
2	W5	16	ASP
2	W5	39	SER
2	W5	42	ASP
2	W5	53	GLN
2	W5	56	MET
2	W5	57	THR
2	W5	61	ARG
2	w5	11	ARG
2	w5	21	LYS
2	w5	22	ARG
2	w5	29	ASP
2	w5	39	SER
2	w5	42	ASP
2	w5	58	GLN
3	U5	19	LYS
3	U5	38	ASP
3	U5	39	PHE

*Continued on next page...*



*Continued from previous page...*

<b>Mol</b>	<b>Chain</b>	<b>Res</b>	<b>Type</b>
3	U5	62	GLN
3	U5	84	MET
3	U5	92	MET
3	U5	105	MET
3	U5	110	TYR
3	U5	116	ASP
4	B5	25	HIS
4	B5	86	PHE
4	B5	95	ARG
4	B5	134	PHE
4	B5	182	ASN
4	B5	211	TYR
4	B5	218	LYS
4	B5	252	TYR
4	B5	284	SER
4	B5	285	GLU
4	B5	341	LEU
4	B5	386	ARG
4	B5	391	GLU
4	B5	392	SER
4	B5	399	ARG
4	B5	411	MET
4	B5	413	LEU
4	B5	422	ARG
4	B5	452	ARG
4	B5	467	LEU
4	B5	481	LYS
4	B5	498	MET
4	B5	506	LYS
4	b5	25	HIS
4	b5	31	PHE
4	b5	35	LEU
4	b5	52	ASN
4	b5	55	ARG
4	b5	86	PHE
4	b5	109	ARG
4	b5	140	GLU
4	b5	147	PHE
4	b5	194	GLN
4	b5	215	MET
4	b5	218	LYS
4	b5	230	ARG

*Continued on next page...*

*Continued from previous page...*

Mol	Chain	Res	Type
4	b5	233	PHE
4	b5	252	TYR
4	b5	255	MET
4	b5	355	GLU
4	b5	357	SER
4	b5	467	LEU
4	b5	478	GLU

Sometimes sidechains can be flipped to improve hydrogen bonding and reduce clashes. All (30) such sidechains are listed below:

Mol	Chain	Res	Type
4	B	66	ASN
4	B	145	HIS
4	b	299	ASN
1	f1	54	GLN
2	W1	58	GLN
2	w1	53	GLN
4	B1	345	GLN
4	B1	349	ASN
4	b1	34	GLN
1	f2	114	ASN
4	B2	148	ASN
4	B2	270	GLN
4	B2	345	GLN
4	B2	349	ASN
4	b2	266	ASN
2	W3	4	GLN
2	W3	58	GLN
4	B3	257	GLN
4	B3	345	GLN
4	B3	349	ASN
4	b3	66	ASN
4	b3	266	ASN
4	B4	257	GLN
4	B4	270	GLN
4	b4	342	GLN
4	B5	265	GLN
4	B5	345	GLN
4	B5	349	ASN
4	b5	299	ASN
4	b5	301	GLN

### 5.3.3 RNA [i](#)

There are no RNA molecules in this entry.

### 5.4 Non-standard residues in protein, DNA, RNA chains [i](#)

There are no non-standard protein/DNA/RNA residues in this entry.

### 5.5 Carbohydrates [i](#)

There are no monosaccharides in this entry.

### 5.6 Ligand geometry [i](#)

There are no ligands in this entry.

### 5.7 Other polymers [i](#)

There are no such residues in this entry.

### 5.8 Polymer linkage issues [i](#)

There are no chain breaks in this entry.

## 6 Map visualisation [i](#)

This section contains visualisations of the EMDB entry EMD-38542. These allow visual inspection of the internal detail of the map and identification of artifacts.

Images derived from a raw map, generated by summing the deposited half-maps, are presented below the corresponding image components of the primary map to allow further visual inspection and comparison with those of the primary map.

### 6.1 Orthogonal projections [i](#)

#### 6.1.1 Primary map

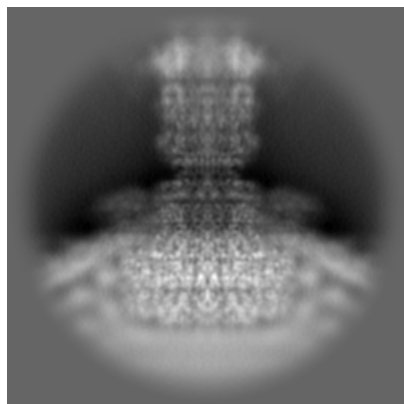

X

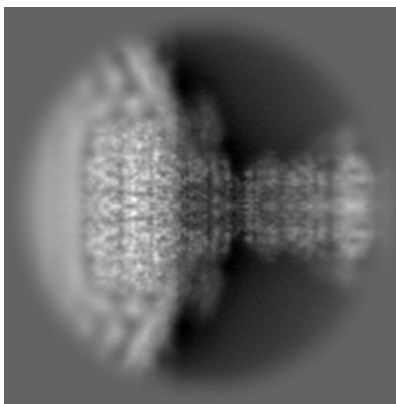

Y

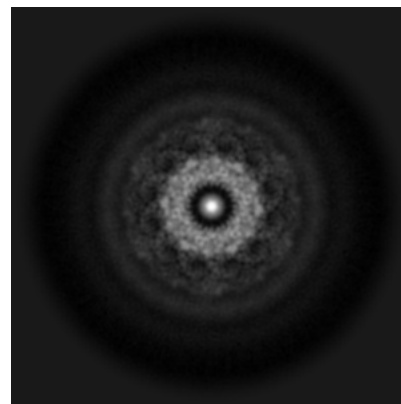

Z

#### 6.1.2 Raw map

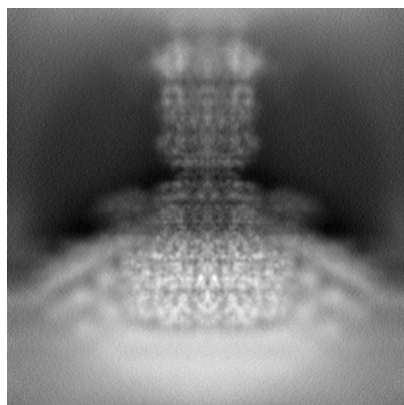

X

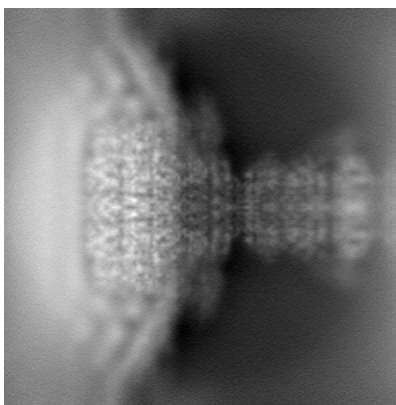

Y

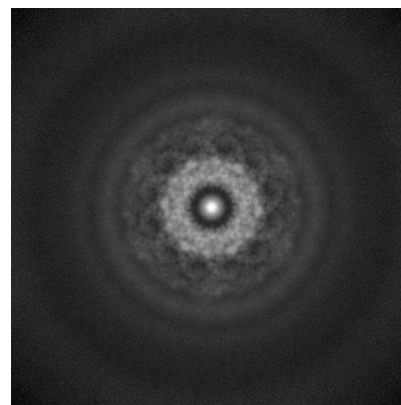

Z

The images above show the map projected in three orthogonal directions.

## 6.2 Central slices [i](#)

### 6.2.1 Primary map

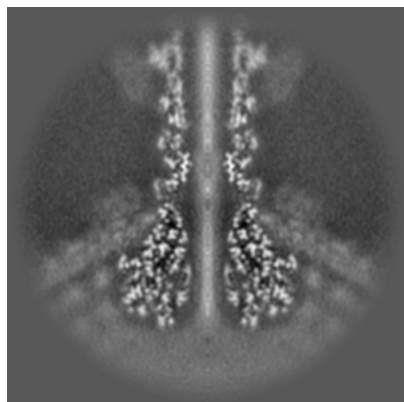

X Index: 150

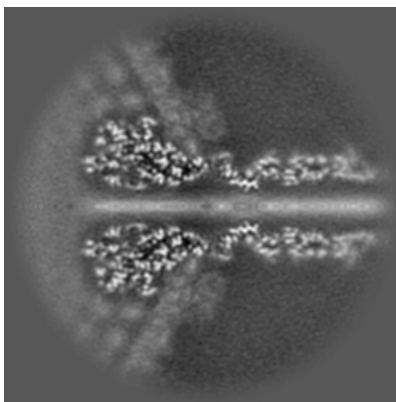

Y Index: 150

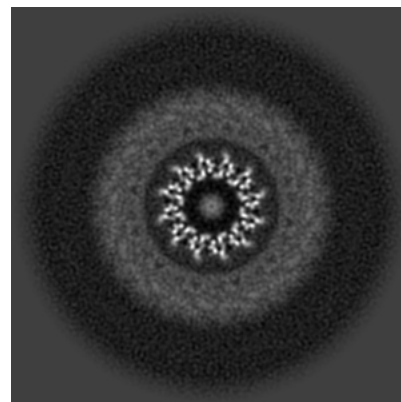

Z Index: 150

### 6.2.2 Raw map

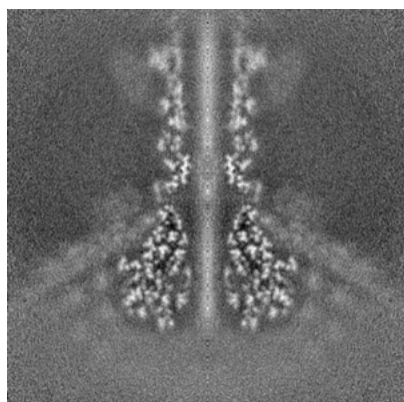

X Index: 150

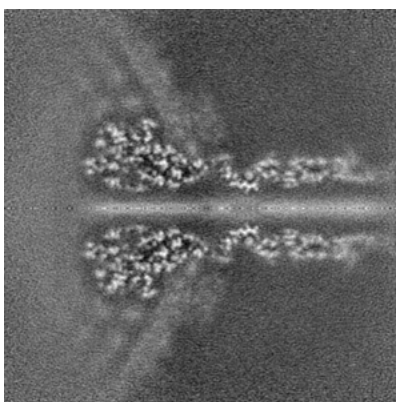

Y Index: 150

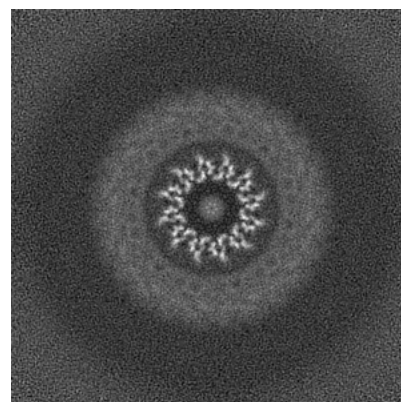

Z Index: 150

The images above show central slices of the map in three orthogonal directions.

## 6.3 Largest variance slices [i](#)

### 6.3.1 Primary map

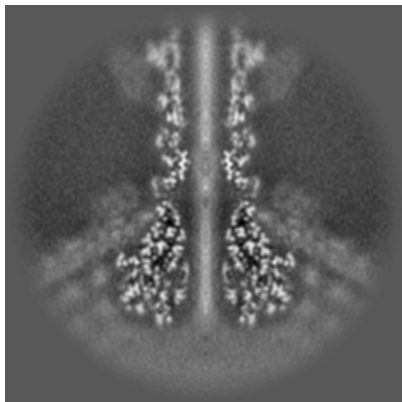

X Index: 150

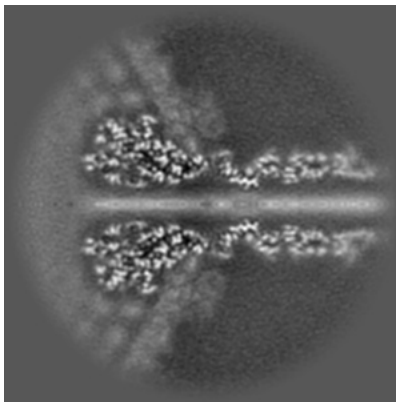

Y Index: 150

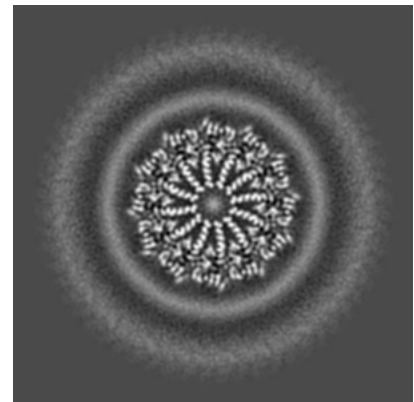

Z Index: 96

### 6.3.2 Raw map

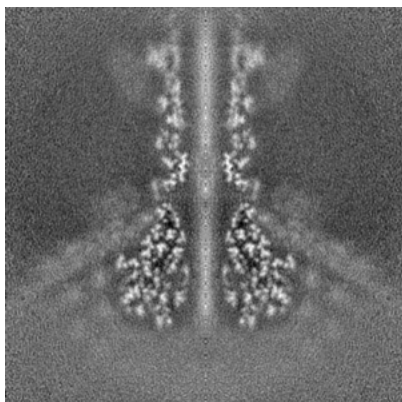

X Index: 150

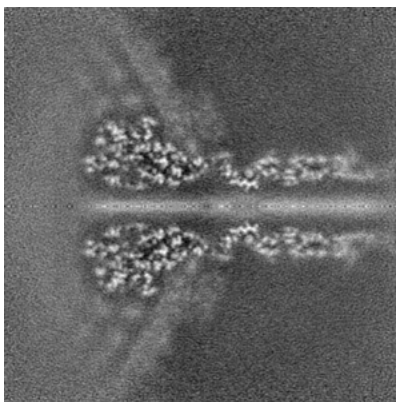

Y Index: 150

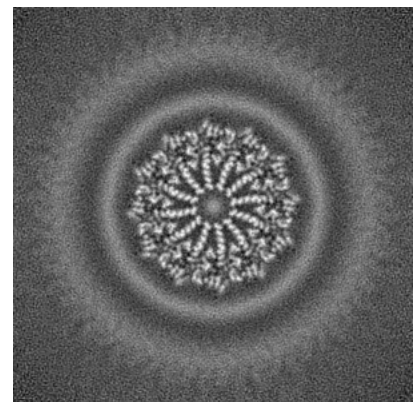

Z Index: 96

The images above show the largest variance slices of the map in three orthogonal directions.

## 6.4 Orthogonal standard-deviation projections (False-color) [i](#)

### 6.4.1 Primary map

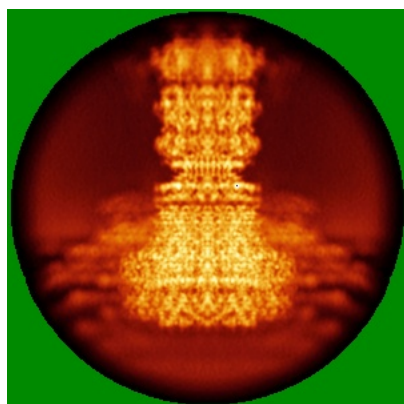

X

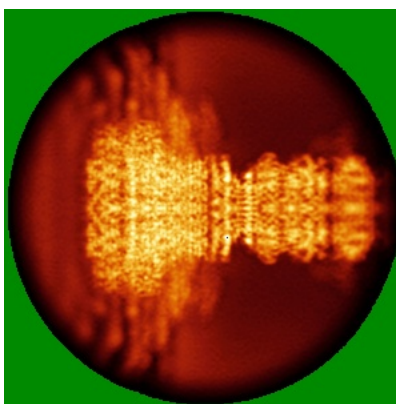

Y

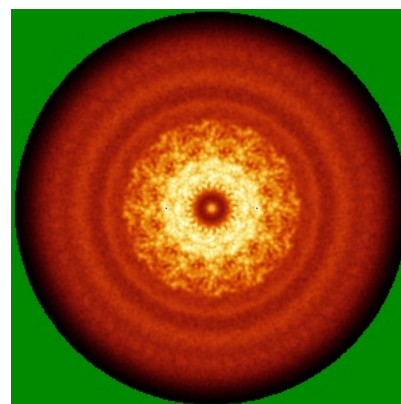

Z

### 6.4.2 Raw map

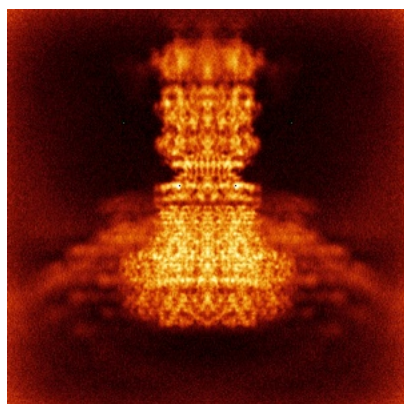

X

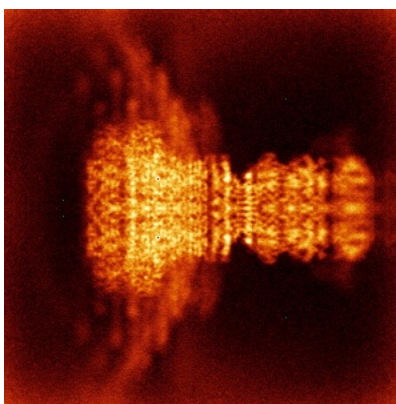

Y

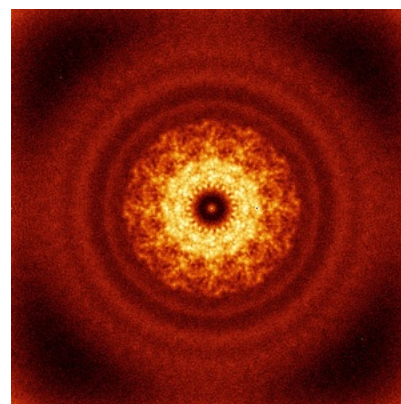

Z

The images above show the map standard deviation projections with false color in three orthogonal directions. Minimum values are shown in green, max in blue, and dark to light orange shades represent small to large values respectively.

## 6.5 Orthogonal surface views [i](#)

### 6.5.1 Primary map

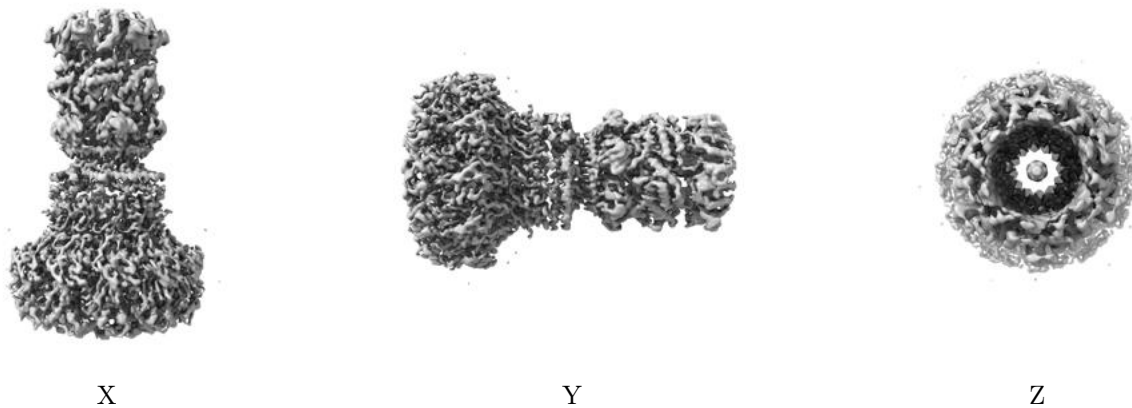

The images above show the 3D surface view of the map at the recommended contour level 0.3. These images, in conjunction with the slice images, may facilitate assessment of whether an appropriate contour level has been provided.

### 6.5.2 Raw map

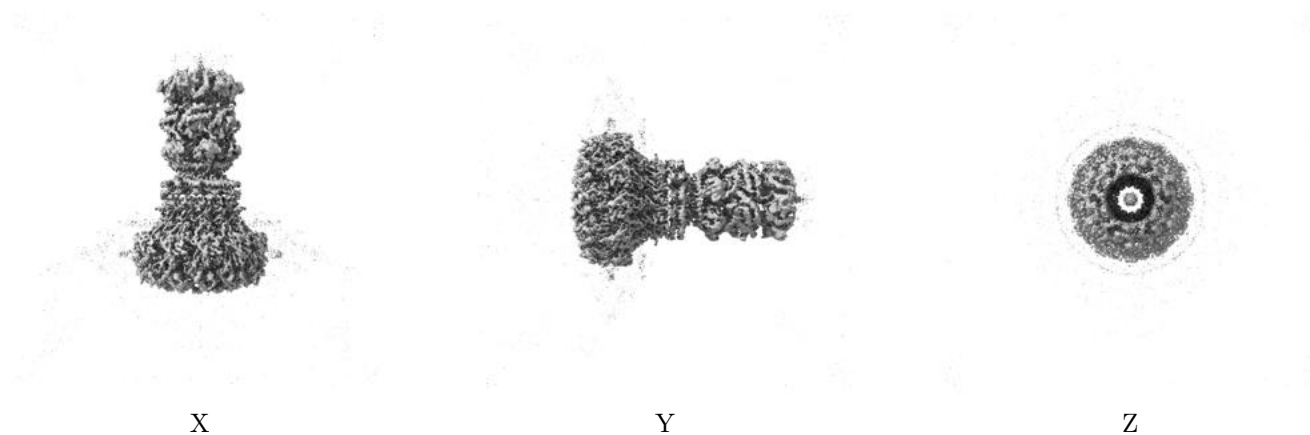

These images show the 3D surface of the raw map. The raw map's contour level was selected so that its surface encloses the same volume as the primary map does at its recommended contour level.

## 6.6 Mask visualisation [i](#)

This section was not generated. No masks/segmentation were deposited.



## 7 Map analysis [i](#)

This section contains the results of statistical analysis of the map.

### 7.1 Map-value distribution [i](#)

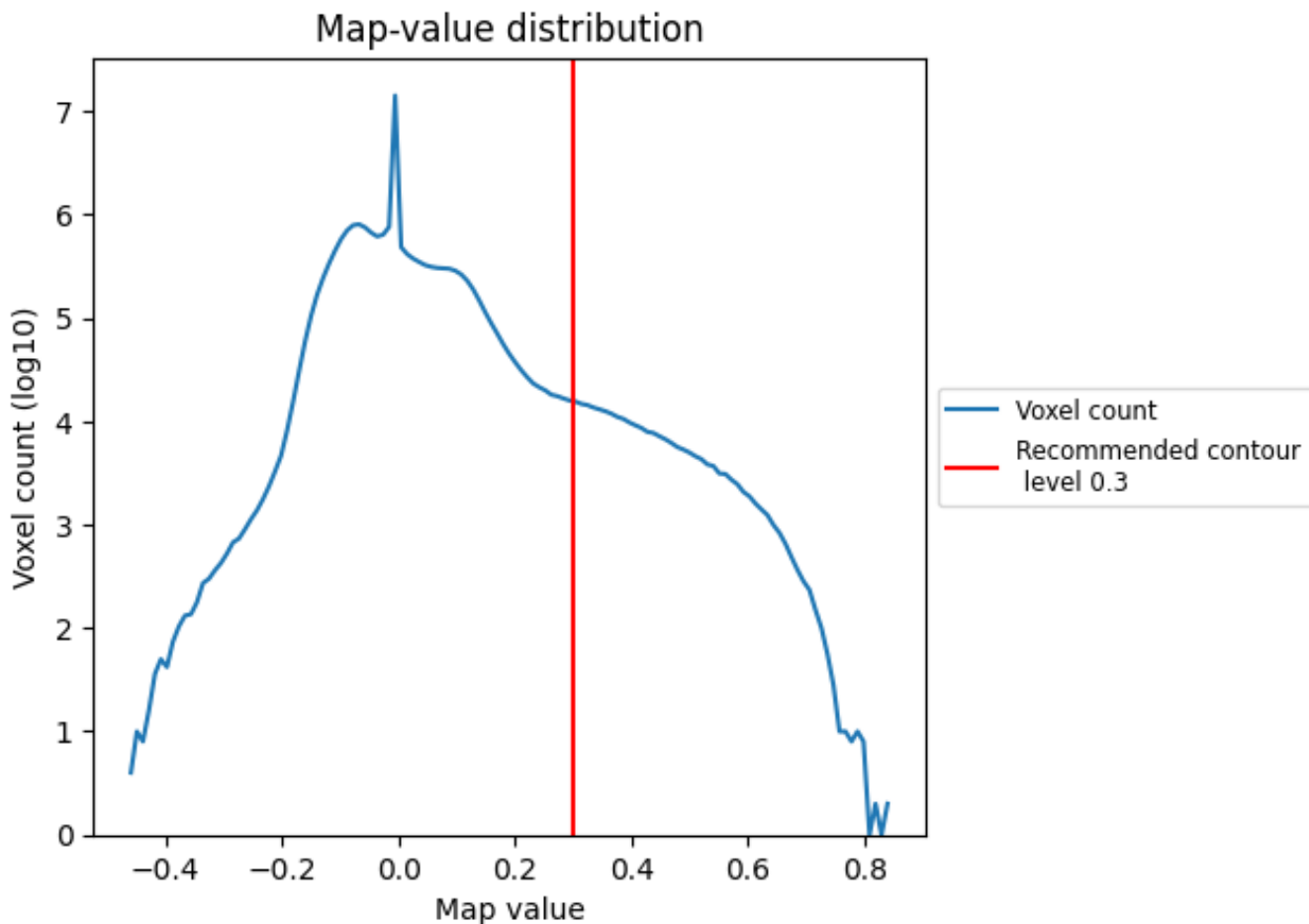

The map-value distribution is plotted in 128 intervals along the x-axis. The y-axis is logarithmic. A spike in this graph at zero usually indicates that the volume has been masked.

## 7.2 Volume estimate [i](#)

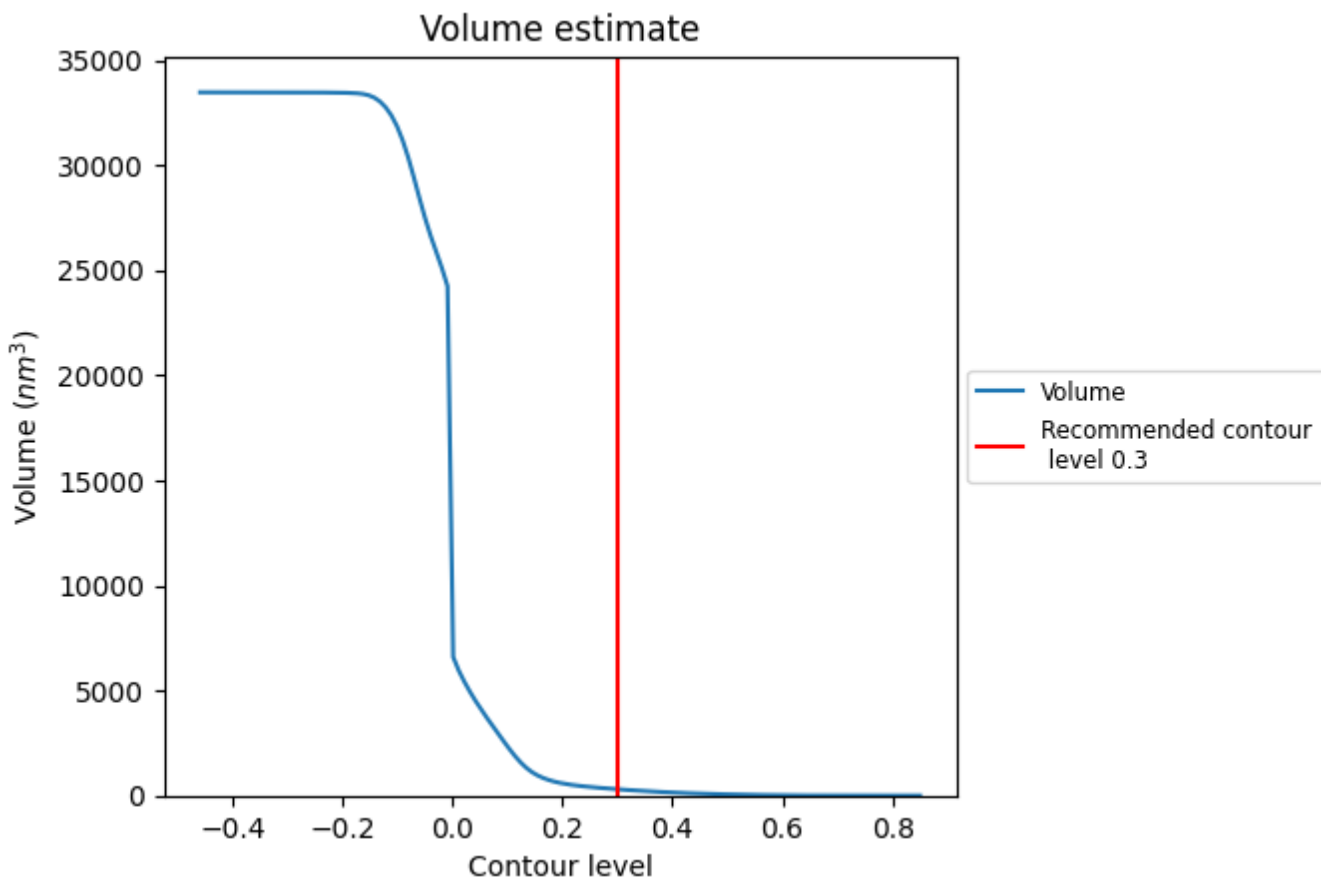

The volume at the recommended contour level is 301 nm<sup>3</sup>; this corresponds to an approximate mass of 272 kDa.

The volume estimate graph shows how the enclosed volume varies with the contour level. The recommended contour level is shown as a vertical line and the intersection between the line and the curve gives the volume of the enclosed surface at the given level.

### 7.3 Rotationally averaged power spectrum i

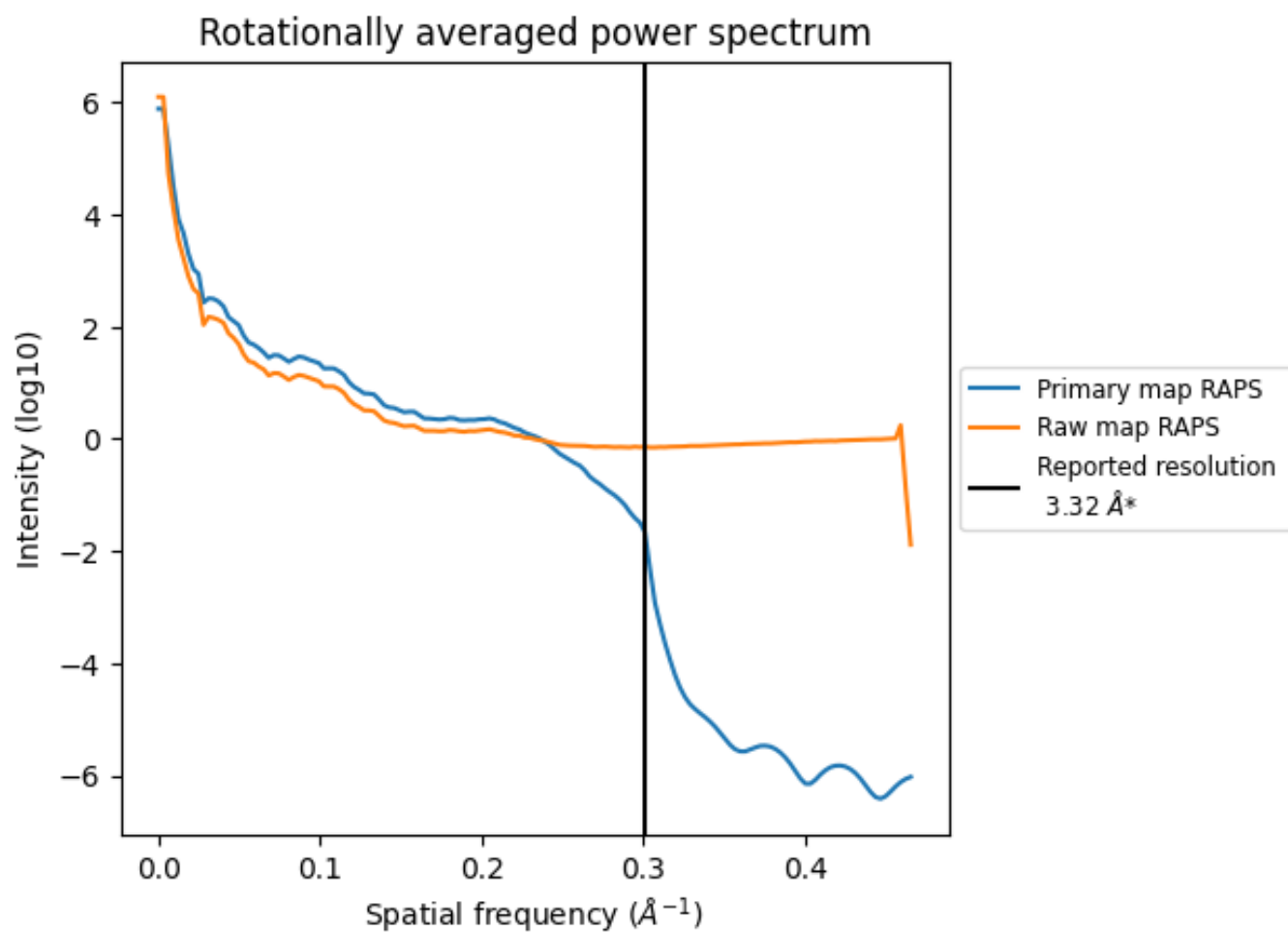

\*Reported resolution corresponds to spatial frequency of 0.301 Å<sup>-1</sup>

## 8 Fourier-Shell correlation [i](#)

Fourier-Shell Correlation (FSC) is the most commonly used method to estimate the resolution of single-particle and subtomogram-averaged maps. The shape of the curve depends on the imposed symmetry, mask and whether or not the two 3D reconstructions used were processed from a common reference. The reported resolution is shown as a black line. A curve is displayed for the half-bit criterion in addition to lines showing the 0.143 gold standard cut-off and 0.5 cut-off.

### 8.1 FSC [i](#)

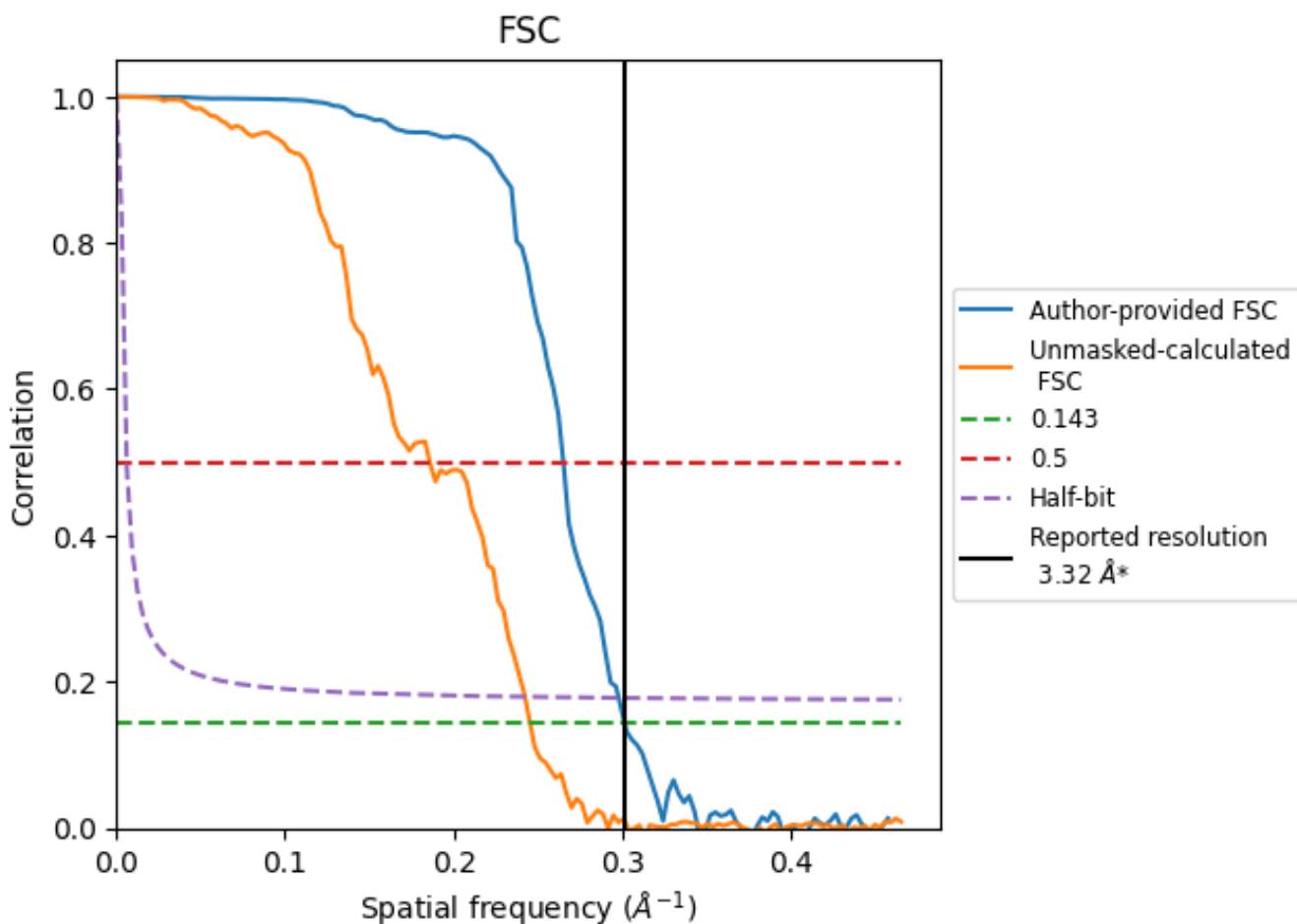

\*Reported resolution corresponds to spatial frequency of 0.301 Å<sup>-1</sup>

## 8.2 Resolution estimates [i](#)

Resolution estimate (Å)	Estimation criterion (FSC cut-off)		
	0.143	0.5	Half-bit
Reported by author	3.32	-	-
Author-provided FSC curve	3.32	3.77	3.36
Unmasked-calculated*	4.07	5.38	4.13

\*Resolution estimate based on FSC curve calculated by comparison of deposited half-maps. The value from deposited half-maps intersecting FSC 0.143 CUT-OFF 4.07 differs from the reported value 3.32 by more than 10 %

## 9 Map-model fit [i](#)

This section contains information regarding the fit between EMDB map EMD-38542 and PDB model 8XOW. Per-residue inclusion information can be found in section [3](#) on page [8](#).

### 9.1 Map-model overlay [i](#)

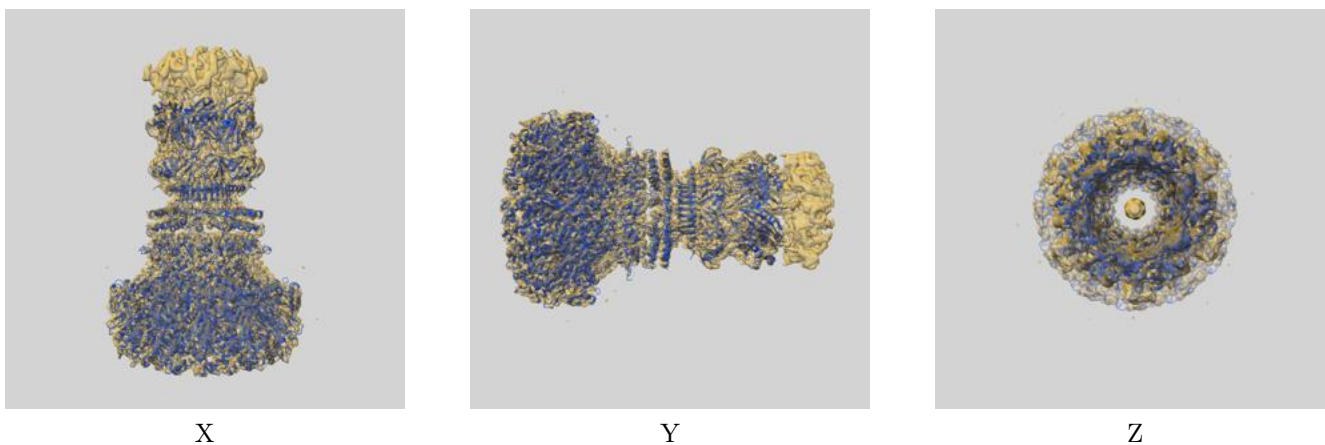

The images above show the 3D surface view of the map at the recommended contour level 0.3 at 50% transparency in yellow overlaid with a ribbon representation of the model coloured in blue. These images allow for the visual assessment of the quality of fit between the atomic model and the map.

## 9.2 Q-score mapped to coordinate model [i](#)

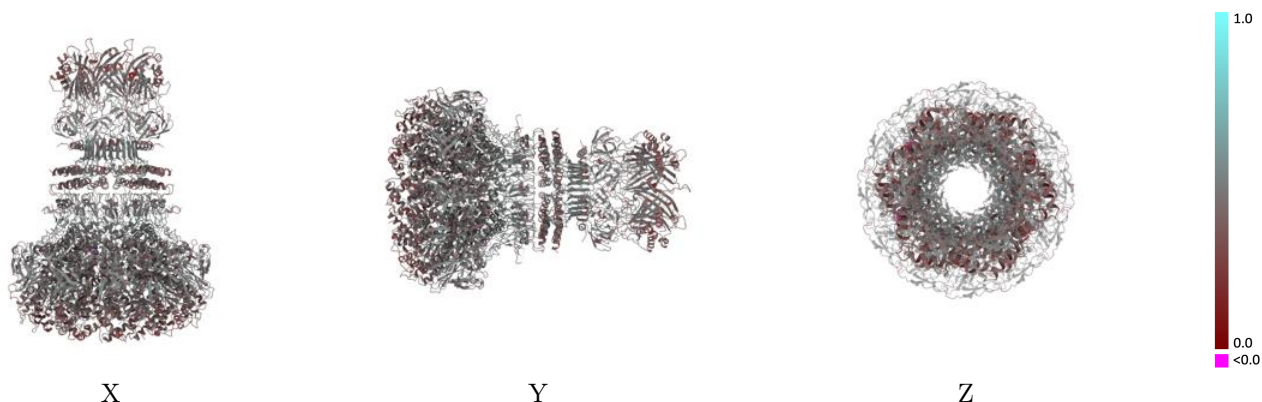

The images above show the model with each residue coloured according to its Q-score. This shows their resolvability in the map with higher Q-score values reflecting better resolvability. Please note: Q-score is calculating the resolvability of atoms, and thus high values are only expected at resolutions at which atoms can be resolved. Low Q-score values may therefore be expected for many entries.

## 9.3 Atom inclusion mapped to coordinate model [i](#)

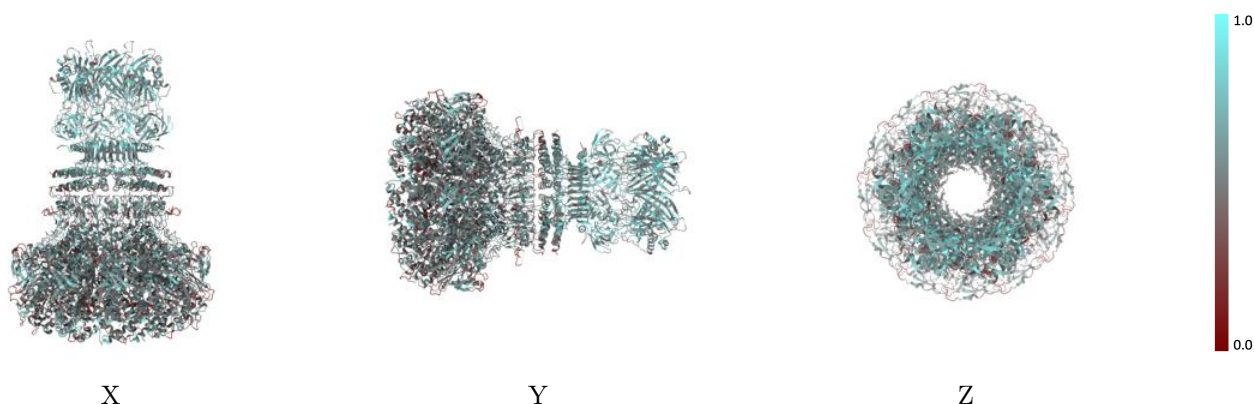

The images above show the model with each residue coloured according to its atom inclusion. This shows to what extent they are inside the map at the recommended contour level (0.3).

## 9.4 Atom inclusion [i](#)

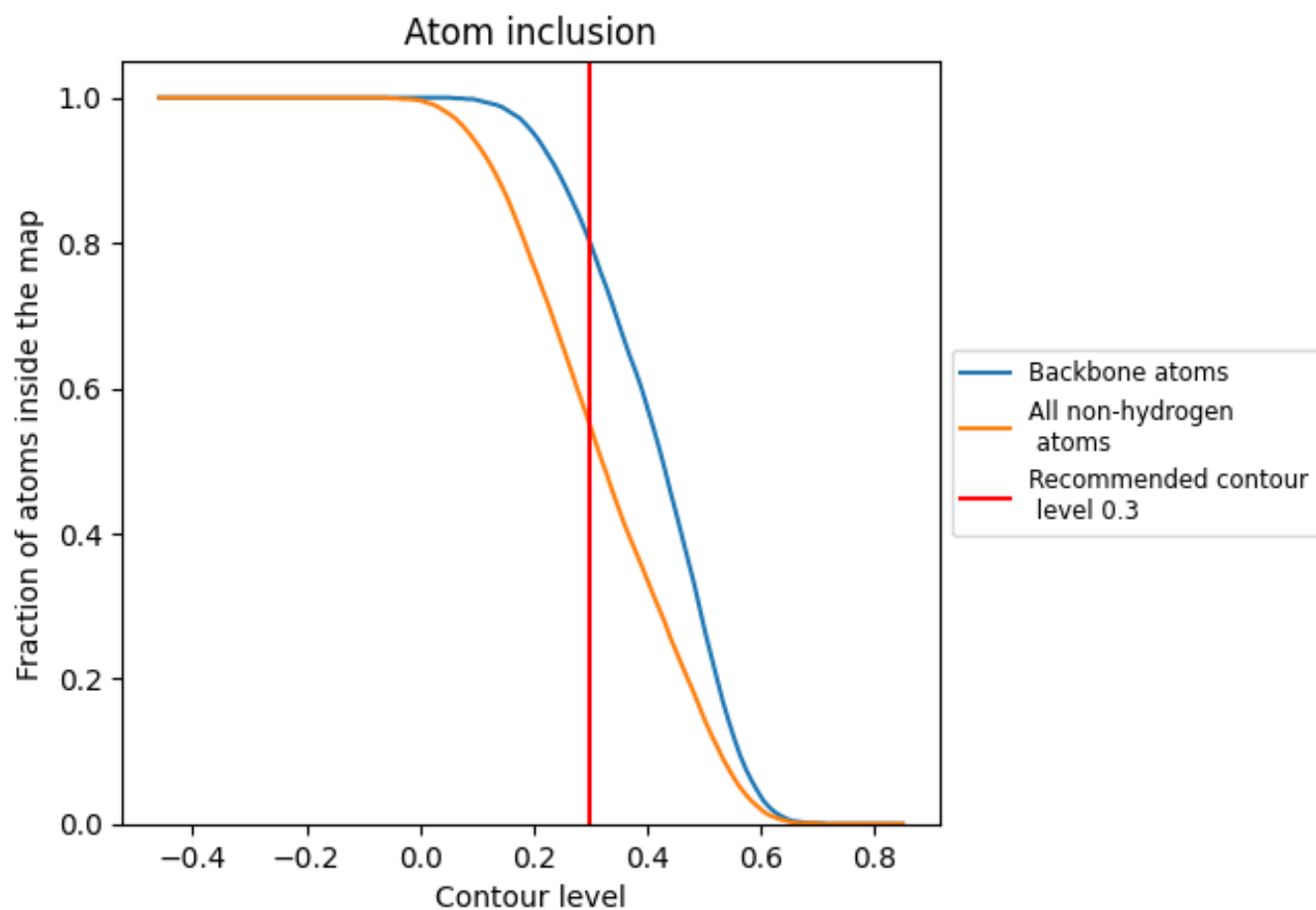







































































At the recommended contour level, 80% of all backbone atoms, 55% of all non-hydrogen atoms, are inside the map.



## 9.5 Map-model fit summary



The table lists the average atom inclusion at the recommended contour level (0.3) and Q-score for the entire model and for each chain.

Chain	Atom inclusion	Q-score
All	 0.5470	 0.4330
B	 0.5170	 0.4390
B1	 0.5240	 0.4360
B2	 0.5200	 0.4360
B3	 0.5210	 0.4360
B4	 0.5180	 0.4380
B5	 0.5200	 0.4340
U	 0.6160	 0.3810
U1	 0.6160	 0.3830
U2	 0.6170	 0.3860
U3	 0.6200	 0.3860
U4	 0.6140	 0.3850
U5	 0.6050	 0.3780
W	 0.5930	 0.4530
W1	 0.5830	 0.4470
W2	 0.5730	 0.4450
W3	 0.5710	 0.4490
W4	 0.5830	 0.4500
W5	 0.5770	 0.4510
b	 0.5160	 0.4390
b1	 0.5140	 0.4390
b2	 0.5190	 0.4380
b3	 0.5200	 0.4370
b4	 0.5230	 0.4390
b5	 0.5170	 0.4380
f	 0.6580	 0.4420
f1	 0.6530	 0.4290
f2	 0.6680	 0.4400
f3	 0.6560	 0.4400
f4	 0.6610	 0.4420
f5	 0.6550	 0.4370
w	 0.5930	 0.4410
w1	 0.5930	 0.4460
w2	 0.6010	 0.4390
w3	 0.5990	 0.4550



*Continued on next page...*

*Continued from previous page...*

Chain	Atom inclusion	Q-score
w4	 0.6050	 0.4470
w5	 0.5970	 0.4440