



wwPDB X-ray Structure Validation Summary Report ⓘ

Aug 16, 2023 – 11:15 AM EDT

PDB ID : 1ZUM
Title : Human Mitochondrial Aldehyde Dehydrogenase Asian Variant, ALDH2*2, Apo Form
Authors : Larson, H.N.; Weiner, H.; Hurley, T.D.
Deposited on : 2005-05-31
Resolution : 2.10 Å (reported)

This is a wwPDB X-ray Structure Validation Summary Report for a publicly released PDB entry.

We welcome your comments at validation@mail.wwpdb.org

A user guide is available at

<https://www.wwpdb.org/validation/2017/XrayValidationReportHelp>

with specific help available everywhere you see the ⓘ symbol.

The types of validation reports are described at

<http://www.wwpdb.org/validation/2017/FAQs#types>.

The following versions of software and data (see [references ⓘ](#)) were used in the production of this report:

MolProbity : 4.02b-467
Mogul : 1.8.5 (274361), CSD as541be (2020)
Xtriage (Phenix) : 1.13
EDS : 2.35
Percentile statistics : 20191225.v01 (using entries in the PDB archive December 25th 2019)
Refmac : 5.8.0158
CCP4 : 7.0.044 (Gargrove)
Ideal geometry (proteins) : Engh & Huber (2001)
Ideal geometry (DNA, RNA) : Parkinson et al. (1996)
Validation Pipeline (wwPDB-VP) : 2.35

1 Overall quality at a glance

The following experimental techniques were used to determine the structure:

X-RAY DIFFRACTION

The reported resolution of this entry is 2.10 Å.

Percentile scores (ranging between 0-100) for global validation metrics of the entry are shown in the following graphic. The table shows the number of entries on which the scores are based.

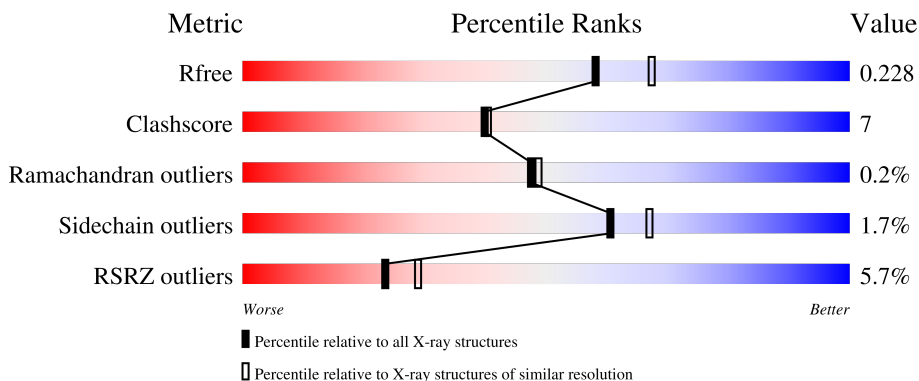

Metric	Whole archive (#Entries)	Similar resolution (#Entries, resolution range(Å))
R_{free}	130704	5197 (2.10-2.10)
Clashscore	141614	5710 (2.10-2.10)
Ramachandran outliers	138981	5647 (2.10-2.10)
Sidechain outliers	138945	5648 (2.10-2.10)
RSRZ outliers	127900	5083 (2.10-2.10)

The table below summarises the geometric issues observed across the polymeric chains and their fit to the electron density. The red, orange, yellow and green segments of the lower bar indicate the fraction of residues that contain outliers for ≥ 3 , 2, 1 and 0 types of geometric quality criteria respectively. A grey segment represents the fraction of residues that are not modelled. The numeric value for each fraction is indicated below the corresponding segment, with a dot representing fractions $\leq 5\%$. The upper red bar (where present) indicates the fraction of residues that have poor fit to the electron density. The numeric value is given above the bar.

Mol	Chain	Length	Quality of chain
1	A	500	 6% 80% 13% 6%
1	B	500	 2% 83% 8% • 7%
1	C	500	 2% 80% 12% • 6%
1	D	500	 7% 76% 17% • 6%
1	E	500	 3% 82% 11% • 6%

Continued on next page...

Continued from previous page...

Mol	Chain	Length	Quality of chain
1	F	500	<p>2% 81% 11% • 6%</p>
1	G	500	<p>2% 84% 9% 6%</p>
1	H	500	<p>3% 82% 12% 6%</p>
1	I	500	<p>6% 78% 15% • 6%</p>
1	J	500	<p>4% 80% 12% • 7%</p>
1	K	500	<p>6% 77% 14% • 9%</p>
1	L	500	<p>21% 74% 18% • 8%</p>

The following table lists non-polymeric compounds, carbohydrate monomers and non-standard residues in protein, DNA, RNA chains that are outliers for geometric or electron-density-fit criteria:

Mol	Type	Chain	Res	Chirality	Geometry	Clashes	Electron density
3	GAI	A	3101	-	-	X	-
3	GAI	I	3107	-	-	X	-
3	GAI	L	3108	-	-	X	-
4	EDO	A	3116	-	-	X	-
4	EDO	D	3126	-	-	X	-

2 Entry composition [i](#)

There are 5 unique types of molecules in this entry. The entry contains 46002 atoms, of which 0 are hydrogens and 0 are deuteriums.

In the tables below, the ZeroOcc column contains the number of atoms modelled with zero occupancy, the AltConf column contains the number of residues with at least one atom in alternate conformation and the Trace column contains the number of residues modelled with at most 2 atoms.

- Molecule 1 is a protein called Aldehyde dehydrogenase.

Mol	Chain	Residues	Atoms					ZeroOcc	AltConf	Trace
			Total	C	N	O	S			
1	A	469	Total 3620	C 2306	N 618	O 679	S 17	0	0	0
1	B	465	Total 3585	C 2286	N 610	O 672	S 17	0	0	0
1	C	468	Total 3612	C 2302	N 617	O 676	S 17	0	0	0
1	D	468	Total 3608	C 2301	N 613	O 677	S 17	0	0	0
1	E	469	Total 3624	C 2311	N 618	O 678	S 17	0	0	0
1	F	468	Total 3612	C 2302	N 617	O 676	S 17	0	0	0
1	G	469	Total 3624	C 2311	N 618	O 678	S 17	0	0	0
1	H	469	Total 3624	C 2311	N 618	O 678	S 17	0	0	0
1	I	468	Total 3615	C 2305	N 616	O 677	S 17	0	0	0
1	J	467	Total 3604	C 2299	N 612	O 676	S 17	0	0	0
1	K	456	Total 3526	C 2250	N 598	O 661	S 17	0	0	0
1	L	462	Total 3571	C 2279	N 607	O 668	S 17	0	0	0

There are 12 discrepancies between the modelled and reference sequences:

Chain	Residue	Modelled	Actual	Comment	Reference
A	487	LYS	GLU	engineered mutation	UNP P05091
B	487	LYS	GLU	engineered mutation	UNP P05091
C	487	LYS	GLU	engineered mutation	UNP P05091
D	487	LYS	GLU	engineered mutation	UNP P05091
E	487	LYS	GLU	engineered mutation	UNP P05091

Continued on next page...

Continued from previous page...

Chain	Residue	Modelled	Actual	Comment	Reference
F	487	LYS	GLU	engineered mutation	UNP P05091
G	487	LYS	GLU	engineered mutation	UNP P05091
H	487	LYS	GLU	engineered mutation	UNP P05091
I	487	LYS	GLU	engineered mutation	UNP P05091
J	487	LYS	GLU	engineered mutation	UNP P05091
K	487	LYS	GLU	engineered mutation	UNP P05091
L	487	LYS	GLU	engineered mutation	UNP P05091

- Molecule 2 is SODIUM ION (three-letter code: NA) (formula: Na).

Mol	Chain	Residues	Atoms	ZeroOcc	AltConf
2	A	1	Total Na 1 1	0	0
2	B	1	Total Na 1 1	0	0
2	C	1	Total Na 1 1	0	0
2	D	1	Total Na 1 1	0	0
2	E	1	Total Na 1 1	0	0
2	F	1	Total Na 1 1	0	0
2	G	1	Total Na 1 1	0	0
2	H	1	Total Na 1 1	0	0
2	I	1	Total Na 1 1	0	0
2	J	1	Total Na 1 1	0	0
2	K	1	Total Na 1 1	0	0
2	L	1	Total Na 1 1	0	0

- Molecule 3 is GUANIDINE (three-letter code: GAI) (formula: CH₅N₃).

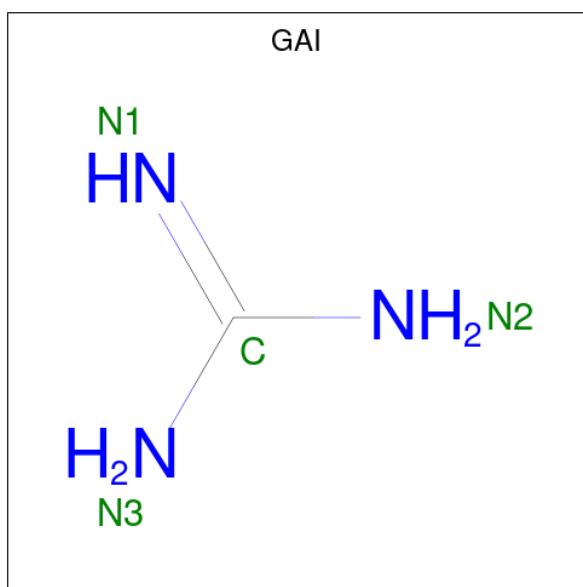

Mol	Chain	Residues	Atoms	ZeroOcc	AltConf
3	A	1	Total C N 4 1 3	0	0
3	E	1	Total C N 4 1 3	0	0
3	F	1	Total C N 4 1 3	0	0
3	F	1	Total C N 4 1 3	0	0
3	G	1	Total C N 4 1 3	0	0
3	H	1	Total C N 4 1 3	0	0
3	I	1	Total C N 4 1 3	0	0
3	L	1	Total C N 4 1 3	0	0

- Molecule 4 is 1,2-ETHANEDIOL (three-letter code: EDO) (formula: C₂H₆O₂).



Mol	Chain	Residues	Atoms	ZeroOcc	AltConf
4	A	1	Total C O 4 2 2	0	0
4	A	1	Total C O 4 2 2	0	0
4	A	1	Total C O 4 2 2	0	0
4	A	1	Total C O 4 2 2	0	0
4	B	1	Total C O 4 2 2	0	0
4	C	1	Total C O 4 2 2	0	0
4	C	1	Total C O 4 2 2	0	0
4	C	1	Total C O 4 2 2	0	0
4	D	1	Total C O 4 2 2	0	0
4	D	1	Total C O 4 2 2	0	0
4	E	1	Total C O 4 2 2	0	0
4	F	1	Total C O 4 2 2	0	0
4	F	1	Total C O 4 2 2	0	0
4	F	1	Total C O 4 2 2	0	0

Continued on next page...

Continued from previous page...

Mol	Chain	Residues	Atoms	ZeroOcc	AltConf
4	G	1	Total C O 4 2 2	0	0
4	G	1	Total C O 4 2 2	0	0
4	G	1	Total C O 4 2 2	0	0
4	I	1	Total C O 4 2 2	0	0
4	I	1	Total C O 4 2 2	0	0
4	J	1	Total C O 4 2 2	0	0
4	L	1	Total C O 4 2 2	0	0

- Molecule 5 is water.

Mol	Chain	Residues	Atoms	ZeroOcc	AltConf
5	A	189	Total O 189 189	0	0
5	B	299	Total O 299 299	0	0
5	C	290	Total O 290 290	0	0
5	D	187	Total O 187 187	0	0
5	E	285	Total O 285 285	0	0
5	F	367	Total O 367 367	0	0
5	G	285	Total O 285 285	0	0
5	H	236	Total O 236 236	0	0
5	I	189	Total O 189 189	0	0
5	J	141	Total O 141 141	0	0
5	K	93	Total O 93 93	0	0
5	L	88	Total O 88 88	0	0

3 Residue-property plots i

These plots are drawn for all protein, RNA, DNA and oligosaccharide chains in the entry. The first graphic for a chain summarises the proportions of the various outlier classes displayed in the second graphic. The second graphic shows the sequence view annotated by issues in geometry and electron density. Residues are color-coded according to the number of geometric quality criteria for which they contain at least one outlier: green = 0, yellow = 1, orange = 2 and red = 3 or more. A red dot above a residue indicates a poor fit to the electron density ($RSRZ > 2$). Stretches of 2 or more consecutive residues without any outlier are shown as a green connector. Residues present in the sample, but not in the model, are shown in grey.

- Molecule 1: Aldehyde dehydrogenase

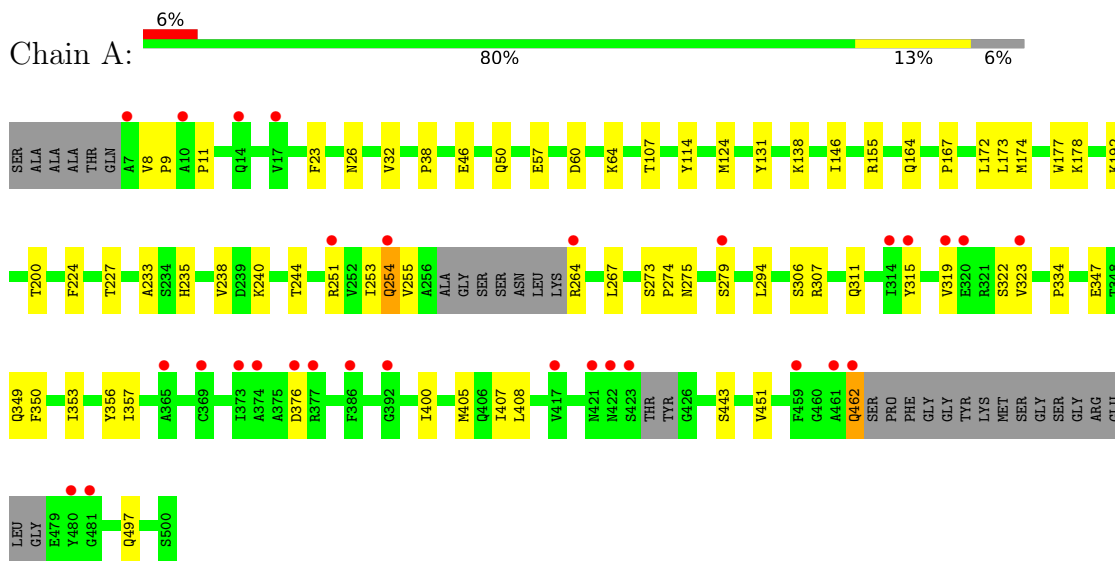

- Molecule 1: Aldehyde dehydrogenase

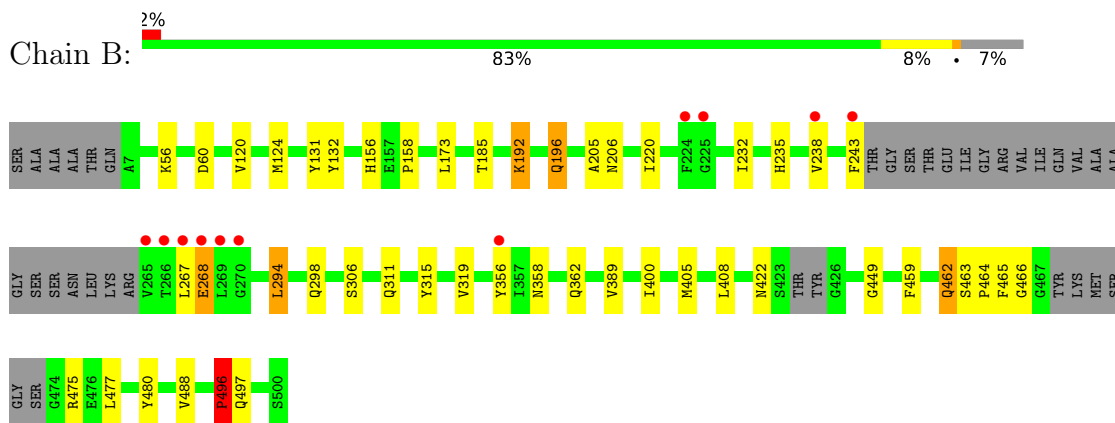

- Molecule 1: Aldehyde dehydrogenase

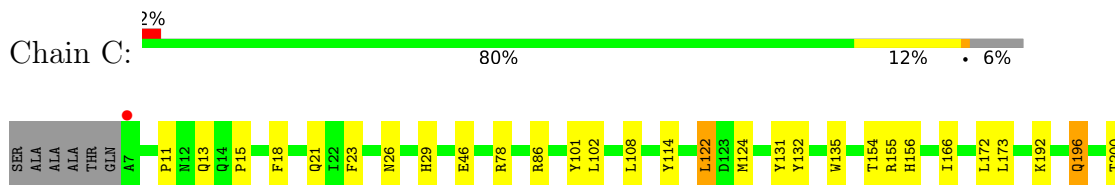

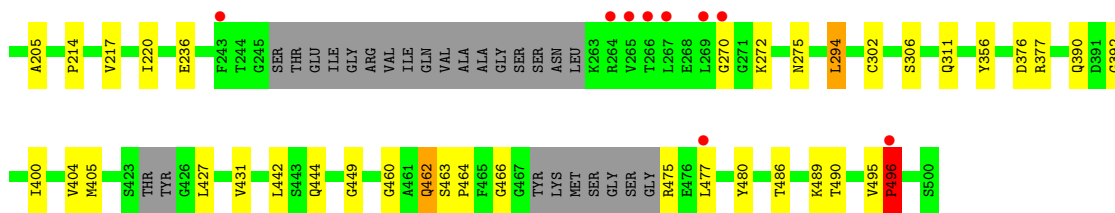

• Molecule 1: Aldehyde dehydrogenase

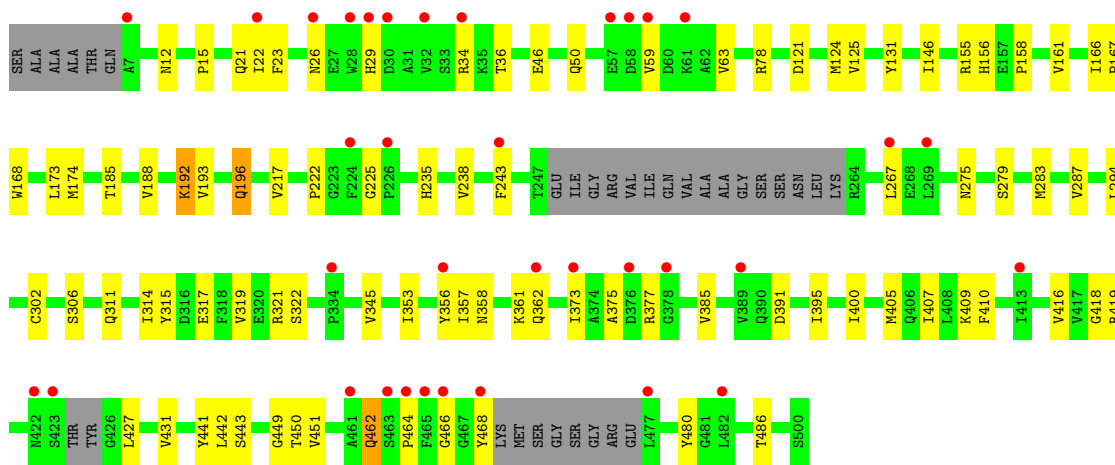
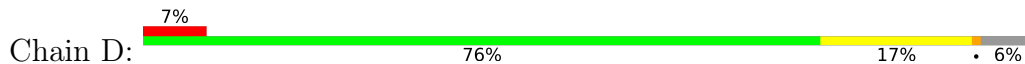

• Molecule 1: Aldehyde dehydrogenase

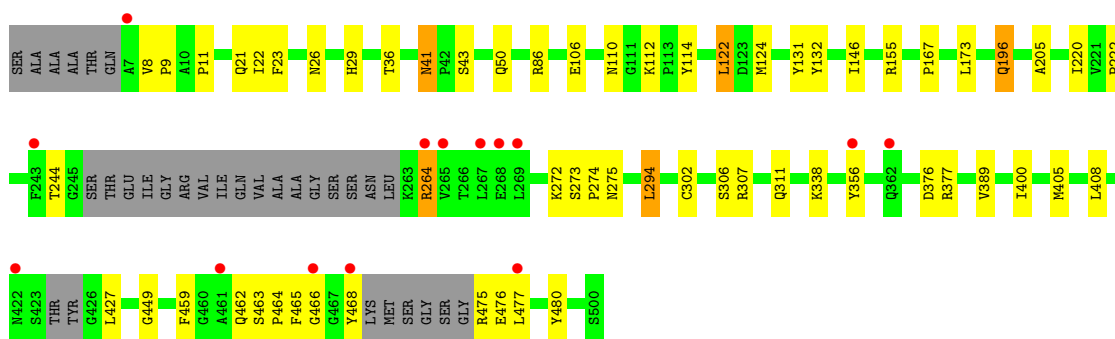
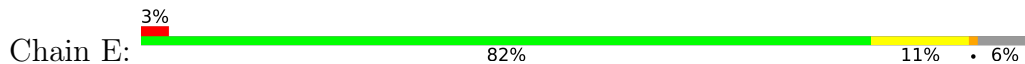

• Molecule 1: Aldehyde dehydrogenase

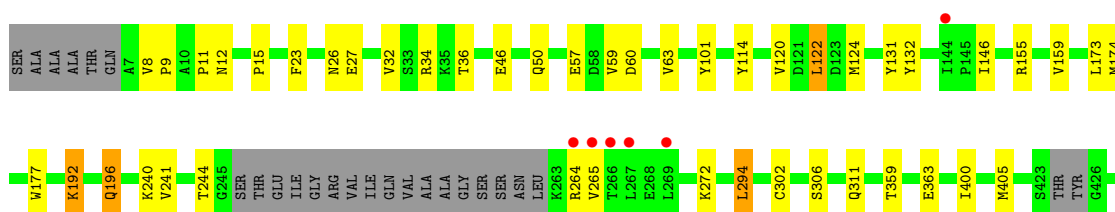
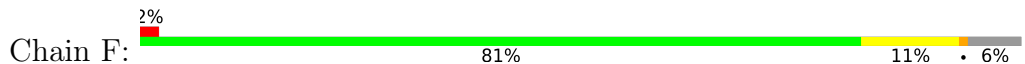

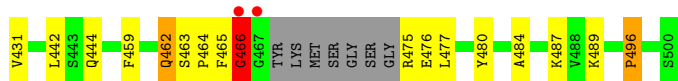

- Molecule 1: Aldehyde dehydrogenase

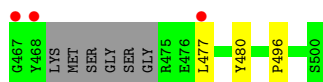
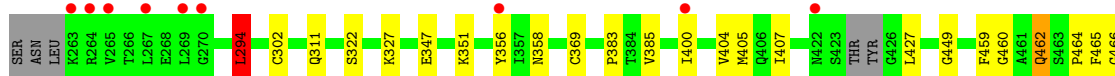
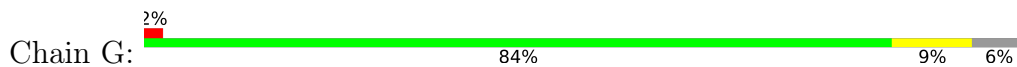

- Molecule 1: Aldehyde dehydrogenase

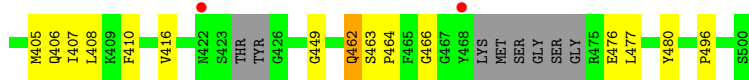
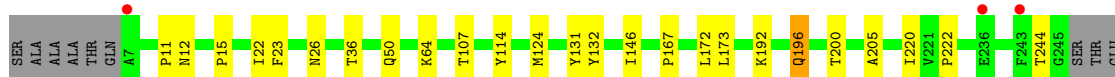
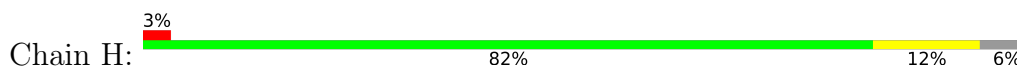

- Molecule 1: Aldehyde dehydrogenase

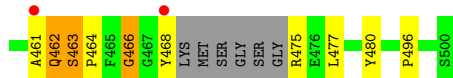
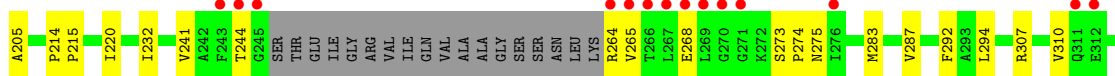
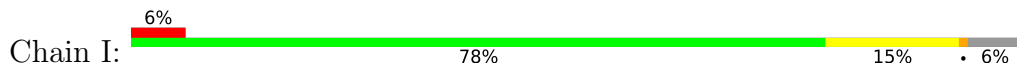

- Molecule 1: Aldehyde dehydrogenase

Chain J: 4% 80% 12% 7%

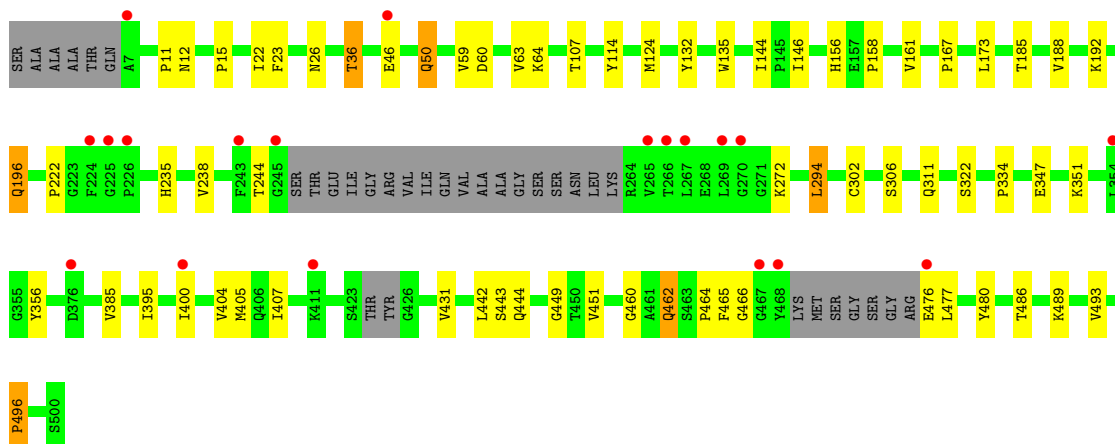

• Molecule 1: Aldehyde dehydrogenase

Chain K: 6% 77% 14% 9%

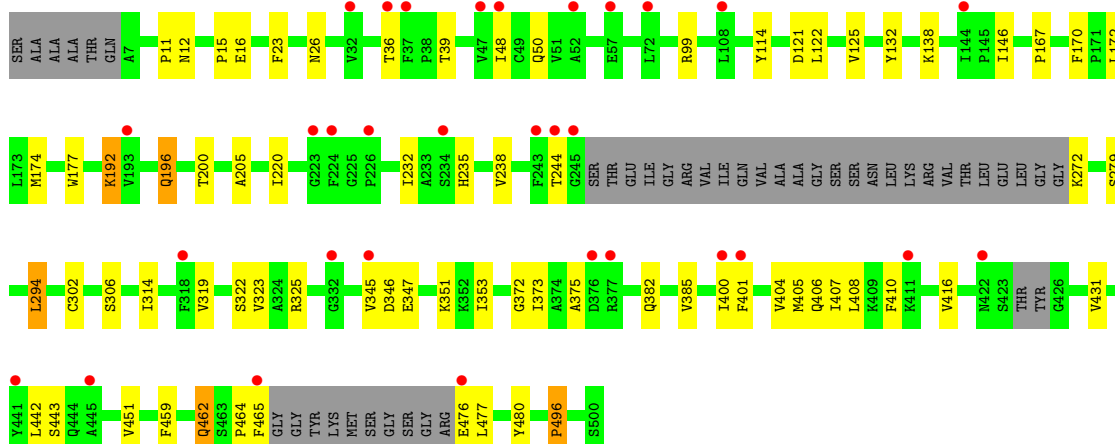

• Molecule 1: Aldehyde dehydrogenase

Chain L: 21% 74% 18% 8%

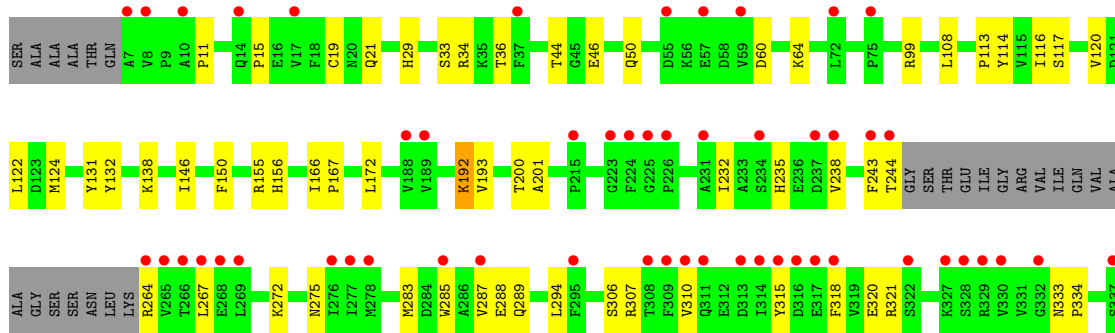

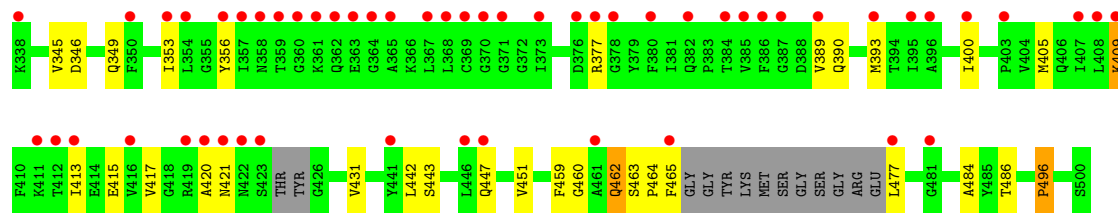

4 Data and refinement statistics

Property	Value	Source
Space group	P 1	Depositor
Cell constants a, b, c, α , β , γ	95.87Å 105.26Å 162.67Å 78.81° 81.95° 88.04°	Depositor
Resolution (Å)	42.63 – 2.10 42.62 – 2.11	Depositor EDS
% Data completeness (in resolution range)	97.7 (42.63-2.10) 97.1 (42.62-2.11)	Depositor EDS
R_{merge}	0.05	Depositor
R_{sym}	(Not available)	Depositor
$\langle I/\sigma(I) \rangle$ ¹	1.33 (at 2.10Å)	Xtrriage
Refinement program	CNS 1.1	Depositor
R, R_{free}	0.204 , 0.238 0.198 , 0.228	Depositor DCC
R_{free} test set	17348 reflections (5.03%)	wwPDB-VP
Wilson B-factor (Å ²)	31.4	Xtrriage
Anisotropy	0.266	Xtrriage
Bulk solvent k_{sol} (e/Å ³), B_{sol} (Å ²)	0.33 , 49.5	EDS
L-test for twinning ²	$\langle L \rangle = 0.49$, $\langle L^2 \rangle = 0.32$	Xtrriage
Estimated twinning fraction	No twinning to report.	Xtrriage
F_o, F_c correlation	0.95	EDS
Total number of atoms	46002	wwPDB-VP
Average B, all atoms (Å ²)	41.0	wwPDB-VP

Xtrriage's analysis on translational NCS is as follows: *The largest off-origin peak in the Patterson function is 2.84% of the height of the origin peak. No significant pseudotranslation is detected.*

¹Intensities estimated from amplitudes.

²Theoretical values of $\langle |L| \rangle$, $\langle L^2 \rangle$ for acentric reflections are 0.5, 0.333 respectively for untwinned datasets, and 0.375, 0.2 for perfectly twinned datasets.

5 Model quality [i](#)

5.1 Standard geometry [i](#)

Bond lengths and bond angles in the following residue types are not validated in this section: NA, GAI, EDO

The Z score for a bond length (or angle) is the number of standard deviations the observed value is removed from the expected value. A bond length (or angle) with $|Z| > 5$ is considered an outlier worth inspection. RMSZ is the root-mean-square of all Z scores of the bond lengths (or angles).

Mol	Chain	Bond lengths		Bond angles	
		RMSZ	# Z >5	RMSZ	# Z >5
1	A	0.41	0/3697	0.61	0/5015
1	B	0.51	0/3664	0.67	0/4969
1	C	0.52	0/3691	0.69	2/5004 (0.0%)
1	D	0.42	0/3688	0.61	0/5003
1	E	0.51	0/3704	0.68	1/5022 (0.0%)
1	F	0.56	0/3691	0.69	3/5004 (0.1%)
1	G	0.50	0/3704	0.66	1/5022 (0.0%)
1	H	0.50	0/3704	0.65	0/5022
1	I	0.41	0/3695	0.62	1/5011 (0.0%)
1	J	0.38	0/3684	0.60	0/4997
1	K	0.36	0/3605	0.58	0/4891
1	L	0.36	0/3650	0.58	0/4952
All	All	0.46	0/44177	0.64	8/59912 (0.0%)

There are no bond length outliers.

The worst 5 of 8 bond angle outliers are listed below:

Mol	Chain	Res	Type	Atoms	Z	Observed(°)	Ideal(°)
1	E	122	LEU	CA-CB-CG	-7.76	97.44	115.30
1	C	122	LEU	CA-CB-CG	-7.38	98.31	115.30
1	F	122	LEU	CA-CB-CG	-6.86	99.53	115.30
1	C	294	LEU	CA-CB-CG	-6.34	100.71	115.30
1	G	294	LEU	CA-CB-CG	-5.67	102.25	115.30

There are no chirality outliers.

There are no planarity outliers.

5.2 Too-close contacts

In the following table, the Non-H and H(model) columns list the number of non-hydrogen atoms and hydrogen atoms in the chain respectively. The H(added) column lists the number of hydrogen atoms added and optimized by MolProbity. The Clashes column lists the number of clashes within the asymmetric unit, whereas Symm-Clashes lists symmetry-related clashes.

Mol	Chain	Non-H	H(model)	H(added)	Clashes	Symm-Clashes
1	A	3620	0	3578	53	0
1	B	3585	0	3531	42	0
1	C	3612	0	3564	57	0
1	D	3608	0	3553	72	0
1	E	3624	0	3573	59	0
1	F	3612	0	3564	57	0
1	G	3624	0	3573	38	0
1	H	3624	0	3573	46	0
1	I	3615	0	3560	65	0
1	J	3604	0	3547	51	0
1	K	3526	0	3469	51	0
1	L	3571	0	3523	64	0
2	A	1	0	0	0	0
2	B	1	0	0	0	0
2	C	1	0	0	0	0
2	D	1	0	0	0	0
2	E	1	0	0	0	0
2	F	1	0	0	0	0
2	G	1	0	0	0	0
2	H	1	0	0	0	0
2	I	1	0	0	0	0
2	J	1	0	0	0	0
2	K	1	0	0	0	0
2	L	1	0	0	0	0
3	A	4	0	4	2	0
3	E	4	0	5	0	0
3	F	8	0	10	1	0
3	G	4	0	4	0	0
3	H	4	0	5	0	0
3	I	4	0	4	2	0
3	L	4	0	5	4	0
4	A	16	0	24	8	0
4	B	4	0	6	0	0
4	C	12	0	18	5	0
4	D	8	0	12	6	0
4	E	4	0	6	0	0
4	F	12	0	18	4	0

Continued on next page...

Continued from previous page...

Mol	Chain	Non-H	H(model)	H(added)	Clashes	Symm-Clashes
4	G	12	0	18	2	0
4	I	8	0	12	0	0
4	J	4	0	6	1	0
4	L	4	0	6	1	0
5	A	189	0	0	3	0
5	B	299	0	0	5	0
5	C	290	0	0	5	0
5	D	187	0	0	5	0
5	E	285	0	0	6	0
5	F	367	0	0	9	0
5	G	285	0	0	6	0
5	H	236	0	0	2	0
5	I	189	0	0	4	0
5	J	141	0	0	3	0
5	K	93	0	0	1	0
5	L	88	0	0	6	0
All	All	46002	0	42771	629	0

The all-atom clashscore is defined as the number of clashes found per 1000 atoms (including hydrogen atoms). The all-atom clashscore for this structure is 7.

The worst 5 of 629 close contacts within the same asymmetric unit are listed below, sorted by their clash magnitude.

Atom-1	Atom-2	Interatomic distance (Å)	Clash overlap (Å)
1:H:124:MET:HE3	1:H:173:LEU:HD22	1.52	0.89
1:C:196:GLN:HE21	1:C:196:GLN:H	1.20	0.88
1:I:466:GLY:HA3	1:I:475:ARG:HD3	1.53	0.87
1:A:131:TYR:CE1	1:A:462:GLN:HG3	2.11	0.86
1:L:36:THR:OG1	1:L:50:GLN:HG3	1.75	0.86

There are no symmetry-related clashes.

5.3 Torsion angles [i](#)

5.3.1 Protein backbone [i](#)

In the following table, the Percentiles column shows the percent Ramachandran outliers of the chain as a percentile score with respect to all X-ray entries followed by that with respect to entries of similar resolution.

The Analysed column shows the number of residues for which the backbone conformation was analysed, and the total number of residues.

Mol	Chain	Analysed	Favoured	Allowed	Outliers	Percentiles	
1	A	461/500 (92%)	451 (98%)	10 (2%)	0	100	100
1	B	457/500 (91%)	449 (98%)	7 (2%)	1 (0%)	47	49
1	C	460/500 (92%)	451 (98%)	8 (2%)	1 (0%)	47	49
1	D	460/500 (92%)	448 (97%)	12 (3%)	0	100	100
1	E	461/500 (92%)	449 (97%)	12 (3%)	0	100	100
1	F	460/500 (92%)	451 (98%)	7 (2%)	2 (0%)	34	32
1	G	461/500 (92%)	452 (98%)	8 (2%)	1 (0%)	47	49
1	H	461/500 (92%)	452 (98%)	8 (2%)	1 (0%)	47	49
1	I	460/500 (92%)	448 (97%)	10 (2%)	2 (0%)	34	32
1	J	459/500 (92%)	448 (98%)	10 (2%)	1 (0%)	47	49
1	K	448/500 (90%)	437 (98%)	10 (2%)	1 (0%)	47	49
1	L	454/500 (91%)	443 (98%)	10 (2%)	1 (0%)	47	49
All	All	5502/6000 (92%)	5379 (98%)	112 (2%)	11 (0%)	47	49

5 of 11 Ramachandran outliers are listed below:

Mol	Chain	Res	Type
1	B	496	PRO
1	F	466	GLY
1	I	466	GLY
1	J	496	PRO
1	C	496	PRO

5.3.2 Protein sidechains [i](#)

In the following table, the Percentiles column shows the percent sidechain outliers of the chain as a percentile score with respect to all X-ray entries followed by that with respect to entries of similar resolution.

The Analysed column shows the number of residues for which the sidechain conformation was analysed, and the total number of residues.

Mol	Chain	Analysed	Rotameric	Outliers	Percentiles	
1	A	381/402 (95%)	375 (98%)	6 (2%)	62	69
1	B	376/402 (94%)	368 (98%)	8 (2%)	53	59

Continued on next page...

Continued from previous page...

Mol	Chain	Analysed	Rotameric	Outliers	Percentiles	
1	C	379/402 (94%)	370 (98%)	9 (2%)	49	53
1	D	379/402 (94%)	373 (98%)	6 (2%)	62	69
1	E	380/402 (94%)	373 (98%)	7 (2%)	59	65
1	F	379/402 (94%)	372 (98%)	7 (2%)	59	65
1	G	380/402 (94%)	376 (99%)	4 (1%)	73	79
1	H	380/402 (94%)	374 (98%)	6 (2%)	62	69
1	I	379/402 (94%)	374 (99%)	5 (1%)	69	75
1	J	378/402 (94%)	371 (98%)	7 (2%)	57	63
1	K	371/402 (92%)	365 (98%)	6 (2%)	62	69
1	L	376/402 (94%)	371 (99%)	5 (1%)	69	75
All	All	4538/4824 (94%)	4462 (98%)	76 (2%)	60	67

5 of 76 residues with a non-rotameric sidechain are listed below:

Mol	Chain	Res	Type
1	I	463	SER
1	L	117	SER
1	J	50	GLN
1	K	192	LYS
1	L	462	GLN

Sometimes sidechains can be flipped to improve hydrogen bonding and reduce clashes. 5 of 92 such sidechains are listed below:

Mol	Chain	Res	Type
1	H	164	GLN
1	J	21	GLN
1	H	196	GLN
1	I	83	HIS
1	J	275	ASN

5.3.3 RNA

There are no RNA molecules in this entry.

5.4 Non-standard residues in protein, DNA, RNA chains [i](#)

There are no non-standard protein/DNA/RNA residues in this entry.

5.5 Carbohydrates [i](#)

There are no monosaccharides in this entry.

5.6 Ligand geometry [i](#)

Of 41 ligands modelled in this entry, 12 are monoatomic - leaving 29 for Mogul analysis.

In the following table, the Counts columns list the number of bonds (or angles) for which Mogul statistics could be retrieved, the number of bonds (or angles) that are observed in the model and the number of bonds (or angles) that are defined in the Chemical Component Dictionary. The Link column lists molecule types, if any, to which the group is linked. The Z score for a bond length (or angle) is the number of standard deviations the observed value is removed from the expected value. A bond length (or angle) with $|Z| > 2$ is considered an outlier worth inspection. RMSZ is the root-mean-square of all Z scores of the bond lengths (or angles).

Mol	Type	Chain	Res	Link	Bond lengths			Bond angles		
					Counts	RMSZ	# Z > 2	Counts	RMSZ	# Z > 2
4	EDO	A	3116	-	3,3,3	0.63	0	2,2,2	0.06	0
3	GAI	G	3105	-	3,3,3	1.34	0	3,3,3	1.28	0
4	EDO	G	3125	-	3,3,3	0.49	0	2,2,2	0.39	0
4	EDO	D	3117	-	3,3,3	0.49	0	2,2,2	0.22	0
4	EDO	I	3127	-	3,3,3	0.39	0	2,2,2	0.51	0
4	EDO	J	3128	-	3,3,3	0.48	0	2,2,2	0.20	0
3	GAI	E	3102	-	3,3,3	1.54	1 (33%)	3,3,3	1.11	0
3	GAI	H	3106	-	3,3,3	1.44	1 (33%)	3,3,3	1.24	0
4	EDO	E	3118	-	3,3,3	0.45	0	2,2,2	0.27	0
4	EDO	F	3121	-	3,3,3	0.43	0	2,2,2	0.39	0
3	GAI	I	3107	-	3,3,3	1.37	1 (33%)	3,3,3	1.27	0
4	EDO	L	3129	-	3,3,3	0.51	0	2,2,2	0.26	0
4	EDO	G	3123	-	3,3,3	0.43	0	2,2,2	0.40	0
3	GAI	F	3104	-	3,3,3	1.60	1 (33%)	3,3,3	1.25	0
4	EDO	A	3109	-	3,3,3	0.43	0	2,2,2	0.29	0
3	GAI	A	3101	-	3,3,3	1.09	0	3,3,3	1.34	0
4	EDO	F	3120	-	3,3,3	0.39	0	2,2,2	0.33	0
4	EDO	I	3119	-	3,3,3	0.33	0	2,2,2	0.56	0
4	EDO	C	3115	-	3,3,3	0.40	0	2,2,2	0.46	0
4	EDO	C	3113	-	3,3,3	0.69	0	2,2,2	0.08	0
4	EDO	F	3122	-	3,3,3	0.35	0	2,2,2	0.51	0

Mol	Type	Chain	Res	Link	Bond lengths			Bond angles		
					Counts	RMSZ	# Z > 2	Counts	RMSZ	# Z > 2
4	EDO	C	3114	-	3,3,3	0.27	0	2,2,2	0.41	0
4	EDO	A	3110	-	3,3,3	0.43	0	2,2,2	0.29	0
4	EDO	B	3112	-	3,3,3	0.42	0	2,2,2	0.30	0
4	EDO	G	3124	-	3,3,3	0.48	0	2,2,2	0.23	0
4	EDO	A	3111	-	3,3,3	0.59	0	2,2,2	0.31	0
4	EDO	D	3126	-	3,3,3	0.42	0	2,2,2	0.40	0
3	GAI	L	3108	-	3,3,3	1.61	1 (33%)	3,3,3	1.24	0
3	GAI	F	3103	-	3,3,3	1.40	1 (33%)	3,3,3	1.25	0

In the following table, the Chirals column lists the number of chiral outliers, the number of chiral centers analysed, the number of these observed in the model and the number defined in the Chemical Component Dictionary. Similar counts are reported in the Torsion and Rings columns. '-' means no outliers of that kind were identified.

Mol	Type	Chain	Res	Link	Chirals	Torsions	Rings
4	EDO	A	3116	-	-	0/1/1/1	-
4	EDO	G	3125	-	-	1/1/1/1	-
4	EDO	D	3117	-	-	0/1/1/1	-
4	EDO	I	3127	-	-	1/1/1/1	-
4	EDO	J	3128	-	-	0/1/1/1	-
4	EDO	E	3118	-	-	0/1/1/1	-
4	EDO	F	3121	-	-	0/1/1/1	-
4	EDO	L	3129	-	-	0/1/1/1	-
4	EDO	G	3123	-	-	0/1/1/1	-
4	EDO	A	3109	-	-	0/1/1/1	-
4	EDO	F	3120	-	-	0/1/1/1	-
4	EDO	I	3119	-	-	1/1/1/1	-
4	EDO	C	3115	-	-	1/1/1/1	-
4	EDO	C	3113	-	-	0/1/1/1	-
4	EDO	F	3122	-	-	1/1/1/1	-
4	EDO	C	3114	-	-	0/1/1/1	-
4	EDO	A	3110	-	-	0/1/1/1	-
4	EDO	B	3112	-	-	0/1/1/1	-
4	EDO	G	3124	-	-	0/1/1/1	-
4	EDO	A	3111	-	-	1/1/1/1	-
4	EDO	D	3126	-	-	1/1/1/1	-

The worst 5 of 6 bond length outliers are listed below:

Mol	Chain	Res	Type	Atoms	Z	Observed(Å)	Ideal(Å)
3	L	3108	GAI	C-N1	2.60	1.36	1.30
3	H	3106	GAI	C-N1	2.45	1.35	1.30

Continued on next page...

Continued from previous page...

Mol	Chain	Res	Type	Atoms	Z	Observed(Å)	Ideal(Å)
3	E	3102	GAI	C-N1	2.38	1.35	1.30
3	F	3103	GAI	C-N1	2.34	1.35	1.30
3	F	3104	GAI	C-N1	2.33	1.35	1.30

There are no bond angle outliers.

There are no chirality outliers.

5 of 7 torsion outliers are listed below:

Mol	Chain	Res	Type	Atoms
4	A	3111	EDO	O1-C1-C2-O2
4	C	3115	EDO	O1-C1-C2-O2
4	D	3126	EDO	O1-C1-C2-O2
4	F	3122	EDO	O1-C1-C2-O2
4	G	3125	EDO	O1-C1-C2-O2

There are no ring outliers.

19 monomers are involved in 36 short contacts:

Mol	Chain	Res	Type	Clashes	Symm-Clashes
4	A	3116	EDO	5	0
4	D	3117	EDO	1	0
4	J	3128	EDO	1	0
4	F	3121	EDO	2	0
3	I	3107	GAI	2	0
4	L	3129	EDO	1	0
4	G	3123	EDO	1	0
4	A	3109	EDO	1	0
3	A	3101	GAI	2	0
4	F	3120	EDO	1	0
4	C	3115	EDO	3	0
4	C	3113	EDO	1	0
4	F	3122	EDO	1	0
4	C	3114	EDO	1	0
4	A	3110	EDO	2	0
4	G	3124	EDO	1	0
4	D	3126	EDO	5	0
3	L	3108	GAI	4	0
3	F	3103	GAI	1	0

5.7 Other polymers

There are no such residues in this entry.

5.8 Polymer linkage issues

There are no chain breaks in this entry.

6 Fit of model and data [i](#)

6.1 Protein, DNA and RNA chains [i](#)

In the following table, the column labelled ‘#RSRZ> 2’ contains the number (and percentage) of RSRZ outliers, followed by percent RSRZ outliers for the chain as percentile scores relative to all X-ray entries and entries of similar resolution. The OWAB column contains the minimum, median, 95th percentile and maximum values of the occupancy-weighted average B-factor per residue. The column labelled ‘Q< 0.9’ lists the number of (and percentage) of residues with an average occupancy less than 0.9.

Mol	Chain	Analysed	<RSRZ>	#RSRZ>2	OWAB(Å ²)	Q<0.9
1	A	469/500 (93%)	0.46	30 (6%) 19 24	13, 49, 74, 82	0
1	B	465/500 (93%)	-0.06	11 (2%) 59 64	15, 28, 50, 92	0
1	C	468/500 (93%)	-0.15	10 (2%) 63 68	14, 27, 56, 83	0
1	D	468/500 (93%)	0.38	35 (7%) 14 18	15, 45, 71, 83	0
1	E	469/500 (93%)	-0.08	14 (2%) 50 56	12, 29, 53, 83	0
1	F	468/500 (93%)	-0.24	8 (1%) 70 74	13, 24, 48, 83	0
1	G	469/500 (93%)	-0.09	12 (2%) 56 61	15, 30, 56, 79	0
1	H	469/500 (93%)	-0.02	13 (2%) 53 59	13, 33, 62, 78	0
1	I	468/500 (93%)	0.28	31 (6%) 18 23	25, 43, 74, 86	0
1	J	467/500 (93%)	0.24	19 (4%) 37 43	26, 47, 70, 87	0
1	K	456/500 (91%)	0.44	31 (6%) 17 21	34, 53, 73, 92	0
1	L	462/500 (92%)	1.22	107 (23%) 0 0	32, 64, 88, 95	0
All	All	5598/6000 (93%)	0.20	321 (5%) 23 29	12, 39, 74, 95	0

The worst 5 of 321 RSRZ outliers are listed below:

Mol	Chain	Res	Type	RSRZ
1	B	267	LEU	7.9
1	I	413	ILE	7.7
1	L	267	LEU	7.7
1	F	269	LEU	7.2
1	L	413	ILE	7.1

6.2 Non-standard residues in protein, DNA, RNA chains [i](#)

There are no non-standard protein/DNA/RNA residues in this entry.

6.3 Carbohydrates [i](#)

There are no monosaccharides in this entry.

6.4 Ligands [i](#)

In the following table, the Atoms column lists the number of modelled atoms in the group and the number defined in the chemical component dictionary. The B-factors column lists the minimum, median, 95th percentile and maximum values of B factors of atoms in the group. The column labelled 'Q< 0.9' lists the number of atoms with occupancy less than 0.9.

Mol	Type	Chain	Res	Atoms	RSCC	RSR	B-factors(\AA^2)	Q<0.9
3	GAI	L	3108	4/4	0.57	0.36	52,53,55,57	0
4	EDO	A	3116	4/4	0.64	0.33	47,49,53,54	0
4	EDO	C	3113	4/4	0.67	0.21	53,54,57,57	0
4	EDO	D	3117	4/4	0.72	0.23	50,54,56,56	0
2	NA	D	3704	1/1	0.73	0.11	55,55,55,55	0
4	EDO	J	3128	4/4	0.74	0.22	51,52,54,56	0
2	NA	J	3710	1/1	0.77	0.10	48,48,48,48	0
2	NA	A	3701	1/1	0.78	0.14	57,57,57,57	0
4	EDO	A	3110	4/4	0.80	0.35	55,57,57,58	0
3	GAI	F	3103	4/4	0.81	0.25	52,55,55,58	0
4	EDO	I	3119	4/4	0.83	0.25	53,53,57,61	0
4	EDO	A	3111	4/4	0.84	0.21	55,57,57,58	0
4	EDO	D	3126	4/4	0.84	0.17	55,58,59,59	0
4	EDO	I	3127	4/4	0.85	0.33	52,52,57,58	0
4	EDO	C	3115	4/4	0.86	0.25	53,53,57,59	0
2	NA	K	3711	1/1	0.86	0.18	73,73,73,73	0
4	EDO	L	3129	4/4	0.86	0.15	55,55,56,57	0
4	EDO	G	3123	4/4	0.88	0.19	51,55,55,56	0
4	EDO	G	3124	4/4	0.88	0.16	41,48,51,52	0
3	GAI	I	3107	4/4	0.88	0.28	48,50,53,54	0
3	GAI	A	3101	4/4	0.90	0.21	40,43,45,45	0
4	EDO	F	3122	4/4	0.90	0.26	47,50,54,56	0
2	NA	C	3703	1/1	0.91	0.10	34,34,34,34	0
4	EDO	A	3109	4/4	0.91	0.19	47,51,51,56	0
4	EDO	E	3118	4/4	0.92	0.16	39,49,51,53	0
4	EDO	B	3112	4/4	0.93	0.14	38,44,48,50	0
2	NA	L	3712	1/1	0.93	0.13	60,60,60,60	0
3	GAI	H	3106	4/4	0.93	0.15	48,48,49,50	0
4	EDO	G	3125	4/4	0.93	0.21	56,56,58,59	0
3	GAI	E	3102	4/4	0.94	0.16	34,38,40,44	0
4	EDO	F	3120	4/4	0.94	0.23	50,52,55,55	0
2	NA	H	3708	1/1	0.95	0.09	36,36,36,36	0

Continued on next page...

Continued from previous page...

Mol	Type	Chain	Res	Atoms	RSCC	RSR	B-factors(\AA^2)	Q<0.9
4	EDO	C	3114	4/4	0.95	0.20	43,45,46,50	0
3	GAI	G	3105	4/4	0.95	0.14	40,45,46,47	0
2	NA	E	3705	1/1	0.96	0.09	28,28,28,28	0
3	GAI	F	3104	4/4	0.96	0.18	46,46,46,47	0
2	NA	I	3709	1/1	0.97	0.10	36,36,36,36	0
2	NA	F	3706	1/1	0.97	0.07	25,25,25,25	0
2	NA	B	3702	1/1	0.97	0.09	30,30,30,30	0
4	EDO	F	3121	4/4	0.97	0.14	27,42,45,46	0
2	NA	G	3707	1/1	0.98	0.06	37,37,37,37	0

6.5 Other polymers [i](#)

There are no such residues in this entry.