



wwPDB EM Validation Summary Report ⓘ

Nov 5, 2023 – 11:57 pm GMT

PDB ID : 8CGV
EMDB ID : EMD-16652
Title : Tiamulin bound to the 50S subunit
Authors : Paternoga, H.; Crowe-McAuliffe, C.; Novacek, J.; Wilson, D.N.
Deposited on : 2023-02-06
Resolution : 1.66 Å(reported)

This is a wwPDB EM Validation Summary Report for a publicly released PDB entry.

We welcome your comments at validation@mail.wwpdb.org

A user guide is available at

<https://www.wwpdb.org/validation/2017/EMValidationReportHelp>

with specific help available everywhere you see the ⓘ symbol.

The types of validation reports are described at

<http://www.wwpdb.org/validation/2017/FAQs#types>.

The following versions of software and data (see [references ⓘ](#)) were used in the production of this report:

EMDB validation analysis : 0.0.1.dev70
Mogul : 1.8.4, CSD as541be (2020)
MolProbity : 4.02b-467
buster-report : 1.1.7 (2018)
Percentile statistics : 20191225.v01 (using entries in the PDB archive December 25th 2019)
MapQ : 1.9.9
Ideal geometry (proteins) : Engh & Huber (2001)
Ideal geometry (DNA, RNA) : Parkinson et al. (1996)
Validation Pipeline (wwPDB-VP) : 2.36

1 Overall quality at a glance

The following experimental techniques were used to determine the structure:
ELECTRON MICROSCOPY

The reported resolution of this entry is 1.66 Å.

Percentile scores (ranging between 0-100) for global validation metrics of the entry are shown in the following graphic. The table shows the number of entries on which the scores are based.

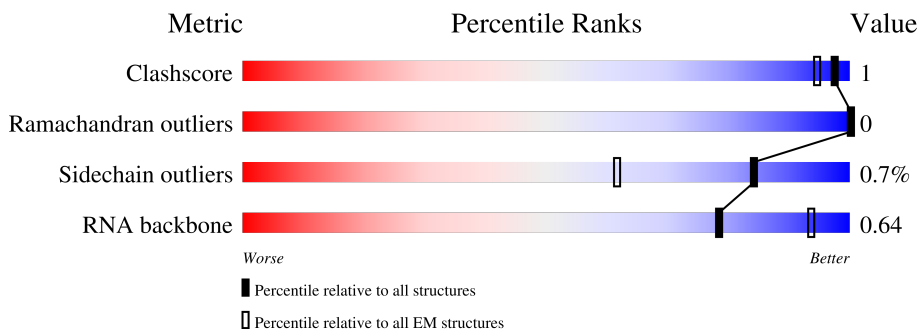







Metric	Whole archive (#Entries)	EM structures (#Entries)
Clashscore	158937	4297
Ramachandran outliers	154571	4023
Sidechain outliers	154315	3826
RNA backbone	4643	859

The table below summarises the geometric issues observed across the polymeric chains and their fit to the map. The red, orange, yellow and green segments of the bar indicate the fraction of residues that contain outliers for ≥ 3 , 2, 1 and 0 types of geometric quality criteria respectively. A grey segment represents the fraction of residues that are not modelled. The numeric value for each fraction is indicated below the corresponding segment, with a dot representing fractions $\leq 5\%$. The upper red bar (where present) indicates the fraction of residues that have poor fit to the EM map (all-atom inclusion $< 40\%$). The numeric value is given above the bar.

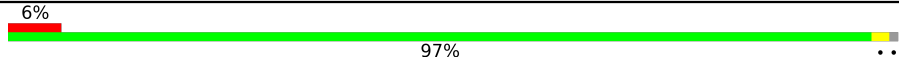
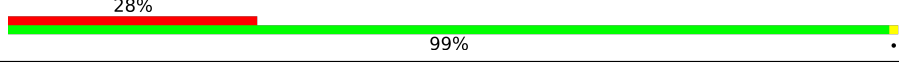
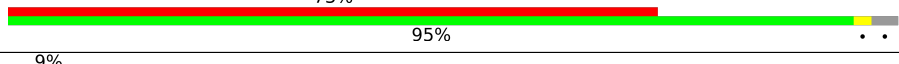
Mol	Chain	Length	Quality of chain
1	0	55	 16% 91% 7%
2	1	46	 96%
3	2	65	 97%
4	3	38	 5% 92% 8%
5	a	2904	 10% 80% 12% 7%
6	b	120	 7% 42% 53%
7	c	273	 99%

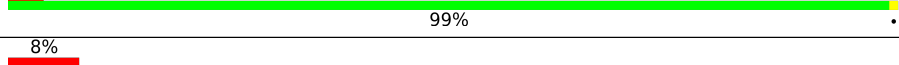
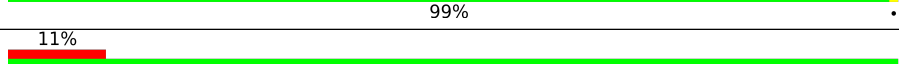
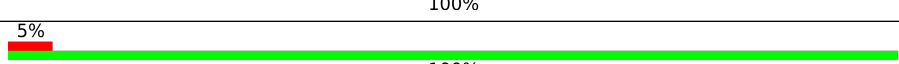
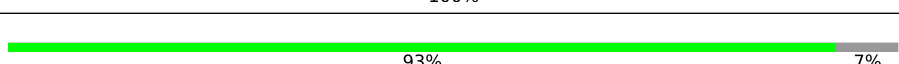
Continued on next page...

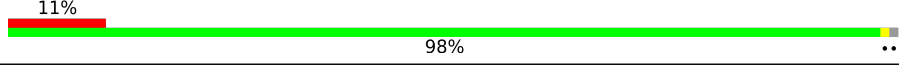
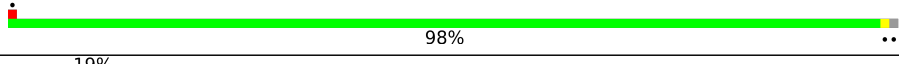
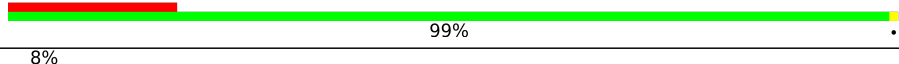
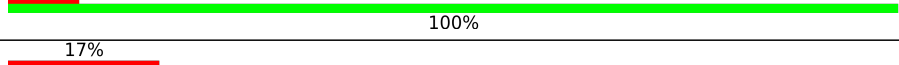
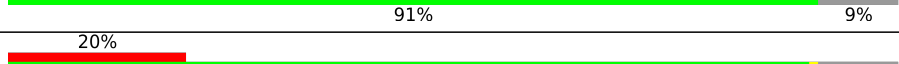
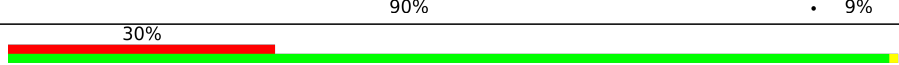
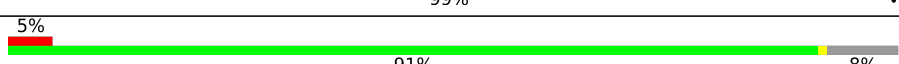
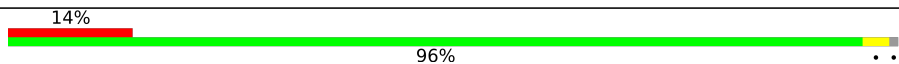
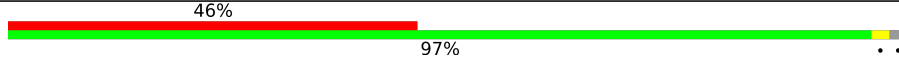
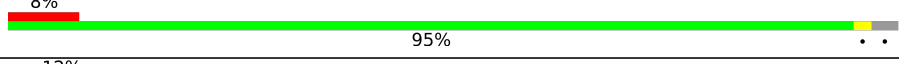
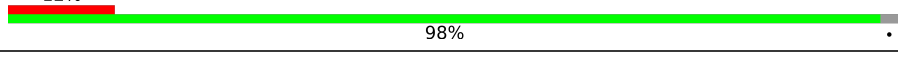
Continued from previous page...

Mol	Chain	Length	Quality of chain
8	d	209	
9	e	201	
10	g	177	
11	h	149	
12	i	142	
13	j	123	
14	k	144	
15	l	136	
16	m	127	
17	n	117	
18	o	115	
19	p	118	
20	q	103	
21	r	110	
22	s	100	
23	t	104	
24	u	94	
25	v	85	
26	w	78	
27	x	63	
28	y	59	
29	z	57	

2 Entry composition [i](#)

There are 35 unique types of molecules in this entry. The entry contains 87899 atoms, of which 0 are hydrogens and 0 are deuteriums.

In the tables below, the AltConf column contains the number of residues with at least one atom in alternate conformation and the Trace column contains the number of residues modelled with at most 2 atoms.

- Molecule 1 is a protein called Large ribosomal subunit protein bL33.

Mol	Chain	Residues	Atoms				AltConf	Trace
			Total	C	N	O		
1	0	51	417	269	76	72	0	0

- Molecule 2 is a protein called Large ribosomal subunit protein bL34.

Mol	Chain	Residues	Atoms					AltConf	Trace
			Total	C	N	O	S		
2	1	46	377	228	90	57	2	0	0

- Molecule 3 is a protein called Large ribosomal subunit protein bL35.

Mol	Chain	Residues	Atoms					AltConf	Trace
			Total	C	N	O	S		
3	2	64	504	323	105	74	2	0	0

- Molecule 4 is a protein called Large ribosomal subunit protein bL36A.

Mol	Chain	Residues	Atoms					AltConf	Trace
			Total	C	N	O	S		
4	3	38	302	185	65	48	4	0	0

- Molecule 5 is a RNA chain called 23S rRNA.

Mol	Chain	Residues	Atoms					AltConf	Trace
			Total	C	N	O	P		
5	a	2687	57720	25754	10642	18637	2687	0	0

- Molecule 6 is a RNA chain called 5S rRNA.

Mol	Chain	Residues	Atoms					AltConf	Trace
			Total	C	N	O	P		
6	b	56	1209	537	225	391	56	0	0

- Molecule 7 is a protein called Large ribosomal subunit protein uL2.

Mol	Chain	Residues	Atoms					AltConf	Trace
			Total	C	N	O	S		
7	c	271	2082	1288	423	364	7	0	0

- Molecule 8 is a protein called Large ribosomal subunit protein uL3.

Mol	Chain	Residues	Atoms					AltConf	Trace
			Total	C	N	O	S		
8	d	207	1552	972	286	291	3	0	0

- Molecule 9 is a protein called Large ribosomal subunit protein uL4.

Mol	Chain	Residues	Atoms					AltConf	Trace
			Total	C	N	O	S		
9	e	201	1552	974	283	290	5	0	0

- Molecule 10 is a protein called Large ribosomal subunit protein uL6.

Mol	Chain	Residues	Atoms					AltConf	Trace
			Total	C	N	O	S		
10	g	172	1292	815	236	239	2	0	0

- Molecule 11 is a protein called Large ribosomal subunit protein bL9.

Mol	Chain	Residues	Atoms					AltConf	Trace
			Total	C	N	O	S		
11	h	27	204	133	36	34	1	0	0

- Molecule 12 is a protein called Large ribosomal subunit protein uL13.

Mol	Chain	Residues	Atoms					AltConf	Trace
			Total	C	N	O	S		
12	i	142	1129	714	212	199	4	0	0

- Molecule 13 is a protein called Large ribosomal subunit protein uL14.

Mol	Chain	Residues	Atoms					AltConf	Trace
			Total	C	N	O	S		
13	j	123	946	593	181	166	6	0	0

- Molecule 14 is a protein called 50S ribosomal protein L15.

Mol	Chain	Residues	Atoms					AltConf	Trace
14	k	144	Total	C	N	O	S	0	0
			1053	654	207	190	2		

- Molecule 15 is a protein called Large ribosomal subunit protein uL16.

Mol	Chain	Residues	Atoms					AltConf	Trace
15	l	136	Total	C	N	O	S	0	0
			1075	686	205	177	7		

There is a discrepancy between the modelled and reference sequences:

Chain	Residue	Modelled	Actual	Comment	Reference
l	82	MS6	MET	modified residue	UNP P0ADY7

- Molecule 16 is a protein called Large ribosomal subunit protein bL17.

Mol	Chain	Residues	Atoms					AltConf	Trace
16	m	118	Total	C	N	O	S	0	0
			945	585	194	161	5		

- Molecule 17 is a protein called Large ribosomal subunit protein uL18.

Mol	Chain	Residues	Atoms				AltConf	Trace
17	n	26	Total	C	N	O	0	0
			213	128	51	34		

- Molecule 18 is a protein called Large ribosomal subunit protein bL19.

Mol	Chain	Residues	Atoms					AltConf	Trace
18	o	114	Total	C	N	O	S	0	0
			917	574	179	163	1		

- Molecule 19 is a protein called Large ribosomal subunit protein bL20.

Mol	Chain	Residues	Atoms				AltConf	Trace
19	p	117	Total	C	N	O	0	0
			947	604	192	151		

- Molecule 20 is a protein called Large ribosomal subunit protein bL21.

Mol	Chain	Residues	Atoms					AltConf	Trace
20	q	103	Total	C	N	O	S	0	0
			816	516	153	145	2		

- Molecule 21 is a protein called Large ribosomal subunit protein uL22.

Mol	Chain	Residues	Atoms					AltConf	Trace
21	r	110	Total	C	N	O	S	0	0
			857	532	166	156	3		

- Molecule 22 is a protein called Large ribosomal subunit protein uL23.

Mol	Chain	Residues	Atoms					AltConf	Trace
22	s	91	Total	C	N	O	S	0	0
			722	456	136	128	2		

- Molecule 23 is a protein called Large ribosomal subunit protein uL24.

Mol	Chain	Residues	Atoms				AltConf	Trace
23	t	95	Total	C	N	O	0	0
			728	459	137	132		

- Molecule 24 is a protein called 50S ribosomal protein L25.

Mol	Chain	Residues	Atoms					AltConf	Trace
24	u	94	Total	C	N	O	S	0	0
			753	479	137	134	3		

- Molecule 25 is a protein called Large ribosomal subunit protein bL27.

Mol	Chain	Residues	Atoms					AltConf	Trace
25	v	78	Total	C	N	O	S	0	0
			586	362	116	107	1		

- Molecule 26 is a protein called Large ribosomal subunit protein bL28.

Mol	Chain	Residues	Atoms					AltConf	Trace
26	w	77	Total	C	N	O	S	0	0
			625	388	129	106	2		

- Molecule 27 is a protein called Large ribosomal subunit protein uL29.

Mol	Chain	Residues	Atoms					AltConf	Trace
			Total	C	N	O	S		
27	x	62	501	308	98	94	1	0	0

- Molecule 28 is a protein called Large ribosomal subunit protein uL30.

Mol	Chain	Residues	Atoms					AltConf	Trace
			Total	C	N	O	S		
28	y	57	444	278	86	78	2	0	0

- Molecule 29 is a protein called Large ribosomal subunit protein bL32.

Mol	Chain	Residues	Atoms					AltConf	Trace
			Total	C	N	O	S		
29	z	56	444	269	94	80	1	0	0

- Molecule 30 is ZINC ION (three-letter code: ZN) (formula: Zn).

Mol	Chain	Residues	Atoms		AltConf
			Total	Zn	
30	3	1	1	1	0

- Molecule 31 is Pentacycline (three-letter code: P8F) (formula: C₂₉H₃₀FN₃O₇) (labeled as "Ligand of Interest" by depositor).

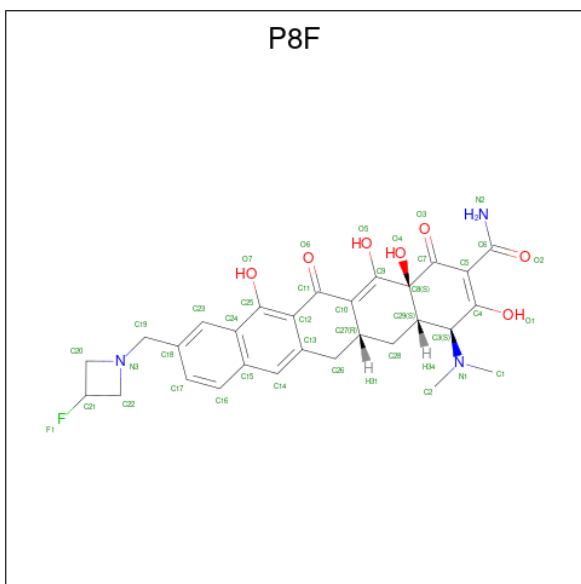

Mol	Chain	Residues	Atoms					AltConf
			Total	C	F	N	O	
31	a	1	40	29	1	3	7	0

Continued on next page...

Continued from previous page...

Mol	Chain	Residues	Atoms					AltConf
			Total	C	F	N	O	
31	a	1	40	29	1	3	7	0

- Molecule 32 is TIAMULIN (three-letter code: MUL) (formula: $C_{28}H_{47}NO_4S$) (labeled as "Ligand of Interest" by depositor).

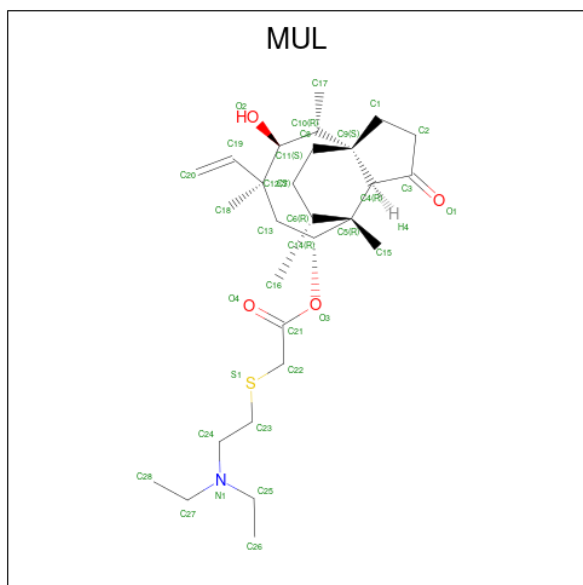

Mol	Chain	Residues	Atoms					AltConf
			Total	C	N	O	S	
32	a	1	34	28	1	4	1	0

- Molecule 33 is MAGNESIUM ION (three-letter code: MG) (formula: Mg).

Mol	Chain	Residues	Atoms		AltConf
			Total	Mg	
33	a	210	210	210	0
33	b	2	2	2	0
33	c	3	3	3	0
33	d	1	1	1	0
33	p	1	1	1	0
33	v	1	1	1	0
33	z	1	1	1	0

- Molecule 34 is POTASSIUM ION (three-letter code: K) (formula: K).

Mol	Chain	Residues	Atoms	AltConf
34	a	76	Total K 76 76	0
34	c	4	Total K 4 4	0
34	e	1	Total K 1 1	0
34	t	1	Total K 1 1	0
34	v	1	Total K 1 1	0

- Molecule 35 is water.

Mol	Chain	Residues	Atoms	AltConf
35	0	5	Total O 5 5	0
35	1	33	Total O 33 33	0
35	2	28	Total O 28 28	0
35	3	7	Total O 7 7	0
35	a	5631	Total O 5631 5631	0
35	b	79	Total O 79 79	0
35	c	118	Total O 118 118	0
35	d	84	Total O 84 84	0
35	e	56	Total O 56 56	0
35	g	1	Total O 1 1	0
35	i	34	Total O 34 34	0
35	j	31	Total O 31 31	0
35	k	63	Total O 63 63	0
35	l	56	Total O 56 56	0

Continued on next page...

Continued from previous page...

Mol	Chain	Residues	Atoms		AltConf
35	m	41	Total 41	O 41	0
35	n	2	Total 2	O 2	0
35	o	32	Total 32	O 32	0
35	p	60	Total 60	O 60	0
35	q	29	Total 29	O 29	0
35	r	41	Total 41	O 41	0
35	s	15	Total 15	O 15	0
35	t	11	Total 11	O 11	0
35	u	12	Total 12	O 12	0
35	v	26	Total 26	O 26	0
35	w	23	Total 23	O 23	0
35	x	6	Total 6	O 6	0
35	y	9	Total 9	O 9	0
35	z	37	Total 37	O 37	0

3 Residue-property plots [i](#)

These plots are drawn for all protein, RNA, DNA and oligosaccharide chains in the entry. The first graphic for a chain summarises the proportions of the various outlier classes displayed in the second graphic. The second graphic shows the sequence view annotated by issues in geometry and atom inclusion in map density. Residues are color-coded according to the number of geometric quality criteria for which they contain at least one outlier: green = 0, yellow = 1, orange = 2 and red = 3 or more. A red diamond above a residue indicates a poor fit to the EM map for this residue (all-atom inclusion < 40%). Stretches of 2 or more consecutive residues without any outlier are shown as a green connector. Residues present in the sample, but not in the model, are shown in grey.

- Molecule 1: Large ribosomal subunit protein bL33

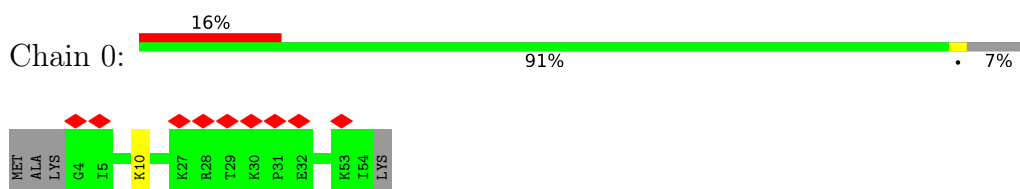

- Molecule 2: Large ribosomal subunit protein bL34

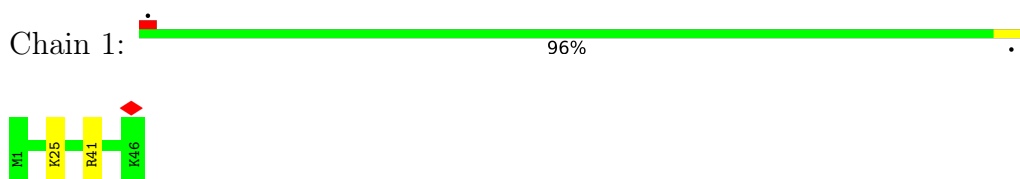

- Molecule 3: Large ribosomal subunit protein bL35

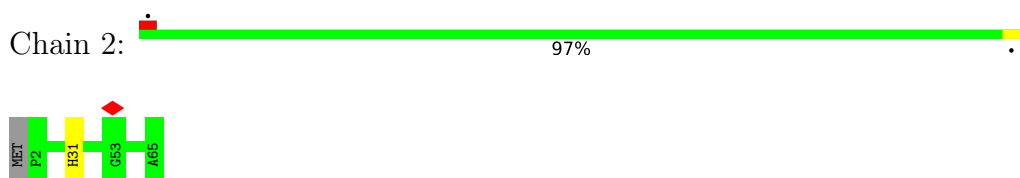

- Molecule 4: Large ribosomal subunit protein bL36A

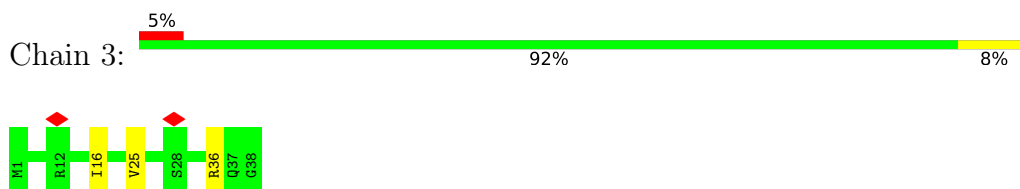

- Molecule 5: 23S rRNA

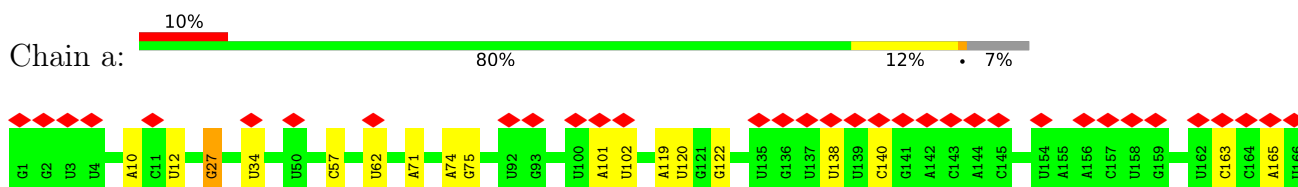

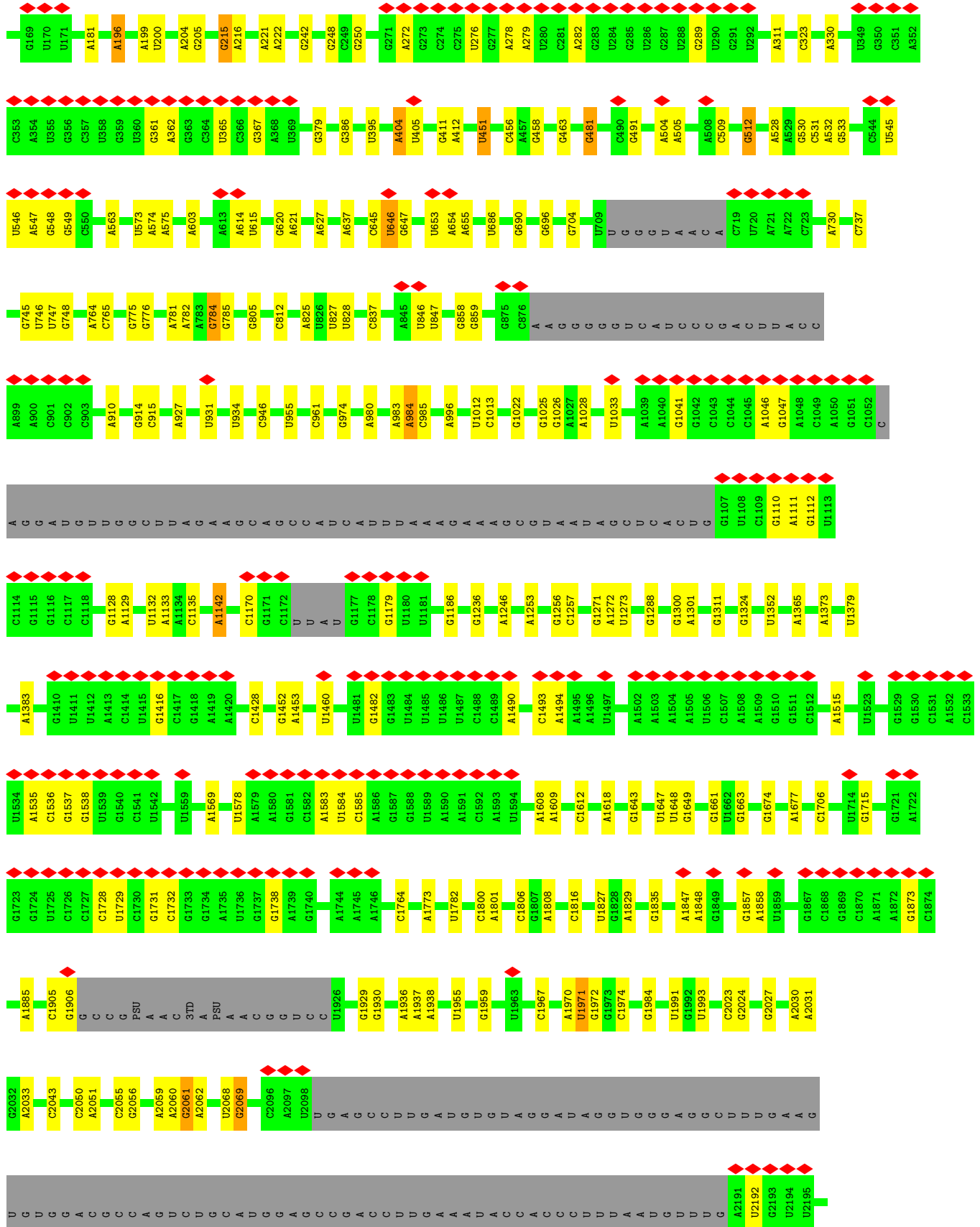

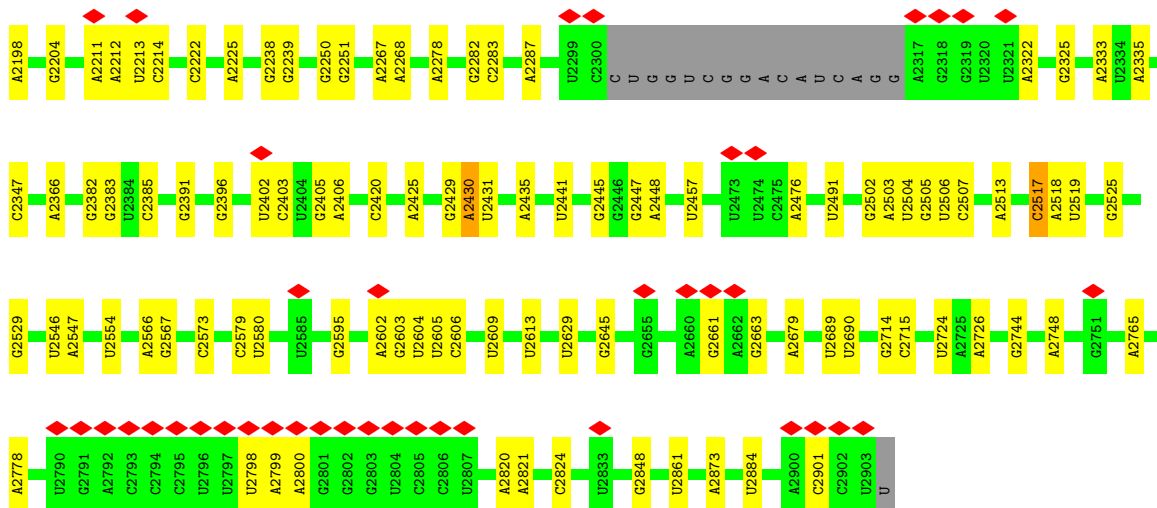

• Molecule 6: 5S rRNA



• Molecule 7: Large ribosomal subunit protein uL2

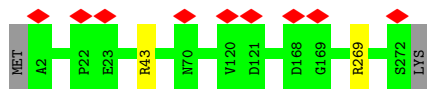

• Molecule 8: Large ribosomal subunit protein uL3

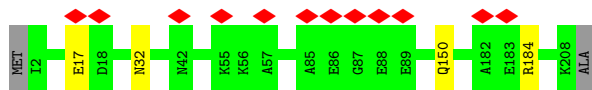

• Molecule 9: Large ribosomal subunit protein uL4



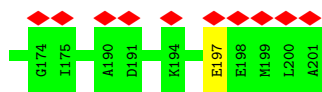

- Molecule 10: Large ribosomal subunit protein uL6

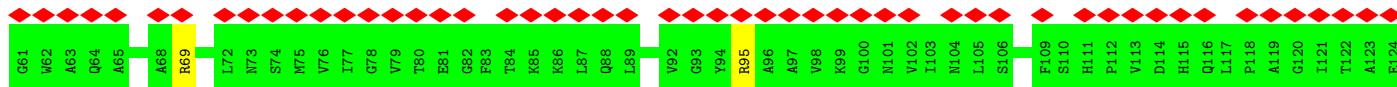
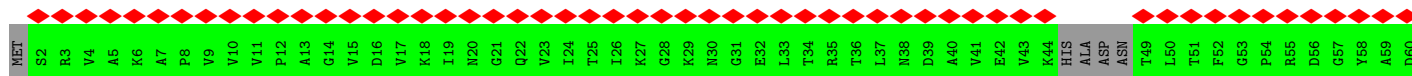
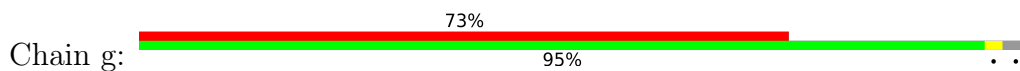

- Molecule 11: Large ribosomal subunit protein bL9

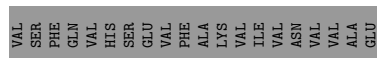
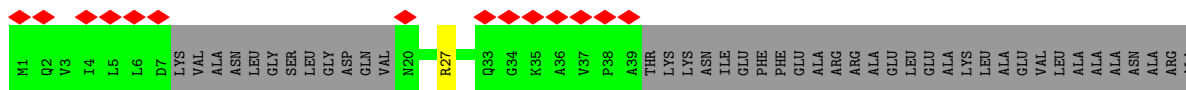

- Molecule 12: Large ribosomal subunit protein uL13

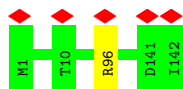

- Molecule 13: Large ribosomal subunit protein uL14

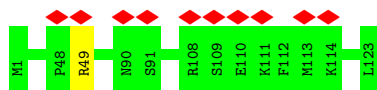

- Molecule 14: 50S ribosomal protein L15



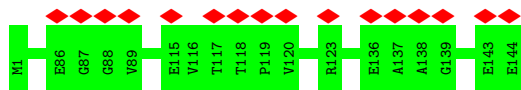

- Molecule 15: Large ribosomal subunit protein uL16

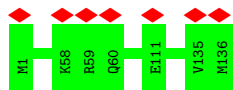

- Molecule 16: Large ribosomal subunit protein bL17

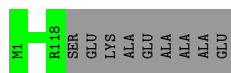

- Molecule 17: Large ribosomal subunit protein uL18

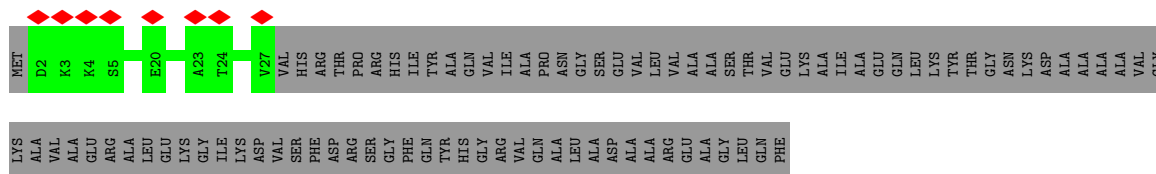

- Molecule 18: Large ribosomal subunit protein bL19

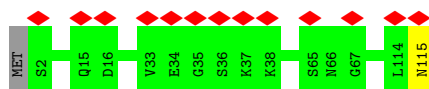

- Molecule 19: Large ribosomal subunit protein bL20

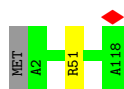

- Molecule 20: Large ribosomal subunit protein bL21

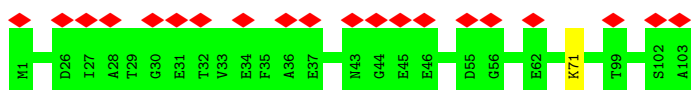

- Molecule 21: Large ribosomal subunit protein uL22

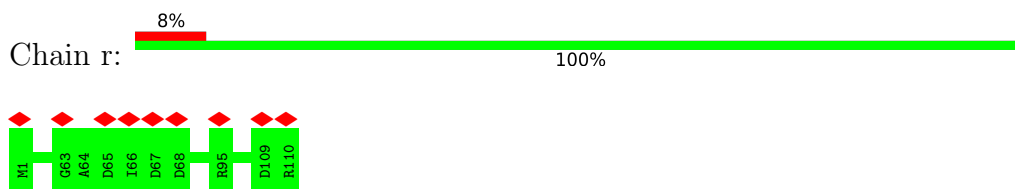

- Molecule 22: Large ribosomal subunit protein uL23

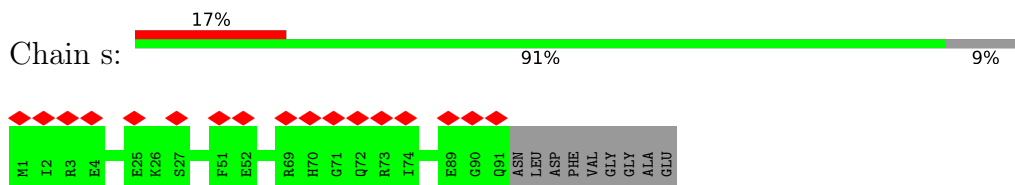

- Molecule 23: Large ribosomal subunit protein uL24

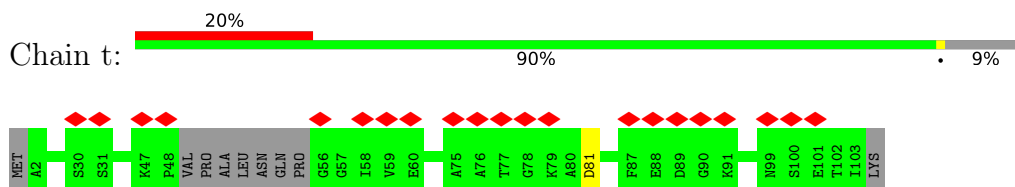

- Molecule 24: 50S ribosomal protein L25

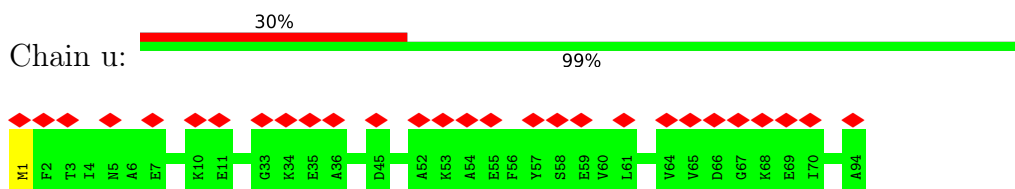

- Molecule 25: Large ribosomal subunit protein bL27

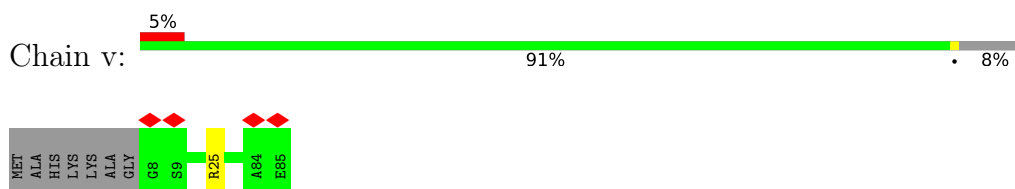

- Molecule 26: Large ribosomal subunit protein bL28

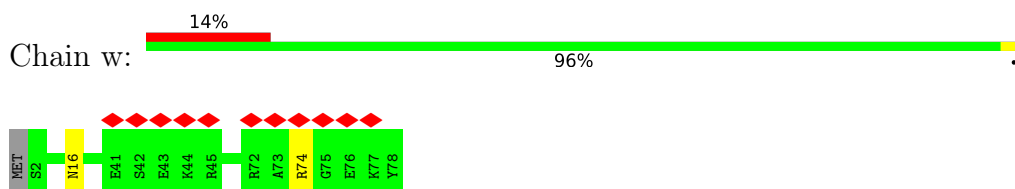

- Molecule 27: Large ribosomal subunit protein uL29





- Molecule 28: Large ribosomal subunit protein uL30

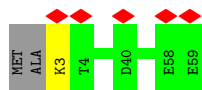

- Molecule 29: Large ribosomal subunit protein bL32

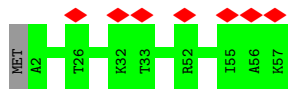

4 Experimental information

Property	Value	Source
EM reconstruction method	SINGLE PARTICLE	Depositor
Imposed symmetry	POINT, Not provided	
Number of particles used	1301160	Depositor
Resolution determination method	FSC 0.143 CUT-OFF	Depositor
CTF correction method	PHASE FLIPPING AND AMPLITUDE CORRECTION	Depositor
Microscope	FEI TITAN KRIOS	Depositor
Voltage (kV)	300	Depositor
Electron dose ($e^-/\text{\AA}^2$)	45	Depositor
Minimum defocus (nm)	400	Depositor
Maximum defocus (nm)	1600	Depositor
Magnification	Not provided	
Image detector	GATAN K3 BIOQUANTUM (6k x 4k)	Depositor
Maximum map value	0.357	Depositor
Minimum map value	-0.135	Depositor
Average map value	0.000	Depositor
Map value standard deviation	0.006	Depositor
Recommended contour level	0.0309	Depositor
Map size (Å)	363.36002, 363.36002, 363.36002	wwPDB
Map dimensions	480, 480, 480	wwPDB
Map angles (°)	90.0, 90.0, 90.0	wwPDB
Pixel spacing (Å)	0.757, 0.757, 0.757	Depositor

5 Model quality [i](#)

5.1 Standard geometry [i](#)

Bond lengths and bond angles in the following residue types are not validated in this section: OMG, 5MC, 1MG, 4D4, ZN, MS6, K, PSU, MEQ, MUL, 2MG, 6MZ, MG, OMU, H2U, 2MA, G7M, 5MU, P8F, OMC

The Z score for a bond length (or angle) is the number of standard deviations the observed value is removed from the expected value. A bond length (or angle) with $|Z| > 5$ is considered an outlier worth inspection. RMSZ is the root-mean-square of all Z scores of the bond lengths (or angles).

Mol	Chain	Bond lengths		Bond angles	
		RMSZ	# Z >5	RMSZ	# Z >5
1	0	0.31	0/424	0.65	0/565
2	1	0.33	0/380	0.75	0/498
3	2	0.32	0/513	0.68	0/676
4	3	0.29	0/303	0.74	0/397
5	a	0.50	0/64138	1.15	99/100046 (0.1%)
6	b	0.53	0/1352	1.19	2/2107 (0.1%)
7	c	0.31	0/2121	0.71	0/2852
8	d	0.30	0/1562	0.67	0/2102
9	e	0.30	0/1571	0.62	0/2113
10	g	0.31	0/1310	0.66	0/1769
11	h	0.36	0/206	0.78	1/277 (0.4%)
12	i	0.30	0/1152	0.64	0/1551
13	j	0.30	0/955	0.71	0/1279
14	k	0.33	0/1062	0.65	0/1413
15	l	0.29	0/1073	0.66	0/1433
16	m	0.30	0/958	0.65	0/1281
17	n	0.28	0/212	0.72	0/278
18	o	0.31	0/929	0.69	0/1242
19	p	0.30	0/960	0.68	0/1278
20	q	0.32	0/829	0.68	0/1107
21	r	0.31	0/864	0.66	0/1156
22	s	0.27	0/728	0.60	0/972
23	t	0.29	0/733	0.66	0/973
24	u	0.29	0/766	0.65	0/1025
25	v	0.33	0/593	0.67	0/785
26	w	0.32	0/635	0.71	0/848
27	x	0.28	0/502	0.55	0/667
28	y	0.30	0/448	0.65	0/598
29	z	0.34	0/450	0.69	0/599
All	All	0.46	0/87729	1.06	102/131887 (0.1%)

Chiral center outliers are detected by calculating the chiral volume of a chiral center and verifying if the center is modelled as a planar moiety or with the opposite hand. A planarity outlier is detected by checking planarity of atoms in a peptide group, atoms in a mainchain group or atoms of a sidechain that are expected to be planar.

Mol	Chain	#Chirality outliers	#Planarity outliers
2	1	0	1
4	3	0	1
5	a	0	8
7	c	0	1
8	d	0	1
9	e	0	1
10	g	0	2
12	i	0	1
19	p	0	1
25	v	0	1
26	w	0	2
27	x	0	1
All	All	0	21

There are no bond length outliers.

The worst 5 of 102 bond angle outliers are listed below:

Mol	Chain	Res	Type	Atoms	Z	Observed(°)	Ideal(°)
5	a	574	A	O5'-P-OP1	-18.38	88.65	110.70
5	a	2430	A	O5'-P-OP2	-16.99	90.31	110.70
5	a	574	A	O5'-P-OP2	16.68	130.71	110.70
6	b	99	A	O5'-P-OP1	-15.06	92.14	105.70
5	a	512	G	O4'-C1'-N9	11.98	117.78	108.20

There are no chirality outliers.

5 of 21 planarity outliers are listed below:

Mol	Chain	Res	Type	Group
2	1	41	ARG	Sidechain
4	3	36	ARG	Sidechain
5	a	250	G	Sidechain
5	a	27	G	Sidechain
5	a	463	G	Sidechain

5.2 Too-close contacts [i](#)

In the following table, the Non-H and H(model) columns list the number of non-hydrogen atoms and hydrogen atoms in the chain respectively. The H(added) column lists the number of hydrogen atoms added and optimized by MolProbity. The Clashes column lists the number of clashes within the asymmetric unit, whereas Symm-Clashes lists symmetry-related clashes.

Mol	Chain	Non-H	H(model)	H(added)	Clashes	Symm-Clashes
1	0	417	0	451	0	0
2	1	377	0	418	0	0
3	2	504	0	572	0	0
4	3	302	0	340	1	0
5	a	57720	0	29030	0	0
6	b	1209	0	609	0	0
7	c	2082	0	2153	0	0
8	d	1552	0	1601	0	0
9	e	1552	0	1619	0	0
10	g	1292	0	1348	0	0
11	h	204	0	219	0	0
12	i	1129	0	1162	0	0
13	j	946	0	1023	0	0
14	k	1053	0	1129	0	0
15	l	1075	0	1145	0	0
16	m	945	0	989	0	0
17	n	213	0	242	0	0
18	o	917	0	962	0	0
19	p	947	0	1019	0	0
20	q	816	0	839	0	0
21	r	857	0	922	0	0
22	s	722	0	790	0	0
23	t	728	0	776	0	0
24	u	753	0	780	0	0
25	v	586	0	596	0	0
26	w	625	0	652	0	0
27	x	501	0	531	0	0
28	y	444	0	483	0	0
29	z	444	0	458	0	0
30	3	1	0	0	0	0
31	a	80	0	0	0	0
32	a	34	0	47	0	0
33	a	210	0	0	0	0
33	b	2	0	0	0	0
33	c	3	0	0	0	0
33	d	1	0	0	0	0
33	p	1	0	0	0	0

Continued on next page...

Continued from previous page...

Mol	Chain	Non-H	H(model)	H(added)	Clashes	Symm-Clashes
33	v	1	0	0	0	0
33	z	1	0	0	0	0
34	a	76	0	0	0	0
34	c	4	0	0	0	0
34	e	1	0	0	0	0
34	t	1	0	0	0	0
34	v	1	0	0	0	0
35	0	5	0	0	0	0
35	1	33	0	0	0	0
35	2	28	0	0	0	0
35	3	7	0	0	0	0
35	a	5631	0	0	0	0
35	b	79	0	0	0	0
35	c	118	0	0	0	0
35	d	84	0	0	0	0
35	e	56	0	0	0	0
35	g	1	0	0	0	0
35	i	34	0	0	0	0
35	j	31	0	0	0	0
35	k	63	0	0	0	0
35	l	56	0	0	0	0
35	m	41	0	0	0	0
35	n	2	0	0	0	0
35	o	32	0	0	0	0
35	p	60	0	0	0	0
35	q	29	0	0	0	0
35	r	41	0	0	0	0
35	s	15	0	0	0	0
35	t	11	0	0	0	0
35	u	12	0	0	0	0
35	v	26	0	0	0	0
35	w	23	0	0	0	0
35	x	6	0	0	0	0
35	y	9	0	0	0	0
35	z	37	0	0	0	0
All	All	87899	0	52905	1	0

The all-atom clashscore is defined as the number of clashes found per 1000 atoms (including hydrogen atoms). The all-atom clashscore for this structure is 1.

All (1) close contacts within the same asymmetric unit are listed below, sorted by their clash magnitude.

Atom-1	Atom-2	Interatomic distance (Å)	Clash overlap (Å)
4:3:16:ILE:HD13	4:3:25:VAL:HG22	1.99	0.44

There are no symmetry-related clashes.

5.3 Torsion angles [i](#)

5.3.1 Protein backbone [i](#)

In the following table, the Percentiles column shows the percent Ramachandran outliers of the chain as a percentile score with respect to all PDB entries followed by that with respect to all EM entries.

The Analysed column shows the number of residues for which the backbone conformation was analysed, and the total number of residues.

Mol	Chain	Analysed	Favoured	Allowed	Outliers	Percentiles	
1	0	49/55 (89%)	49 (100%)	0	0	100	100
2	1	44/46 (96%)	44 (100%)	0	0	100	100
3	2	62/65 (95%)	60 (97%)	2 (3%)	0	100	100
4	3	36/38 (95%)	36 (100%)	0	0	100	100
7	c	269/273 (98%)	260 (97%)	9 (3%)	0	100	100
8	d	204/209 (98%)	198 (97%)	6 (3%)	0	100	100
9	e	199/201 (99%)	193 (97%)	6 (3%)	0	100	100
10	g	168/177 (95%)	159 (95%)	9 (5%)	0	100	100
11	h	23/149 (15%)	22 (96%)	1 (4%)	0	100	100
12	i	140/142 (99%)	140 (100%)	0	0	100	100
13	j	121/123 (98%)	119 (98%)	2 (2%)	0	100	100
14	k	142/144 (99%)	138 (97%)	4 (3%)	0	100	100
15	l	132/136 (97%)	129 (98%)	3 (2%)	0	100	100
16	m	116/127 (91%)	113 (97%)	3 (3%)	0	100	100
17	n	24/117 (20%)	24 (100%)	0	0	100	100
18	o	112/115 (97%)	108 (96%)	4 (4%)	0	100	100
19	p	115/118 (98%)	114 (99%)	1 (1%)	0	100	100
20	q	101/103 (98%)	99 (98%)	2 (2%)	0	100	100
21	r	108/110 (98%)	107 (99%)	1 (1%)	0	100	100

Continued on next page...

Continued from previous page...

Mol	Chain	Analysed	Favoured	Allowed	Outliers	Percentiles	
22	s	89/100 (89%)	87 (98%)	2 (2%)	0	100	100
23	t	91/104 (88%)	90 (99%)	1 (1%)	0	100	100
24	u	92/94 (98%)	90 (98%)	2 (2%)	0	100	100
25	v	76/85 (89%)	74 (97%)	2 (3%)	0	100	100
26	w	75/78 (96%)	75 (100%)	0	0	100	100
27	x	60/63 (95%)	59 (98%)	1 (2%)	0	100	100
28	y	55/59 (93%)	54 (98%)	1 (2%)	0	100	100
29	z	54/57 (95%)	52 (96%)	2 (4%)	0	100	100
All	All	2757/3088 (89%)	2693 (98%)	64 (2%)	0	100	100

There are no Ramachandran outliers to report.

5.3.2 Protein sidechains [i](#)

In the following table, the Percentiles column shows the percent sidechain outliers of the chain as a percentile score with respect to all PDB entries followed by that with respect to all EM entries.

The Analysed column shows the number of residues for which the sidechain conformation was analysed, and the total number of residues.

Mol	Chain	Analysed	Rotameric	Outliers	Percentiles	
1	0	46/49 (94%)	45 (98%)	1 (2%)	52	27
2	1	38/38 (100%)	37 (97%)	1 (3%)	46	21
3	2	51/52 (98%)	50 (98%)	1 (2%)	55	32
4	3	34/34 (100%)	34 (100%)	0	100	100
7	c	216/218 (99%)	215 (100%)	1 (0%)	88	81
8	d	162/163 (99%)	160 (99%)	2 (1%)	71	53
9	e	165/165 (100%)	163 (99%)	2 (1%)	71	53
10	g	134/138 (97%)	133 (99%)	1 (1%)	84	73
11	h	21/114 (18%)	21 (100%)	0	100	100
12	i	116/116 (100%)	116 (100%)	0	100	100
13	j	104/104 (100%)	103 (99%)	1 (1%)	76	62
14	k	103/103 (100%)	103 (100%)	0	100	100
15	l	107/107 (100%)	107 (100%)	0	100	100

Continued on next page...

Continued from previous page...

Mol	Chain	Analysed	Rotameric	Outliers	Percentiles	
16	m	98/103 (95%)	98 (100%)	0	100	100
17	n	21/87 (24%)	21 (100%)	0	100	100
18	o	99/100 (99%)	98 (99%)	1 (1%)	76	62
19	p	89/90 (99%)	89 (100%)	0	100	100
20	q	84/84 (100%)	83 (99%)	1 (1%)	71	53
21	r	93/93 (100%)	93 (100%)	0	100	100
22	s	78/84 (93%)	78 (100%)	0	100	100
23	t	77/85 (91%)	76 (99%)	1 (1%)	69	50
24	u	78/78 (100%)	77 (99%)	1 (1%)	69	50
25	v	58/63 (92%)	58 (100%)	0	100	100
26	w	67/68 (98%)	67 (100%)	0	100	100
27	x	54/55 (98%)	54 (100%)	0	100	100
28	y	48/49 (98%)	47 (98%)	1 (2%)	53	29
29	z	47/48 (98%)	47 (100%)	0	100	100
All	All	2288/2488 (92%)	2273 (99%)	15 (1%)	84	73

5 of 15 residues with a non-rotameric sidechain are listed below:

Mol	Chain	Res	Type
9	e	197	GLU
24	u	1	MET
10	g	95	ARG
28	y	3	LYS
20	q	71	LYS

Sometimes sidechains can be flipped to improve hydrogen bonding and reduce clashes. All (3) such sidechains are listed below:

Mol	Chain	Res	Type
19	p	44	GLN
26	w	36	HIS
27	x	58	ASN

5.3.3 RNA [i](#)

Mol	Chain	Analysed	Backbone Outliers	Pucker Outliers
5	a	2676/2904 (92%)	263 (9%)	0
6	b	54/120 (45%)	5 (9%)	0
All	All	2730/3024 (90%)	268 (9%)	0

5 of 268 RNA backbone outliers are listed below:

Mol	Chain	Res	Type
5	a	10	A
5	a	34	U
5	a	71	A
5	a	74	A
5	a	75	G

There are no RNA pucker outliers to report.

5.4 Non-standard residues in protein, DNA, RNA chains [i](#)

23 non-standard protein/DNA/RNA residues are modelled in this entry.

In the following table, the Counts columns list the number of bonds (or angles) for which Mogul statistics could be retrieved, the number of bonds (or angles) that are observed in the model and the number of bonds (or angles) that are defined in the Chemical Component Dictionary. The Link column lists molecule types, if any, to which the group is linked. The Z score for a bond length (or angle) is the number of standard deviations the observed value is removed from the expected value. A bond length (or angle) with $|Z| > 2$ is considered an outlier worth inspection. RMSZ is the root-mean-square of all Z scores of the bond lengths (or angles).

Mol	Type	Chain	Res	Link	Bond lengths			Bond angles		
					Counts	RMSZ	# Z > 2	Counts	RMSZ	# Z > 2
5	2MA	a	2503	34,33,5	17,25,26	1.01	2 (11%)	17,37,40	0.95	1 (5%)
5	2MG	a	2445	5	18,26,27	1.00	1 (5%)	16,38,41	0.86	0
5	PSU	a	2605	5	18,21,22	0.95	1 (5%)	22,30,33	0.91	0
5	5MC	a	1962	5	18,22,23	0.33	0	26,32,35	0.65	0
5	OMC	a	2498	33,5	19,22,23	0.24	0	26,31,34	0.58	0
5	PSU	a	2580	34,5	18,21,22	1.04	1 (5%)	22,30,33	0.78	1 (4%)
5	5MU	a	1939	34,5	19,22,23	0.36	0	28,32,35	0.44	0
5	OMG	a	2251	34,5	18,26,27	1.00	1 (5%)	19,38,41	0.74	0
5	G7M	a	2069	5	20,26,27	1.01	1 (5%)	17,39,42	0.68	0
5	5MU	a	747	5	19,22,23	0.32	0	28,32,35	0.56	0
8	MEQ	d	150	8	8,9,10	0.56	0	5,10,12	1.51	2 (40%)
5	H2U	a	2449	5	18,21,22	0.58	0	21,30,33	0.76	0
5	PSU	a	746	33,5	18,21,22	1.02	1 (5%)	22,30,33	0.66	0

Mol	Type	Chain	Res	Link	Bond lengths			Bond angles		
					Counts	RMSZ	# Z > 2	Counts	RMSZ	# Z > 2
5	6MZ	a	2030	5	18,25,26	0.73	0	16,36,39	1.02	1 (6%)
5	2MG	a	1835	5	18,26,27	1.03	2 (11%)	16,38,41	0.77	1 (6%)
15	4D4	l	81	15	9,11,12	0.47	0	8,13,15	1.00	0
5	6MZ	a	1618	5	18,25,26	0.73	0	16,36,39	0.90	1 (6%)
5	PSU	a	955	5	18,21,22	0.93	1 (5%)	22,30,33	0.60	0
5	PSU	a	2504	34,5	18,21,22	0.91	1 (5%)	22,30,33	0.65	0
5	PSU	a	2457	5	18,21,22	1.00	1 (5%)	22,30,33	0.69	0
5	1MG	a	745	5	18,26,27	1.06	2 (11%)	19,39,42	0.51	0
5	OMU	a	2552	5	19,22,23	0.26	0	26,31,34	0.48	0
5	PSU	a	2604	5	18,21,22	0.97	1 (5%)	22,30,33	0.73	1 (4%)

In the following table, the Chirals column lists the number of chiral outliers, the number of chiral centers analysed, the number of these observed in the model and the number defined in the Chemical Component Dictionary. Similar counts are reported in the Torsion and Rings columns. '-' means no outliers of that kind were identified.

Mol	Type	Chain	Res	Link	Chirals	Torsions	Rings
5	2MA	a	2503	34,33,5	-	1/3/25/26	0/3/3/3
5	2MG	a	2445	5	-	0/5/27/28	0/3/3/3
5	PSU	a	2605	5	-	0/7/25/26	0/2/2/2
5	5MC	a	1962	5	-	0/7/25/26	0/2/2/2
5	OMC	a	2498	33,5	-	0/9/27/28	0/2/2/2
5	PSU	a	2580	34,5	-	0/7/25/26	0/2/2/2
5	5MU	a	1939	34,5	-	0/7/25/26	0/2/2/2
5	OMG	a	2251	34,5	-	0/5/27/28	0/3/3/3
5	G7M	a	2069	5	-	2/3/25/26	0/3/3/3
5	5MU	a	747	5	-	0/7/25/26	0/2/2/2
8	MEQ	d	150	8	-	2/8/9/11	-
5	H2U	a	2449	5	-	0/7/38/39	0/2/2/2
5	PSU	a	746	33,5	-	1/7/25/26	0/2/2/2
5	6MZ	a	2030	5	-	2/5/27/28	0/3/3/3
5	2MG	a	1835	5	-	0/5/27/28	0/3/3/3
15	4D4	l	81	15	-	1/11/12/14	-
5	6MZ	a	1618	5	-	0/5/27/28	0/3/3/3
5	PSU	a	955	5	-	0/7/25/26	0/2/2/2
5	PSU	a	2504	34,5	-	0/7/25/26	0/2/2/2
5	PSU	a	2457	5	-	0/7/25/26	0/2/2/2
5	1MG	a	745	5	-	0/3/25/26	0/3/3/3
5	OMU	a	2552	5	-	1/9/27/28	0/2/2/2
5	PSU	a	2604	5	-	0/7/25/26	0/2/2/2

The worst 5 of 16 bond length outliers are listed below:

Mol	Chain	Res	Type	Atoms	Z	Observed(Å)	Ideal(Å)
5	a	2580	PSU	C6-C5	4.12	1.40	1.35
5	a	2457	PSU	C6-C5	4.03	1.40	1.35
5	a	746	PSU	C6-C5	3.85	1.39	1.35
5	a	2605	PSU	C6-C5	3.73	1.39	1.35
5	a	2604	PSU	C6-C5	3.73	1.39	1.35

The worst 5 of 8 bond angle outliers are listed below:

Mol	Chain	Res	Type	Atoms	Z	Observed(°)	Ideal(°)
5	a	2030	6MZ	C2-N1-C6	2.90	119.08	116.59
5	a	2503	2MA	CM2-C2-N1	2.74	122.33	116.23
5	a	1618	6MZ	C2-N1-C6	2.58	118.81	116.59
5	a	2604	PSU	C2'-C3'-C4'	-2.34	98.10	102.64
8	d	150	MEQ	OE1-CD-CG	-2.25	117.91	122.02

There are no chirality outliers.

5 of 10 torsion outliers are listed below:

Mol	Chain	Res	Type	Atoms
5	a	2030	6MZ	O4'-C4'-C5'-O5'
8	d	150	MEQ	OE1-CD-CG-CB
8	d	150	MEQ	NE2-CD-CG-CB
5	a	2030	6MZ	C3'-C4'-C5'-O5'
5	a	2069	G7M	C4'-C5'-O5'-P

There are no ring outliers.

No monomer is involved in short contacts.

5.5 Carbohydrates [i](#)

There are no monosaccharides in this entry.

5.6 Ligand geometry [i](#)

Of 306 ligands modelled in this entry, 303 are monoatomic - leaving 3 for Mogul analysis.

In the following table, the Counts columns list the number of bonds (or angles) for which Mogul statistics could be retrieved, the number of bonds (or angles) that are observed in the model and the number of bonds (or angles) that are defined in the Chemical Component Dictionary. The Link column lists molecule types, if any, to which the group is linked. The Z score for a bond

length (or angle) is the number of standard deviations the observed value is removed from the expected value. A bond length (or angle) with $|Z| > 2$ is considered an outlier worth inspection. RMSZ is the root-mean-square of all Z scores of the bond lengths (or angles).

Mol	Type	Chain	Res	Link	Bond lengths			Bond angles		
					Counts	RMSZ	# Z > 2	Counts	RMSZ	# Z > 2
32	MUL	a	3003	-	36,36,36	0.66	0	54,55,55	0.95	4 (7%)
31	P8F	a	3002	33	42,45,45	0.65	0	48,72,72	0.74	2 (4%)
31	P8F	a	3001	33	42,45,45	0.64	0	48,72,72	0.61	0

In the following table, the Chirals column lists the number of chiral outliers, the number of chiral centers analysed, the number of these observed in the model and the number defined in the Chemical Component Dictionary. Similar counts are reported in the Torsion and Rings columns. '2' means no outliers of that kind were identified.

Mol	Type	Chain	Res	Link	Chirals	Torsions	Rings
32	MUL	a	3003	-	-	0/18/79/79	0/3/3/3
31	P8F	a	3002	33	-	0/12/78/78	0/6/6/6
31	P8F	a	3001	33	-	1/12/78/78	0/6/6/6

There are no bond length outliers.

The worst 5 of 6 bond angle outliers are listed below:

Mol	Chain	Res	Type	Atoms	Z	Observed(°)	Ideal(°)
32	a	3003	MUL	C12-C11-C10	2.75	117.28	114.58
31	a	3002	P8F	C11-C10-C9	2.53	120.80	118.80
32	a	3003	MUL	C18-C12-C13	-2.19	103.97	105.60
32	a	3003	MUL	C13-C12-C11	2.09	114.74	112.70
32	a	3003	MUL	C16-C6-C5	2.06	119.14	115.22

There are no chirality outliers.

All (1) torsion outliers are listed below:

Mol	Chain	Res	Type	Atoms
31	a	3001	P8F	C18-C19-N3-C20

There are no ring outliers.

No monomer is involved in short contacts.

The following is a two-dimensional graphical depiction of Mogul quality analysis of bond lengths, bond angles, torsion angles, and ring geometry for all instances of the Ligand of Interest. In addition, ligands with molecular weight > 250 and outliers as shown on the validation Tables will also be included. For torsion angles, if less than 5% of the Mogul distribution of torsion angles is

within 10 degrees of the torsion angle in question, then that torsion angle is considered an outlier. Any bond that is central to one or more torsion angles identified as an outlier by Mogul will be highlighted in the graph. For rings, the root-mean-square deviation (RMSD) between the ring in question and similar rings identified by Mogul is calculated over all ring torsion angles. If the average RMSD is greater than 60 degrees and the minimal RMSD between the ring in question and any Mogul-identified rings is also greater than 60 degrees, then that ring is considered an outlier. The outliers are highlighted in purple. The color gray indicates Mogul did not find sufficient equivalents in the CSD to analyse the geometry.

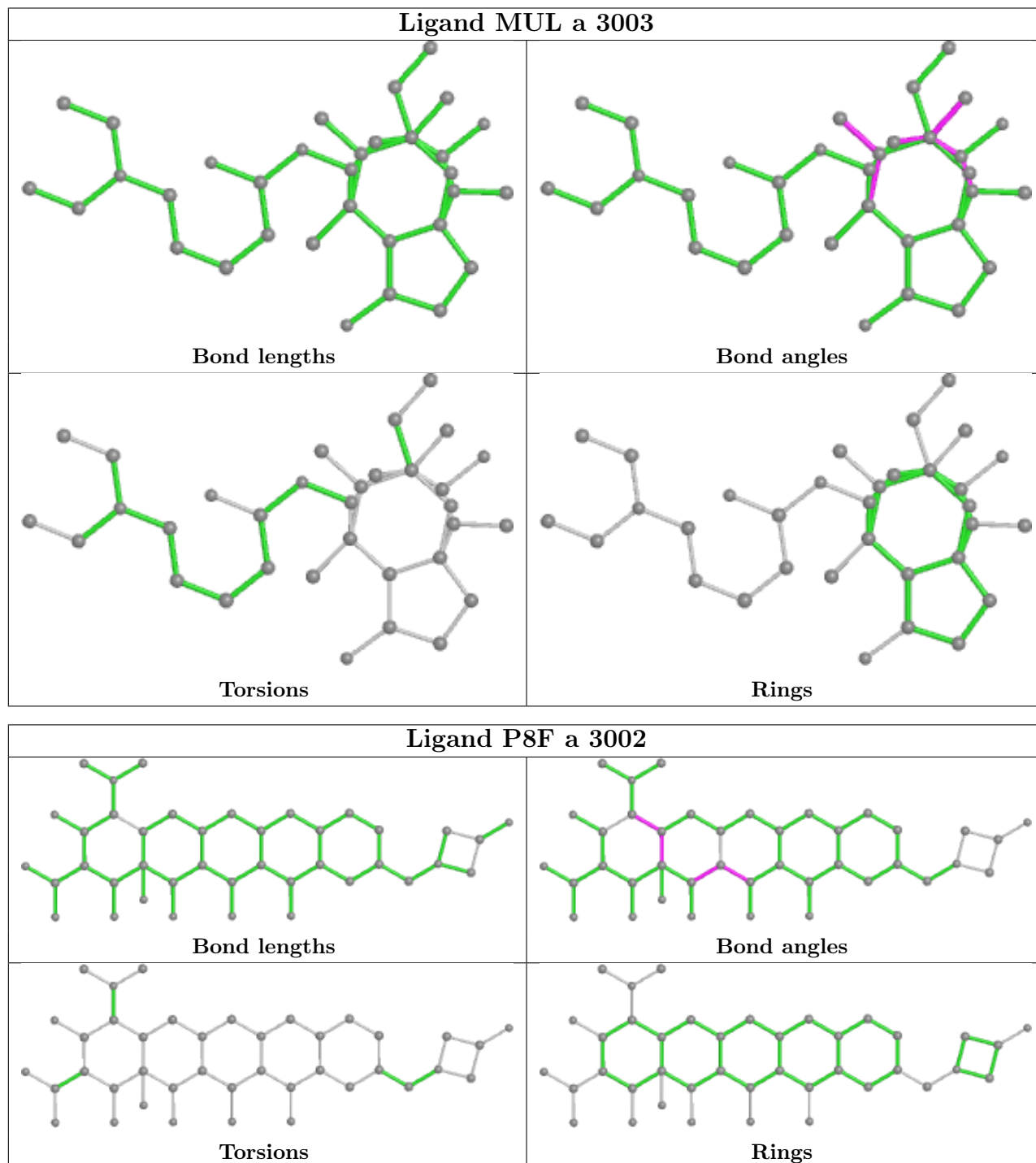

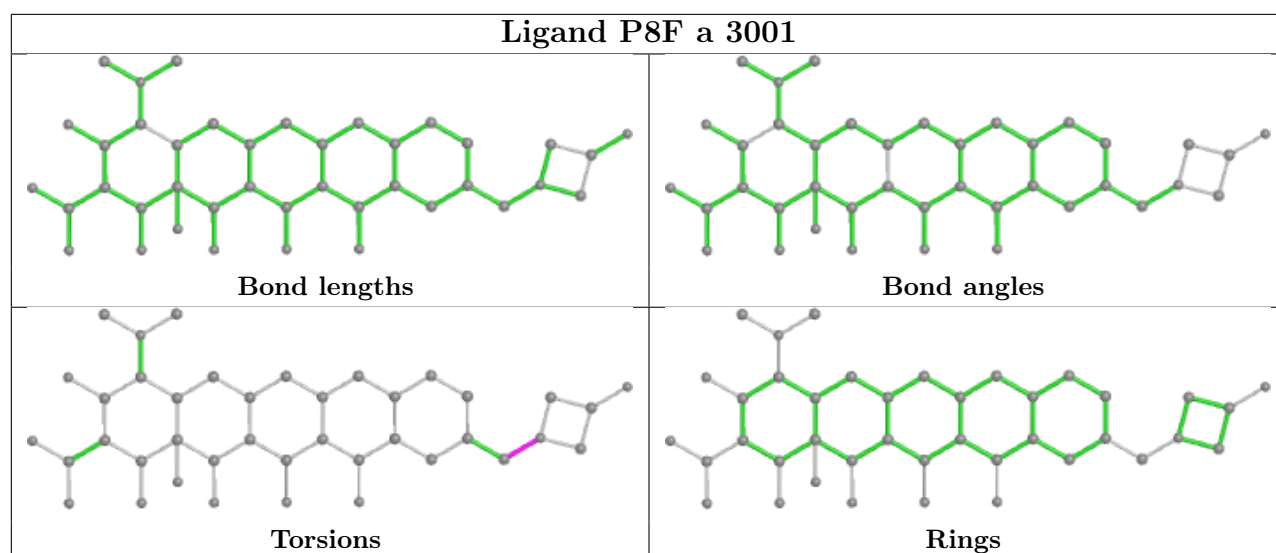

5.7 Other polymers [i](#)

There are no such residues in this entry.

5.8 Polymer linkage issues [i](#)

There are no chain breaks in this entry.

6 Map visualisation [i](#)

This section contains visualisations of the EMDB entry EMD-16652. These allow visual inspection of the internal detail of the map and identification of artifacts.

Images derived from a raw map, generated by summing the deposited half-maps, are presented below the corresponding image components of the primary map to allow further visual inspection and comparison with those of the primary map.

6.1 Orthogonal projections [i](#)

6.1.1 Primary map

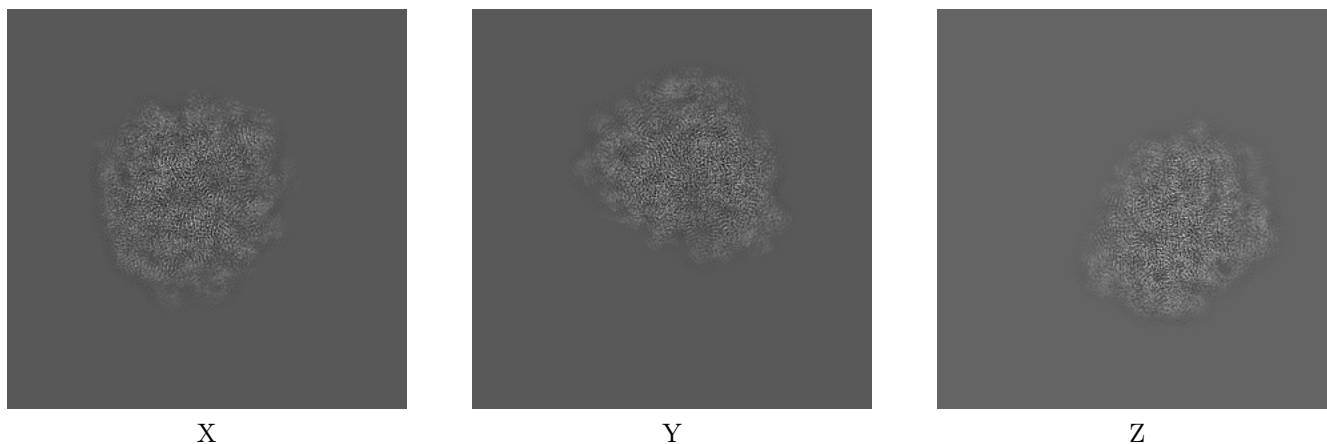

6.1.2 Raw map

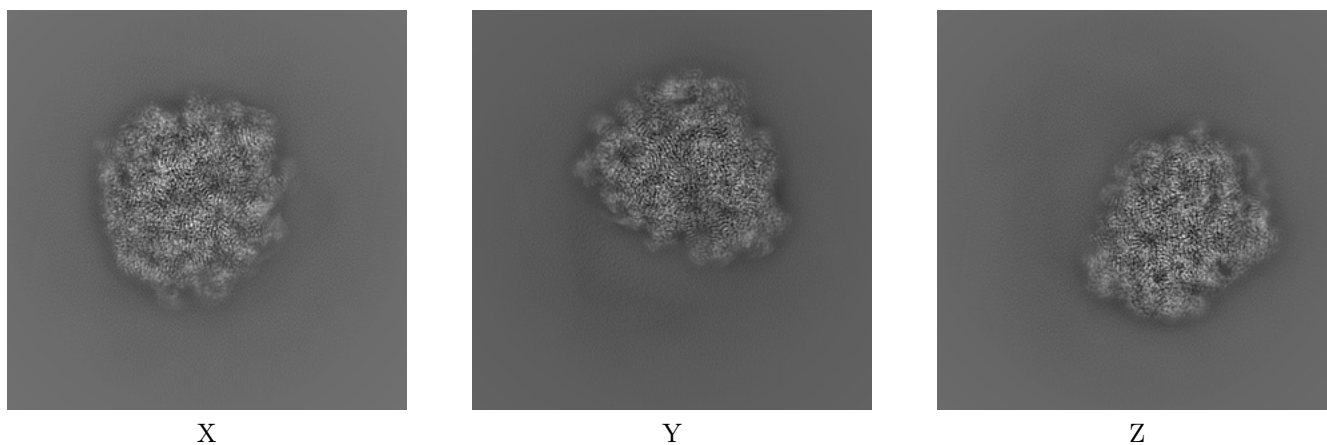

The images above show the map projected in three orthogonal directions.

6.2 Central slices [i](#)

6.2.1 Primary map

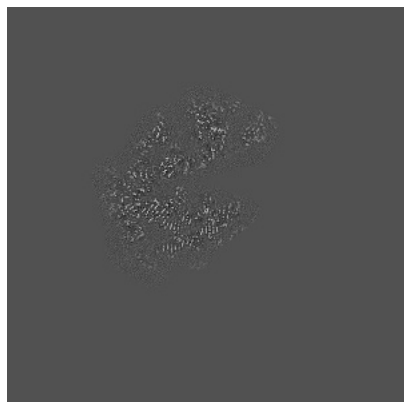

X Index: 240



Y Index: 240

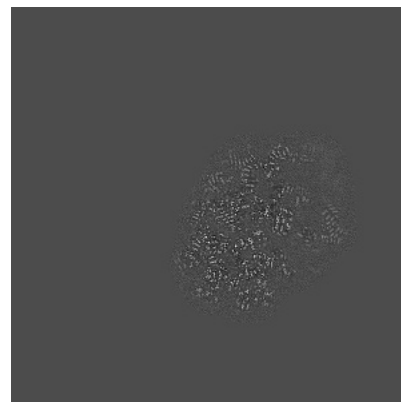

Z Index: 240

6.2.2 Raw map

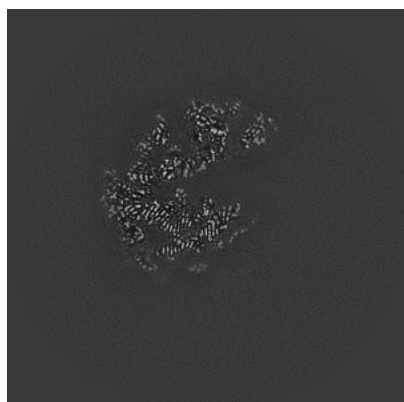

X Index: 240

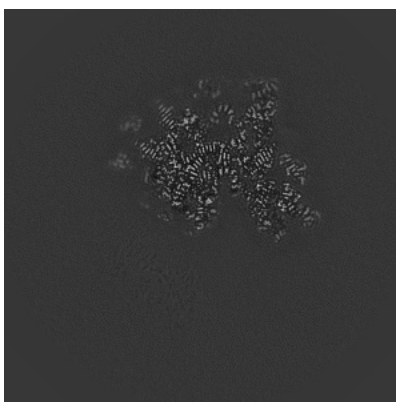

Y Index: 240

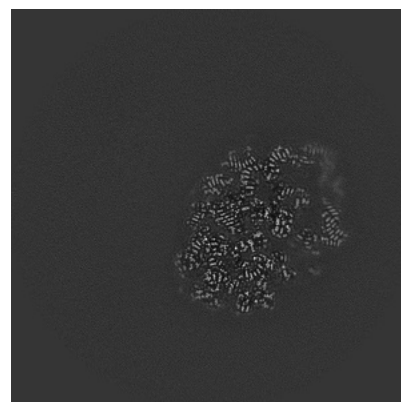

Z Index: 240

The images above show central slices of the map in three orthogonal directions.

6.3 Largest variance slices [i](#)

6.3.1 Primary map

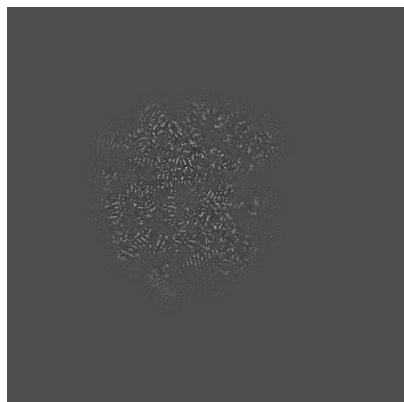

X Index: 277



Y Index: 229



Z Index: 290

6.3.2 Raw map

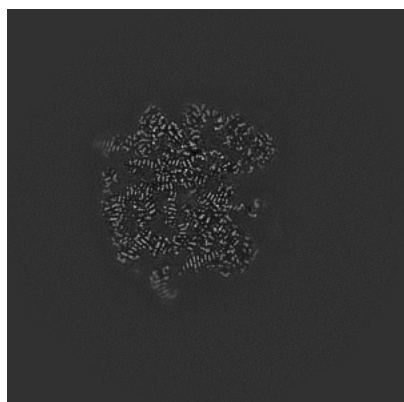

X Index: 277

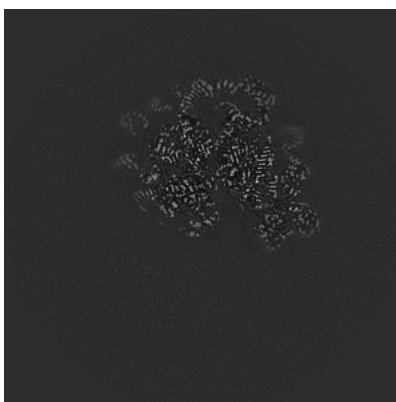

Y Index: 229

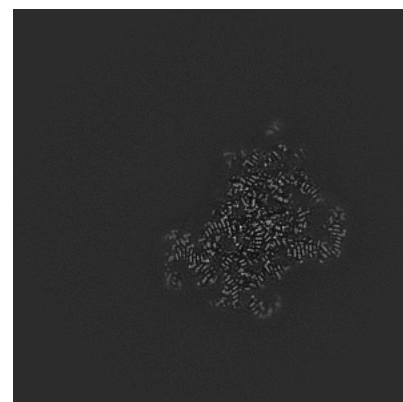

Z Index: 290

The images above show the largest variance slices of the map in three orthogonal directions.

6.4 Orthogonal standard-deviation projections (False-color) [i](#)

6.4.1 Primary map

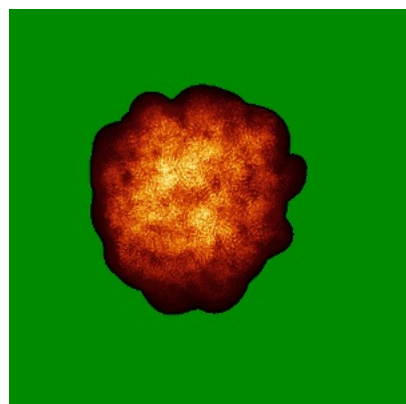

X

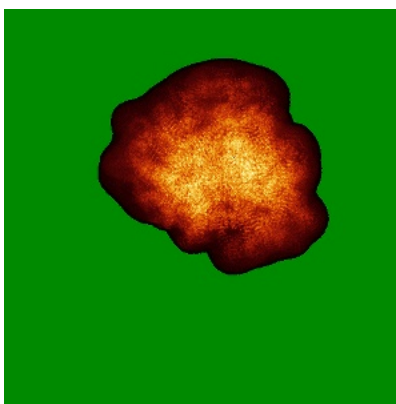

Y

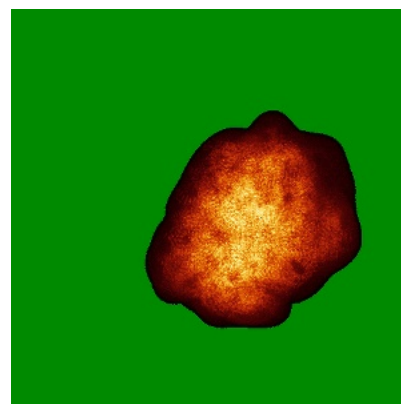

Z

6.4.2 Raw map

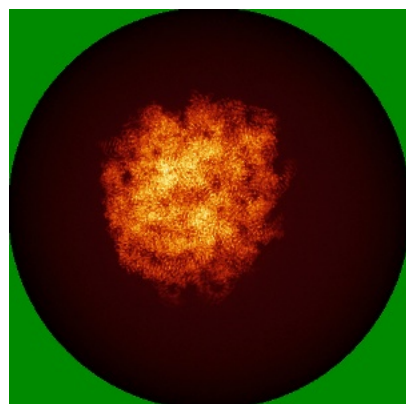

X

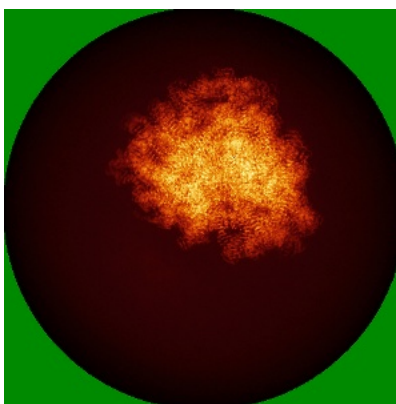

Y

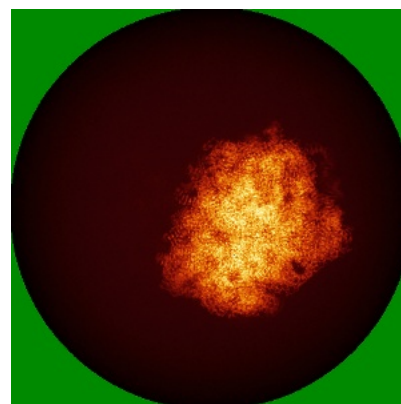

Z

The images above show the map standard deviation projections with false color in three orthogonal directions. Minimum values are shown in green, max in blue, and dark to light orange shades represent small to large values respectively.

6.5 Orthogonal surface views [i](#)

6.5.1 Primary map

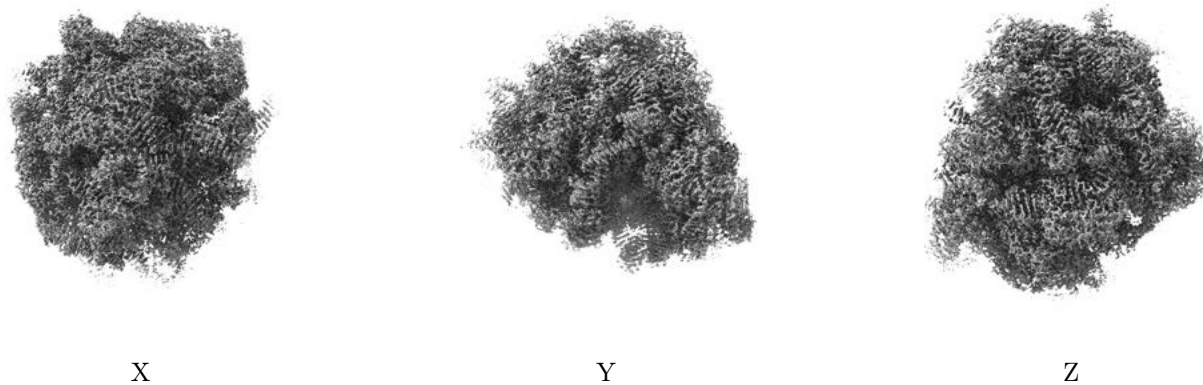

The images above show the 3D surface view of the map at the recommended contour level 0.0309. These images, in conjunction with the slice images, may facilitate assessment of whether an appropriate contour level has been provided.

6.5.2 Raw map

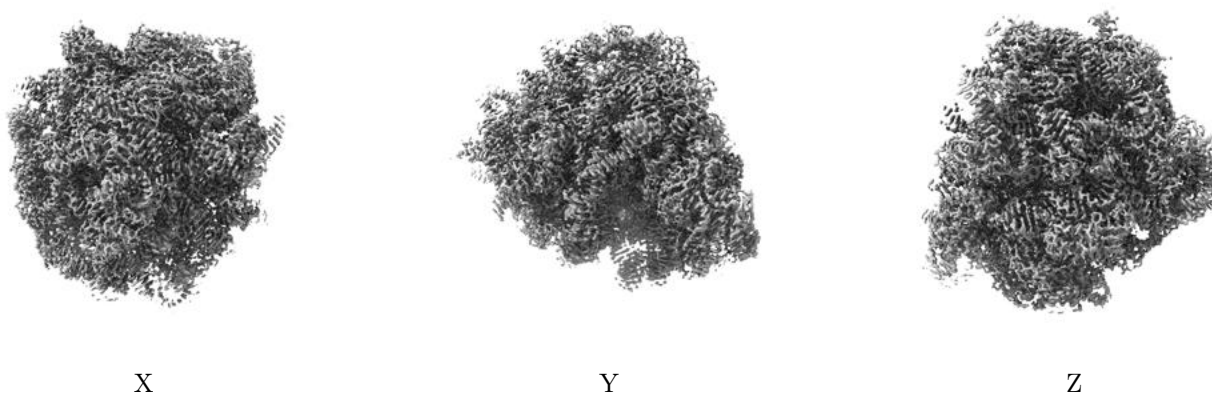

These images show the 3D surface of the raw map. The raw map's contour level was selected so that its surface encloses the same volume as the primary map does at its recommended contour level.

6.6 Mask visualisation [i](#)

This section was not generated. No masks/segmentation were deposited.

7 Map analysis [i](#)

This section contains the results of statistical analysis of the map.

7.1 Map-value distribution [i](#)

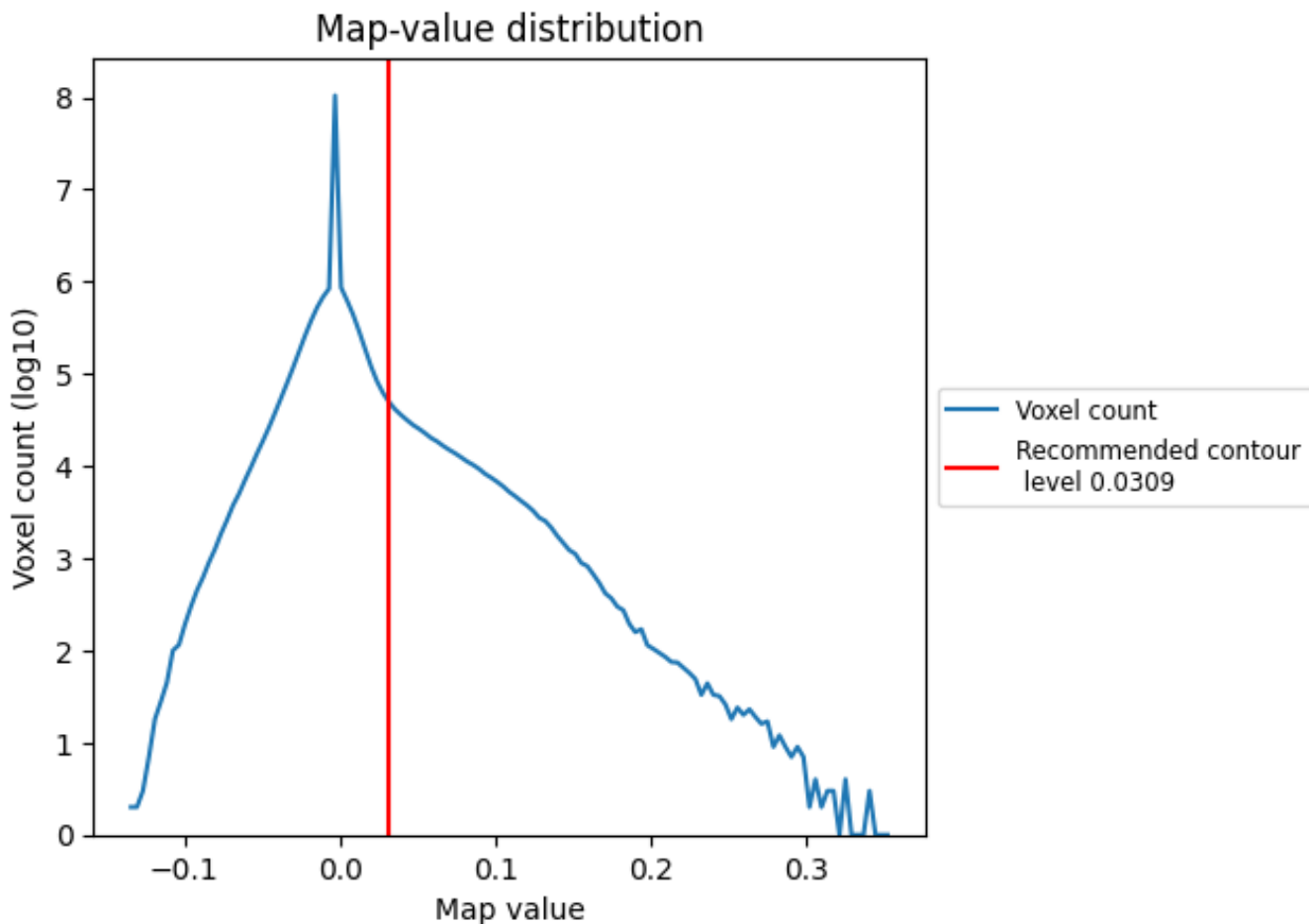

The map-value distribution is plotted in 128 intervals along the x-axis. The y-axis is logarithmic. A spike in this graph at zero usually indicates that the volume has been masked.

7.2 Volume estimate [i](#)

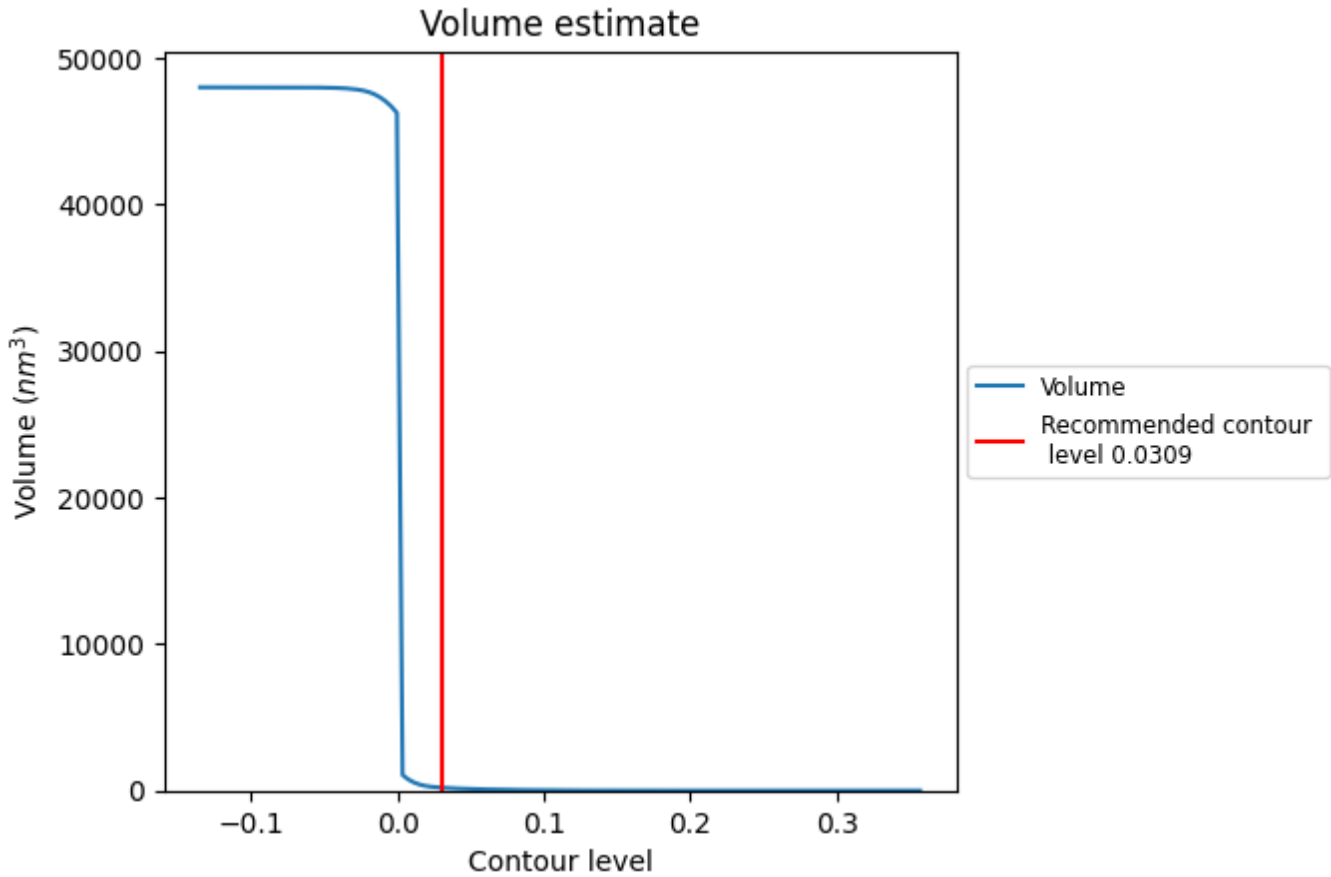

The volume at the recommended contour level is 192 nm³; this corresponds to an approximate mass of 173 kDa.

The volume estimate graph shows how the enclosed volume varies with the contour level. The recommended contour level is shown as a vertical line and the intersection between the line and the curve gives the volume of the enclosed surface at the given level.

7.3 Rotationally averaged power spectrum i

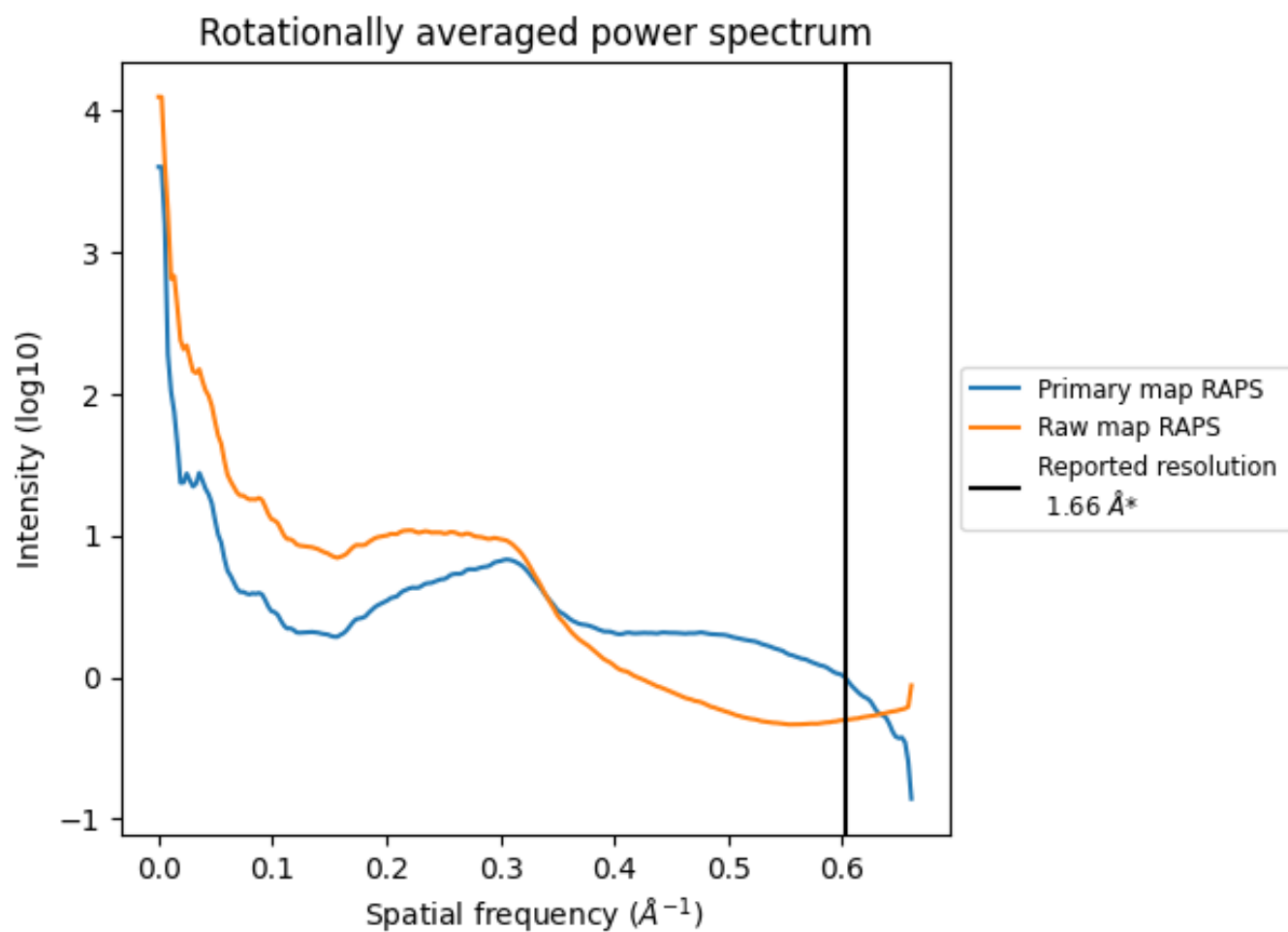

*Reported resolution corresponds to spatial frequency of 0.602 Å⁻¹

8 Fourier-Shell correlation [i](#)

Fourier-Shell Correlation (FSC) is the most commonly used method to estimate the resolution of single-particle and subtomogram-averaged maps. The shape of the curve depends on the imposed symmetry, mask and whether or not the two 3D reconstructions used were processed from a common reference. The reported resolution is shown as a black line. A curve is displayed for the half-bit criterion in addition to lines showing the 0.143 gold standard cut-off and 0.5 cut-off.

8.1 FSC [i](#)

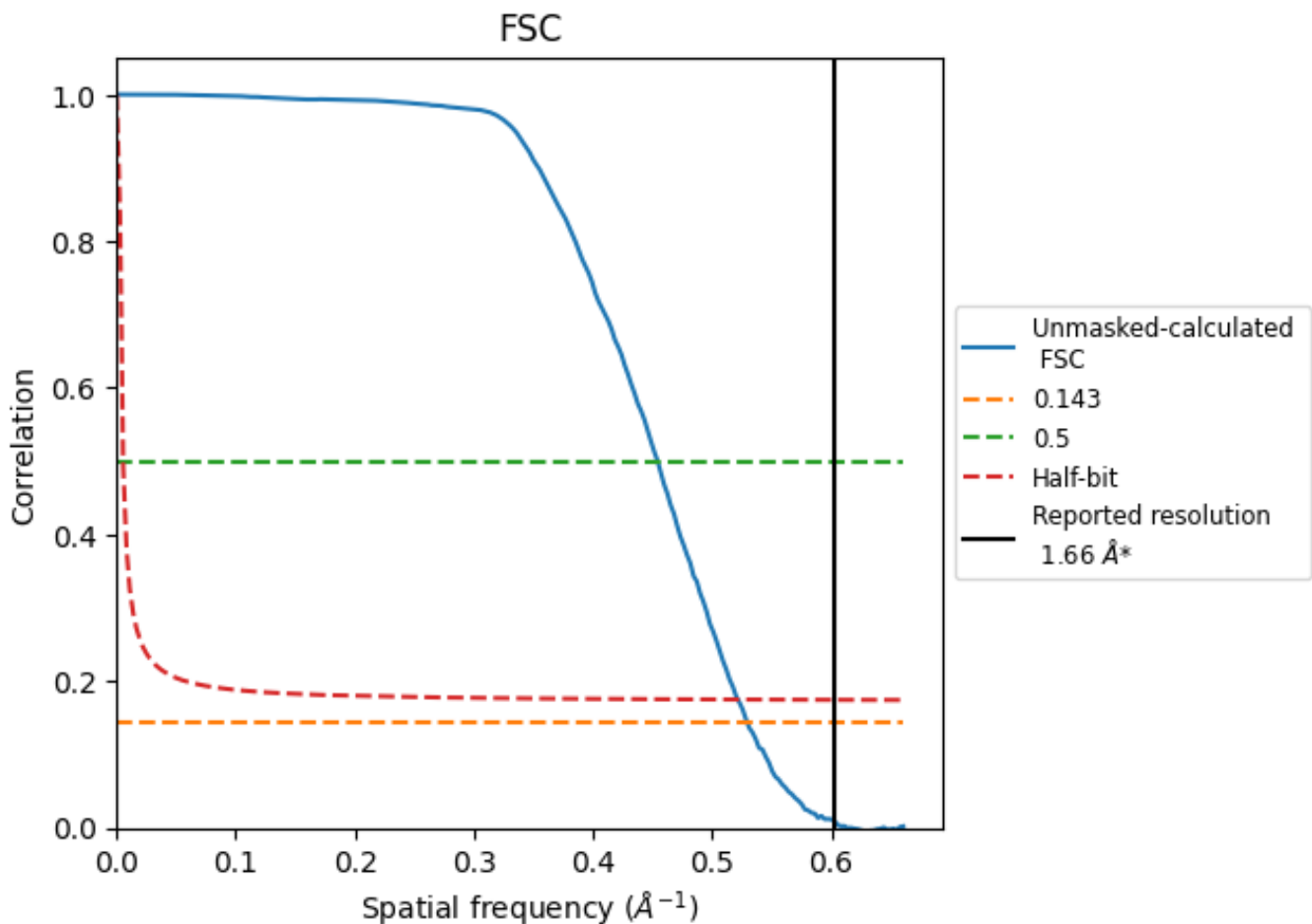

*Reported resolution corresponds to spatial frequency of 0.602\AA^{-1}

8.2 Resolution estimates [i](#)

Resolution estimate (Å)	Estimation criterion (FSC cut-off)		
	0.143	0.5	Half-bit
Reported by author	1.66	-	-
Author-provided FSC curve	-	-	-
Unmasked-calculated*	1.89	2.20	1.92

*Resolution estimate based on FSC curve calculated by comparison of deposited half-maps. The value from deposited half-maps intersecting FSC 0.143 CUT-OFF 1.89 differs from the reported value 1.66 by more than 10 %

9 Map-model fit [i](#)

This section contains information regarding the fit between EMDB map EMD-16652 and PDB model 8CGV. Per-residue inclusion information can be found in section [3](#) on page [12](#).

9.1 Map-model overlay [i](#)

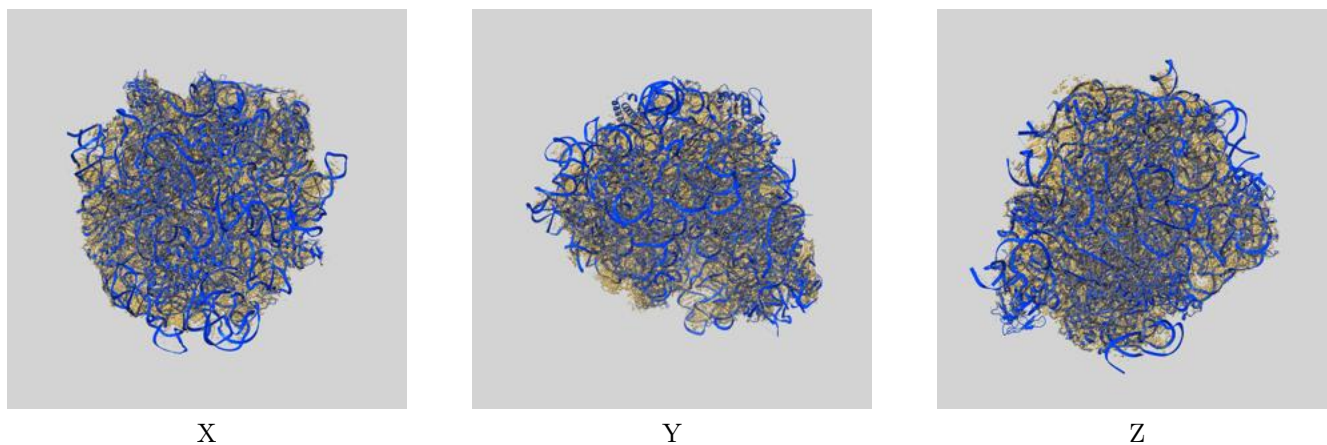

The images above show the 3D surface view of the map at the recommended contour level 0.0309 at 50% transparency in yellow overlaid with a ribbon representation of the model coloured in blue. These images allow for the visual assessment of the quality of fit between the atomic model and the map.

9.2 Q-score mapped to coordinate model [i](#)

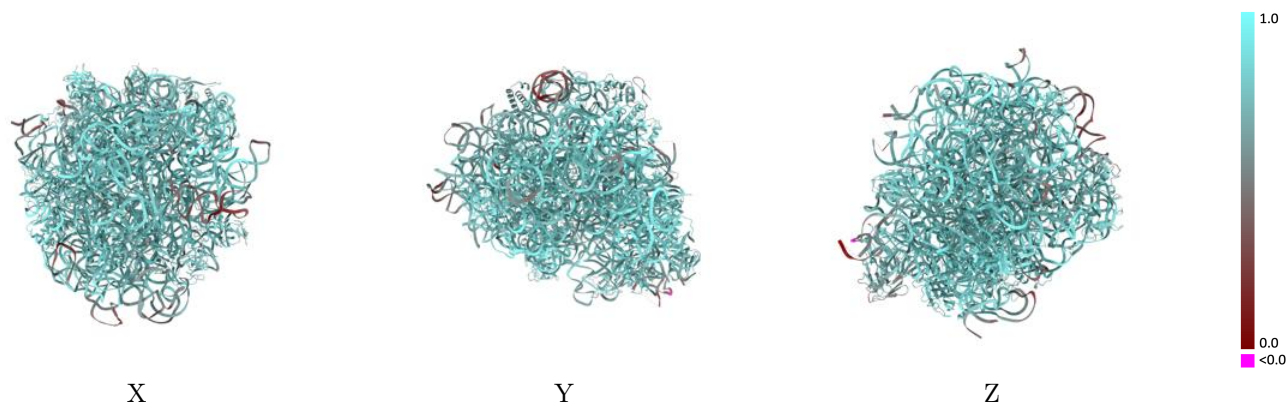

The images above show the model with each residue coloured according to its Q-score. This shows their resolvability in the map with higher Q-score values reflecting better resolvability. Please note: Q-score is calculating the resolvability of atoms, and thus high values are only expected at resolutions at which atoms can be resolved. Low Q-score values may therefore be expected for many entries.

9.3 Atom inclusion mapped to coordinate model [i](#)

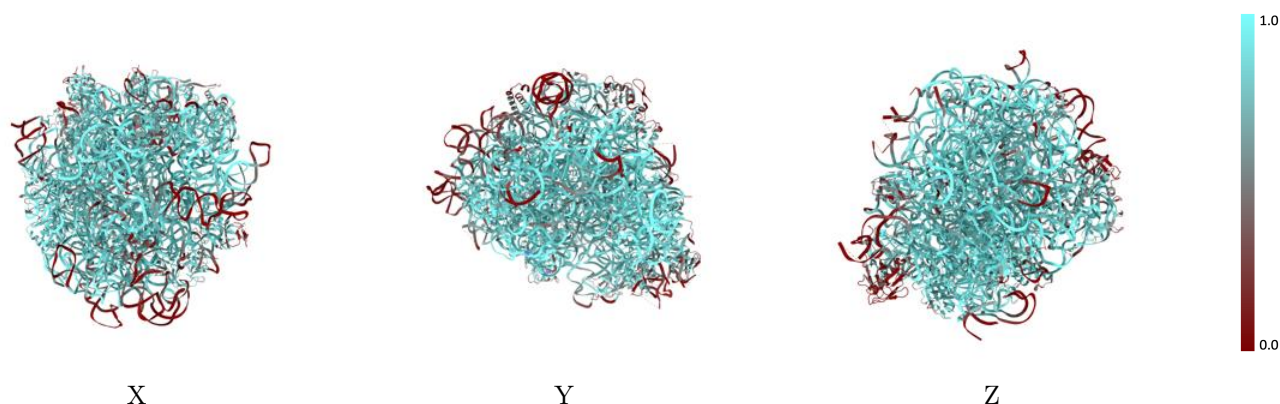

The images above show the model with each residue coloured according to its atom inclusion. This shows to what extent they are inside the map at the recommended contour level (0.0309).



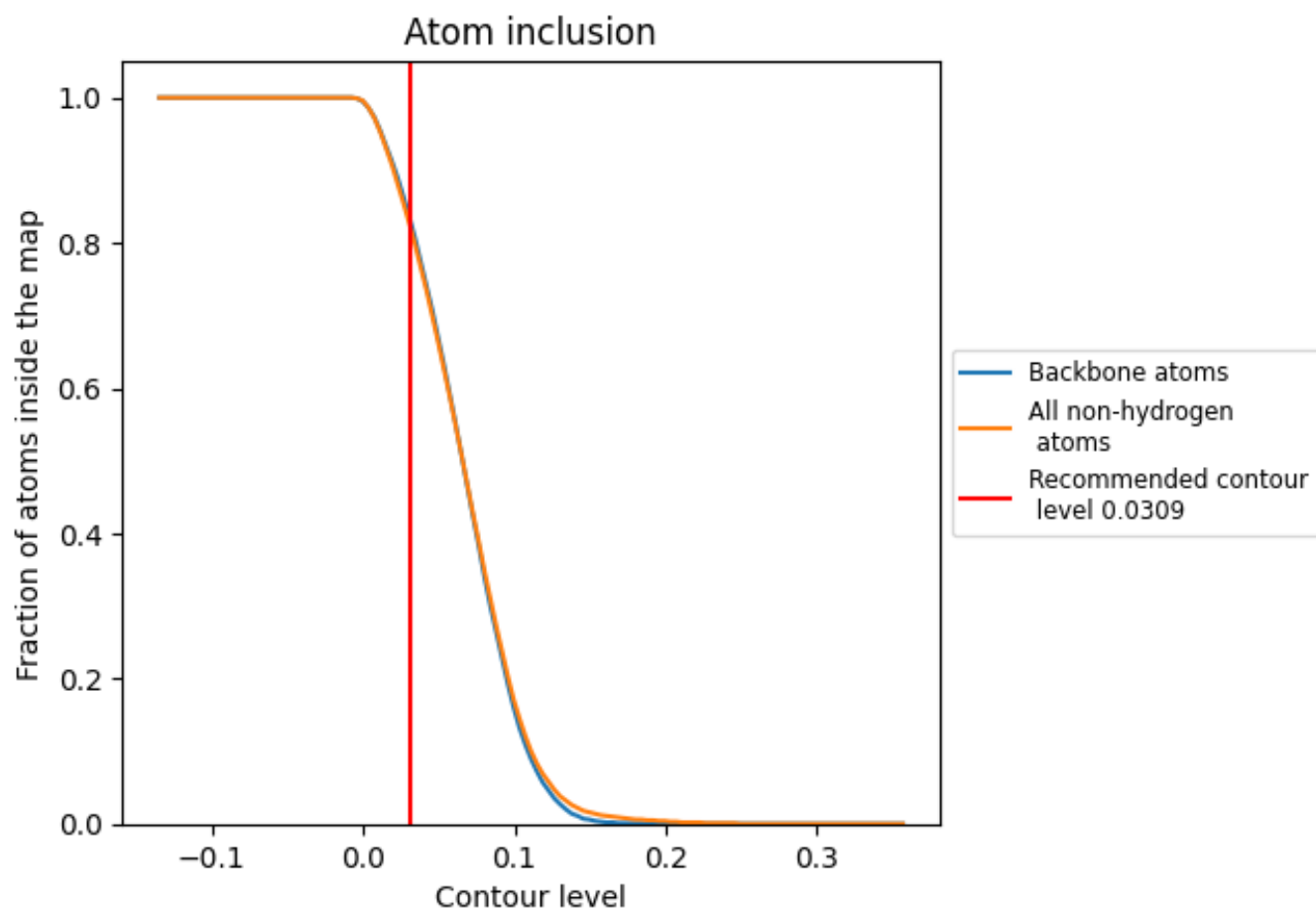

























































9.4 Atom inclusion [i](#)



At the recommended contour level, 83% of all backbone atoms, 82% of all non-hydrogen atoms, are inside the map.

9.5 Map-model fit summary

The table lists the average atom inclusion at the recommended contour level (0.0309) and Q-score for the entire model and for each chain.

Chain	Atom inclusion	Q-score
All	 0.8240	 0.8070
0	 0.7260	 0.7850
1	 0.9470	 0.8550
2	 0.9410	 0.8620
3	 0.8290	 0.8120
a	 0.8480	 0.8090
b	 0.7480	 0.7720
c	 0.8920	 0.8420
d	 0.8780	 0.8380
e	 0.6530	 0.7740
g	 0.2470	 0.6270
h	 0.4380	 0.7210
i	 0.8780	 0.8340
j	 0.8120	 0.8180
k	 0.7940	 0.8090
l	 0.8350	 0.8260
m	 0.9490	 0.8640
n	 0.5480	 0.7220
o	 0.7950	 0.8060
p	 0.9360	 0.8600
q	 0.7450	 0.8000
r	 0.8460	 0.8260
s	 0.7070	 0.7750
t	 0.6580	 0.7620
u	 0.5800	 0.7430
v	 0.8660	 0.8230
w	 0.7890	 0.8150
x	 0.4810	 0.7040
y	 0.8290	 0.8210
z	 0.8180	 0.8130

