



Full wwPDB X-ray Structure Validation Report ⓘ

Jun 19, 2020 – 08:18 pm BST

PDB ID : 5EIG
Title : Engineered human cystathionine gamma lyase (E59T, E339V) to deplet cysteine
Authors : Yan, W.; Zhang, J.
Deposited on : 2015-10-29
Resolution : 2.70 Å(reported)

This is a Full wwPDB X-ray Structure Validation Report for a publicly released PDB entry.

We welcome your comments at validation@mail.wwpdb.org

A user guide is available at

<https://www.wwpdb.org/validation/2017/XrayValidationReportHelp>

with specific help available everywhere you see the ⓘ symbol.

The following versions of software and data (see [references ⓘ](#)) were used in the production of this report:

MolProbity : 4.02b-467
Mogul : 1.8.5 (274361), CSD as541be (2020)
Xtriage (Phenix) : 1.13
EDS : 2.11
Percentile statistics : 20191225.v01 (using entries in the PDB archive December 25th 2019)
Refmac : 5.8.0158
CCP4 : 7.0.044 (Gargrove)
Ideal geometry (proteins) : Engh & Huber (2001)
Ideal geometry (DNA, RNA) : Parkinson et al. (1996)
Validation Pipeline (wwPDB-VP) : 2.11

1 Overall quality at a glance

The following experimental techniques were used to determine the structure:
X-RAY DIFFRACTION

The reported resolution of this entry is 2.70 Å.

Percentile scores (ranging between 0-100) for global validation metrics of the entry are shown in the following graphic. The table shows the number of entries on which the scores are based.

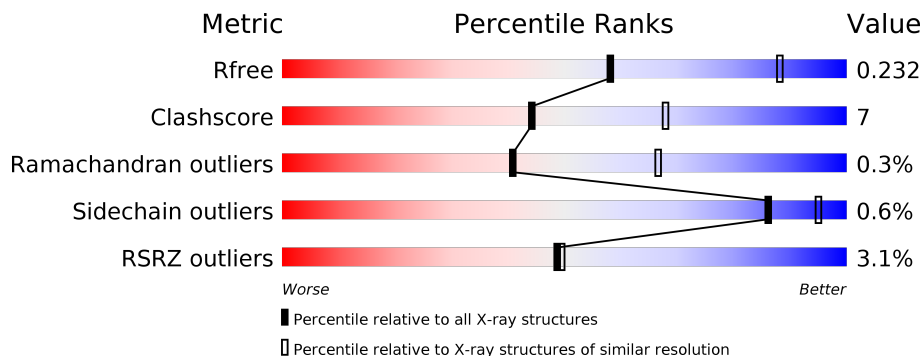

Metric	Whole archive (#Entries)	Similar resolution (#Entries, resolution range(Å))
R_{free}	130704	2808 (2.70-2.70)
Clashscore	141614	3122 (2.70-2.70)
Ramachandran outliers	138981	3069 (2.70-2.70)
Sidechain outliers	138945	3069 (2.70-2.70)
RSRZ outliers	127900	2737 (2.70-2.70)

The table below summarises the geometric issues observed across the polymeric chains and their fit to the electron density. The red, orange, yellow and green segments on the lower bar indicate the fraction of residues that contain outliers for ≥ 3 , 2, 1 and 0 types of geometric quality criteria respectively. A grey segment represents the fraction of residues that are not modelled. The numeric value for each fraction is indicated below the corresponding segment, with a dot representing fractions $\leq 5\%$. The upper red bar (where present) indicates the fraction of residues that have poor fit to the electron density. The numeric value is given above the bar.

Mol	Chain	Length	Quality of chain
1	A	405	 2% 76% 19% 5%
1	C	405	 4% 82% 13% .
1	D	405	 3% 82% 13% .
1	E	405	 81% 14% 5%
1	F	405	 3% 81% 13% 6%
1	G	405	 83% 13% .

Continued on next page...

Continued from previous page...

Mol	Chain	Length	Quality of chain
2	B	405	 6% 78% 17% 5%
2	H	405	 4% 82% 14% 5%

2 Entry composition [i](#)

There are 5 unique types of molecules in this entry. The entry contains 24750 atoms, of which 0 are hydrogens and 0 are deuteriums.

In the tables below, the ZeroOcc column contains the number of atoms modelled with zero occupancy, the AltConf column contains the number of residues with at least one atom in alternate conformation and the Trace column contains the number of residues modelled with at most 2 atoms.

- Molecule 1 is a protein called Cystathionine gamma-lyase.

Mol	Chain	Residues	Atoms						ZeroOcc	AltConf	Trace
			Total	C	N	O	P	S			
1	A	384	2995	1909	510	555	1	20	0	0	0
1	C	388	3017	1922	514	560	1	20	0	0	0
1	D	387	3013	1920	513	559	1	20	0	0	0
1	E	385	3002	1914	511	556	1	20	0	0	0
1	F	382	2985	1901	510	553	1	20	0	0	0
1	G	388	3020	1924	515	560	1	20	0	0	0

There are 12 discrepancies between the modelled and reference sequences:

Chain	Residue	Modelled	Actual	Comment	Reference
A	59	THR	GLU	engineered mutation	UNP P32929
A	339	VAL	GLU	engineered mutation	UNP P32929
C	59	THR	GLU	engineered mutation	UNP P32929
C	339	VAL	GLU	engineered mutation	UNP P32929
D	59	THR	GLU	engineered mutation	UNP P32929
D	339	VAL	GLU	engineered mutation	UNP P32929
E	59	THR	GLU	engineered mutation	UNP P32929
E	339	VAL	GLU	engineered mutation	UNP P32929
F	59	THR	GLU	engineered mutation	UNP P32929
F	339	VAL	GLU	engineered mutation	UNP P32929
G	59	THR	GLU	engineered mutation	UNP P32929
G	339	VAL	GLU	engineered mutation	UNP P32929

- Molecule 2 is a protein called Cystathionine gamma-lyase.

Mol	Chain	Residues	Atoms						ZeroOcc	AltConf	Trace
			Total	C	N	O	P	S			
2	B	386	3001	1912	513	556	1	19	0	0	0
2	H	387	3005	1916	512	557	1	19	0	0	0

There are 4 discrepancies between the modelled and reference sequences:

Chain	Residue	Modelled	Actual	Comment	Reference
B	59	THR	GLU	engineered mutation	UNP P32929
B	339	VAL	GLU	engineered mutation	UNP P32929
H	59	THR	GLU	engineered mutation	UNP P32929
H	339	VAL	GLU	engineered mutation	UNP P32929

- Molecule 3 is SULFATE ION (three-letter code: SO₄) (formula: O₄S).

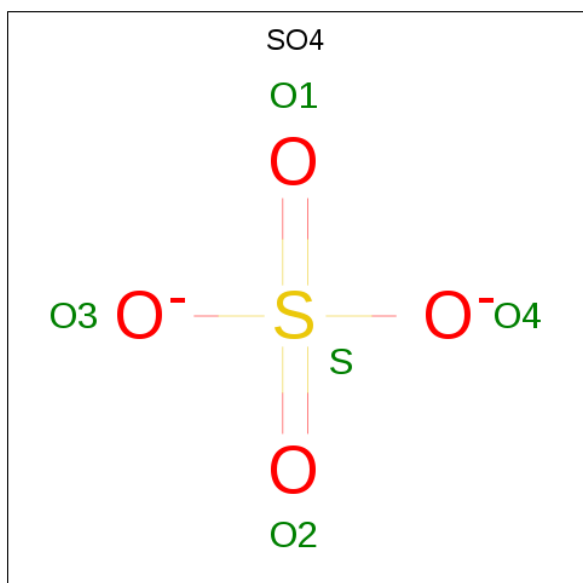

Mol	Chain	Residues	Atoms			ZeroOcc	AltConf
			Total	O	S		
3	B	1	5	4	1	0	0
3	B	1	5	4	1	0	0
3	D	1	5	4	1	0	0
3	F	1	5	4	1	0	0
3	H	1	5	4	1	0	0

- Molecule 4 is CYSTEINE (three-letter code: CYS) (formula: C₃H₇NO₂S).

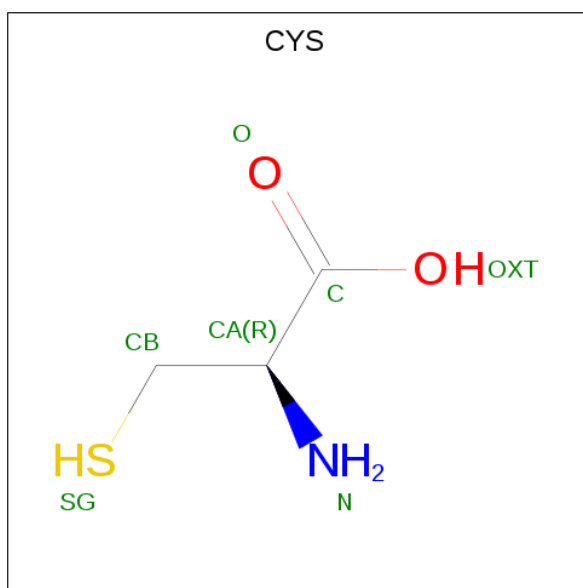

Mol	Chain	Residues	Atoms					ZeroOcc	AltConf
			Total	C	N	O	S		
4	C	1	7	3	1	2	1	0	0
4	E	1	7	3	1	2	1	0	0
4	G	1	7	3	1	2	1	0	0

- Molecule 5 is water.

Mol	Chain	Residues	Atoms		ZeroOcc	AltConf
			Total	O		
5	A	72	72	72	0	0
5	B	57	57	57	0	0
5	C	62	62	62	0	0
5	D	67	67	67	0	0
5	E	94	94	94	0	0
5	F	85	85	85	0	0
5	G	128	128	128	0	0
5	H	101	101	101	0	0

3 Residue-property plots [i](#)

These plots are drawn for all protein, RNA and DNA chains in the entry. The first graphic for a chain summarises the proportions of the various outlier classes displayed in the second graphic. The second graphic shows the sequence view annotated by issues in geometry and electron density. Residues are color-coded according to the number of geometric quality criteria for which they contain at least one outlier: green = 0, yellow = 1, orange = 2 and red = 3 or more. A red dot above a residue indicates a poor fit to the electron density ($RSRZ > 2$). Stretches of 2 or more consecutive residues without any outlier are shown as a green connector. Residues present in the sample, but not in the model, are shown in grey.

- Molecule 1: Cystathionine gamma-lyase

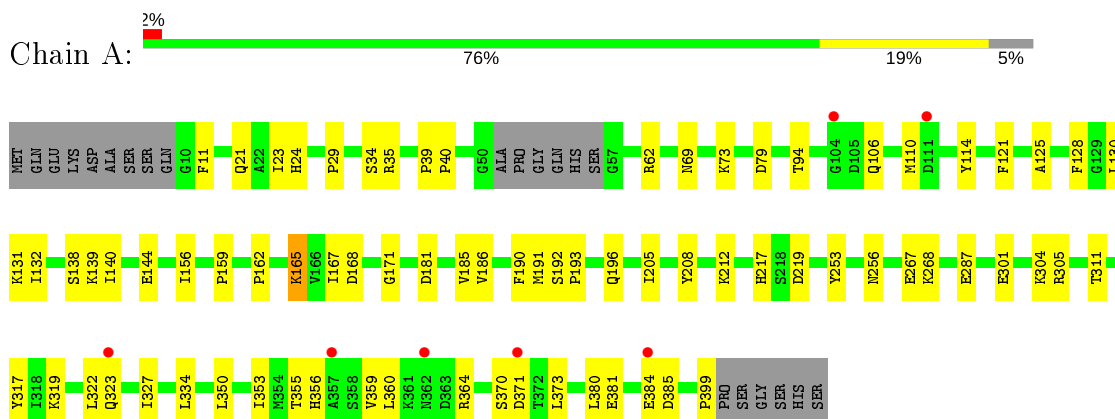

- Molecule 1: Cystathionine gamma-lyase

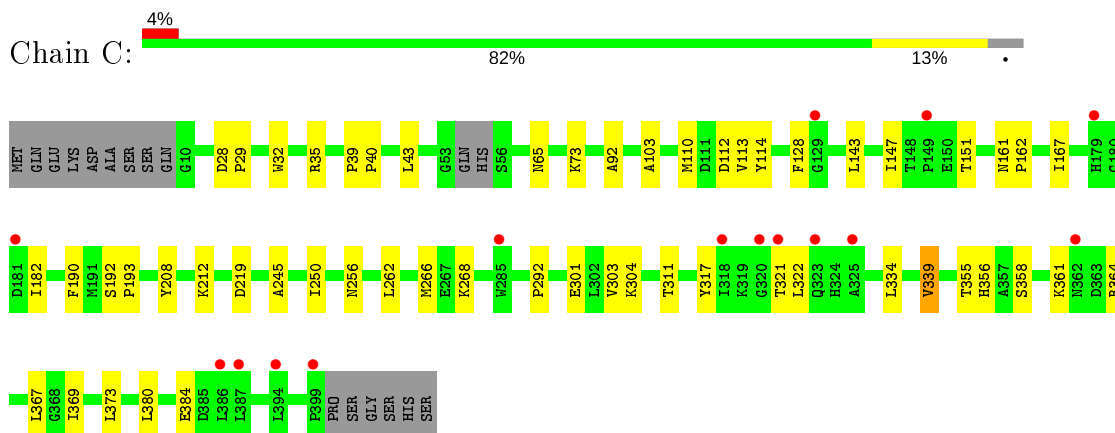

- Molecule 1: Cystathionine gamma-lyase

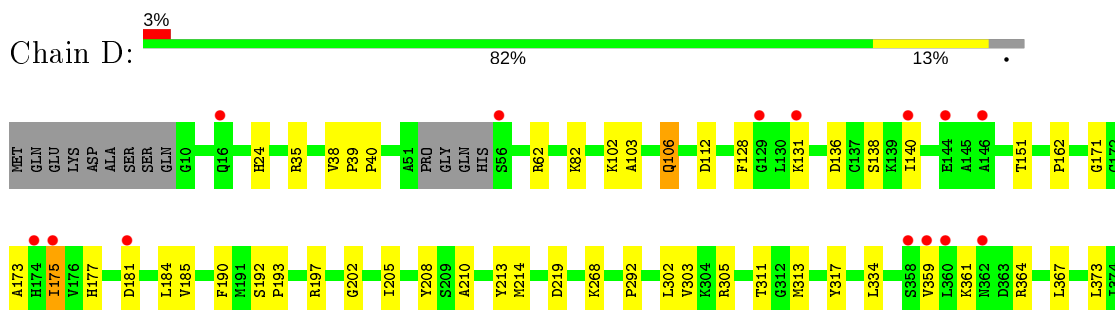

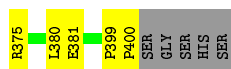

• Molecule 1: Cystathionine gamma-lyase

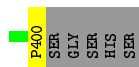
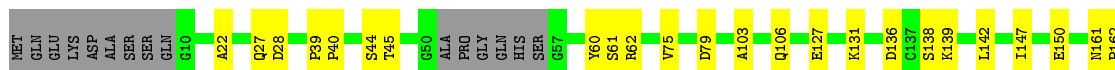
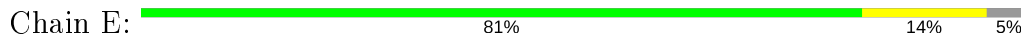

• Molecule 1: Cystathionine gamma-lyase

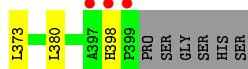
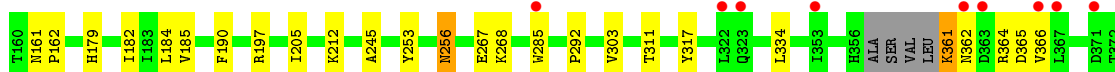
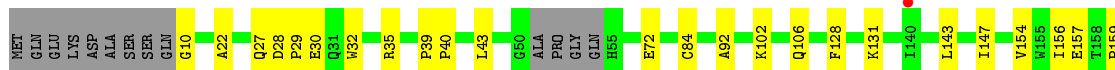
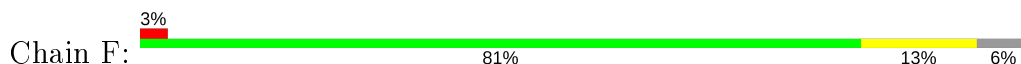

• Molecule 1: Cystathionine gamma-lyase

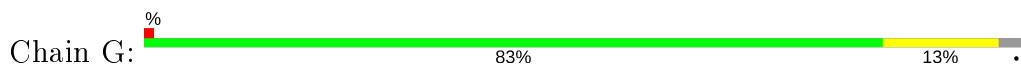

• Molecule 2: Cystathionine gamma-lyase

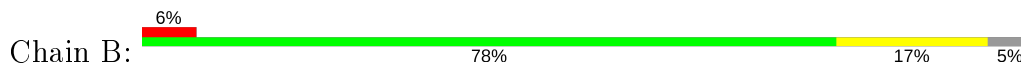

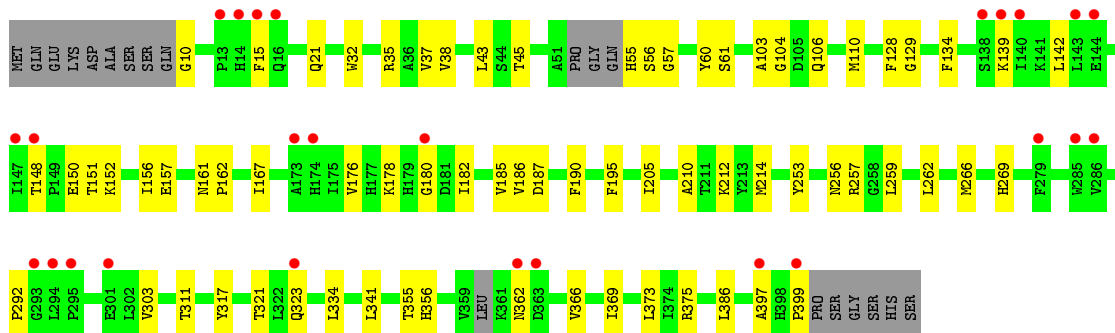

- Molecule 2: Cystathionine gamma-lyase

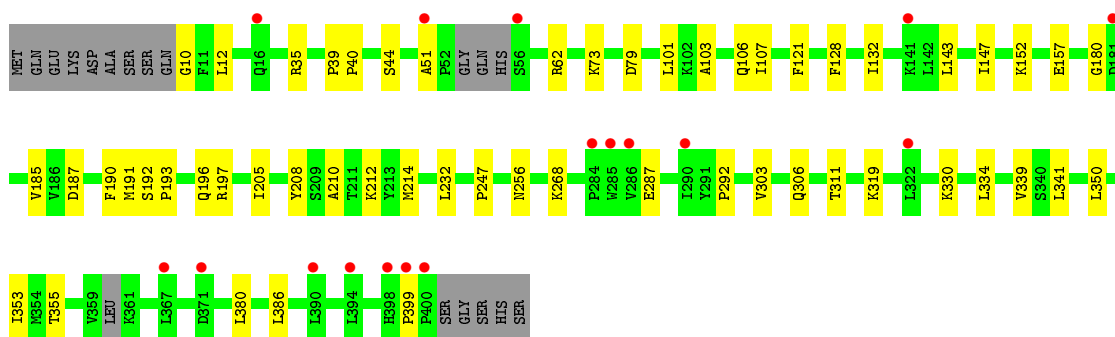
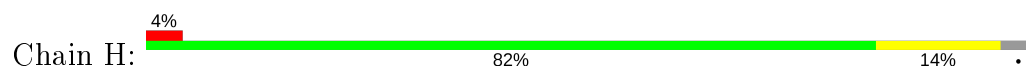

4 Data and refinement statistics

Property	Value	Source
Space group	P 2 21 21	Depositor
Cell constants a, b, c, α , β , γ	113.38Å 163.46Å 181.62Å 90.00° 90.00° 90.00°	Depositor
Resolution (Å)	40.00 – 2.70 49.11 – 2.70	Depositor EDS
% Data completeness (in resolution range)	98.8 (40.00-2.70) 98.9 (49.11-2.70)	Depositor EDS
R_{merge}	(Not available)	Depositor
R_{sym}	0.14	Depositor
$\langle I/\sigma(I) \rangle$ ¹	2.70 (at 2.69Å)	Xtrriage
Refinement program	PHENIX 1.9_1692	Depositor
R, R_{free}	0.191 , 0.233 0.193 , 0.232	Depositor DCC
R_{free} test set	4640 reflections (5.02%)	wwPDB-VP
Wilson B-factor (Å ²)	31.1	Xtrriage
Anisotropy	0.506	Xtrriage
Bulk solvent k_{sol} (e/Å ³), B_{sol} (Å ²)	0.31 , 37.0	EDS
L-test for twinning ²	$\langle L \rangle = 0.48$, $\langle L^2 \rangle = 0.31$	Xtrriage
Estimated twinning fraction	No twinning to report.	Xtrriage
F_o, F_c correlation	0.92	EDS
Total number of atoms	24750	wwPDB-VP
Average B, all atoms (Å ²)	34.0	wwPDB-VP

Xtrriage's analysis on translational NCS is as follows: *The analyses of the Patterson function reveals a significant off-origin peak that is 25.88 % of the origin peak, indicating pseudo-translational symmetry. The chance of finding a peak of this or larger height randomly in a structure without pseudo-translational symmetry is equal to 2.9187e-03. The detected translational NCS is most likely also responsible for the elevated intensity ratio.*

¹Intensities estimated from amplitudes.

²Theoretical values of $\langle |L| \rangle$, $\langle L^2 \rangle$ for acentric reflections are 0.5, 0.333 respectively for untwinned datasets, and 0.375, 0.2 for perfectly twinned datasets.

5 Model quality i

5.1 Standard geometry i

Bond lengths and bond angles in the following residue types are not validated in this section: LLP, 5OW, SO4

The Z score for a bond length (or angle) is the number of standard deviations the observed value is removed from the expected value. A bond length (or angle) with $|Z| > 5$ is considered an outlier worth inspection. RMSZ is the root-mean-square of all Z scores of the bond lengths (or angles).

Mol	Chain	Bond lengths		Bond angles	
		RMSZ	# Z >5	RMSZ	# Z >5
1	A	0.28	0/3029	0.49	0/4109
1	C	0.25	0/3052	0.45	1/4141 (0.0%)
1	D	0.24	0/3048	0.46	0/4136
1	E	0.23	0/3037	0.45	0/4121
1	F	0.24	0/3019	0.45	0/4093
1	G	0.25	0/3055	0.46	0/4145
2	B	0.24	0/3042	0.46	0/4125
2	H	0.25	0/3047	0.46	0/4134
All	All	0.25	0/24329	0.46	1/33004 (0.0%)

Chiral center outliers are detected by calculating the chiral volume of a chiral center and verifying if the center is modelled as a planar moiety or with the opposite hand. A planarity outlier is detected by checking planarity of atoms in a peptide group, atoms in a mainchain group or atoms of a sidechain that are expected to be planar.

Mol	Chain	#Chirality outliers	#Planarity outliers
1	G	0	1

There are no bond length outliers.

All (1) bond angle outliers are listed below:

Mol	Chain	Res	Type	Atoms	Z	Observed(°)	Ideal(°)
1	C	113	VAL	CB-CA-C	-5.23	101.47	111.40

There are no chirality outliers.

All (1) planarity outliers are listed below:

Mol	Chain	Res	Type	Group
1	G	212	5OW	Mainchain

5.2 Too-close contacts [i](#)

In the following table, the Non-H and H(model) columns list the number of non-hydrogen atoms and hydrogen atoms in the chain respectively. The H(added) column lists the number of hydrogen atoms added and optimized by MolProbity. The Clashes column lists the number of clashes within the asymmetric unit, whereas Symm-Clashes lists symmetry related clashes.

Mol	Chain	Non-H	H(model)	H(added)	Clashes	Symm-Clashes
1	A	2995	0	2965	60	0
1	C	3017	0	2985	37	0
1	D	3013	0	2982	35	0
1	E	3002	0	2972	41	0
1	F	2985	0	2946	37	0
1	G	3020	0	2988	44	0
2	B	3001	0	2987	45	0
2	H	3005	0	2994	45	0
3	B	10	0	0	2	0
3	D	5	0	0	0	0
3	F	5	0	0	0	0
3	H	5	0	0	0	0
4	C	7	0	4	3	0
4	E	7	0	4	1	0
4	G	7	0	4	3	0
5	A	72	0	0	14	0
5	B	57	0	0	7	0
5	C	62	0	0	6	0
5	D	67	0	0	7	0
5	E	94	0	0	13	0
5	F	85	0	0	12	0
5	G	128	0	0	10	0
5	H	101	0	0	11	0
All	All	24750	0	23831	318	0

The all-atom clashscore is defined as the number of clashes found per 1000 atoms (including hydrogen atoms). The all-atom clashscore for this structure is 7.

All (318) close contacts within the same asymmetric unit are listed below, sorted by their clash magnitude.

Atom-1	Atom-2	Interatomic distance (Å)	Clash overlap (Å)
1:C:114:TYR:HH	4:C:501:CYS:N	1.57	1.01
1:A:364:ARG:NH1	5:A:505:HOH:O	2.01	0.94
1:F:10:GLY:N	5:F:605:HOH:O	2.02	0.91
1:C:384:GLU:OE2	5:C:601:HOH:O	1.88	0.90

Continued on next page...

Continued from previous page...

Atom-1	Atom-2	Interatomic distance (Å)	Clash overlap (Å)
1:A:359:VAL:O	1:A:364:ARG:NE	2.06	0.88
1:E:44:SER:O	5:E:601:HOH:O	1.90	0.87
1:E:267:GLU:OE2	5:E:602:HOH:O	1.93	0.86
1:A:267:GLU:OE1	5:A:502:HOH:O	1.93	0.86
1:F:157:GLU:OE2	5:F:602:HOH:O	1.94	0.85
1:E:22:ALA:O	5:E:603:HOH:O	1.95	0.85
2:B:257:ARG:NH1	5:B:604:HOH:O	2.11	0.84
1:C:358:SER:O	5:C:602:HOH:O	1.96	0.83
1:F:362:ASN:O	5:F:603:HOH:O	1.95	0.83
2:B:10:GLY:N	5:B:603:HOH:O	2.10	0.82
2:H:44:SER:O	5:H:601:HOH:O	1.96	0.82
1:A:159:PRO:O	5:A:504:HOH:O	1.99	0.81
1:F:106:GLN:HB2	1:F:131:LYS:HE3	1.65	0.79
2:B:21:GLN:OE1	5:B:601:HOH:O	1.99	0.78
1:F:22:ALA:O	5:F:604:HOH:O	2.01	0.78
1:C:301:GLU:O	5:C:604:HOH:O	2.03	0.77
2:H:180:GLY:O	5:H:602:HOH:O	2.01	0.77
2:H:35:ARG:NE	5:H:605:HOH:O	2.11	0.76
2:H:287:GLU:HG2	2:H:319:LYS:HG2	1.66	0.76
2:H:12:LEU:O	5:H:603:HOH:O	2.04	0.76
2:B:139:LYS:HB3	2:B:142:LEU:HD23	1.69	0.75
1:G:338:ALA:O	5:G:601:HOH:O	2.03	0.74
1:D:102:LYS:NZ	5:D:605:HOH:O	2.21	0.74
1:G:287:GLU:HG2	1:G:319:LYS:HG2	1.69	0.73
4:G:501:CYS:N	5:G:608:HOH:O	2.19	0.73
1:F:267:GLU:OE2	5:F:606:HOH:O	2.07	0.72
2:H:247:PRO:O	5:H:604:HOH:O	2.06	0.72
1:E:264:VAL:O	5:E:604:HOH:O	2.09	0.71
1:G:12:LEU:O	5:G:602:HOH:O	2.10	0.70
1:A:287:GLU:HG2	1:A:319:LYS:HG2	1.73	0.70
2:B:106:GLN:NE2	2:B:151:THR:OG1	2.23	0.70
1:F:159:PRO:O	5:F:607:HOH:O	2.09	0.70
2:B:43:LEU:O	5:B:602:HOH:O	2.09	0.70
1:A:106:GLN:HG3	1:A:131:LYS:HB3	1.73	0.69
1:C:212:5OW:S11	4:C:501:CYS:N	2.66	0.68
1:G:16:GLN:O	5:G:604:HOH:O	2.11	0.68
1:G:391:ASP:OD1	5:G:603:HOH:O	2.11	0.68
2:B:134:PHE:O	5:B:605:HOH:O	2.13	0.67
1:A:62:ARG:NH2	3:B:502:SO4:O1	2.29	0.66
1:E:127:GLU:OE1	5:E:606:HOH:O	2.12	0.66
1:G:65:ASN:OD1	5:G:605:HOH:O	2.12	0.66

Continued on next page...

Continued from previous page...

Atom-1	Atom-2	Interatomic distance (Å)	Clash overlap (Å)
1:D:334:LEU:O	5:D:603:HOH:O	2.14	0.66
1:G:157:GLU:OE2	5:G:607:HOH:O	2.13	0.66
1:E:106:GLN:NE2	1:E:150:GLU:HB2	2.10	0.66
1:F:32:TRP:O	1:F:35:ARG:NH1	2.28	0.65
1:C:364:ARG:HB3	1:C:369:ILE:HB	1.78	0.65
2:H:212:LLP:HD3	2:H:341:LEU:HG	1.76	0.65
1:A:106:GLN:OE1	1:A:106:GLN:N	2.30	0.65
1:A:219:ASP:O	5:A:509:HOH:O	2.15	0.64
1:D:35:ARG:NE	5:D:609:HOH:O	2.30	0.64
1:E:40:PRO:O	5:E:607:HOH:O	2.15	0.64
1:E:62:ARG:NH2	1:F:212:5OW:OP2	2.30	0.64
1:G:62:ARG:NH1	2:H:212:LLP:OP3	2.30	0.63
1:A:94:THR:OG1	5:A:501:HOH:O	1.87	0.63
1:A:323:GLN:HE21	1:A:327:ILE:HG13	1.64	0.62
2:B:212:LLP:HD3	2:B:341:LEU:HG	1.81	0.62
1:A:139:LYS:NZ	5:A:515:HOH:O	2.32	0.62
1:C:128:PHE:HA	1:D:103:ALA:HB2	1.82	0.62
1:D:106:GLN:HG2	1:D:151:THR:HA	1.82	0.61
1:E:263:HIS:ND1	5:E:608:HOH:O	2.17	0.61
2:B:355:THR:HG23	2:B:356:HIS:ND1	2.16	0.61
1:F:35:ARG:NH2	5:F:608:HOH:O	2.32	0.61
1:E:287:GLU:HG2	1:E:319:LYS:HG2	1.82	0.60
1:D:302:LEU:HD13	1:D:305:ARG:HH21	1.66	0.60
1:C:65:ASN:OD1	5:C:605:HOH:O	2.17	0.60
1:A:217:HIS:NE2	5:A:507:HOH:O	2.09	0.59
1:D:359:VAL:O	1:D:364:ARG:NH1	2.35	0.59
1:F:185:VAL:HG22	1:F:205:ILE:HB	1.84	0.59
1:G:326:GLU:OE1	1:G:330:LYS:NZ	2.36	0.59
1:A:138:SER:CB	1:A:165:LYS:HZ1	2.16	0.59
2:B:32:TRP:O	2:B:35:ARG:NH1	2.35	0.59
1:F:30:GLU:OE1	5:F:608:HOH:O	2.17	0.59
1:G:10:GLY:N	5:G:620:HOH:O	2.36	0.58
1:D:197:ARG:NH2	5:D:606:HOH:O	2.23	0.58
1:F:361:LYS:HA	1:F:364:ARG:HE	1.68	0.58
1:G:185:VAL:HG22	1:G:205:ILE:HB	1.85	0.57
2:H:73:LYS:NZ	5:H:620:HOH:O	2.36	0.57
2:B:185:VAL:HG22	2:B:205:ILE:HB	1.85	0.57
1:A:350:LEU:HD22	1:A:353:ILE:HG13	1.86	0.57
1:G:190:PHE:O	1:G:311:THR:HG21	2.03	0.57
1:C:190:PHE:O	1:C:311:THR:HG21	2.04	0.57
1:D:268:LYS:HB3	1:D:380:LEU:HD22	1.87	0.57

Continued on next page...

Continued from previous page...

Atom-1	Atom-2	Interatomic distance (Å)	Clash overlap (Å)
1:F:292:PRO:HB3	1:F:303:VAL:HG21	1.86	0.57
1:A:301:GLU:OE1	1:A:305:ARG:NH1	2.37	0.56
1:A:128:PHE:HA	2:B:103:ALA:HB2	1.87	0.55
2:B:57:GLY:HA3	5:D:620:HOH:O	2.06	0.55
1:A:185:VAL:HG22	1:A:205:ILE:HB	1.89	0.55
2:B:104:GLY:N	2:B:129:GLY:O	2.34	0.55
1:D:162:PRO:HB3	1:D:375:ARG:HD3	1.88	0.55
1:A:212:5OW:OP2	2:B:60:TYR:OH	2.19	0.54
1:D:185:VAL:HG22	1:D:205:ILE:HB	1.90	0.54
1:D:190:PHE:O	1:D:311:THR:HG21	2.07	0.54
1:A:168:ASP:OD1	5:A:506:HOH:O	2.17	0.54
2:B:334:LEU:HD23	2:B:386:LEU:HD23	1.90	0.54
2:H:101:LEU:HD22	2:H:152:LYS:HB3	1.89	0.54
2:B:321:THR:HG23	2:B:323:GLN:H	1.73	0.53
1:G:110:MET:HE1	1:G:167:ILE:HD11	1.89	0.53
1:G:330:LYS:HE3	2:H:51:ALA:HA	1.91	0.53
1:E:212:5OW:S11	4:E:501:CYS:N	2.82	0.53
2:H:185:VAL:HG22	2:H:205:ILE:HB	1.90	0.53
1:F:366:VAL:HG23	5:F:603:HOH:O	2.08	0.53
1:A:323:GLN:NE2	1:A:323:GLN:O	2.42	0.53
1:A:34:SER:OG	5:A:503:HOH:O	1.94	0.53
1:A:355:THR:HG23	1:A:356:HIS:ND1	2.24	0.53
1:E:185:VAL:HG22	1:E:205:ILE:HB	1.90	0.53
1:A:253:TYR:OH	1:D:219:ASP:OD2	2.24	0.53
1:D:292:PRO:HB3	1:D:303:VAL:HG21	1.91	0.53
1:C:103:ALA:HB2	1:D:128:PHE:HA	1.92	0.52
1:A:138:SER:HB3	1:A:165:LYS:HZ1	1.73	0.52
1:G:212:5OW:OP2	2:H:62:ARG:NH1	2.42	0.52
1:E:147:ILE:HG21	1:E:179:HIS:ND1	2.24	0.52
1:D:38:VAL:O	5:D:604:HOH:O	2.18	0.52
2:B:157:GLU:HG2	2:B:187:ASP:HB3	1.91	0.52
1:G:119:ARG:NH2	4:G:501:CYS:O	2.34	0.52
1:E:190:PHE:O	1:E:311:THR:HG21	2.10	0.52
1:A:128:PHE:HB3	2:B:128:PHE:HB3	1.91	0.52
1:C:268:LYS:HB3	1:C:380:LEU:HD22	1.92	0.52
1:A:190:PHE:O	1:A:311:THR:HG21	2.10	0.52
1:G:52:PRO:HD3	2:H:330:LYS:NZ	2.25	0.52
2:H:121:PHE:HB3	2:H:132:ILE:HG21	1.91	0.52
1:A:322:LEU:HD11	1:A:353:ILE:HD11	1.91	0.51
1:G:140:ILE:HG12	1:G:175:ILE:HD12	1.91	0.51
1:G:359:VAL:O	1:G:364:ARG:NH1	2.43	0.51

Continued on next page...

Continued from previous page...

Atom-1	Atom-2	Interatomic distance (Å)	Clash overlap (Å)
1:A:23:ILE:HD12	1:D:381:GLU:HG3	1.92	0.51
1:A:384:GLU:HG2	1:A:385:ASP:N	2.26	0.51
2:B:397:ALA:O	2:B:399:PRO:HD3	2.11	0.51
1:A:79:ASP:OD1	1:A:208:TYR:OH	2.18	0.50
2:B:15:PHE:N	5:B:613:HOH:O	2.40	0.50
1:E:400:PRO:O	5:E:609:HOH:O	2.19	0.50
1:F:27:GLN:NE2	1:F:256:ASN:HD21	2.09	0.50
2:H:292:PRO:HB3	2:H:303:VAL:HG21	1.94	0.50
2:H:306:GLN:NE2	5:H:612:HOH:O	2.44	0.50
1:A:29:PRO:O	1:A:35:ARG:HA	2.11	0.50
1:E:139:LYS:HB2	1:E:142:LEU:HD12	1.94	0.50
1:F:366:VAL:N	5:F:603:HOH:O	2.33	0.50
1:A:162:PRO:HD3	1:A:356:HIS:CE1	2.47	0.50
1:E:131:LYS:HD2	5:E:635:HOH:O	2.12	0.50
1:A:110:MET:HE1	1:A:167:ILE:HD11	1.94	0.50
1:E:103:ALA:HB2	1:F:128:PHE:HA	1.94	0.49
2:H:190:PHE:O	2:H:311:THR:HG21	2.11	0.49
1:A:21:GLN:NE2	5:A:524:HOH:O	2.45	0.49
2:B:37:VAL:HG23	2:B:38:VAL:HG13	1.95	0.49
2:H:197:ARG:NH2	5:H:608:HOH:O	2.25	0.49
2:B:106:GLN:HG3	2:B:151:THR:HA	1.94	0.48
1:F:154:VAL:HG23	1:F:182:ILE:HD11	1.95	0.48
1:G:285:TRP:HB3	1:G:399:PRO:HD2	1.94	0.48
2:H:143:LEU:O	2:H:147:ILE:HG13	2.12	0.48
1:D:313:MET:HE1	1:D:375:ARG:HH11	1.78	0.48
2:H:350:LEU:HD22	2:H:353:ILE:HG13	1.96	0.48
1:C:110:MET:HE2	1:C:167:ILE:HD11	1.96	0.48
1:E:317:TYR:CZ	1:E:373:LEU:HD13	2.48	0.48
2:H:334:LEU:HD23	2:H:386:LEU:HD23	1.96	0.48
2:B:253:TYR:OH	1:C:219:ASP:OD2	2.30	0.48
1:C:292:PRO:HB3	1:C:303:VAL:HG21	1.95	0.48
2:H:10:GLY:N	5:H:632:HOH:O	2.47	0.48
1:G:103:ALA:HB2	2:H:128:PHE:HA	1.95	0.48
2:B:369:ILE:HG23	2:B:373:LEU:HD23	1.95	0.48
1:A:69:ASN:O	1:A:73:LYS:HD3	2.14	0.47
1:F:190:PHE:O	1:F:311:THR:HG21	2.14	0.47
2:B:110:MET:HE2	2:B:167:ILE:HD11	1.97	0.47
2:B:161:ASN:HA	2:B:162:PRO:HA	1.76	0.47
1:E:305:ARG:NH1	5:E:612:HOH:O	2.47	0.47
1:A:399:PRO:O	5:A:510:HOH:O	2.20	0.47
1:D:171:GLY:O	1:D:175:ILE:HD12	2.14	0.47

Continued on next page...

Continued from previous page...

Atom-1	Atom-2	Interatomic distance (Å)	Clash overlap (Å)
1:E:106:GLN:HE22	1:E:150:GLU:HB2	1.79	0.47
1:A:191:MET:HG3	1:A:196:GLN:OE1	2.15	0.47
1:A:24:HIS:HE1	1:D:381:GLU:OE1	1.98	0.47
1:C:143:LEU:O	1:C:147:ILE:HG13	2.15	0.47
1:C:321:THR:OG1	1:C:322:LEU:N	2.46	0.47
1:D:106:GLN:HB2	1:D:131:LYS:HB3	1.97	0.47
2:H:79:ASP:OD1	2:H:208:TYR:OH	2.20	0.47
1:A:140:ILE:O	1:A:144:GLU:HG3	2.15	0.47
2:B:292:PRO:HB3	2:B:303:VAL:HG21	1.97	0.47
2:B:317:TYR:CZ	2:B:373:LEU:HD13	2.50	0.47
1:E:292:PRO:HB3	1:E:303:VAL:HG21	1.96	0.47
1:G:317:TYR:CZ	1:G:373:LEU:HD12	2.50	0.47
1:E:79:ASP:OD1	1:E:208:TYR:OH	2.21	0.46
1:E:27:GLN:HE21	1:E:260:LYS:CE	2.29	0.46
1:F:156:ILE:HD12	1:F:184:LEU:HD11	1.97	0.46
1:D:136:ASP:OD1	1:D:138:SER:OG	2.20	0.46
1:E:289:VAL:O	5:E:610:HOH:O	2.20	0.46
1:G:62:ARG:NH1	2:H:212:LLP:OP2	2.48	0.46
1:A:317:TYR:CZ	1:A:373:LEU:HD12	2.51	0.46
2:B:156:ILE:HD11	2:B:186:VAL:HG22	1.97	0.46
1:E:219:ASP:HB2	1:F:43:LEU:HB3	1.98	0.46
1:D:177:HIS:HE1	1:D:202:GLY:O	1.98	0.46
1:A:156:ILE:HD11	1:A:186:VAL:HG22	1.98	0.46
1:F:179:HIS:O	1:F:182:ILE:HG22	2.15	0.46
1:A:114:TYR:OH	3:B:501:SO4:O2	2.23	0.46
1:C:212:5OW:OP2	1:D:62:ARG:NH1	2.48	0.46
1:G:161:ASN:HA	1:G:162:PRO:HA	1.77	0.45
2:B:162:PRO:HB3	2:B:375:ARG:HD3	1.98	0.45
1:D:39:PRO:HA	1:D:40:PRO:HD3	1.85	0.45
1:G:140:ILE:HG12	1:G:175:ILE:CD1	2.46	0.45
1:A:322:LEU:HD13	1:A:371:ASP:HB3	1.99	0.45
1:D:210:ALA:HA	1:D:214:MET:HB2	1.99	0.45
2:H:193:PRO:HD3	2:H:208:TYR:CE2	2.52	0.45
2:H:339:VAL:HG13	2:H:355:THR:HG22	1.99	0.45
2:B:157:GLU:CG	2:B:187:ASP:HB3	2.46	0.45
1:G:212:5OW:OP3	2:H:62:ARG:NH1	2.49	0.45
1:C:369:ILE:HA	1:C:373:LEU:HD13	1.99	0.45
1:G:152:LYS:NZ	5:G:619:HOH:O	2.35	0.45
1:G:193:PRO:HD3	1:G:208:TYR:CE2	2.52	0.45
1:G:364:ARG:NH2	5:G:615:HOH:O	2.34	0.45
2:B:195:PHE:CE2	2:B:266:MET:HB3	2.52	0.45

Continued on next page...

Continued from previous page...

Atom-1	Atom-2	Interatomic distance (Å)	Clash overlap (Å)
1:F:268:LYS:HB3	1:F:380:LEU:HD22	1.99	0.45
1:F:285:TRP:HB3	1:F:398:HIS:CD2	2.52	0.45
1:G:128:PHE:HA	2:H:103:ALA:HB2	1.99	0.45
1:A:381:GLU:OE1	1:D:24:HIS:HE1	2.00	0.44
1:F:197:ARG:NH2	5:F:616:HOH:O	2.37	0.44
1:F:317:TYR:CZ	1:F:373:LEU:HD12	2.52	0.44
1:G:106:GLN:OE1	1:G:151:THR:OG1	2.29	0.44
1:A:171:GLY:N	5:A:506:HOH:O	2.05	0.44
1:E:161:ASN:HA	1:E:162:PRO:HA	1.79	0.44
1:C:339:VAL:HG22	1:C:355:THR:HG23	1.99	0.44
1:E:28:ASP:OD2	5:E:611:HOH:O	2.21	0.44
1:C:162:PRO:HD3	1:C:356:HIS:CE1	2.53	0.44
1:G:157:GLU:HG2	1:G:187:ASP:HB3	2.00	0.44
2:H:106:GLN:HG2	2:H:107:ILE:N	2.32	0.44
1:A:121:PHE:HB3	1:A:132:ILE:HG21	1.98	0.44
1:E:210:ALA:HA	1:E:214:MET:HB2	1.99	0.44
2:H:39:PRO:HA	2:H:40:PRO:HD3	1.90	0.44
1:A:121:PHE:HB3	1:A:132:ILE:HG12	2.00	0.44
1:F:253:TYR:OH	1:G:219:ASP:OD2	2.33	0.44
1:A:373:LEU:HB3	5:A:511:HOH:O	2.17	0.44
1:C:361:LYS:HD3	1:C:364:ARG:NH2	2.33	0.44
1:D:317:TYR:CZ	1:D:373:LEU:HD12	2.52	0.44
1:F:72:GLU:O	1:F:84:CYS:HB3	2.17	0.44
1:C:193:PRO:HD3	1:C:208:TYR:CE2	2.54	0.43
2:H:157:GLU:HB3	2:H:187:ASP:HB3	2.00	0.43
1:A:125:ALA:O	1:A:130:LEU:HB2	2.18	0.43
1:A:360:LEU:O	1:A:364:ARG:HG3	2.17	0.43
1:F:161:ASN:HA	1:F:162:PRO:HA	1.78	0.43
2:B:176:VAL:HG13	2:B:182:ILE:HB	2.01	0.43
1:C:161:ASN:HA	1:C:162:PRO:HA	1.77	0.43
1:C:92:ALA:HB1	1:C:245:ALA:HB1	2.00	0.43
1:E:62:ARG:HD2	1:E:244:GLY:HA2	2.00	0.43
1:A:268:LYS:HB3	1:A:380:LEU:HD22	2.00	0.43
1:A:370:SER:O	5:A:511:HOH:O	2.21	0.43
1:C:39:PRO:HA	1:C:40:PRO:HD3	1.86	0.43
1:C:43:LEU:HB3	1:D:219:ASP:HB2	2.00	0.43
1:E:334:LEU:HA	1:E:334:LEU:HD23	1.85	0.43
2:H:319:LYS:HB2	2:H:399:PRO:HB2	2.01	0.43
1:A:323:GLN:NE2	1:A:327:ILE:HG13	2.33	0.43
2:B:190:PHE:O	2:B:311:THR:HG21	2.18	0.43
2:B:362:ASN:O	2:B:366:VAL:HG23	2.18	0.43

Continued on next page...

Continued from previous page...

Atom-1	Atom-2	Interatomic distance (Å)	Clash overlap (Å)
1:C:28:ASP:HA	1:C:29:PRO:HD3	1.84	0.43
1:C:317:TYR:CZ	1:C:373:LEU:HD12	2.54	0.43
1:E:193:PRO:HD3	1:E:208:TYR:CE2	2.53	0.43
1:G:62:ARG:NH1	2:H:212:LLP:P	2.92	0.43
1:E:60:TYR:HE2	1:E:62:ARG:NH2	2.16	0.43
2:B:269:HIS:NE2	5:B:609:HOH:O	2.37	0.43
1:G:212:5OW:P	2:H:62:ARG:NH1	2.92	0.43
1:G:292:PRO:HB3	1:G:303:VAL:HG21	2.00	0.43
1:G:364:ARG:HB3	1:G:369:ILE:HB	2.00	0.43
1:A:193:PRO:HD3	1:A:208:TYR:CE2	2.54	0.42
2:B:150:GLU:OE1	2:B:150:GLU:N	2.52	0.42
2:H:334:LEU:HA	2:H:334:LEU:HD12	1.87	0.42
1:C:151:THR:O	1:C:182:ILE:HG12	2.18	0.42
1:E:45:THR:HA	1:E:61:SER:HB2	2.01	0.42
1:F:365:ASP:HB2	5:F:603:HOH:O	2.18	0.42
1:E:322:LEU:HB2	1:E:371:ASP:HB3	1.99	0.42
1:D:82:LYS:HA	1:D:82:LYS:HD3	1.63	0.42
1:E:262:LEU:O	1:E:266:MET:HG2	2.19	0.42
1:C:334:LEU:HA	1:C:334:LEU:HD23	1.84	0.42
1:F:28:ASP:HA	1:F:29:PRO:HD2	1.86	0.42
2:H:210:ALA:HA	2:H:214:MET:HB2	2.01	0.42
1:C:304:LYS:HB2	5:C:604:HOH:O	2.20	0.42
1:F:143:LEU:O	1:F:147:ILE:HG13	2.20	0.42
2:H:157:GLU:CB	2:H:187:ASP:HB3	2.50	0.42
2:B:259:LEU:HA	2:B:259:LEU:HD23	1.89	0.42
1:A:39:PRO:HA	1:A:40:PRO:HD3	1.91	0.42
1:G:155:TRP:CZ3	1:G:185:VAL:HG11	2.55	0.42
1:G:268:LYS:HB3	1:G:380:LEU:HD22	2.02	0.41
1:A:11:PHE:CD1	1:A:304:LYS:HG2	2.55	0.41
2:B:151:THR:O	2:B:152:LYS:HD2	2.21	0.41
2:B:45:THR:HA	2:B:61:SER:HB2	2.02	0.41
1:C:112:ASP:HB2	1:C:367:LEU:HD22	2.02	0.41
1:C:73:LYS:NZ	5:C:615:HOH:O	2.37	0.41
1:E:400:PRO:C	5:E:609:HOH:O	2.58	0.41
2:B:262:LEU:O	2:B:266:MET:HG2	2.20	0.41
2:B:55:HIS:CG	2:B:56:SER:H	2.38	0.41
1:G:212:5OW:S11	4:G:501:CYS:HB3	2.60	0.41
1:G:53:GLY:HA3	2:H:353:ILE:HG22	2.01	0.41
1:D:213:TYR:OH	5:D:602:HOH:O	2.13	0.41
1:C:32:TRP:O	1:C:35:ARG:NH1	2.53	0.41
1:D:173:ALA:HA	1:D:184:LEU:HD22	2.02	0.41

Continued on next page...

Continued from previous page...

Atom-1	Atom-2	Interatomic distance (Å)	Clash overlap (Å)
1:D:193:PRO:HD3	1:D:208:TYR:CE2	2.55	0.41
1:C:43:LEU:HD21	1:C:250:ILE:HG12	2.01	0.41
2:H:191:MET:HG3	2:H:196:GLN:OE1	2.21	0.41
2:H:268:LYS:HB3	2:H:380:LEU:HD22	2.03	0.41
1:A:121:PHE:HA	1:A:125:ALA:HB3	2.03	0.41
1:A:334:LEU:HA	1:A:334:LEU:HD23	1.85	0.41
1:G:143:LEU:O	1:G:147:ILE:HG13	2.20	0.41
1:G:259:LEU:HD23	1:G:259:LEU:HA	1.92	0.41
2:H:180:GLY:C	5:H:602:HOH:O	2.53	0.41
1:C:262:LEU:O	1:C:266:MET:HG2	2.20	0.41
1:F:361:LYS:HA	1:F:361:LYS:HD2	1.93	0.41
1:D:112:ASP:HB2	1:D:367:LEU:HD22	2.02	0.41
1:E:75:VAL:HG22	1:E:259:LEU:HD11	2.03	0.41
1:E:39:PRO:HA	1:E:40:PRO:HD3	1.92	0.40
1:F:39:PRO:HA	1:F:40:PRO:HD3	1.92	0.40
1:C:114:TYR:OH	4:C:501:CYS:N	2.37	0.40
2:B:210:ALA:HA	2:B:214:MET:HB2	2.04	0.40
1:F:334:LEU:HD23	1:F:334:LEU:HA	1.78	0.40
1:E:136:ASP:OD1	1:E:138:SER:OG	2.34	0.40
1:E:297:HIS:HA	1:E:298:PRO:HD2	1.88	0.40
1:F:92:ALA:HB1	1:F:245:ALA:HB1	2.03	0.40
1:G:106:GLN:HG2	1:G:107:ILE:N	2.36	0.40
2:H:232:LEU:HA	2:H:232:LEU:HD12	1.94	0.40
2:H:62:ARG:NE	5:H:617:HOH:O	2.43	0.40
1:A:110:MET:HE2	1:A:110:MET:HB3	1.99	0.40
2:B:178:LYS:HE3	2:B:178:LYS:HB2	1.89	0.40
1:D:399:PRO:HA	1:D:400:PRO:HD3	1.97	0.40

There are no symmetry-related clashes.

5.3 Torsion angles [i](#)

5.3.1 Protein backbone [i](#)

In the following table, the Percentiles column shows the percent Ramachandran outliers of the chain as a percentile score with respect to all X-ray entries followed by that with respect to entries of similar resolution.

The Analysed column shows the number of residues for which the backbone conformation was analysed, and the total number of residues.

Mol	Chain	Analysed	Favoured	Allowed	Outliers	Percentiles	
1	A	379/405 (94%)	369 (97%)	8 (2%)	2 (0%)	29	54
1	C	383/405 (95%)	370 (97%)	12 (3%)	1 (0%)	41	66
1	D	382/405 (94%)	369 (97%)	11 (3%)	2 (0%)	29	54
1	E	380/405 (94%)	369 (97%)	10 (3%)	1 (0%)	41	66
1	F	375/405 (93%)	364 (97%)	11 (3%)	0	100	100
1	G	383/405 (95%)	371 (97%)	11 (3%)	1 (0%)	41	66
2	B	379/405 (94%)	368 (97%)	10 (3%)	1 (0%)	41	66
2	H	380/405 (94%)	366 (96%)	13 (3%)	1 (0%)	41	66
All	All	3041/3240 (94%)	2946 (97%)	86 (3%)	9 (0%)	41	66

All (9) Ramachandran outliers are listed below:

Mol	Chain	Res	Type
2	B	180	GLY
1	A	181	ASP
1	D	181	ASP
1	D	192	SER
2	H	192	SER
1	E	192	SER
1	A	192	SER
1	C	192	SER
1	G	192	SER

5.3.2 Protein sidechains [i](#)

In the following table, the Percentiles column shows the percent sidechain outliers of the chain as a percentile score with respect to all X-ray entries followed by that with respect to entries of similar resolution.

The Analysed column shows the number of residues for which the sidechain conformation was analysed, and the total number of residues.

Mol	Chain	Analysed	Rotameric	Outliers	Percentiles	
1	A	326/343 (95%)	324 (99%)	2 (1%)	86	95
1	C	328/343 (96%)	326 (99%)	2 (1%)	86	95
1	D	328/343 (96%)	324 (99%)	4 (1%)	71	88
1	E	327/343 (95%)	327 (100%)	0	100	100
1	F	325/343 (95%)	322 (99%)	3 (1%)	78	92

Continued on next page...

Continued from previous page...

Mol	Chain	Analysed	Rotameric	Outliers	Percentiles	
1	G	328/343 (96%)	327 (100%)	1 (0%)	92	98
2	B	327/343 (95%)	325 (99%)	2 (1%)	86	95
2	H	328/343 (96%)	327 (100%)	1 (0%)	92	98
All	All	2617/2744 (95%)	2602 (99%)	15 (1%)	86	95

All (15) residues with a non-rotameric sidechain are listed below:

Mol	Chain	Res	Type
1	A	165	LYS
1	A	256	ASN
2	B	148	THR
2	B	256	ASN
1	C	256	ASN
1	C	339	VAL
1	D	106	GLN
1	D	140	ILE
1	D	175	ILE
1	D	361	LYS
1	F	102	LYS
1	F	256	ASN
1	F	361	LYS
1	G	102	LYS
2	H	256	ASN

Some sidechains can be flipped to improve hydrogen bonding and reduce clashes. All (11) such sidechains are listed below:

Mol	Chain	Res	Type
1	A	323	GLN
2	B	106	GLN
1	C	27	GLN
1	C	65	ASN
1	D	27	GLN
1	D	196	GLN
1	D	256	ASN
1	F	27	GLN
1	F	398	HIS
1	G	65	ASN
1	G	324	HIS

5.3.3 RNA [i](#)

There are no RNA molecules in this entry.

5.4 Non-standard residues in protein, DNA, RNA chains [i](#)

8 non-standard protein/DNA/RNA residues are modelled in this entry.

In the following table, the Counts columns list the number of bonds (or angles) for which Mogul statistics could be retrieved, the number of bonds (or angles) that are observed in the model and the number of bonds (or angles) that are defined in the Chemical Component Dictionary. The Link column lists molecule types, if any, to which the group is linked. The Z score for a bond length (or angle) is the number of standard deviations the observed value is removed from the expected value. A bond length (or angle) with $|Z| > 2$ is considered an outlier worth inspection. RMSZ is the root-mean-square of all Z scores of the bond lengths (or angles).

Mol	Type	Chain	Res	Link	Bond lengths			Bond angles		
					Counts	RMSZ	# Z > 2	Counts	RMSZ	# Z > 2
1	5OW	G	212	1	26,31,32	0.83	1 (3%)	27,42,44	1.26	2 (7%)
1	5OW	C	212	1	26,31,32	0.85	1 (3%)	27,42,44	1.29	2 (7%)
2	LLP	H	212	2	23,24,25	2.62	5 (21%)	25,32,34	1.26	3 (12%)
1	5OW	E	212	1	26,31,32	0.83	1 (3%)	27,42,44	1.25	3 (11%)
1	5OW	F	212	1	26,31,32	0.85	1 (3%)	27,42,44	1.13	2 (7%)
2	LLP	B	212	2	23,24,25	2.62	7 (30%)	25,32,34	1.24	4 (16%)
1	5OW	D	212	1	26,31,32	0.88	1 (3%)	27,42,44	1.27	3 (11%)
1	5OW	A	212	1	26,31,32	0.84	1 (3%)	27,42,44	1.20	3 (11%)

In the following table, the Chirals column lists the number of chiral outliers, the number of chiral centers analysed, the number of these observed in the model and the number defined in the Chemical Component Dictionary. Similar counts are reported in the Torsion and Rings columns. '-' means no outliers of that kind were identified.

Mol	Type	Chain	Res	Link	Chirals	Torsions	Rings
1	5OW	G	212	1	-	10/25/30/32	0/1/1/1
1	5OW	C	212	1	-	8/25/30/32	0/1/1/1
2	LLP	H	212	2	-	6/16/17/19	0/1/1/1
1	5OW	E	212	1	-	11/25/30/32	0/1/1/1
1	5OW	F	212	1	-	11/25/30/32	0/1/1/1
2	LLP	B	212	2	-	6/16/17/19	0/1/1/1
1	5OW	D	212	1	-	10/25/30/32	0/1/1/1
1	5OW	A	212	1	-	10/25/30/32	0/1/1/1

All (18) bond length outliers are listed below:

Mol	Chain	Res	Type	Atoms	Z	Observed(Å)	Ideal(Å)
2	H	212	LLP	C4-C4'	8.10	1.62	1.46
2	B	212	LLP	C4-C4'	8.08	1.62	1.46
2	B	212	LLP	C4'-NZ	4.99	1.44	1.27
2	H	212	LLP	C4'-NZ	4.96	1.43	1.27
2	H	212	LLP	C4-C5	-4.15	1.36	1.42
2	B	212	LLP	C4-C5	-4.00	1.36	1.42
2	B	212	LLP	C2'-C2	3.51	1.56	1.50
2	H	212	LLP	C2'-C2	3.45	1.56	1.50
2	B	212	LLP	C6-N1	2.98	1.40	1.34
2	H	212	LLP	C6-N1	2.95	1.40	1.34
1	C	212	5OW	C3-C2	-2.40	1.38	1.40
1	D	212	5OW	C3-C2	-2.34	1.38	1.40
1	F	212	5OW	C3-C2	-2.28	1.38	1.40
1	A	212	5OW	C3-C2	-2.23	1.38	1.40
1	G	212	5OW	C3-C2	-2.19	1.38	1.40
1	E	212	5OW	C3-C2	-2.17	1.38	1.40
2	B	212	LLP	C5'-C5	2.04	1.56	1.50
2	B	212	LLP	C3-C2	2.00	1.42	1.40

All (22) bond angle outliers are listed below:

Mol	Chain	Res	Type	Atoms	Z	Observed(°)	Ideal(°)
2	B	212	LLP	C4-C4'-NZ	-3.40	108.71	124.31
2	H	212	LLP	C4-C4'-NZ	-3.30	109.15	124.31
1	G	212	5OW	C1-C10-S11	-2.83	111.08	114.24
2	H	212	LLP	CE-NZ-C4'	-2.76	110.44	118.90
1	C	212	5OW	C4-C4'-NZ	2.67	122.38	115.76
1	C	212	5OW	C1-C10-S11	-2.60	111.33	114.24
2	B	212	LLP	CE-NZ-C4'	-2.59	110.94	118.90
1	G	212	5OW	C4-C4'-NZ	2.55	122.07	115.76
1	F	212	5OW	C4-C4'-NZ	2.51	121.99	115.76
1	D	212	5OW	C5-C6-N1	-2.46	119.73	123.82
2	H	212	LLP	C5-C6-N1	-2.40	119.81	123.82
1	A	212	5OW	C4-C4'-NZ	2.31	121.49	115.76
1	E	212	5OW	C5-C6-N1	-2.29	120.00	123.82
1	E	212	5OW	C4-C4'-NZ	2.25	121.33	115.76
1	A	212	5OW	C5-C6-N1	-2.24	120.08	123.82
2	B	212	LLP	C5-C6-N1	-2.19	120.17	123.82
1	A	212	5OW	CD-CE-NZ	-2.19	105.95	112.21
1	D	212	5OW	C4-C4'-NZ	2.15	121.08	115.76
1	D	212	5OW	CD-CE-NZ	-2.12	106.15	112.21
1	F	212	5OW	C5-C6-N1	-2.11	120.31	123.82

Continued on next page...

Continued from previous page...

Mol	Chain	Res	Type	Atoms	Z	Observed(°)	Ideal(°)
1	E	212	5OW	CD-CE-NZ	-2.09	106.23	112.21
2	B	212	LLP	C3-C4-C5	2.06	119.84	118.26

There are no chirality outliers.

All (72) torsion outliers are listed below:

Mol	Chain	Res	Type	Atoms
1	G	212	5OW	C-CA-CB-CG
1	G	212	5OW	O-C-CA-CB
1	G	212	5OW	N4-C4'-NZ-CE
1	C	212	5OW	O-C-CA-CB
1	C	212	5OW	C7-C1-C10-S11
1	C	212	5OW	N4-C1-C10-S11
1	C	212	5OW	N4-C4'-NZ-CE
2	H	212	LLP	C4-C4'-NZ-CE
2	H	212	LLP	O-C-CA-CB
1	E	212	5OW	C-CA-CB-CG
1	E	212	5OW	O-C-CA-CB
1	E	212	5OW	C7-C1-C10-S11
1	E	212	5OW	N4-C1-C10-S11
1	E	212	5OW	N4-C4'-NZ-CE
1	E	212	5OW	C5'-OP4-P-OP3
1	E	212	5OW	C5'-OP4-P-OP2
1	E	212	5OW	C5'-OP4-P-OP1
1	F	212	5OW	C-CA-CB-CG
1	F	212	5OW	O-C-CA-CB
1	F	212	5OW	N4-C1-C10-S11
1	F	212	5OW	N4-C4'-NZ-CE
1	F	212	5OW	C5'-OP4-P-OP3
1	F	212	5OW	C5'-OP4-P-OP2
1	F	212	5OW	C5'-OP4-P-OP1
2	B	212	LLP	C4-C4'-NZ-CE
2	B	212	LLP	O-C-CA-CB
1	D	212	5OW	C-CA-CB-CG
1	D	212	5OW	O-C-CA-CB
1	D	212	5OW	N4-C4'-NZ-CE
1	D	212	5OW	C5'-OP4-P-OP3
1	D	212	5OW	C5'-OP4-P-OP2
1	D	212	5OW	C5'-OP4-P-OP1
1	A	212	5OW	C-CA-CB-CG
1	A	212	5OW	O-C-CA-CB
1	A	212	5OW	N4-C4'-NZ-CE

Continued on next page...

Continued from previous page...

Mol	Chain	Res	Type	Atoms
1	A	212	5OW	C5'-OP4-P-OP3
1	A	212	5OW	C5'-OP4-P-OP2
1	A	212	5OW	C5'-OP4-P-OP1
1	C	212	5OW	CG-CD-CE-NZ
1	A	212	5OW	CG-CD-CE-NZ
1	G	212	5OW	CG-CD-CE-NZ
1	E	212	5OW	CG-CD-CE-NZ
1	F	212	5OW	CG-CD-CE-NZ
1	D	212	5OW	CG-CD-CE-NZ
2	B	212	LLP	CG-CD-CE-NZ
1	C	212	5OW	CE-CD-CG-CB
1	D	212	5OW	CE-CD-CG-CB
1	F	212	5OW	CE-CD-CG-CB
1	E	212	5OW	CE-CD-CG-CB
1	A	212	5OW	CE-CD-CG-CB
1	G	212	5OW	CE-CD-CG-CB
1	G	212	5OW	C5'-OP4-P-OP3
1	G	212	5OW	C4-C4'-NZ-CE
1	C	212	5OW	C4-C4'-NZ-CE
1	E	212	5OW	C4-C4'-NZ-CE
1	F	212	5OW	C4-C4'-NZ-CE
1	D	212	5OW	C4-C4'-NZ-CE
1	A	212	5OW	C4-C4'-NZ-CE
2	H	212	LLP	CA-CB-CG-CD
2	H	212	LLP	N-CA-CB-CG
2	B	212	LLP	N-CA-CB-CG
1	G	212	5OW	N4-C1-C10-S11
1	D	212	5OW	N4-C1-C10-S11
1	A	212	5OW	N4-C1-C10-S11
2	H	212	LLP	C3-C4-C4'-NZ
2	B	212	LLP	CA-CB-CG-CD
2	H	212	LLP	CD-CE-NZ-C4'
2	B	212	LLP	CD-CE-NZ-C4'
1	G	212	5OW	C5'-OP4-P-OP1
1	F	212	5OW	C7-C1-C10-S11
1	C	212	5OW	C-CA-CB-CG
1	G	212	5OW	C5'-OP4-P-OP2

There are no ring outliers.

7 monomers are involved in 14 short contacts:

Mol	Chain	Res	Type	Clashes	Symm-Clashes
1	G	212	5OW	4	0
1	C	212	5OW	2	0
2	H	212	LLP	4	0
1	E	212	5OW	1	0
1	F	212	5OW	1	0
2	B	212	LLP	1	0
1	A	212	5OW	1	0

5.5 Carbohydrates [i](#)

There are no carbohydrates in this entry.

5.6 Ligand geometry [i](#)

8 ligands are modelled in this entry.

In the following table, the Counts columns list the number of bonds (or angles) for which Mogul statistics could be retrieved, the number of bonds (or angles) that are observed in the model and the number of bonds (or angles) that are defined in the Chemical Component Dictionary. The Link column lists molecule types, if any, to which the group is linked. The Z score for a bond length (or angle) is the number of standard deviations the observed value is removed from the expected value. A bond length (or angle) with $|Z| > 2$ is considered an outlier worth inspection. RMSZ is the root-mean-square of all Z scores of the bond lengths (or angles).

Mol	Type	Chain	Res	Link	Bond lengths			Bond angles		
					Counts	RMSZ	$\# Z > 2$	Counts	RMSZ	$\# Z > 2$
3	SO4	D	501	-	4,4,4	0.14	0	6,6,6	0.04	0
3	SO4	B	502	-	4,4,4	0.13	0	6,6,6	0.08	0
3	SO4	F	501	-	4,4,4	0.14	0	6,6,6	0.06	0
3	SO4	H	501	-	4,4,4	0.15	0	6,6,6	0.08	0
3	SO4	B	501	-	4,4,4	0.14	0	6,6,6	0.06	0

There are no bond length outliers.

There are no bond angle outliers.

There are no chirality outliers.

There are no torsion outliers.

There are no ring outliers.

2 monomers are involved in 2 short contacts:

Mol	Chain	Res	Type	Clashes	Symm-Clashes
3	B	502	SO4	1	0
3	B	501	SO4	1	0

5.7 Other polymers [i](#)

There are no such residues in this entry.

5.8 Polymer linkage issues [i](#)

There are no chain breaks in this entry.

6 Fit of model and data

6.1 Protein, DNA and RNA chains

In the following table, the column labelled ‘#RSRZ> 2’ contains the number (and percentage) of RSRZ outliers, followed by percent RSRZ outliers for the chain as percentile scores relative to all X-ray entries and entries of similar resolution. The OWAB column contains the minimum, median, 95th percentile and maximum values of the occupancy-weighted average B-factor per residue. The column labelled ‘Q< 0.9’ lists the number of (and percentage) of residues with an average occupancy less than 0.9.

Mol	Chain	Analysed	<RSRZ>	#RSRZ>2	OWAB(Å ²)	Q<0.9
1	A	383/405 (94%)	-0.05	7 (1%) 68 70	17, 32, 73, 96	0
1	C	387/405 (95%)	0.14	15 (3%) 39 38	16, 36, 67, 87	0
1	D	386/405 (95%)	0.02	14 (3%) 42 42	16, 34, 73, 91	0
1	E	384/405 (94%)	-0.28	0 100 100	13, 23, 47, 72	0
1	F	381/405 (94%)	0.02	13 (3%) 45 45	12, 29, 67, 90	0
1	G	387/405 (95%)	-0.40	4 (1%) 82 83	11, 21, 43, 65	0
2	B	385/405 (95%)	0.45	26 (6%) 17 15	21, 43, 78, 98	0
2	H	386/405 (95%)	0.08	17 (4%) 34 33	13, 28, 57, 76	0
All	All	3079/3240 (95%)	-0.00	96 (3%) 49 49	11, 30, 68, 98	0

All (96) RSRZ outliers are listed below:

Mol	Chain	Res	Type	RSRZ
2	B	140	ILE	5.6
2	B	144	GLU	4.9
2	H	51	ALA	4.8
1	C	399	PRO	4.8
1	F	399	PRO	4.8
2	H	16	GLN	4.7
2	H	400	PRO	4.5
2	B	397	ALA	4.2
2	B	399	PRO	4.1
1	C	129	GLY	3.8
1	C	387	LEU	3.8
1	D	362	ASN	3.6
1	F	397	ALA	3.6
2	H	394	LEU	3.6
2	B	14	HIS	3.5
1	F	363	ASP	3.3

Continued on next page...

Continued from previous page...

Mol	Chain	Res	Type	RSRZ
1	D	129	GLY	3.3
2	B	143	LEU	3.3
2	H	284	PRO	3.3
1	F	366	VAL	3.2
1	D	181	ASP	3.2
1	A	362	ASN	3.1
2	B	180	GLY	3.1
1	D	359	VAL	3.1
1	G	53	GLY	3.1
2	H	285	TRP	3.1
1	F	285	TRP	3.0
2	H	181	ASP	3.0
1	D	16	GLN	3.0
2	B	148	THR	3.0
2	H	322	LEU	2.9
1	C	321	THR	2.9
1	F	323	GLN	2.9
2	H	398	HIS	2.8
2	H	399	PRO	2.8
2	H	290	ILE	2.8
2	H	371	ASP	2.8
1	D	146	ALA	2.7
1	C	181	ASP	2.7
2	B	323	GLN	2.7
1	C	285	TRP	2.7
2	H	286	VAL	2.7
2	B	15	PHE	2.6
1	G	30	GLU	2.5
2	B	363	ASP	2.5
1	F	367	LEU	2.5
1	C	325	ALA	2.5
1	G	51	ALA	2.5
2	B	138	SER	2.5
1	F	322	LEU	2.5
1	A	111	ASP	2.5
1	C	320	GLY	2.4
2	B	294	LEU	2.4
1	C	386	LEU	2.4
2	H	390	LEU	2.4
1	D	358	SER	2.4
1	A	104	GLY	2.4
2	B	13	PRO	2.4

Continued on next page...

Continued from previous page...

Mol	Chain	Res	Type	RSRZ
1	A	371	ASP	2.4
2	B	279	PHE	2.4
2	B	301	GLU	2.4
1	F	362	ASN	2.4
1	C	149	PRO	2.3
1	A	323	GLN	2.3
1	C	323	GLN	2.3
2	B	139	LYS	2.3
2	B	174	HIS	2.3
2	H	367	LEU	2.3
2	B	362	ASN	2.3
1	F	353	ILE	2.3
1	C	179	HIS	2.3
1	C	362	ASN	2.3
2	B	286	VAL	2.2
2	H	141	LYS	2.2
1	D	175	ILE	2.2
2	B	16	GLN	2.2
2	B	295	PRO	2.2
1	D	144	GLU	2.2
1	A	357	ALA	2.2
2	B	147	ILE	2.1
1	D	174	HIS	2.1
1	D	56	SER	2.1
1	G	54	GLN	2.1
1	C	318	ILE	2.1
1	D	360	LEU	2.1
1	F	371	ASP	2.1
1	A	384	GLU	2.1
2	B	293	GLY	2.1
2	B	285	TRP	2.0
1	D	140	ILE	2.0
2	H	56	SER	2.0
1	C	394	LEU	2.0
1	F	140	ILE	2.0
2	B	173	ALA	2.0
1	F	398	HIS	2.0
1	D	131	LYS	2.0

6.2 Non-standard residues in protein, DNA, RNA chains [i](#)

In the following table, the Atoms column lists the number of modelled atoms in the group and the number defined in the chemical component dictionary. The B-factors column lists the minimum, median, 95th percentile and maximum values of B factors of atoms in the group. The column labelled 'Q< 0.9' lists the number of atoms with occupancy less than 0.9.

Mol	Type	Chain	Res	Atoms	RSCC	RSR	B-factors(Å ²)	Q<0.9
1	5OW	G	212	31/32	0.94	0.19	11,19,31,52	3
1	5OW	C	212	31/32	0.94	0.24	23,37,45,53	3
1	5OW	E	212	31/32	0.94	0.21	12,23,28,34	3
1	5OW	F	212	31/32	0.94	0.20	16,24,43,52	3
2	LLP	B	212	24/25	0.94	0.17	29,35,44,46	0
1	5OW	D	212	31/32	0.94	0.16	15,32,39,50	2
1	5OW	A	212	31/32	0.95	0.16	18,28,36,37	4
2	LLP	H	212	24/25	0.96	0.15	18,23,27,28	0

6.3 Carbohydrates [i](#)

There are no carbohydrates in this entry.

6.4 Ligands [i](#)

In the following table, the Atoms column lists the number of modelled atoms in the group and the number defined in the chemical component dictionary. The B-factors column lists the minimum, median, 95th percentile and maximum values of B factors of atoms in the group. The column labelled 'Q< 0.9' lists the number of atoms with occupancy less than 0.9.

Mol	Type	Chain	Res	Atoms	RSCC	RSR	B-factors(Å ²)	Q<0.9
4	CYS	G	501	7/7	0.84	0.22	23,25,36,67	0
4	CYS	E	501	7/7	0.88	0.28	33,34,51,100	0
4	CYS	C	501	7/7	0.90	0.16	43,46,57,70	0
3	SO4	B	502	5/5	0.91	0.16	54,58,70,76	0
3	SO4	D	501	5/5	0.94	0.14	54,56,61,73	0
3	SO4	H	501	5/5	0.94	0.15	38,41,60,72	0
3	SO4	F	501	5/5	0.95	0.12	35,37,55,66	0
3	SO4	B	501	5/5	0.95	0.15	47,52,69,75	0

6.5 Other polymers [i](#)

There are no such residues in this entry.