



## Full wwPDB EM Validation Report ⓘ

Jan 7, 2025 – 03:30 pm GMT

PDB ID : 9GAT  
EMDB ID : EMD-51188  
Title : CryoEM structure of the antiparallel double-stranded influenza A RNP-like particle with a 18-mer RNA.  
Authors : Chenavier, F.; Ruigrok, R.W.H.; Schoehn, G.; Ballandras-Colas, A.; Crepin, T.  
Deposited on : 2024-07-29  
Resolution : 3.20 Å(reported)

This is a Full wwPDB EM Validation Report for a publicly released PDB entry.

We welcome your comments at [validation@mail.wwpdb.org](mailto:validation@mail.wwpdb.org)

A user guide is available at

<https://www.wwpdb.org/validation/2017/EMValidationReportHelp>

with specific help available everywhere you see the ⓘ symbol.

The types of validation reports are described at

<http://www.wwpdb.org/validation/2017/FAQs#types>.

---

The following versions of software and data (see [references ⓘ](#)) were used in the production of this report:

EMDB validation analysis : 0.0.1.dev113  
Mogul : 1.8.4, CSD as541be (2020)  
MolProbity : 4.02b-467  
buster-report : 1.1.7 (2018)  
Percentile statistics : 20231227.v01 (using entries in the PDB archive December 27th 2023)  
MapQ : 1.9.13  
Ideal geometry (proteins) : Engh & Huber (2001)  
Ideal geometry (DNA, RNA) : Parkinson et al. (1996)  
Validation Pipeline (wwPDB-VP) : 2.40

# 1 Overall quality at a glance i

The following experimental techniques were used to determine the structure:  
*ELECTRON MICROSCOPY*

The reported resolution of this entry is 3.20 Å.

Percentile scores (ranging between 0-100) for global validation metrics of the entry are shown in the following graphic. The table shows the number of entries on which the scores are based.

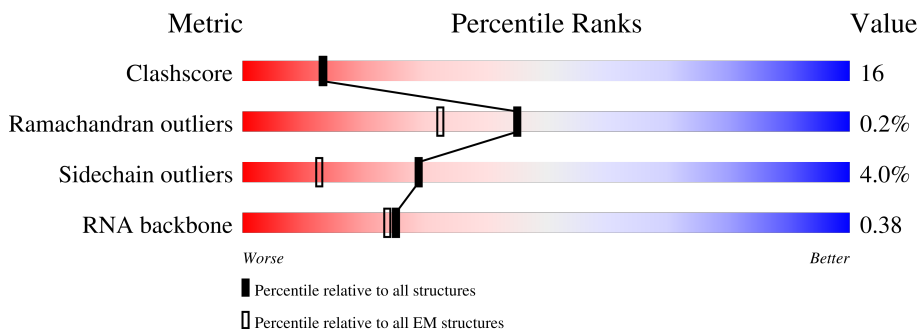







Metric	Whole archive (#Entries)	EM structures (#Entries)
Clashscore	210492	15764
Ramachandran outliers	207382	16835
Sidechain outliers	206894	16415
RNA backbone	6643	2191

The table below summarises the geometric issues observed across the polymeric chains and their fit to the map. The red, orange, yellow and green segments of the bar indicate the fraction of residues that contain outliers for  $\geq 3$ , 2, 1 and 0 types of geometric quality criteria respectively. A grey segment represents the fraction of residues that are not modelled. The numeric value for each fraction is indicated below the corresponding segment, with a dot representing fractions  $\leq 5\%$ . The upper red bar (where present) indicates the fraction of residues that have poor fit to the EM map (all-atom inclusion  $< 40\%$ ). The numeric value is given above the bar.

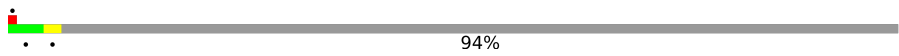
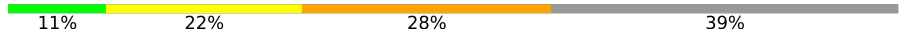
Mol	Chain	Length	Quality of chain
1	A	494	
1	B	494	
1	C	494	
1	D	494	
1	I	494	
1	J	494	
1	K	494	

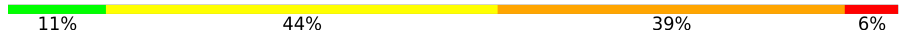
Continued on next page...

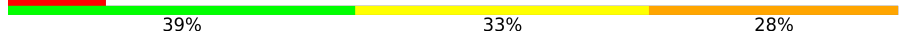
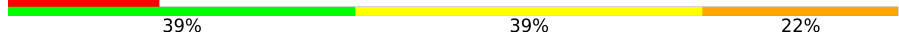
*Continued from previous page...*

Mol	Chain	Length	Quality of chain
1	L	494	 94%
2	E	18	 11% 22% 28% 39%
2	F	18	 17% 44% 33% 6%
2	G	18	 11% 44% 39% 6%
2	H	18	 6% 22% 11% 61%
2	M	18	 17% 28% 17% 17% 39%
2	N	18	 11% 39% 33% 28%
2	O	18	 17% 39% 39% 22%
2	P	18	 17% 22% 61%

## 2 Entry composition i

There are 3 unique types of molecules in this entry. The entry contains 24208 atoms, of which 10 are hydrogens and 0 are deuteriums.

In the tables below, the AltConf column contains the number of residues with at least one atom in alternate conformation and the Trace column contains the number of residues modelled with at most 2 atoms.

- Molecule 1 is a protein called Nucleoprotein.

Mol	Chain	Residues	Atoms					AltConf	Trace
			Total	C	N	O	S		
1	L	28	219	140	38	40	1	0	0
1	D	26	206	133	36	36	1	0	0
1	K	462	3666	2271	686	683	26	0	0
1	J	462	3666	2271	686	683	26	0	0
1	I	434	3447	2131	648	643	25	0	0
1	B	454	3606	2239	676	666	25	0	0
1	A	428	3400	2106	640	630	24	0	0
1	C	454	3606	2239	676	666	25	0	0

There are 80 discrepancies between the modelled and reference sequences:

Chain	Residue	Modelled	Actual	Comment	Reference
L	13	HIS	-	expression tag	UNP Q1K9H2
L	14	MET	-	expression tag	UNP Q1K9H2
L	499	LEU	-	expression tag	UNP Q1K9H2
L	500	GLU	-	expression tag	UNP Q1K9H2
L	501	HIS	-	expression tag	UNP Q1K9H2
L	502	HIS	-	expression tag	UNP Q1K9H2
L	503	HIS	-	expression tag	UNP Q1K9H2
L	504	HIS	-	expression tag	UNP Q1K9H2
L	505	HIS	-	expression tag	UNP Q1K9H2
L	506	HIS	-	expression tag	UNP Q1K9H2
D	13	HIS	-	expression tag	UNP Q1K9H2
D	14	MET	-	expression tag	UNP Q1K9H2
D	499	LEU	-	expression tag	UNP Q1K9H2
D	500	GLU	-	expression tag	UNP Q1K9H2

*Continued on next page...*

*Continued from previous page...*

Chain	Residue	Modelled	Actual	Comment	Reference
D	501	HIS	-	expression tag	UNP Q1K9H2
D	502	HIS	-	expression tag	UNP Q1K9H2
D	503	HIS	-	expression tag	UNP Q1K9H2
D	504	HIS	-	expression tag	UNP Q1K9H2
D	505	HIS	-	expression tag	UNP Q1K9H2
D	506	HIS	-	expression tag	UNP Q1K9H2
K	13	HIS	-	expression tag	UNP Q1K9H2
K	14	MET	-	expression tag	UNP Q1K9H2
K	499	LEU	-	expression tag	UNP Q1K9H2
K	500	GLU	-	expression tag	UNP Q1K9H2
K	501	HIS	-	expression tag	UNP Q1K9H2
K	502	HIS	-	expression tag	UNP Q1K9H2
K	503	HIS	-	expression tag	UNP Q1K9H2
K	504	HIS	-	expression tag	UNP Q1K9H2
K	505	HIS	-	expression tag	UNP Q1K9H2
K	506	HIS	-	expression tag	UNP Q1K9H2
J	13	HIS	-	expression tag	UNP Q1K9H2
J	14	MET	-	expression tag	UNP Q1K9H2
J	499	LEU	-	expression tag	UNP Q1K9H2
J	500	GLU	-	expression tag	UNP Q1K9H2
J	501	HIS	-	expression tag	UNP Q1K9H2
J	502	HIS	-	expression tag	UNP Q1K9H2
J	503	HIS	-	expression tag	UNP Q1K9H2
J	504	HIS	-	expression tag	UNP Q1K9H2
J	505	HIS	-	expression tag	UNP Q1K9H2
J	506	HIS	-	expression tag	UNP Q1K9H2
I	13	HIS	-	expression tag	UNP Q1K9H2
I	14	MET	-	expression tag	UNP Q1K9H2
I	499	LEU	-	expression tag	UNP Q1K9H2
I	500	GLU	-	expression tag	UNP Q1K9H2
I	501	HIS	-	expression tag	UNP Q1K9H2
I	502	HIS	-	expression tag	UNP Q1K9H2
I	503	HIS	-	expression tag	UNP Q1K9H2
I	504	HIS	-	expression tag	UNP Q1K9H2
I	505	HIS	-	expression tag	UNP Q1K9H2
I	506	HIS	-	expression tag	UNP Q1K9H2
B	13	HIS	-	expression tag	UNP Q1K9H2
B	14	MET	-	expression tag	UNP Q1K9H2
B	499	LEU	-	expression tag	UNP Q1K9H2
B	500	GLU	-	expression tag	UNP Q1K9H2
B	501	HIS	-	expression tag	UNP Q1K9H2
B	502	HIS	-	expression tag	UNP Q1K9H2

*Continued on next page...*

Continued from previous page...

Chain	Residue	Modelled	Actual	Comment	Reference
B	503	HIS	-	expression tag	UNP Q1K9H2
B	504	HIS	-	expression tag	UNP Q1K9H2
B	505	HIS	-	expression tag	UNP Q1K9H2
B	506	HIS	-	expression tag	UNP Q1K9H2
A	13	HIS	-	expression tag	UNP Q1K9H2
A	14	MET	-	expression tag	UNP Q1K9H2
A	499	LEU	-	expression tag	UNP Q1K9H2
A	500	GLU	-	expression tag	UNP Q1K9H2
A	501	HIS	-	expression tag	UNP Q1K9H2
A	502	HIS	-	expression tag	UNP Q1K9H2
A	503	HIS	-	expression tag	UNP Q1K9H2
A	504	HIS	-	expression tag	UNP Q1K9H2
A	505	HIS	-	expression tag	UNP Q1K9H2
A	506	HIS	-	expression tag	UNP Q1K9H2
C	13	HIS	-	expression tag	UNP Q1K9H2
C	14	MET	-	expression tag	UNP Q1K9H2
C	499	LEU	-	expression tag	UNP Q1K9H2
C	500	GLU	-	expression tag	UNP Q1K9H2
C	501	HIS	-	expression tag	UNP Q1K9H2
C	502	HIS	-	expression tag	UNP Q1K9H2
C	503	HIS	-	expression tag	UNP Q1K9H2
C	504	HIS	-	expression tag	UNP Q1K9H2
C	505	HIS	-	expression tag	UNP Q1K9H2
C	506	HIS	-	expression tag	UNP Q1K9H2

- Molecule 2 is a RNA chain called RNA (5'-P(UC)9-FAM3').

Mol	Chain	Residues	Atoms					AltConf	Trace
			Total	C	N	O	P		
2	O	18	Total 361	C 162	N 45	O 136	P 18	0	0
2	P	7	Total 141	C 63	N 17	O 54	P 7	0	0
2	M	11	Total 220	C 99	N 28	O 82	P 11	0	0
2	N	18	Total 361	C 162	N 45	O 136	P 18	0	0
2	E	11	Total 220	C 99	N 28	O 82	P 11	0	0
2	F	18	Total 361	C 162	N 45	O 136	P 18	0	0
2	G	18	Total 361	C 162	N 45	O 136	P 18	0	0

Continued on next page...

Continued from previous page...

Mol	Chain	Residues	Atoms					AltConf	Trace	
			Total	C	H	N	O			P
2	H	7	151	63	10	17	54	7	0	0

- Molecule 3 is 2-[3,6-bis(oxidanylidene)-4,5-dihydroxanthren-9-yl]-4-[3-[(2R)-2-oxidanylpropoxy]propylcarbamoyl]benzoic acid (three-letter code: A1IJK) (formula: C<sub>27</sub>H<sub>27</sub>NO<sub>8</sub>).

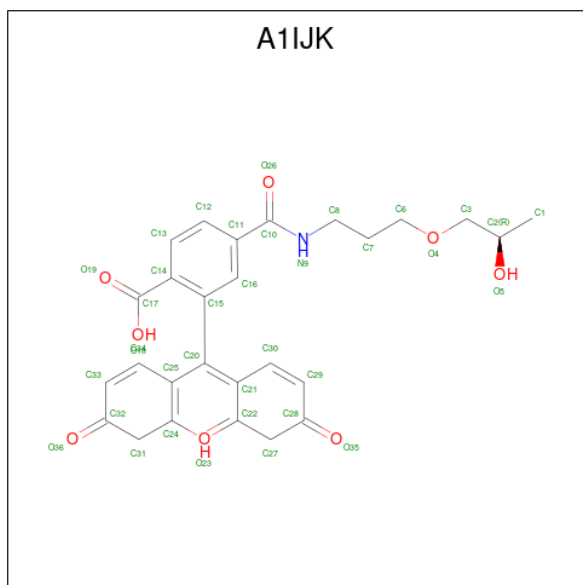

Mol	Chain	Residues	Atoms				AltConf
			Total	C	N	O	
3	O	1	36	27	1	8	0
3	M	1	36	27	1	8	0
3	N	1	36	27	1	8	0
3	E	1	36	27	1	8	0
3	F	1	36	27	1	8	0
3	G	1	36	27	1	8	0

### 3 Residue-property plots [i](#)

These plots are drawn for all protein, RNA, DNA and oligosaccharide chains in the entry. The first graphic for a chain summarises the proportions of the various outlier classes displayed in the second graphic. The second graphic shows the sequence view annotated by issues in geometry and atom inclusion in map density. Residues are color-coded according to the number of geometric quality criteria for which they contain at least one outlier: green = 0, yellow = 1, orange = 2 and red = 3 or more. A red diamond above a residue indicates a poor fit to the EM map for this residue (all-atom inclusion < 40%). Stretches of 2 or more consecutive residues without any outlier are shown as a green connector. Residues present in the sample, but not in the model, are shown in grey.

- Molecule 1: Nucleoprotein

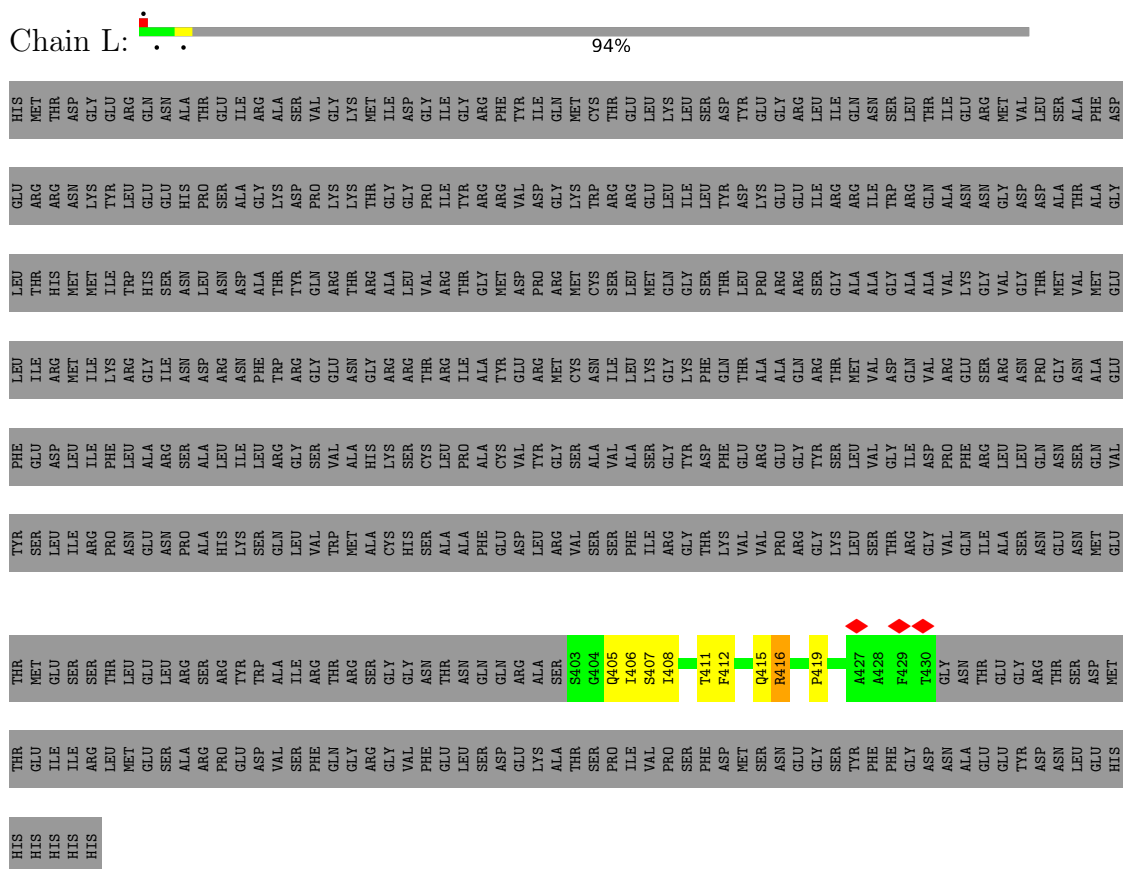

- Molecule 1: Nucleoprotein

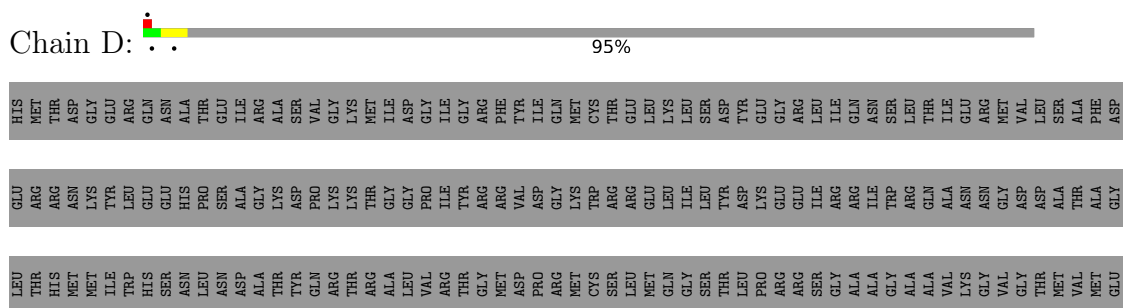



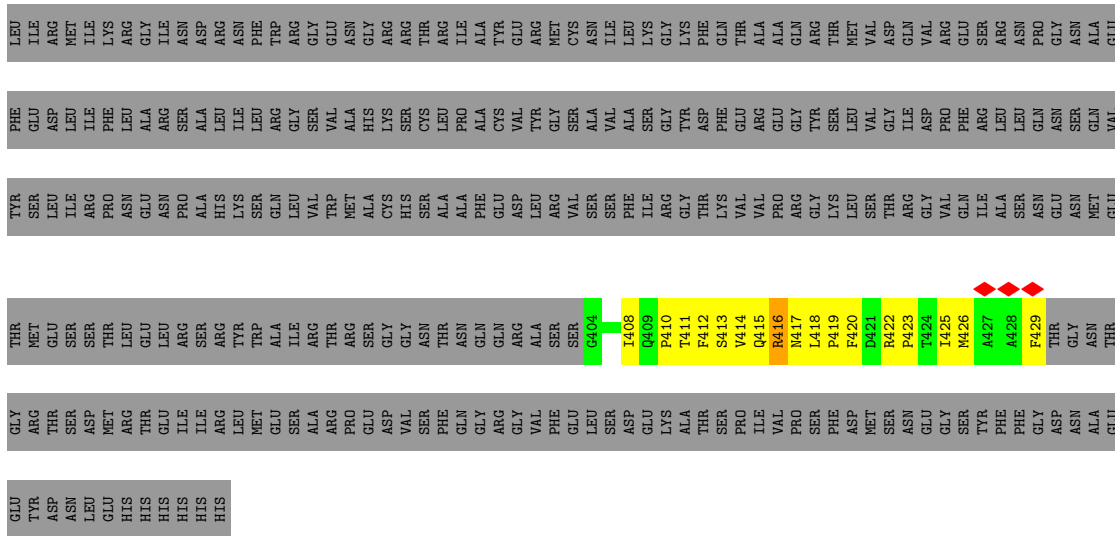

• Molecule 1: Nucleoprotein

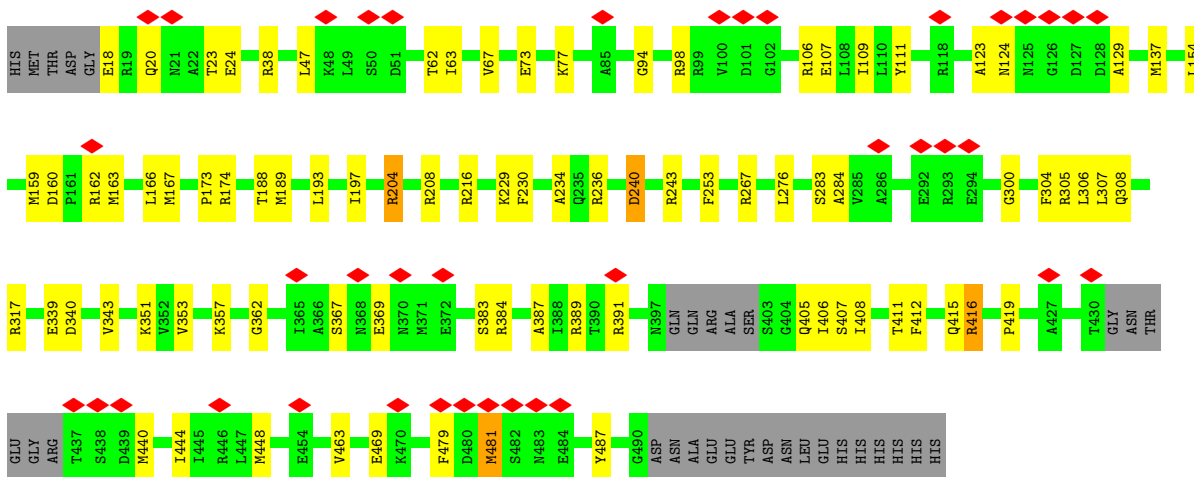
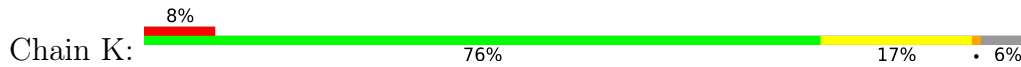

• Molecule 1: Nucleoprotein

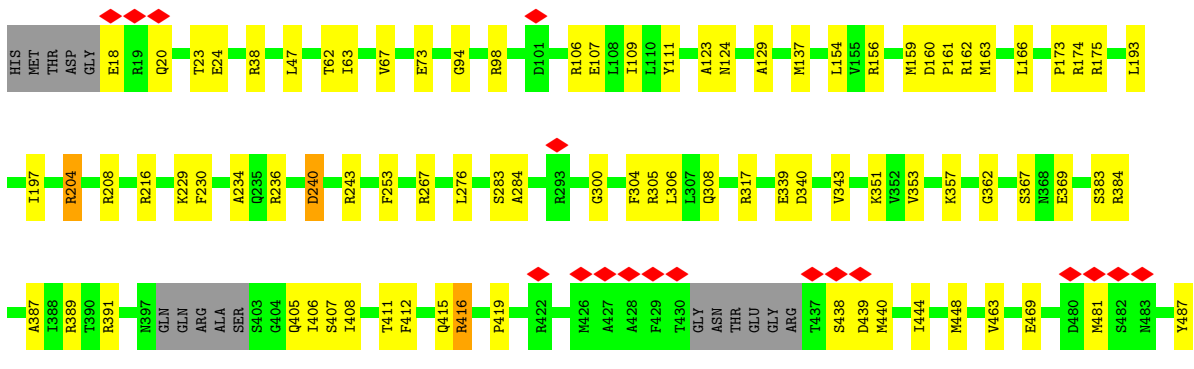
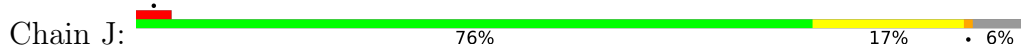

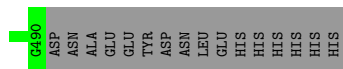

• Molecule 1: Nucleoprotein

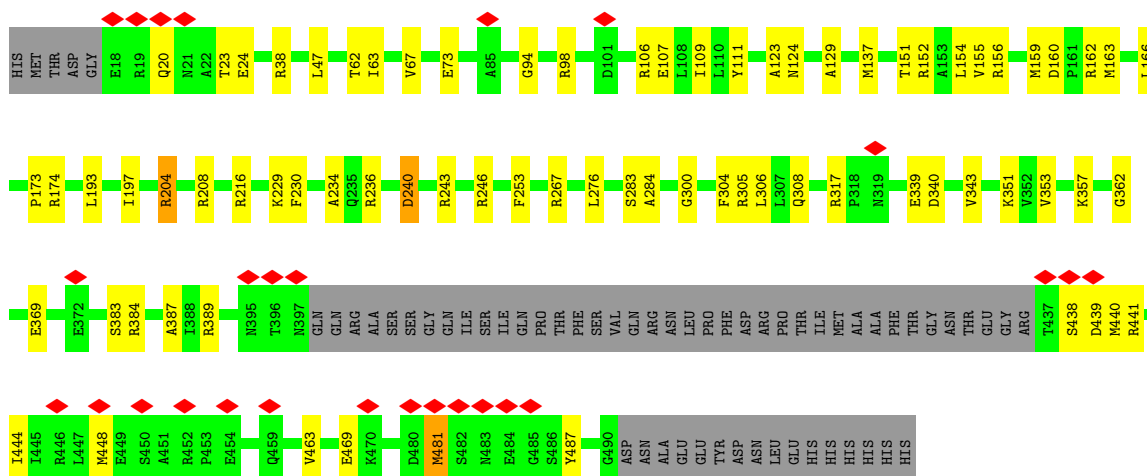

• Molecule 1: Nucleoprotein

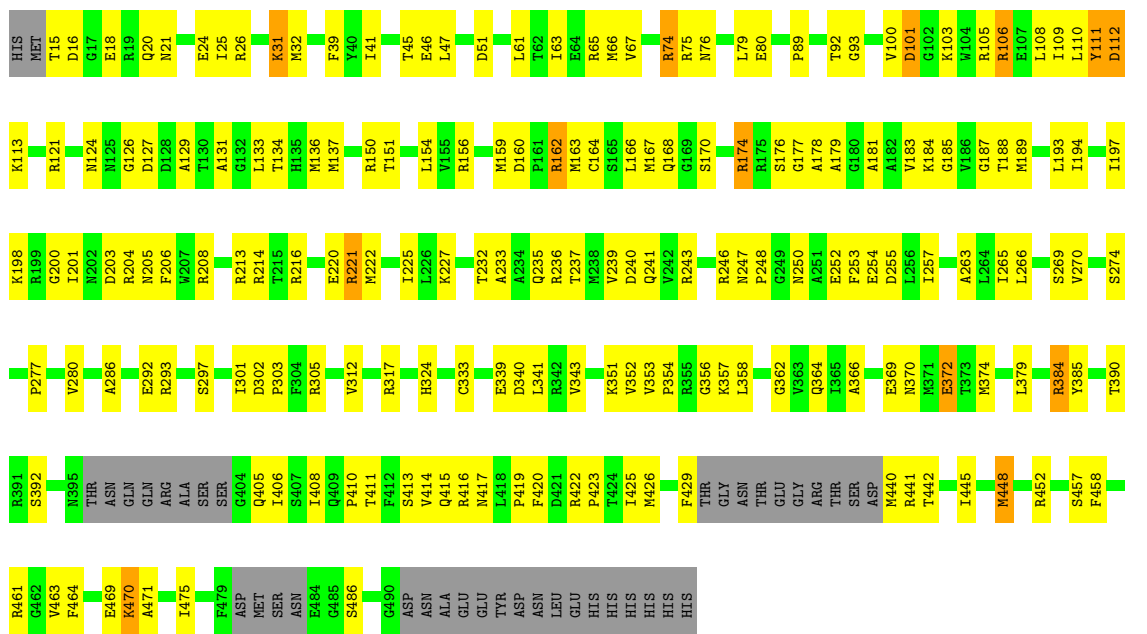

• Molecule 1: Nucleoprotein



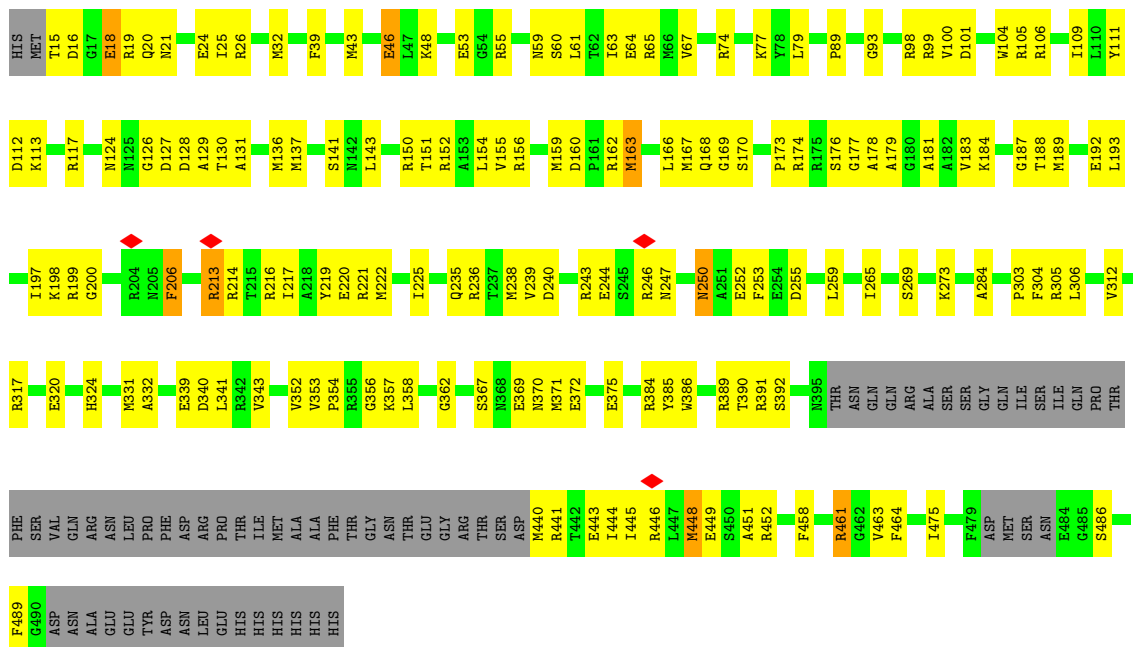

- Molecule 1: Nucleoprotein

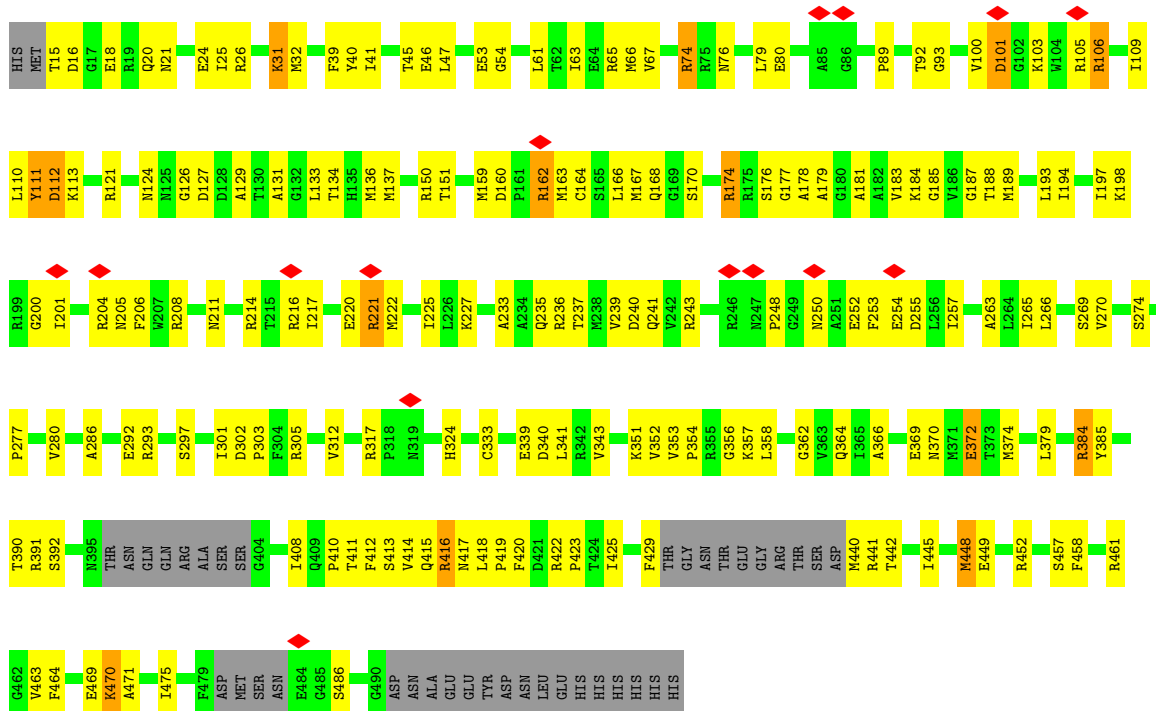

- Molecule 2: RNA (5'-P(UC)9-FAM3')



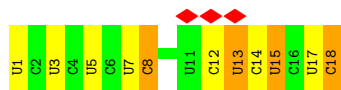

● Molecule 2: RNA (5'-P(UC)9-FAM3')



● Molecule 2: RNA (5'-P(UC)9-FAM3')

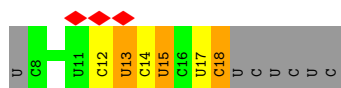
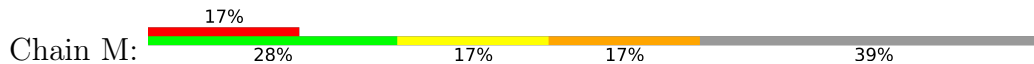

● Molecule 2: RNA (5'-P(UC)9-FAM3')

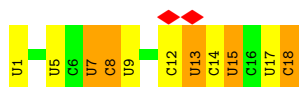

● Molecule 2: RNA (5'-P(UC)9-FAM3')



● Molecule 2: RNA (5'-P(UC)9-FAM3')

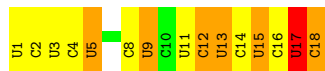
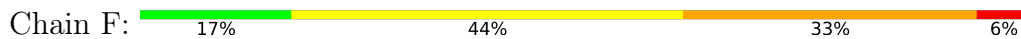

● Molecule 2: RNA (5'-P(UC)9-FAM3')

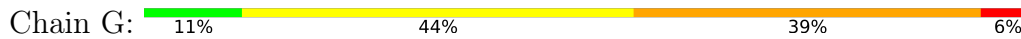

● Molecule 2: RNA (5'-P(UC)9-FAM3')



## 4 Experimental information

Property	Value	Source
EM reconstruction method	HELICAL	Depositor
Imposed symmetry	HELICAL, twist=56.13°, rise=27.3 Å, axial sym=C1	Depositor
Number of segments used	343311	Depositor
Resolution determination method	FSC 0.143 CUT-OFF	Depositor
CTF correction method	PHASE FLIPPING AND AMPLITUDE CORRECTION	Depositor
Microscope	TFS GLACIOS	Depositor
Voltage (kV)	200	Depositor
Electron dose ( $e^-/\text{Å}^2$ )	53	Depositor
Minimum defocus (nm)	500	Depositor
Maximum defocus (nm)	2000	Depositor
Magnification	36000	Depositor
Image detector	GATAN K2 SUMMIT (4k x 4k)	Depositor
Maximum map value	0.952	Depositor
Minimum map value	-0.400	Depositor
Average map value	0.000	Depositor
Map value standard deviation	0.020	Depositor
Recommended contour level	0.153	Depositor
Map size (Å)	458.0, 458.0, 458.0	wwPDB
Map dimensions	400, 400, 400	wwPDB
Map angles (°)	90.0, 90.0, 90.0	wwPDB
Pixel spacing (Å)	1.145, 1.145, 1.145	Depositor

## 5 Model quality [i](#)

### 5.1 Standard geometry [i](#)

Bond lengths and bond angles in the following residue types are not validated in this section: A1IJK

The Z score for a bond length (or angle) is the number of standard deviations the observed value is removed from the expected value. A bond length (or angle) with  $|Z| > 5$  is considered an outlier worth inspection. RMSZ is the root-mean-square of all Z scores of the bond lengths (or angles).

Mol	Chain	Bond lengths		Bond angles	
		RMSZ	# Z  >5	RMSZ	# Z  >5
1	A	0.26	0/3457	0.53	0/4642
1	B	0.26	0/3668	0.53	0/4928
1	C	0.26	0/3668	0.53	0/4928
1	D	0.27	0/211	0.54	0/286
1	I	0.28	0/3505	0.54	0/4709
1	J	0.28	0/3729	0.54	0/5013
1	K	0.28	0/3729	0.54	0/5013
1	L	0.30	0/224	0.59	0/304
2	E	0.27	0/241	0.72	0/370
2	F	0.62	1/396 (0.3%)	0.89	2/608 (0.3%)
2	G	0.62	1/396 (0.3%)	0.89	2/608 (0.3%)
2	H	0.90	1/154 (0.6%)	0.69	0/234
2	M	0.29	0/241	0.92	2/370 (0.5%)
2	N	0.69	1/396 (0.3%)	1.00	2/608 (0.3%)
2	O	0.71	1/396 (0.3%)	0.99	1/608 (0.2%)
2	P	0.96	1/154 (0.6%)	0.96	0/234
All	All	0.33	6/24565 (0.0%)	0.59	9/33463 (0.0%)

All (6) bond length outliers are listed below:

Mol	Chain	Res	Type	Atoms	Z	Observed(Å)	Ideal(Å)
2	H	1	U	OP3-P	-10.84	1.48	1.61
2	P	1	U	OP3-P	-10.71	1.48	1.61
2	O	1	U	OP3-P	-10.71	1.48	1.61
2	N	1	U	OP3-P	-10.68	1.48	1.61
2	F	1	U	OP3-P	-10.68	1.48	1.61
2	G	1	U	OP3-P	-10.67	1.48	1.61

All (9) bond angle outliers are listed below:

Mol	Chain	Res	Type	Atoms	Z	Observed(°)	Ideal(°)
2	F	17	U	P-O3'-C3'	-10.45	107.16	119.70
2	G	17	U	P-O3'-C3'	-10.42	107.19	119.70
2	F	17	U	OP1-P-O3'	7.20	121.03	105.20
2	G	17	U	OP1-P-O3'	7.18	121.00	105.20
2	O	13	U	C2-N1-C1'	5.84	124.71	117.70
2	M	13	U	C2-N1-C1'	5.82	124.69	117.70
2	N	13	U	C2-N1-C1'	5.80	124.67	117.70
2	N	13	U	N1-C2-O2	5.07	126.35	122.80
2	M	13	U	N1-C2-O2	5.04	126.33	122.80

There are no chirality outliers.

There are no planarity outliers.

## 5.2 Too-close contacts [i](#)

In the following table, the Non-H and H(model) columns list the number of non-hydrogen atoms and hydrogen atoms in the chain respectively. The H(added) column lists the number of hydrogen atoms added and optimized by MolProbity. The Clashes column lists the number of clashes within the asymmetric unit, whereas Symm-Clashes lists symmetry-related clashes.

Mol	Chain	Non-H	H(model)	H(added)	Clashes	Symm-Clashes
1	A	3400	0	3386	178	0
1	B	3606	0	3592	212	0
1	C	3606	0	3592	199	0
1	D	206	0	206	20	0
1	I	3447	0	3426	71	0
1	J	3666	0	3644	93	0
1	K	3666	0	3644	72	0
1	L	219	0	218	9	0
2	E	220	0	116	9	0
2	F	361	0	189	23	0
2	G	361	0	189	27	0
2	H	141	10	74	7	0
2	M	220	0	116	2	0
2	N	361	0	189	6	0
2	O	361	0	189	5	0
2	P	141	0	74	1	0
3	E	36	0	0	1	0
3	F	36	0	0	2	0
3	G	36	0	0	8	0
3	M	36	0	0	0	0
3	N	36	0	0	0	0

*Continued on next page...*

*Continued from previous page...*

Mol	Chain	Non-H	H(model)	H(added)	Clashes	Symm-Clashes
3	O	36	0	0	0	0
All	All	24198	10	22844	753	0

The all-atom clashscore is defined as the number of clashes found per 1000 atoms (including hydrogen atoms). The all-atom clashscore for this structure is 16.

All (753) close contacts within the same asymmetric unit are listed below, sorted by their clash magnitude.

Atom-1	Atom-2	Interatomic distance (Å)	Clash overlap (Å)
1:I:204:ARG:HH21	1:C:127:ASP:CA	1.20	1.54
1:I:204:ARG:NH2	1:C:127:ASP:HA	1.09	1.39
1:J:438:SER:HB3	1:A:247:ASN:CB	1.77	1.15
3:G:601:A1IJK:C6	1:I:246:ARG:HH12	1.63	1.11
1:J:18:GLU:HG2	1:I:156:ARG:NH2	1.63	1.10
1:J:439:ASP:CB	1:A:246:ARG:HB3	1.82	1.10
1:J:204:ARG:NH2	1:B:127:ASP:HA	1.65	1.09
1:J:438:SER:HB3	1:A:247:ASN:HB2	1.32	1.08
1:I:208:ARG:NH2	1:C:126:GLY:O	1.86	1.07
1:J:204:ARG:HH21	1:B:127:ASP:CA	1.67	1.06
1:J:204:ARG:HH21	1:B:127:ASP:HA	0.90	1.04
1:K:204:ARG:HH21	1:A:127:ASP:HA	1.20	1.04
1:J:439:ASP:HB3	1:A:246:ARG:HB3	1.12	1.04
1:C:189:MET:HE3	1:C:225:ILE:HG13	1.43	0.99
2:F:18:C:H1'	1:B:74:ARG:HD3	1.43	0.99
1:B:189:MET:HE3	1:B:225:ILE:HG13	1.44	0.99
1:C:440:MET:HG3	1:C:441:ARG:H	1.27	0.98
1:J:18:GLU:CG	1:I:156:ARG:HH22	1.77	0.98
2:G:18:C:H1'	1:C:74:ARG:HD3	1.44	0.98
1:J:18:GLU:HG2	1:I:156:ARG:HH22	0.83	0.97
3:G:601:A1IJK:C6	1:I:246:ARG:NH1	2.28	0.97
1:B:440:MET:HG3	1:B:441:ARG:H	1.27	0.96
1:I:204:ARG:NH2	1:C:127:ASP:CA	1.93	0.96
1:K:204:ARG:NH2	1:A:127:ASP:HA	1.80	0.96
1:K:18:GLU:HG2	1:J:156:ARG:HH22	1.31	0.94
1:K:18:GLU:HG2	1:J:156:ARG:HH12	1.28	0.94
1:J:439:ASP:HB3	1:A:246:ARG:CB	1.97	0.94
1:B:340:ASP:HB3	1:B:343:VAL:HG12	1.50	0.92
1:C:340:ASP:HB3	1:C:343:VAL:HG12	1.50	0.91
1:K:18:GLU:HG2	1:J:156:ARG:NH1	1.85	0.89
1:K:18:GLU:HG2	1:J:156:ARG:NH2	1.87	0.88
1:B:425:ILE:HD13	1:A:265:ILE:HD11	1.56	0.87

*Continued on next page...*



*Continued from previous page...*

Atom-1	Atom-2	Interatomic distance (Å)	Clash overlap (Å)
1:J:438:SER:CB	1:A:247:ASN:CB	2.53	0.87
2:G:1:U:N3	1:B:110:LEU:HD21	1.90	0.86
3:G:601:A1IJK:O26	1:I:216:ARG:HG2	1.76	0.85
1:B:79:LEU:HB3	1:B:89:PRO:HB3	1.59	0.85
1:C:79:LEU:HB3	1:C:89:PRO:HB3	1.59	0.85
1:I:204:ARG:NH2	1:C:127:ASP:CB	2.39	0.85
1:A:100:VAL:HB	1:A:105:ARG:NH2	1.92	0.84
1:A:167:MET:HE2	1:A:187:GLY:HA3	1.58	0.83
1:A:384:ARG:HG3	1:A:384:ARG:HH11	1.44	0.83
1:K:18:GLU:CG	1:J:156:ARG:HH22	1.92	0.82
1:A:79:LEU:HB3	1:A:89:PRO:HB3	1.62	0.81
1:J:438:SER:HB2	1:A:247:ASN:HD22	1.46	0.81
1:A:340:ASP:HB3	1:A:343:VAL:HG12	1.61	0.81
1:A:324:HIS:HB3	1:A:358:LEU:HD22	1.63	0.80
1:B:20:GLN:O	1:B:24:GLU:HG2	1.82	0.80
1:A:163:MET:HB2	1:A:166:LEU:HD12	1.61	0.80
1:K:18:GLU:HA	1:J:156:ARG:NH2	1.97	0.79
1:A:440:MET:HG3	1:A:441:ARG:H	1.47	0.79
1:B:340:ASP:HB2	1:C:408:ILE:HD11	1.65	0.79
1:B:408:ILE:HD11	1:A:340:ASP:HB2	1.65	0.79
1:D:408:ILE:HD11	1:C:340:ASP:HB2	1.65	0.79
1:C:20:GLN:O	1:C:24:GLU:HG2	1.82	0.79
1:A:181:ALA:HA	1:A:184:LYS:HD2	1.64	0.78
1:A:189:MET:HE1	1:A:225:ILE:HD11	1.65	0.78
1:B:440:MET:HG3	1:B:441:ARG:N	1.99	0.78
2:G:18:C:H1'	1:C:74:ARG:CD	2.14	0.77
2:F:18:C:H1'	1:B:74:ARG:CD	2.14	0.77
1:B:92:THR:HG23	1:B:113:LYS:HG2	1.66	0.77
1:A:15:THR:HA	1:A:18:GLU:HG3	1.65	0.77
1:K:18:GLU:HG2	1:J:156:ARG:CZ	2.14	0.77
1:C:92:THR:HG23	1:C:113:LYS:HG2	1.66	0.76
1:C:100:VAL:HB	1:C:105:ARG:HH11	1.50	0.76
1:I:208:ARG:CZ	1:C:121:ARG:HD3	2.14	0.76
1:B:100:VAL:HB	1:B:105:ARG:HH11	1.50	0.76
1:B:156:ARG:NH1	1:C:391:ARG:HH12	1.83	0.76
1:D:411:THR:HG22	1:C:339:GLU:HB2	1.67	0.76
1:B:339:GLU:HB2	1:C:411:THR:HG22	1.67	0.76
1:C:440:MET:HG3	1:C:441:ARG:N	1.99	0.76
1:K:18:GLU:CG	1:J:156:ARG:HH12	1.99	0.75
1:B:227:LYS:HB2	1:B:239:VAL:HG11	1.69	0.75
1:C:227:LYS:HB2	1:C:239:VAL:HG11	1.68	0.75

*Continued on next page...*

*Continued from previous page...*

Atom-1	Atom-2	Interatomic distance (Å)	Clash overlap (Å)
1:D:410:PRO:HA	1:C:339:GLU:OE1	1.88	0.74
1:J:438:SER:CB	1:A:247:ASN:ND2	2.50	0.74
1:K:208:ARG:NH2	1:A:126:GLY:O	2.17	0.74
1:I:439:ASP:HB3	1:B:246:ARG:HB3	1.70	0.74
1:B:339:GLU:OE1	1:C:410:PRO:HA	1.88	0.74
1:C:181:ALA:HA	1:C:184:LYS:HD2	1.69	0.74
1:J:438:SER:HB3	1:A:247:ASN:CG	2.09	0.73
1:A:240:ASP:OD1	1:A:243:ARG:NH2	2.20	0.73
1:B:181:ALA:HA	1:B:184:LYS:HD2	1.69	0.73
1:B:265:ILE:HD11	1:C:425:ILE:HD12	1.70	0.73
1:D:425:ILE:HD12	1:C:265:ILE:HD11	1.70	0.73
1:A:137:MET:HE1	1:A:176:SER:HB3	1.69	0.73
1:J:208:ARG:NH2	1:B:126:GLY:O	2.12	0.72
1:B:137:MET:CE	1:B:176:SER:HB3	2.18	0.72
1:K:340:ASP:HB3	1:K:343:VAL:HG12	1.72	0.72
1:B:193:LEU:HD21	1:B:222:MET:HG3	1.71	0.72
1:C:137:MET:CE	1:C:176:SER:HB3	2.18	0.72
2:N:7:U:H5'	1:I:152:ARG:HH21	1.55	0.72
1:I:340:ASP:HB3	1:I:343:VAL:HG12	1.72	0.72
1:J:438:SER:CB	1:A:247:ASN:HD22	2.02	0.71
1:C:193:LEU:HD21	1:C:222:MET:HG3	1.70	0.71
1:J:340:ASP:HB3	1:J:343:VAL:HG12	1.72	0.71
1:B:248:PRO:HA	1:B:252:GLU:OE2	1.90	0.71
1:C:384:ARG:NH2	1:C:385:TYR:OH	2.24	0.71
1:A:93:GLY:HA3	1:A:109:ILE:O	1.92	0.70
1:I:204:ARG:NE	1:C:126:GLY:O	2.23	0.70
2:H:2:C:H2'	2:H:3:U:C6	2.27	0.70
1:J:438:SER:CB	1:A:247:ASN:HB2	2.17	0.70
1:B:384:ARG:NH2	1:B:385:TYR:OH	2.24	0.70
1:A:43:MET:HE2	1:A:63:ILE:HG23	1.74	0.69
1:K:18:GLU:CB	1:J:156:ARG:HH22	2.04	0.69
1:C:248:PRO:HA	1:C:252:GLU:OE2	1.90	0.69
1:C:440:MET:CG	1:C:441:ARG:H	2.01	0.69
1:A:375:GLU:N	1:A:375:GLU:OE1	2.25	0.69
1:C:41:ILE:HD11	1:C:286:ALA:HB2	1.75	0.69
1:B:324:HIS:HB3	1:B:358:LEU:HD22	1.75	0.68
1:A:19:ARG:HG3	1:A:20:GLN:N	2.08	0.68
1:C:324:HIS:HB3	1:C:358:LEU:HD22	1.75	0.68
1:A:385:TYR:HB3	1:A:463:VAL:CG1	2.24	0.68
1:B:41:ILE:HD11	1:B:286:ALA:HB2	1.75	0.67
1:A:213:ARG:HB2	1:A:213:ARG:CZ	2.23	0.67

*Continued on next page...*

*Continued from previous page...*

Atom-1	Atom-2	Interatomic distance (Å)	Clash overlap (Å)
2:M:18:C:OP2	1:I:174:ARG:NH1	2.28	0.67
1:I:137:MET:HE3	1:I:173:PRO:HG2	1.76	0.66
2:N:18:C:OP2	1:J:174:ARG:NH1	2.28	0.66
1:A:317:ARG:NH2	1:A:362:GLY:O	2.28	0.66
1:C:216:ARG:O	1:C:220:GLU:HG2	1.96	0.66
1:B:216:ARG:O	1:B:220:GLU:HG2	1.96	0.66
2:F:16:C:H1'	1:B:174:ARG:HD2	1.77	0.66
1:B:440:MET:CG	1:B:441:ARG:H	2.01	0.66
1:C:317:ARG:NH2	1:C:362:GLY:O	2.29	0.66
1:B:408:ILE:CD1	1:A:340:ASP:HB2	2.26	0.66
1:C:92:THR:HG23	1:C:113:LYS:CG	2.25	0.66
1:C:93:GLY:HA3	1:C:109:ILE:O	1.96	0.66
1:B:92:THR:HG23	1:B:113:LYS:CG	2.25	0.66
1:I:444:ILE:O	1:I:448:MET:HG3	1.96	0.66
1:B:317:ARG:NH2	1:B:362:GLY:O	2.29	0.66
1:A:160:ASP:OD1	1:A:162:ARG:HG3	1.96	0.66
1:A:220:GLU:OE2	1:A:243:ARG:HD2	1.96	0.66
1:J:444:ILE:O	1:J:448:MET:HG3	1.96	0.65
1:A:339:GLU:HG3	1:A:340:ASP:N	2.12	0.65
2:O:18:C:OP2	1:K:174:ARG:NH1	2.28	0.65
2:G:16:C:H1'	1:C:174:ARG:HD2	1.77	0.65
2:H:1:U:N3	1:C:110:LEU:HD21	2.11	0.65
1:A:269:SER:HB2	1:A:391:ARG:O	1.97	0.65
1:B:93:GLY:HA3	1:B:109:ILE:O	1.96	0.65
1:K:18:GLU:HA	1:J:156:ARG:HH22	1.62	0.65
1:C:353:VAL:HG12	1:C:357:LYS:HB2	1.78	0.65
1:B:15:THR:HG22	1:B:16:ASP:H	1.62	0.64
1:B:156:ARG:HH12	1:C:391:ARG:HH12	1.43	0.64
1:C:441:ARG:O	1:C:445:ILE:HG13	1.97	0.64
1:B:166:LEU:HB3	1:B:187:GLY:H	1.62	0.64
1:A:214:ARG:O	1:A:217:ILE:HG13	1.97	0.64
1:C:46:GLU:HG2	1:C:111:TYR:OH	1.97	0.64
1:K:137:MET:HE3	1:K:173:PRO:HG2	1.77	0.64
1:B:220:GLU:OE2	1:B:243:ARG:HG3	1.98	0.64
1:B:353:VAL:HG12	1:B:357:LYS:HB2	1.78	0.64
1:C:15:THR:HG22	1:C:16:ASP:H	1.62	0.64
1:K:444:ILE:O	1:K:448:MET:HG3	1.96	0.64
1:B:441:ARG:O	1:B:445:ILE:HG13	1.97	0.64
1:B:340:ASP:CB	1:C:408:ILE:HD11	2.28	0.64
1:C:166:LEU:HB3	1:C:187:GLY:H	1.62	0.64
1:C:216:ARG:O	1:C:216:ARG:HD2	1.97	0.64

*Continued on next page...*

*Continued from previous page...*

Atom-1	Atom-2	Interatomic distance (Å)	Clash overlap (Å)
1:A:240:ASP:O	1:A:244:GLU:HG2	1.98	0.63
2:O:15:U:OP1	1:K:174:ARG:NH2	2.31	0.63
2:N:15:U:OP1	1:J:174:ARG:NH2	2.31	0.63
1:B:216:ARG:O	1:B:216:ARG:HD2	1.97	0.63
2:N:8:C:H1'	1:J:391:ARG:HB3	1.81	0.63
1:B:46:GLU:HG2	1:B:111:TYR:OH	1.97	0.63
1:B:458:PHE:HB2	1:C:414:VAL:O	1.99	0.63
1:C:220:GLU:OE2	1:C:243:ARG:HG3	1.98	0.63
1:D:408:ILE:HD11	1:C:340:ASP:CB	2.28	0.63
1:D:414:VAL:O	1:C:458:PHE:HB2	1.99	0.63
1:B:250:ASN:O	1:B:254:GLU:HG2	1.98	0.63
1:A:384:ARG:HG3	1:A:384:ARG:NH1	2.14	0.62
2:M:15:U:OP1	1:I:174:ARG:NH2	2.31	0.62
1:A:193:LEU:HD21	1:A:222:MET:HG3	1.80	0.62
1:A:340:ASP:OD1	1:A:486:SER:HB2	1.99	0.62
1:D:416:ARG:HD3	1:D:418:LEU:HD23	1.82	0.62
1:C:92:THR:CG2	1:C:113:LYS:HE3	2.29	0.62
2:E:15:U:O4'	1:A:130:THR:HG21	1.99	0.62
1:C:100:VAL:HB	1:C:105:ARG:NH1	2.14	0.62
1:A:61:LEU:O	1:A:65:ARG:HG3	1.99	0.62
1:B:92:THR:CG2	1:B:113:LYS:HE3	2.29	0.62
1:A:127:ASP:OD1	1:A:128:ASP:N	2.32	0.62
1:C:250:ASN:O	1:C:254:GLU:HG2	1.98	0.62
1:A:440:MET:HG3	1:A:441:ARG:N	2.15	0.61
1:I:204:ARG:HH22	1:C:127:ASP:HA	1.51	0.61
1:B:416:ARG:HG2	1:B:416:ARG:HH11	1.64	0.61
1:D:408:ILE:HD11	1:C:340:ASP:CA	2.30	0.61
1:J:230:PHE:O	1:J:236:ARG:NH1	2.34	0.61
1:B:340:ASP:HB2	1:C:408:ILE:CD1	2.29	0.61
1:B:340:ASP:CA	1:C:408:ILE:HD11	2.30	0.61
1:I:230:PHE:O	1:I:236:ARG:NH1	2.34	0.61
1:B:189:MET:CE	1:B:225:ILE:HG13	2.27	0.61
1:A:21:ASN:O	1:A:25:ILE:HG12	2.00	0.61
1:D:408:ILE:CD1	1:C:340:ASP:HB2	2.29	0.61
1:A:53:GLU:OE1	1:A:98:ARG:HG3	2.01	0.61
1:B:100:VAL:HB	1:B:105:ARG:NH1	2.14	0.61
1:A:20:GLN:OE1	1:A:20:GLN:HA	2.01	0.61
1:B:415:GLN:HG3	1:B:415:GLN:O	2.00	0.60
1:K:230:PHE:O	1:K:236:ARG:NH1	2.34	0.60
1:A:63:ILE:O	1:A:67:VAL:HG23	2.01	0.60
1:C:416:ARG:HD3	1:C:418:LEU:HD23	1.82	0.60

*Continued on next page...*

*Continued from previous page...*

Atom-1	Atom-2	Interatomic distance (Å)	Clash overlap (Å)
2:E:18:C:H1'	1:A:74:ARG:HG3	1.83	0.60
1:J:38:ARG:NH1	1:J:123:ALA:O	2.27	0.60
1:J:204:ARG:HH21	1:B:127:ASP:CB	2.14	0.60
1:A:441:ARG:O	1:A:445:ILE:HG13	2.01	0.60
1:C:205:ASN:HA	1:C:208:ARG:NH2	2.17	0.60
1:C:194:ILE:O	1:C:198:LYS:HG2	2.02	0.60
1:B:194:ILE:O	1:B:198:LYS:HG2	2.02	0.59
1:A:221:ARG:HB3	1:A:221:ARG:NH1	2.16	0.59
1:B:205:ASN:HA	1:B:208:ARG:NH2	2.17	0.59
1:K:305:ARG:NH1	1:K:469:GLU:OE1	2.36	0.59
1:J:439:ASP:OD2	1:A:246:ARG:NH2	2.33	0.59
1:J:305:ARG:NH1	1:J:469:GLU:OE1	2.36	0.59
1:B:92:THR:CG2	1:B:113:LYS:HG2	2.32	0.59
2:F:12:C:H42	2:F:14:C:H41	1.50	0.59
1:K:18:GLU:CA	1:J:156:ARG:HH22	2.16	0.59
2:G:12:C:H42	2:G:14:C:H41	1.50	0.59
1:A:106:ARG:NH1	1:A:367:SER:HA	2.18	0.59
1:K:63:ILE:O	1:K:67:VAL:HG23	2.03	0.58
1:K:204:ARG:HH21	1:A:127:ASP:CA	2.04	0.58
1:B:167:MET:HA	1:B:167:MET:CE	2.33	0.58
1:B:413:SER:OG	1:A:390:THR:HG22	2.03	0.58
1:C:92:THR:CG2	1:C:113:LYS:HG2	2.32	0.58
1:I:305:ARG:NH1	1:I:469:GLU:OE1	2.36	0.58
1:C:167:MET:HA	1:C:167:MET:CE	2.34	0.58
2:G:2:C:H2'	2:G:3:U:C6	2.39	0.58
1:J:63:ILE:O	1:J:67:VAL:HG23	2.03	0.58
1:A:137:MET:CE	1:A:176:SER:HB3	2.33	0.58
1:B:198:LYS:HB3	1:B:198:LYS:HZ3	1.67	0.58
1:C:66:MET:SD	1:C:93:GLY:HA2	2.44	0.58
2:F:2:C:H2'	2:F:3:U:C6	2.39	0.58
1:I:63:ILE:O	1:I:67:VAL:HG23	2.03	0.58
1:B:317:ARG:NH1	1:B:369:GLU:OE2	2.36	0.58
1:C:137:MET:HE1	1:C:176:SER:HB3	1.84	0.58
1:C:317:ARG:NH1	1:C:369:GLU:OE2	2.36	0.58
1:A:317:ARG:NH1	1:A:369:GLU:OE2	2.37	0.57
1:C:340:ASP:OD1	1:C:486:SER:HB2	2.05	0.57
1:B:166:LEU:HD11	1:B:263:ALA:HB3	1.86	0.57
1:J:204:ARG:NH2	1:B:127:ASP:CB	2.67	0.57
1:A:341:LEU:HD12	1:A:352:VAL:O	2.05	0.57
1:B:66:MET:SD	1:B:93:GLY:HA2	2.44	0.57
1:A:372:GLU:O	1:A:372:GLU:HG3	2.04	0.57

*Continued on next page...*

*Continued from previous page...*

Atom-1	Atom-2	Interatomic distance (Å)	Clash overlap (Å)
1:C:166:LEU:HD11	1:C:263:ALA:HB3	1.86	0.57
1:B:208:ARG:HH11	1:B:208:ARG:HB2	1.69	0.57
1:B:425:ILE:CD1	1:A:265:ILE:HD11	2.33	0.57
1:A:43:MET:CE	1:A:63:ILE:HG23	2.33	0.57
3:G:601:A1IJK:O26	1:I:216:ARG:CG	2.51	0.56
1:I:38:ARG:NH1	1:I:123:ALA:O	2.27	0.56
2:H:5:U:O4	1:C:356:GLY:HA2	2.05	0.56
1:B:237:THR:O	1:B:241:GLN:HG3	2.06	0.56
1:B:340:ASP:OD1	1:B:486:SER:HB2	2.05	0.56
1:C:208:ARG:HH11	1:C:208:ARG:HB2	1.69	0.56
1:I:204:ARG:HH21	1:C:127:ASP:HA	0.48	0.56
1:B:372:GLU:HG3	1:B:372:GLU:O	2.06	0.56
1:J:204:ARG:NH2	1:B:127:ASP:CA	2.46	0.56
1:A:216:ARG:HD2	1:A:216:ARG:O	2.06	0.56
1:C:133:LEU:HA	1:C:136:MET:HE2	1.88	0.56
1:C:159:MET:HG2	1:C:257:ILE:CD1	2.36	0.56
1:A:197:ILE:HD11	1:A:219:TYR:HE2	1.71	0.56
2:G:1:U:C2	1:B:110:LEU:HD21	2.41	0.56
1:B:137:MET:HE1	1:B:176:SER:HB3	1.86	0.56
1:C:372:GLU:O	1:C:372:GLU:HG3	2.06	0.56
1:C:21:ASN:O	1:C:25:ILE:HG12	2.06	0.55
1:C:227:LYS:CB	1:C:239:VAL:HG11	2.36	0.55
1:J:438:SER:CB	1:A:247:ASN:HB3	2.35	0.55
1:B:340:ASP:HB3	1:B:343:VAL:CG1	2.29	0.55
1:C:340:ASP:HB3	1:C:343:VAL:CG1	2.29	0.55
1:B:159:MET:HG2	1:B:257:ILE:CD1	2.36	0.55
1:B:236:ARG:O	1:B:239:VAL:HG12	2.06	0.55
1:C:65:ARG:HD2	1:C:364:GLN:HE22	1.71	0.55
2:G:1:U:C4	1:B:110:LEU:HD21	2.41	0.55
1:B:208:ARG:HB2	1:B:208:ARG:NH1	2.21	0.55
1:A:250:ASN:C	1:A:250:ASN:HD22	2.08	0.55
1:C:351:LYS:NZ	1:C:351:LYS:HB3	2.22	0.55
1:B:351:LYS:HB3	1:B:351:LYS:HZ1	1.72	0.55
1:B:408:ILE:HD11	1:A:340:ASP:N	2.20	0.55
1:A:104:TRP:C	1:A:371:MET:HE3	2.26	0.55
1:K:38:ARG:NH1	1:K:123:ALA:O	2.27	0.55
1:K:304:PHE:HE2	1:K:389:ARG:HH12	1.54	0.55
1:B:227:LYS:CB	1:B:239:VAL:HG11	2.36	0.55
1:B:426:MET:HE1	1:A:449:GLU:HG2	1.88	0.55
1:C:168:GLN:O	1:C:188:THR:HG21	2.07	0.55
1:J:304:PHE:HE2	1:J:389:ARG:HH12	1.54	0.55

*Continued on next page...*

*Continued from previous page...*

Atom-1	Atom-2	Interatomic distance (Å)	Clash overlap (Å)
1:C:237:THR:O	1:C:241:GLN:HG3	2.06	0.55
1:B:65:ARG:HD2	1:B:364:GLN:HE22	1.71	0.55
1:B:339:GLU:HG3	1:B:340:ASP:N	2.22	0.55
1:I:304:PHE:HE2	1:I:389:ARG:HH12	1.54	0.55
1:B:408:ILE:HD11	1:A:340:ASP:CB	2.36	0.55
1:B:351:LYS:HB3	1:B:351:LYS:NZ	2.22	0.55
1:B:406:ILE:HG21	1:A:162:ARG:HE	1.72	0.55
1:B:417:ASN:O	1:B:419:PRO:HD3	2.06	0.55
2:H:1:U:C2	1:C:110:LEU:HD21	2.42	0.54
1:B:21:ASN:O	1:B:25:ILE:HG12	2.06	0.54
1:B:168:GLN:O	1:B:188:THR:HG21	2.07	0.54
1:C:160:ASP:O	1:C:163:MET:HG2	2.07	0.54
1:C:208:ARG:HB2	1:C:208:ARG:NH1	2.21	0.54
1:J:137:MET:HE3	1:J:173:PRO:HG2	1.88	0.54
1:K:240:ASP:OD1	1:K:243:ARG:NH2	2.41	0.54
1:D:413:SER:OG	1:C:390:THR:HG22	2.07	0.54
1:C:227:LYS:HB2	1:C:239:VAL:CG1	2.38	0.54
1:C:174:ARG:O	1:C:174:ARG:HG2	2.06	0.54
1:C:236:ARG:O	1:C:239:VAL:HG12	2.06	0.54
2:G:18:C:C1'	1:C:74:ARG:HD3	2.28	0.54
1:K:193:LEU:O	1:K:197:ILE:HG12	2.08	0.54
1:J:20:GLN:O	1:J:24:GLU:HG2	2.08	0.54
1:B:160:ASP:O	1:B:163:MET:HG2	2.07	0.54
1:A:370:ASN:OD1	1:A:370:ASN:O	2.26	0.54
1:K:20:GLN:O	1:K:24:GLU:HG2	2.08	0.54
1:B:174:ARG:O	1:B:174:ARG:HG2	2.06	0.54
1:K:47:LEU:O	1:K:98:ARG:NH2	2.41	0.54
1:I:240:ASP:OD1	1:I:243:ARG:NH2	2.41	0.54
1:A:137:MET:HE3	1:A:173:PRO:HG2	1.89	0.54
1:C:339:GLU:HG3	1:C:340:ASP:N	2.22	0.54
1:B:197:ILE:O	1:B:201:ILE:HG12	2.08	0.54
1:B:420:PHE:CD2	1:A:265:ILE:HD12	2.43	0.54
1:C:15:THR:O	1:C:16:ASP:HB3	2.08	0.54
1:C:370:ASN:OD1	1:C:372:GLU:HB3	2.08	0.54
1:I:20:GLN:O	1:I:24:GLU:HG2	2.08	0.53
1:K:416:ARG:NH1	1:J:339:GLU:OE2	2.41	0.53
1:B:61:LEU:O	1:B:65:ARG:HG3	2.08	0.53
1:B:227:LYS:HB2	1:B:239:VAL:CG1	2.38	0.53
1:C:197:ILE:O	1:C:201:ILE:HG12	2.08	0.53
1:J:439:ASP:HB2	1:A:246:ARG:HB3	1.84	0.53
1:B:15:THR:O	1:B:16:ASP:HB3	2.08	0.53

*Continued on next page...*

*Continued from previous page...*

Atom-1	Atom-2	Interatomic distance (Å)	Clash overlap (Å)
1:B:133:LEU:HA	1:B:136:MET:HE2	1.89	0.53
1:B:390:THR:HG22	1:C:413:SER:OG	2.07	0.53
1:A:79:LEU:HB3	1:A:89:PRO:CB	2.36	0.53
1:J:416:ARG:NH1	1:I:339:GLU:OE2	2.41	0.53
1:I:193:LEU:O	1:I:197:ILE:HG12	2.08	0.53
1:B:317:ARG:HA	1:B:374:MET:HE3	1.89	0.53
1:C:124:ASN:HD22	1:C:129:ALA:HB3	1.73	0.53
1:C:198:LYS:HZ3	1:C:198:LYS:HB3	1.72	0.53
2:H:3:U:H2'	2:H:4:C:C6	2.43	0.53
1:J:240:ASP:OD1	1:J:243:ARG:NH2	2.41	0.53
1:I:204:ARG:HH21	1:C:127:ASP:CB	2.00	0.53
1:A:15:THR:HG22	1:A:16:ASP:H	1.72	0.53
1:C:61:LEU:O	1:C:65:ARG:HG3	2.08	0.53
1:L:416:ARG:NH1	1:K:339:GLU:OE2	2.41	0.53
1:C:193:LEU:HD23	1:C:222:MET:SD	2.49	0.53
1:I:384:ARG:HG2	1:I:384:ARG:HH11	1.74	0.53
1:C:189:MET:CE	1:C:225:ILE:HG13	2.27	0.53
1:B:193:LEU:HD23	1:B:222:MET:SD	2.49	0.53
1:A:168:GLN:O	1:A:188:THR:HG21	2.09	0.53
2:E:9:U:N3	1:A:461:ARG:HG3	2.23	0.53
1:D:425:ILE:CD1	1:C:265:ILE:HD11	2.38	0.53
1:B:340:ASP:N	1:C:408:ILE:HD11	2.24	0.53
1:K:406:ILE:HD11	1:J:162:ARG:HD2	1.91	0.52
1:A:221:ARG:CB	1:A:221:ARG:HH11	2.22	0.52
1:L:411:THR:N	1:K:339:GLU:OE1	2.40	0.52
1:B:124:ASN:HD22	1:B:129:ALA:HB3	1.73	0.52
1:B:265:ILE:HD11	1:C:425:ILE:CD1	2.38	0.52
2:F:18:C:C1'	1:B:74:ARG:HD3	2.28	0.52
1:J:193:LEU:O	1:J:197:ILE:HG12	2.08	0.52
1:J:407:SER:OG	1:I:267:ARG:NH1	2.42	0.52
1:B:370:ASN:OD1	1:B:372:GLU:HB3	2.08	0.52
1:C:76:ASN:ND2	1:C:113:LYS:HE2	2.24	0.52
2:F:8:C:C5	1:B:392:SER:HB2	2.44	0.52
2:G:15:U:H3'	2:G:15:U:O2	2.09	0.52
1:J:384:ARG:HG2	1:J:384:ARG:HH11	1.74	0.52
2:G:8:C:C5	1:C:392:SER:HB2	2.44	0.52
1:L:406:ILE:HD11	1:K:162:ARG:HD2	1.91	0.52
1:L:407:SER:OG	1:K:267:ARG:NH1	2.42	0.52
1:D:408:ILE:HD11	1:C:340:ASP:N	2.24	0.52
1:B:76:ASN:ND2	1:B:113:LYS:HE2	2.25	0.52
1:B:167:MET:HA	1:B:167:MET:HE2	1.92	0.52

*Continued on next page...*



*Continued from previous page...*

Atom-1	Atom-2	Interatomic distance (Å)	Clash overlap (Å)
2:E:18:C:H1'	1:A:74:ARG:CG	2.40	0.52
1:D:422:ARG:HB3	1:D:423:PRO:HD3	1.91	0.52
1:K:407:SER:OG	1:J:267:ARG:NH1	2.42	0.52
1:I:47:LEU:O	1:I:98:ARG:NH2	2.41	0.52
1:A:124:ASN:ND2	1:A:129:ALA:HB3	2.24	0.52
2:F:15:U:H3'	2:F:15:U:O2	2.09	0.52
2:F:18:C:H1'	1:B:74:ARG:CG	2.40	0.52
2:F:5:U:O4	1:A:356:GLY:HA2	2.09	0.52
1:B:293:ARG:HG3	1:B:293:ARG:HH11	1.75	0.52
1:J:406:ILE:HD11	1:I:162:ARG:HD2	1.91	0.51
1:A:213:ARG:O	1:A:217:ILE:HG23	2.10	0.51
1:K:384:ARG:HH11	1:K:384:ARG:HG2	1.74	0.51
2:F:9:U:N3	1:B:461:ARG:HG2	2.25	0.51
1:J:387:ALA:HB2	1:J:463:VAL:HG12	1.92	0.51
1:C:353:VAL:CG1	1:C:357:LYS:HB2	2.41	0.51
1:C:422:ARG:HB3	1:C:423:PRO:HD3	1.91	0.51
1:L:412:PHE:O	1:L:416:ARG:NH2	2.41	0.51
1:A:193:LEU:CD2	1:A:222:MET:HG3	2.41	0.51
1:A:221:ARG:NH1	1:A:221:ARG:CB	2.73	0.51
2:E:8:C:C5	1:A:392:SER:HB2	2.45	0.51
1:I:98:ARG:NH1	1:I:107:GLU:OE1	2.44	0.51
1:J:47:LEU:O	1:J:98:ARG:NH2	2.41	0.51
1:C:32:MET:CE	1:C:131:ALA:HB1	2.41	0.51
2:G:9:U:N3	1:C:461:ARG:HG2	2.25	0.51
1:K:98:ARG:NH1	1:K:107:GLU:OE1	2.44	0.51
1:A:39:PHE:CE2	1:A:67:VAL:HG21	2.46	0.51
1:A:15:THR:O	1:A:16:ASP:HB3	2.11	0.51
1:C:293:ARG:HG3	1:C:293:ARG:HH11	1.75	0.51
2:O:8:C:H1'	1:K:391:ARG:HB3	1.93	0.50
1:J:98:ARG:NH1	1:J:107:GLU:OE1	2.44	0.50
1:J:412:PHE:O	1:J:416:ARG:NH2	2.41	0.50
1:B:201:ILE:HD13	1:B:201:ILE:N	2.25	0.50
1:B:416:ARG:HG2	1:B:416:ARG:NH1	2.26	0.50
1:C:167:MET:HA	1:C:167:MET:HE2	1.94	0.50
2:G:18:C:H1'	1:C:74:ARG:CG	2.40	0.50
1:C:470:LYS:NZ	1:C:470:LYS:HB3	2.27	0.50
1:D:420:PHE:CD2	1:C:265:ILE:HD12	2.47	0.50
1:K:412:PHE:O	1:K:416:ARG:NH2	2.41	0.50
1:J:438:SER:HB3	1:A:247:ASN:ND2	2.23	0.50
1:I:387:ALA:HB2	1:I:463:VAL:HG12	1.92	0.50
1:C:106:ARG:O	1:C:106:ARG:HG2	2.11	0.50

*Continued on next page...*

*Continued from previous page...*

Atom-1	Atom-2	Interatomic distance (Å)	Clash overlap (Å)
1:C:201:ILE:N	1:C:201:ILE:HD13	2.25	0.50
1:C:317:ARG:HA	1:C:374:MET:HE3	1.92	0.50
1:D:411:THR:HG22	1:C:339:GLU:CB	2.40	0.50
1:A:113:LYS:O	1:A:117:ARG:HG3	2.11	0.50
1:C:63:ILE:O	1:C:67:VAL:HG23	2.12	0.50
1:A:154:LEU:HD21	1:A:167:MET:HE3	1.94	0.50
1:A:324:HIS:CB	1:A:358:LEU:HD22	2.36	0.50
1:A:463:VAL:O	1:A:475:ILE:HB	2.12	0.50
1:C:339:GLU:OE2	1:C:343:VAL:HG11	2.12	0.50
1:K:387:ALA:HB2	1:K:463:VAL:HG12	1.92	0.50
1:J:411:THR:N	1:I:339:GLU:OE1	2.40	0.50
1:I:154:LEU:HD23	1:I:159:MET:HE2	1.93	0.50
2:G:2:C:O2'	2:G:3:U:H5'	2.12	0.50
1:K:154:LEU:HD23	1:K:159:MET:HE2	1.93	0.50
1:B:32:MET:CE	1:B:131:ALA:HB1	2.41	0.50
1:B:106:ARG:O	1:B:106:ARG:HG2	2.11	0.50
1:B:265:ILE:HD12	1:C:420:PHE:CD2	2.47	0.50
1:B:470:LYS:NZ	1:B:470:LYS:HB3	2.27	0.50
2:G:6:C:H4'	1:B:151:THR:CG2	2.42	0.50
1:B:339:GLU:OE2	1:B:343:VAL:HG11	2.12	0.50
1:B:353:VAL:CG1	1:B:357:LYS:HB2	2.41	0.50
1:C:39:PHE:CE2	1:C:67:VAL:HG21	2.47	0.50
1:C:341:LEU:HD12	1:C:352:VAL:O	2.12	0.50
2:F:2:C:O2'	2:F:3:U:H5'	2.12	0.49
1:C:463:VAL:O	1:C:475:ILE:HB	2.12	0.49
1:B:415:GLN:O	1:B:415:GLN:CG	2.59	0.49
1:A:353:VAL:HG12	1:A:357:LYS:HB2	1.93	0.49
1:A:385:TYR:HB3	1:A:463:VAL:HG12	1.93	0.49
1:C:366:ALA:HB3	1:C:369:GLU:HG3	1.95	0.49
1:B:39:PHE:CE2	1:B:67:VAL:HG21	2.47	0.49
1:C:133:LEU:HD23	1:C:136:MET:HE1	1.95	0.49
1:B:63:ILE:O	1:B:67:VAL:HG23	2.12	0.49
1:B:341:LEU:HD12	1:B:352:VAL:O	2.12	0.49
1:A:213:ARG:HB2	1:A:213:ARG:NH1	2.27	0.49
1:B:339:GLU:CB	1:C:411:THR:HG22	2.40	0.49
1:C:177:GLY:O	1:C:179:ALA:N	2.45	0.49
2:E:12:C:H1'	2:E:13:U:O5'	2.12	0.49
1:J:154:LEU:HD23	1:J:159:MET:HE2	1.94	0.49
1:A:183:VAL:HG12	1:A:183:VAL:O	2.11	0.49
1:C:150:ARG:HD3	1:C:170:SER:OG	2.13	0.49
1:B:47:LEU:HD21	1:B:109:ILE:HG21	1.94	0.49

*Continued on next page...*

*Continued from previous page...*

Atom-1	Atom-2	Interatomic distance (Å)	Clash overlap (Å)
1:B:205:ASN:OD1	1:B:205:ASN:O	2.31	0.49
1:B:463:VAL:O	1:B:475:ILE:HB	2.12	0.49
1:A:440:MET:CG	1:A:441:ARG:H	2.17	0.49
1:B:366:ALA:HB3	1:B:369:GLU:HG3	1.94	0.48
1:B:414:VAL:O	1:A:458:PHE:HB2	2.13	0.48
1:B:470:LYS:HB3	1:B:470:LYS:HZ3	1.78	0.48
1:J:438:SER:HB2	1:A:247:ASN:ND2	2.18	0.48
1:B:177:GLY:O	1:B:179:ALA:N	2.45	0.48
1:C:205:ASN:OD1	1:C:205:ASN:O	2.31	0.48
1:B:150:ARG:HD3	1:B:170:SER:OG	2.13	0.48
1:C:235:GLN:HE22	1:C:266:LEU:HB2	1.78	0.48
2:F:11:U:N3	1:B:18:GLU:OE1	2.43	0.48
1:I:441:ARG:NH2	1:B:213:ARG:HH21	2.12	0.48
1:A:443:GLU:CD	1:A:446:ARG:HH21	2.17	0.48
1:C:47:LEU:HD21	1:C:109:ILE:HG21	1.94	0.48
1:K:308:GLN:NE2	1:K:383:SER:O	2.47	0.48
1:K:411:THR:N	1:J:339:GLU:OE1	2.40	0.48
1:D:417:ASN:O	1:D:419:PRO:HD3	2.14	0.48
1:B:235:GLN:HE22	1:B:266:LEU:HB2	1.78	0.48
1:B:312:VAL:HG12	1:B:379:LEU:HD12	1.95	0.48
2:G:11:U:N3	1:C:18:GLU:OE1	2.43	0.48
1:B:221:ARG:O	1:B:225:ILE:HG23	2.14	0.47
1:B:353:VAL:CG1	1:B:354:PRO:HD2	2.44	0.47
1:A:353:VAL:HG12	1:A:354:PRO:HD2	1.95	0.47
1:I:284:ALA:HB2	1:I:306:LEU:HD11	1.96	0.47
1:I:308:GLN:NE2	1:I:383:SER:O	2.47	0.47
1:B:189:MET:HE3	1:B:225:ILE:CG1	2.31	0.47
1:A:353:VAL:CG1	1:A:354:PRO:HD2	2.44	0.47
1:A:444:ILE:O	1:A:448:MET:HG2	2.15	0.47
1:C:221:ARG:O	1:C:225:ILE:HG23	2.14	0.47
2:G:3:U:O2'	2:G:4:C:H5'	2.14	0.47
2:H:6:C:H4'	1:C:151:THR:CG2	2.44	0.47
1:C:312:VAL:HG12	1:C:379:LEU:HD12	1.95	0.47
1:C:417:ASN:O	1:C:419:PRO:HD3	2.14	0.47
1:J:308:GLN:NE2	1:J:383:SER:O	2.47	0.47
1:A:177:GLY:O	1:A:179:ALA:N	2.47	0.47
1:A:189:MET:CE	1:A:225:ILE:HD11	2.40	0.47
1:A:303:PRO:HG2	1:A:389:ARG:NH2	2.29	0.47
2:F:9:U:O2'	1:A:152:ARG:NH1	2.48	0.47
1:J:216:ARG:NH2	1:J:243:ARG:O	2.47	0.47
1:B:208:ARG:NH1	1:B:208:ARG:CB	2.78	0.47

*Continued on next page...*

*Continued from previous page...*

Atom-1	Atom-2	Interatomic distance (Å)	Clash overlap (Å)
1:C:134:THR:HA	1:C:137:MET:HE2	1.97	0.47
2:H:6:C:H4'	1:C:151:THR:HG22	1.97	0.47
1:I:216:ARG:NH2	1:I:243:ARG:O	2.47	0.47
1:C:353:VAL:HG12	1:C:354:PRO:HD2	1.96	0.47
1:C:353:VAL:CG1	1:C:354:PRO:HD2	2.44	0.47
2:E:12:C:C4	1:A:25:ILE:HD12	2.50	0.47
3:E:601:A1IJK:C8	1:K:216:ARG:HG2	2.44	0.47
2:F:3:U:O2'	2:F:4:C:H5'	2.14	0.47
1:J:234:ALA:HA	1:J:440:MET:HE2	1.97	0.47
1:I:234:ALA:HA	1:I:440:MET:HE2	1.97	0.47
1:B:353:VAL:HG12	1:B:354:PRO:HD2	1.96	0.47
1:B:408:ILE:HD11	1:A:340:ASP:CA	2.45	0.47
1:B:429:PHE:HE2	1:A:448:MET:CE	2.27	0.47
1:C:208:ARG:NH1	1:C:208:ARG:CB	2.78	0.47
1:K:20:GLN:O	1:K:23:THR:HG22	2.15	0.47
1:B:133:LEU:HD23	1:B:136:MET:HE1	1.96	0.47
1:C:92:THR:HG21	1:C:113:LYS:HE3	1.97	0.47
1:J:284:ALA:HB2	1:J:306:LEU:HD11	1.96	0.47
1:A:221:ARG:O	1:A:225:ILE:HG23	2.15	0.47
2:G:5:U:O4	1:B:356:GLY:HA2	2.15	0.47
1:A:152:ARG:O	1:A:156:ARG:HB2	2.15	0.47
1:A:174:ARG:NH1	1:A:174:ARG:HB2	2.30	0.47
1:K:216:ARG:NH2	1:K:243:ARG:O	2.47	0.46
1:A:284:ALA:HB2	1:A:306:LEU:HD11	1.97	0.46
1:J:300:GLY:O	1:J:389:ARG:NH2	2.48	0.46
1:C:101:ASP:OD1	1:C:101:ASP:C	2.53	0.46
1:K:479:PHE:HA	1:K:481:MET:HE1	1.98	0.46
1:I:300:GLY:O	1:I:389:ARG:NH2	2.48	0.46
1:A:188:THR:O	1:A:192:GLU:HG3	2.15	0.46
2:G:1:U:O2	1:B:108:LEU:HD21	2.15	0.46
1:K:234:ALA:HA	1:K:440:MET:HE2	1.98	0.46
1:B:39:PHE:CZ	1:B:67:VAL:HG22	2.51	0.46
1:B:410:PRO:HA	1:A:339:GLU:OE1	2.15	0.46
1:A:59:ASN:O	1:A:63:ILE:HG13	2.16	0.46
1:D:411:THR:HG23	1:D:412:PHE:CD2	2.50	0.46
1:B:41:ILE:O	1:B:45:THR:HG23	2.16	0.46
1:B:101:ASP:C	1:B:101:ASP:OD1	2.53	0.46
1:C:470:LYS:HB3	1:C:470:LYS:HZ3	1.80	0.46
1:K:284:ALA:HB2	1:K:306:LEU:HD11	1.96	0.46
1:J:20:GLN:O	1:J:23:THR:HG22	2.15	0.46
1:A:217:ILE:HD12	1:A:217:ILE:C	2.36	0.46

*Continued on next page...*

*Continued from previous page...*

Atom-1	Atom-2	Interatomic distance (Å)	Clash overlap (Å)
1:A:304:PHE:CD2	1:A:386:TRP:HB2	2.50	0.46
1:C:41:ILE:O	1:C:45:THR:HG23	2.16	0.46
1:B:92:THR:HG21	1:B:113:LYS:HE3	1.97	0.46
2:F:12:C:N4	2:F:13:U:O2	2.49	0.46
1:I:20:GLN:O	1:I:23:THR:HG22	2.15	0.46
1:K:300:GLY:O	1:K:389:ARG:NH2	2.48	0.46
1:B:370:ASN:OD1	1:B:370:ASN:C	2.54	0.46
1:B:426:MET:CE	1:A:449:GLU:HG2	2.45	0.46
1:A:189:MET:O	1:A:193:LEU:HG	2.16	0.46
1:C:370:ASN:OD1	1:C:370:ASN:C	2.54	0.46
1:B:200:GLY:HA2	1:B:206:PHE:HB3	1.97	0.45
1:C:39:PHE:CZ	1:C:67:VAL:HG22	2.51	0.45
1:C:166:LEU:HB3	1:C:187:GLY:N	2.30	0.45
1:B:406:ILE:CG2	1:A:162:ARG:HE	2.30	0.45
1:C:15:THR:HG22	1:C:16:ASP:N	2.29	0.45
1:C:411:THR:HG23	1:C:412:PHE:CD2	2.50	0.45
2:F:3:U:H2'	2:F:4:C:C6	2.51	0.45
1:A:100:VAL:HB	1:A:105:ARG:HH22	1.76	0.45
1:A:198:LYS:HE3	1:A:253:PHE:HE2	1.80	0.45
1:A:236:ARG:O	1:A:239:VAL:HG12	2.16	0.45
2:G:17:U:OP2	1:C:221:ARG:NH2	2.48	0.45
1:A:46:GLU:OE2	1:A:111:TYR:CE1	2.69	0.45
1:C:193:LEU:CD2	1:C:222:MET:HG3	2.44	0.45
1:J:384:ARG:HG2	1:J:384:ARG:NH1	2.32	0.45
1:B:133:LEU:HA	1:B:136:MET:CE	2.46	0.45
1:B:305:ARG:NH1	1:B:469:GLU:OE2	2.47	0.45
1:B:425:ILE:HD13	1:A:265:ILE:CD1	2.37	0.45
1:C:305:ARG:NH1	1:C:469:GLU:OE2	2.47	0.45
1:B:302:ASP:HB2	1:B:303:PRO:HD3	1.99	0.45
1:B:426:MET:CE	1:A:449:GLU:HA	2.47	0.45
1:A:15:THR:HG22	1:A:16:ASP:N	2.31	0.45
1:A:53:GLU:O	1:A:59:ASN:ND2	2.48	0.45
1:A:167:MET:HE2	1:A:187:GLY:CA	2.40	0.45
1:C:133:LEU:HA	1:C:136:MET:CE	2.46	0.45
2:G:12:C:N4	2:G:13:U:O2	2.49	0.45
1:K:317:ARG:NH1	1:K:369:GLU:OE2	2.50	0.45
1:K:408:ILE:HG13	1:K:419:PRO:HD2	1.99	0.45
1:B:166:LEU:HB3	1:B:187:GLY:N	2.30	0.45
1:A:39:PHE:CZ	1:A:67:VAL:CG2	3.00	0.45
1:C:302:ASP:HB2	1:C:303:PRO:HD3	1.99	0.45
2:G:3:U:H2'	2:G:4:C:C6	2.51	0.45

*Continued on next page...*

*Continued from previous page...*

Atom-1	Atom-2	Interatomic distance (Å)	Clash overlap (Å)
1:J:408:ILE:HG13	1:J:419:PRO:HD2	1.99	0.45
1:I:384:ARG:HG2	1:I:384:ARG:NH1	2.32	0.45
1:C:200:GLY:HA2	1:C:206:PHE:HB3	1.97	0.45
2:N:7:U:H5"	2:N:8:C:H5	1.81	0.45
1:B:193:LEU:CD2	1:B:222:MET:HG3	2.44	0.45
1:A:55:ARG:O	1:A:312:VAL:HG23	2.17	0.45
1:C:183:VAL:HG12	1:C:183:VAL:O	2.17	0.45
1:I:439:ASP:CB	1:B:246:ARG:HB3	2.42	0.44
1:B:183:VAL:O	1:B:183:VAL:HG12	2.17	0.44
1:C:112:ASP:OD1	1:C:112:ASP:N	2.50	0.44
1:B:15:THR:HG22	1:B:16:ASP:N	2.29	0.44
1:B:112:ASP:N	1:B:112:ASP:OD1	2.50	0.44
1:A:18:GLU:OE2	1:A:18:GLU:C	2.55	0.44
1:C:415:GLN:CG	1:C:415:GLN:O	2.65	0.44
1:J:317:ARG:NH1	1:J:369:GLU:OE2	2.50	0.44
1:A:39:PHE:CE1	1:A:43:MET:HG3	2.53	0.44
1:A:448:MET:HG2	1:A:448:MET:H	1.56	0.44
1:C:40:TYR:OH	1:C:54:GLY:O	2.27	0.44
2:F:17:U:OP2	1:B:221:ARG:NH2	2.48	0.44
1:D:415:GLN:O	1:D:415:GLN:CG	2.65	0.44
1:B:32:MET:HE2	1:B:131:ALA:HB1	1.98	0.44
1:B:154:LEU:CD2	1:B:159:MET:HE2	2.47	0.44
1:A:141:SER:OG	1:A:169:GLY:HA2	2.18	0.44
1:A:183:VAL:CG2	1:A:273:LYS:HD2	2.48	0.44
1:I:317:ARG:NH1	1:I:369:GLU:OE2	2.50	0.44
1:B:297:SER:O	1:B:303:PRO:HD3	2.18	0.44
1:A:77:LYS:HD2	1:A:77:LYS:HA	1.80	0.44
1:C:297:SER:O	1:C:303:PRO:HD3	2.18	0.44
1:K:384:ARG:HG2	1:K:384:ARG:NH1	2.32	0.44
1:J:109:ILE:HD12	1:J:109:ILE:O	2.18	0.44
1:I:109:ILE:HD12	1:I:109:ILE:O	2.17	0.44
1:B:410:PRO:HA	1:B:416:ARG:HH21	1.83	0.44
1:I:204:ARG:NH2	1:C:127:ASP:HB2	2.31	0.44
1:I:353:VAL:CG1	1:I:357:LYS:HB2	2.48	0.44
1:B:134:THR:HA	1:B:137:MET:HE2	1.99	0.44
1:A:24:GLU:OE1	1:A:24:GLU:HA	2.18	0.44
1:A:317:ARG:O	1:A:320:GLU:HB2	2.18	0.44
1:A:331:MET:HB3	1:A:331:MET:HE3	1.65	0.44
1:A:384:ARG:NH1	1:A:384:ARG:CG	2.80	0.44
1:J:353:VAL:CG1	1:J:357:LYS:HB2	2.48	0.44
1:A:39:PHE:CZ	1:A:67:VAL:HG21	2.52	0.43

*Continued on next page...*

*Continued from previous page...*

Atom-1	Atom-2	Interatomic distance (Å)	Clash overlap (Å)
1:A:109:ILE:HD13	1:A:109:ILE:HA	1.83	0.43
1:K:189:MET:HE3	1:K:189:MET:HB3	1.89	0.43
1:J:208:ARG:CZ	1:B:121:ARG:HD3	2.48	0.43
1:B:31:LYS:HB2	1:B:292:GLU:OE1	2.19	0.43
1:B:189:MET:HE1	1:B:225:ILE:CD1	2.48	0.43
1:B:411:THR:N	1:A:339:GLU:OE1	2.49	0.43
1:L:408:ILE:HG13	1:L:419:PRO:HD2	1.99	0.43
1:K:276:LEU:HD12	1:K:306:LEU:HD23	2.00	0.43
1:K:317:ARG:NH2	1:K:362:GLY:O	2.49	0.43
1:A:99:ARG:HD3	1:A:104:TRP:CZ2	2.53	0.43
1:K:109:ILE:HD12	1:K:109:ILE:O	2.18	0.43
1:B:205:ASN:HA	1:B:208:ARG:HH22	1.83	0.43
1:B:277:PRO:HG2	1:B:280:VAL:HG23	2.00	0.43
1:C:464:PHE:CD2	1:C:471:ALA:HA	2.53	0.43
2:E:12:C:H1'	2:E:13:U:P	2.57	0.43
1:K:353:VAL:CG1	1:K:357:LYS:HB2	2.48	0.43
1:A:60:SER:O	1:A:64:GLU:HG3	2.18	0.43
1:B:216:ARG:HD2	1:B:220:GLU:HG2	2.01	0.43
1:C:31:LYS:HB2	1:C:292:GLU:OE1	2.18	0.43
1:C:189:MET:HE3	1:C:225:ILE:CG1	2.30	0.43
1:C:216:ARG:HD2	1:C:220:GLU:HG2	2.01	0.43
2:G:11:U:H4'	1:C:25:ILE:HG13	2.01	0.43
1:K:167:MET:HE3	1:K:188:THR:HG22	2.00	0.43
1:J:276:LEU:HD12	1:J:306:LEU:HD23	2.00	0.43
1:B:464:PHE:CD2	1:B:471:ALA:HA	2.53	0.43
1:K:351:LYS:NZ	1:K:351:LYS:HB3	2.33	0.43
1:C:277:PRO:HG2	1:C:280:VAL:HG23	2.00	0.43
2:F:11:U:H4'	1:B:25:ILE:HG13	2.01	0.43
1:K:124:ASN:ND2	1:K:129:ALA:HB3	2.34	0.43
1:B:384:ARG:HH11	1:B:384:ARG:CG	2.32	0.43
1:L:416:ARG:HH12	1:K:339:GLU:CD	2.22	0.42
2:O:7:U:C4	1:J:161:PRO:HG3	2.54	0.42
2:G:13:U:HO2'	2:G:14:C:H6	1.65	0.42
1:K:307:LEU:HD23	1:K:307:LEU:HA	1.91	0.42
1:J:124:ASN:ND2	1:J:129:ALA:HB3	2.34	0.42
1:J:351:LYS:NZ	1:J:351:LYS:HB3	2.33	0.42
1:I:276:LEU:HD12	1:I:306:LEU:HD23	2.00	0.42
1:B:405:GLN:N	1:A:489:PHE:O	2.46	0.42
1:A:385:TYR:HB3	1:A:463:VAL:HG11	1.97	0.42
1:B:324:HIS:CB	1:B:358:LEU:HD22	2.47	0.42
1:C:189:MET:HE1	1:C:225:ILE:CD1	2.49	0.42

*Continued on next page...*

*Continued from previous page...*

Atom-1	Atom-2	Interatomic distance (Å)	Clash overlap (Å)
1:K:62:THR:HG23	1:K:94:GLY:HA3	2.01	0.42
1:K:416:ARG:HH12	1:J:339:GLU:CD	2.22	0.42
1:B:248:PRO:HA	1:B:252:GLU:CD	2.40	0.42
1:A:143:LEU:HA	1:A:332:ALA:CB	2.50	0.42
1:A:252:GLU:OE1	1:A:252:GLU:N	2.39	0.42
1:C:248:PRO:HA	1:C:252:GLU:CD	2.40	0.42
1:I:204:ARG:HE	1:C:126:GLY:C	2.20	0.42
1:C:384:ARG:HH11	1:C:384:ARG:CG	2.32	0.42
3:F:601:A1IJK:C20	3:F:601:A1IJK:O18	2.68	0.42
3:G:601:A1IJK:O26	1:I:216:ARG:CB	2.68	0.42
1:J:62:THR:HG23	1:J:94:GLY:HA3	2.01	0.42
1:B:39:PHE:CZ	1:B:67:VAL:CG2	3.03	0.42
1:A:451:ALA:O	1:A:452:ARG:HD3	2.19	0.42
1:C:16:ASP:OD1	1:C:16:ASP:O	2.37	0.42
2:F:18:C:P	1:B:214:ARG:HH21	2.42	0.42
3:G:601:A1IJK:C20	3:G:601:A1IJK:O18	2.68	0.42
1:I:351:LYS:NZ	1:I:351:LYS:HB3	2.33	0.42
1:B:448:MET:HE1	1:C:429:PHE:CZ	2.55	0.42
1:A:32:MET:CE	1:A:131:ALA:HB1	2.50	0.42
2:F:13:U:HO2'	2:F:14:C:H6	1.65	0.42
1:J:216:ARG:HA	1:J:216:ARG:HD2	1.92	0.42
1:J:317:ARG:NH2	1:J:362:GLY:O	2.49	0.42
1:B:16:ASP:OD1	1:B:16:ASP:O	2.37	0.42
1:B:422:ARG:HB3	1:B:423:PRO:HD3	2.01	0.42
1:A:174:ARG:HB2	1:A:174:ARG:HH11	1.84	0.42
1:C:233:ALA:O	1:C:237:THR:HG23	2.20	0.42
1:C:301:ILE:HG12	1:C:301:ILE:O	2.19	0.42
1:L:415:GLN:O	1:L:416:ARG:O	2.38	0.42
1:B:233:ALA:O	1:B:237:THR:HG23	2.20	0.42
1:B:301:ILE:HG12	1:B:301:ILE:O	2.19	0.42
1:K:163:MET:HB2	1:K:166:LEU:HD12	2.02	0.42
1:J:416:ARG:HH12	1:I:339:GLU:CD	2.22	0.42
1:B:184:LYS:HB3	1:B:184:LYS:HE3	1.87	0.42
2:N:7:U:H1'	1:I:155:VAL:HG21	2.02	0.42
1:J:405:GLN:HB3	1:I:487:TYR:HB3	2.01	0.42
1:B:76:ASN:HD21	1:B:113:LYS:HE2	1.85	0.42
1:C:76:ASN:HD21	1:C:113:LYS:HE2	1.84	0.42
1:C:293:ARG:HG3	1:C:293:ARG:NH1	2.35	0.42
2:G:18:C:P	1:C:214:ARG:HH21	2.42	0.41
1:A:124:ASN:HD22	1:A:129:ALA:HB3	1.85	0.41
1:A:221:ARG:HH11	1:A:221:ARG:HB2	1.84	0.41

*Continued on next page...*



*Continued from previous page...*

Atom-1	Atom-2	Interatomic distance (Å)	Clash overlap (Å)
1:C:15:THR:HA	1:C:18:GLU:HG3	2.02	0.41
1:D:429:PHE:CZ	1:C:448:MET:HE1	2.55	0.41
1:A:16:ASP:OD1	1:A:16:ASP:O	2.38	0.41
1:I:62:THR:HG23	1:I:94:GLY:HA3	2.01	0.41
1:I:124:ASN:ND2	1:I:129:ALA:HB3	2.34	0.41
1:C:39:PHE:CZ	1:C:67:VAL:CG2	3.03	0.41
1:C:160:ASP:OD2	1:C:162:ARG:HB2	2.21	0.41
1:L:405:GLN:HB3	1:K:487:TYR:HB3	2.01	0.41
1:J:137:MET:CE	1:J:173:PRO:HG2	2.51	0.41
1:I:216:ARG:HA	1:I:216:ARG:HD2	1.92	0.41
1:A:181:ALA:HB1	1:A:225:ILE:HD12	2.01	0.41
1:K:415:GLN:O	1:K:416:ARG:O	2.38	0.41
1:J:415:GLN:O	1:J:416:ARG:O	2.38	0.41
1:I:163:MET:HB2	1:I:166:LEU:HD12	2.02	0.41
1:B:274:SER:HA	1:B:333:CYS:O	2.21	0.41
1:A:259:LEU:HD23	1:A:259:LEU:HA	1.92	0.41
1:B:15:THR:HA	1:B:18:GLU:HG3	2.02	0.41
1:A:238:MET:CE	1:A:444:ILE:HD12	2.49	0.41
3:G:601:A1IJK:C7	1:I:246:ARG:NH1	2.83	0.41
1:I:351:LYS:HB3	1:I:351:LYS:HZ1	1.85	0.41
1:A:143:LEU:HA	1:A:332:ALA:HB1	2.02	0.41
1:A:340:ASP:HB3	1:A:343:VAL:CG1	2.41	0.41
1:C:211:ASN:OD1	1:C:214:ARG:HD3	2.21	0.41
2:O:3:U:OP1	1:J:367:SER:N	2.48	0.41
2:P:3:U:OP1	1:K:367:SER:N	2.48	0.41
2:G:1:U:OP3	1:B:75:ARG:NH2	2.48	0.41
1:J:163:MET:HB2	1:J:166:LEU:HD12	2.02	0.41
1:I:317:ARG:NH2	1:I:362:GLY:O	2.49	0.41
1:B:440:MET:HE2	1:B:442:THR:H	1.86	0.41
1:A:150:ARG:HD3	1:A:170:SER:OG	2.20	0.41
1:A:151:THR:O	1:A:155:VAL:HG12	2.21	0.41
1:K:405:GLN:HB3	1:J:487:TYR:HB3	2.01	0.41
1:I:481:MET:H	1:I:481:MET:HE3	1.85	0.41
1:B:160:ASP:OD2	1:B:162:ARG:HB2	2.21	0.41
1:B:214:ARG:HH11	1:B:214:ARG:HG2	1.86	0.41
1:B:293:ARG:HG3	1:B:293:ARG:NH1	2.35	0.41
1:A:159:MET:HB3	1:A:163:MET:CE	2.51	0.41
1:C:53:GLU:H	1:C:53:GLU:HG3	1.72	0.41
1:C:274:SER:HA	1:C:333:CYS:O	2.21	0.41
1:I:438:SER:HB2	1:B:247:ASN:HD22	1.86	0.41
1:B:80:GLU:HA	1:B:89:PRO:HG3	2.04	0.41

*Continued on next page...*

Continued from previous page...

Atom-1	Atom-2	Interatomic distance (Å)	Clash overlap (Å)
1:C:80:GLU:HA	1:C:89:PRO:HG3	2.03	0.41
1:C:217:ILE:O	1:C:217:ILE:HD12	2.21	0.41
2:E:12:C:C1'	2:E:13:U:P	3.09	0.40
1:J:137:MET:HE3	1:J:175:ARG:HG3	2.03	0.40
1:B:232:THR:HG21	1:B:266:LEU:HD13	2.03	0.40
1:A:152:ARG:HA	1:A:155:VAL:HG12	2.03	0.40
1:A:200:GLY:HA2	1:A:206:PHE:HB3	2.03	0.40
1:A:235:GLN:HG2	1:A:259:LEU:CD2	2.51	0.40
1:C:32:MET:HE1	1:C:131:ALA:HB1	2.03	0.40
1:C:214:ARG:HG2	1:C:214:ARG:HH11	1.87	0.40
1:D:426:MET:HE1	1:C:449:GLU:HA	2.04	0.40
1:B:216:ARG:HE	1:B:220:GLU:CD	2.24	0.40
1:A:252:GLU:O	1:A:255:ASP:OD1	2.39	0.40
1:C:464:PHE:CD1	1:C:464:PHE:N	2.90	0.40
2:F:16:C:H1'	1:B:174:ARG:CD	2.49	0.40
1:K:77:LYS:HE2	1:K:77:LYS:HB2	1.94	0.40
1:B:203:ASP:OD1	1:B:205:ASN:HB3	2.22	0.40
2:G:18:C:H3'	3:G:601:A1IJK:C3	2.51	0.40
1:B:185:GLY:HA2	1:B:270:VAL:HG22	2.03	0.40
1:C:185:GLY:HA2	1:C:270:VAL:HG22	2.03	0.40
1:C:440:MET:HE2	1:C:442:THR:H	1.86	0.40
2:F:18:C:H3'	3:F:601:A1IJK:C3	2.52	0.40
1:I:151:THR:HA	1:I:154:LEU:HD12	2.04	0.40
1:A:100:VAL:O	1:A:101:ASP:HB2	2.22	0.40

There are no symmetry-related clashes.

## 5.3 Torsion angles [i](#)

### 5.3.1 Protein backbone [i](#)

In the following table, the Percentiles column shows the percent Ramachandran outliers of the chain as a percentile score with respect to all PDB entries followed by that with respect to all EM entries.

The Analysed column shows the number of residues for which the backbone conformation was analysed, and the total number of residues.

Mol	Chain	Analysed	Favoured	Allowed	Outliers	Percentiles
1	A	422/494 (85%)	410 (97%)	11 (3%)	1 (0%)	44 75

Continued on next page...

Continued from previous page...

Mol	Chain	Analysed	Favoured	Allowed	Outliers	Percentiles	
1	B	446/494 (90%)	428 (96%)	17 (4%)	1 (0%)	44	75
1	C	446/494 (90%)	429 (96%)	16 (4%)	1 (0%)	44	75
1	D	24/494 (5%)	22 (92%)	2 (8%)	0	100	100
1	I	430/494 (87%)	417 (97%)	13 (3%)	0	100	100
1	J	456/494 (92%)	441 (97%)	14 (3%)	1 (0%)	44	75
1	K	456/494 (92%)	441 (97%)	14 (3%)	1 (0%)	44	75
1	L	26/494 (5%)	24 (92%)	1 (4%)	1 (4%)	2	18
All	All	2706/3952 (68%)	2612 (96%)	88 (3%)	6 (0%)	45	75

All (6) Ramachandran outliers are listed below:

Mol	Chain	Res	Type
1	L	416	ARG
1	K	416	ARG
1	J	416	ARG
1	B	178	ALA
1	A	178	ALA
1	C	178	ALA

### 5.3.2 Protein sidechains [i](#)

In the following table, the Percentiles column shows the percent sidechain outliers of the chain as a percentile score with respect to all PDB entries followed by that with respect to all EM entries.

The Analysed column shows the number of residues for which the sidechain conformation was analysed, and the total number of residues.

Mol	Chain	Analysed	Rotameric	Outliers	Percentiles	
1	A	361/420 (86%)	346 (96%)	15 (4%)	25	58
1	B	384/420 (91%)	360 (94%)	24 (6%)	15	46
1	C	384/420 (91%)	360 (94%)	24 (6%)	15	46
1	D	23/420 (6%)	22 (96%)	1 (4%)	25	57
1	I	368/420 (88%)	358 (97%)	10 (3%)	40	69
1	J	393/420 (94%)	383 (98%)	10 (2%)	42	71
1	K	393/420 (94%)	383 (98%)	10 (2%)	42	71
1	L	25/420 (6%)	25 (100%)	0	100	100

Continued on next page...

*Continued from previous page...*

Mol	Chain	Analysed	Rotameric	Outliers	Percentiles
All	All	2331/3360 (69%)	2237 (96%)	94 (4%)	29 59

All (94) residues with a non-rotameric sidechain are listed below:

Mol	Chain	Res	Type
1	D	416	ARG
1	K	73	GLU
1	K	106	ARG
1	K	111	TYR
1	K	160	ASP
1	K	204	ARG
1	K	229	LYS
1	K	240	ASP
1	K	253	PHE
1	K	283	SER
1	K	481	MET
1	J	73	GLU
1	J	106	ARG
1	J	111	TYR
1	J	160	ASP
1	J	204	ARG
1	J	229	LYS
1	J	240	ASP
1	J	253	PHE
1	J	283	SER
1	J	481	MET
1	I	73	GLU
1	I	106	ARG
1	I	111	TYR
1	I	160	ASP
1	I	204	ARG
1	I	229	LYS
1	I	240	ASP
1	I	253	PHE
1	I	283	SER
1	I	481	MET
1	B	26	ARG
1	B	31	LYS
1	B	51	ASP
1	B	74	ARG
1	B	101	ASP
1	B	103	LYS

*Continued on next page...*

*Continued from previous page...*

<b>Mol</b>	<b>Chain</b>	<b>Res</b>	<b>Type</b>
1	B	106	ARG
1	B	111	TYR
1	B	112	ASP
1	B	162	ARG
1	B	164	CYS
1	B	174	ARG
1	B	204	ARG
1	B	221	ARG
1	B	240	ASP
1	B	253	PHE
1	B	255	ASP
1	B	269	SER
1	B	372	GLU
1	B	384	ARG
1	B	448	MET
1	B	452	ARG
1	B	457	SER
1	B	470	LYS
1	A	18	GLU
1	A	26	ARG
1	A	46	GLU
1	A	48	LYS
1	A	112	ASP
1	A	136	MET
1	A	163	MET
1	A	199	ARG
1	A	206	PHE
1	A	213	ARG
1	A	250	ASN
1	A	305	ARG
1	A	448	MET
1	A	461	ARG
1	A	464	PHE
1	C	26	ARG
1	C	31	LYS
1	C	74	ARG
1	C	101	ASP
1	C	103	LYS
1	C	106	ARG
1	C	111	TYR
1	C	112	ASP
1	C	162	ARG

*Continued on next page...*

*Continued from previous page...*

Mol	Chain	Res	Type
1	C	164	CYS
1	C	174	ARG
1	C	204	ARG
1	C	221	ARG
1	C	240	ASP
1	C	253	PHE
1	C	255	ASP
1	C	269	SER
1	C	372	GLU
1	C	384	ARG
1	C	416	ARG
1	C	448	MET
1	C	452	ARG
1	C	457	SER
1	C	470	LYS

Sometimes sidechains can be flipped to improve hydrogen bonding and reduce clashes. All (5) such sidechains are listed below:

Mol	Chain	Res	Type
1	B	247	ASN
1	B	364	GLN
1	B	405	GLN
1	A	247	ASN
1	C	364	GLN

### 5.3.3 RNA [i](#)

Mol	Chain	Analysed	Backbone Outliers	Pucker Outliers
2	E	10/18 (55%)	8 (80%)	1 (10%)
2	F	17/18 (94%)	7 (41%)	0
2	G	17/18 (94%)	7 (41%)	0
2	H	6/18 (33%)	1 (16%)	0
2	M	10/18 (55%)	6 (60%)	0
2	N	17/18 (94%)	10 (58%)	0
2	O	17/18 (94%)	7 (41%)	1 (5%)
2	P	6/18 (33%)	2 (33%)	0
All	All	100/144 (69%)	48 (48%)	2 (2%)

All (48) RNA backbone outliers are listed below:

Mol	Chain	Res	Type
2	O	5	U
2	O	12	C
2	O	13	U
2	O	14	C
2	O	15	U
2	O	17	U
2	O	18	C
2	P	5	U
2	P	7	U
2	M	12	C
2	M	13	U
2	M	14	C
2	M	15	U
2	M	17	U
2	M	18	C
2	N	5	U
2	N	7	U
2	N	8	C
2	N	9	U
2	N	12	C
2	N	13	U
2	N	14	C
2	N	15	U
2	N	17	U
2	N	18	C
2	E	9	U
2	E	10	C
2	E	12	C
2	E	13	U
2	E	14	C
2	E	15	U
2	E	17	U
2	E	18	C
2	F	5	U
2	F	9	U
2	F	12	C
2	F	13	U
2	F	15	U
2	F	17	U
2	F	18	C
2	G	5	U
2	G	9	U
2	G	12	C

*Continued on next page...*

Continued from previous page...

Mol	Chain	Res	Type
2	G	13	U
2	G	15	U
2	G	17	U
2	G	18	C
2	H	5	U

All (2) RNA pucker outliers are listed below:

Mol	Chain	Res	Type
2	O	8	C
2	E	12	C

## 5.4 Non-standard residues in protein, DNA, RNA chains [i](#)

There are no non-standard protein/DNA/RNA residues in this entry.

## 5.5 Carbohydrates [i](#)

There are no oligosaccharides in this entry.

## 5.6 Ligand geometry [i](#)

6 ligands are modelled in this entry.

In the following table, the Counts columns list the number of bonds (or angles) for which Mogul statistics could be retrieved, the number of bonds (or angles) that are observed in the model and the number of bonds (or angles) that are defined in the Chemical Component Dictionary. The Link column lists molecule types, if any, to which the group is linked. The Z score for a bond length (or angle) is the number of standard deviations the observed value is removed from the expected value. A bond length (or angle) with  $|Z| > 2$  is considered an outlier worth inspection. RMSZ is the root-mean-square of all Z scores of the bond lengths (or angles).

Mol	Type	Chain	Res	Link	Bond lengths			Bond angles		
					Counts	RMSZ	# Z  > 2	Counts	RMSZ	# Z  > 2
3	A1IJK	N	101	2	34,39,39	1.40	9 (26%)	44,55,55	0.88	2 (4%)
3	A1IJK	O	101	2	34,39,39	1.40	9 (26%)	44,55,55	0.88	2 (4%)
3	A1IJK	G	601	2	34,39,39	1.41	9 (26%)	44,55,55	0.82	1 (2%)
3	A1IJK	M	101	2	34,39,39	1.40	9 (26%)	44,55,55	0.88	2 (4%)
3	A1IJK	F	601	2	34,39,39	1.41	9 (26%)	44,55,55	0.82	1 (2%)
3	A1IJK	E	601	2	34,39,39	1.41	9 (26%)	44,55,55	0.85	2 (4%)



In the following table, the Chirals column lists the number of chiral outliers, the number of chiral centers analysed, the number of these observed in the model and the number defined in the Chemical Component Dictionary. Similar counts are reported in the Torsion and Rings columns. '-' means no outliers of that kind were identified.

Mol	Type	Chain	Res	Link	Chirals	Torsions	Rings
3	A1IJK	N	101	2	-	0/21/59/59	0/4/4/4
3	A1IJK	O	101	2	-	0/21/59/59	0/4/4/4
3	A1IJK	G	601	2	-	1/21/59/59	0/4/4/4
3	A1IJK	M	101	2	-	0/21/59/59	0/4/4/4
3	A1IJK	F	601	2	-	1/21/59/59	0/4/4/4
3	A1IJK	E	601	2	-	3/21/59/59	0/4/4/4

All (54) bond length outliers are listed below:

Mol	Chain	Res	Type	Atoms	Z	Observed(Å)	Ideal(Å)
3	G	601	A1IJK	C33-C32	-3.75	1.38	1.46
3	E	601	A1IJK	C33-C32	-3.72	1.38	1.46
3	F	601	A1IJK	C33-C32	-3.71	1.38	1.46
3	M	101	A1IJK	C33-C32	-3.66	1.38	1.46
3	O	101	A1IJK	C33-C32	-3.65	1.38	1.46
3	N	101	A1IJK	C33-C32	-3.64	1.38	1.46
3	E	601	A1IJK	C25-C34	-2.51	1.39	1.44
3	M	101	A1IJK	C25-C34	-2.49	1.39	1.44
3	O	101	A1IJK	C25-C34	-2.48	1.39	1.44
3	E	601	A1IJK	C29-C30	2.48	1.38	1.34
3	N	101	A1IJK	C21-C30	-2.47	1.39	1.44
3	O	101	A1IJK	C21-C30	-2.46	1.39	1.44
3	M	101	A1IJK	C21-C30	-2.45	1.39	1.44
3	N	101	A1IJK	C25-C34	-2.45	1.39	1.44
3	F	601	A1IJK	C29-C30	2.43	1.38	1.34
3	G	601	A1IJK	C29-C30	2.42	1.38	1.34
3	G	601	A1IJK	C25-C34	-2.42	1.39	1.44
3	G	601	A1IJK	C25-C20	2.41	1.45	1.41
3	N	101	A1IJK	C25-C20	2.40	1.45	1.41
3	O	101	A1IJK	C25-C20	2.38	1.45	1.41
3	E	601	A1IJK	C21-C20	2.38	1.45	1.41
3	F	601	A1IJK	C25-C34	-2.38	1.39	1.44
3	F	601	A1IJK	C25-C20	2.38	1.45	1.41
3	F	601	A1IJK	C21-C30	-2.35	1.39	1.44
3	M	101	A1IJK	C25-C20	2.35	1.45	1.41
3	G	601	A1IJK	C21-C30	-2.34	1.39	1.44
3	G	601	A1IJK	C21-C20	2.33	1.45	1.41
3	E	601	A1IJK	C21-C30	-2.30	1.40	1.44
3	F	601	A1IJK	C21-C20	2.29	1.45	1.41

*Continued on next page...*

Continued from previous page...

Mol	Chain	Res	Type	Atoms	Z	Observed(Å)	Ideal(Å)
3	E	601	A1IJK	C25-C20	2.29	1.45	1.41
3	F	601	A1IJK	O23-C22	2.27	1.38	1.35
3	O	101	A1IJK	O23-C24	2.26	1.38	1.35
3	N	101	A1IJK	O23-C24	2.26	1.38	1.35
3	N	101	A1IJK	C29-C30	2.24	1.38	1.34
3	M	101	A1IJK	O23-C24	2.24	1.38	1.35
3	M	101	A1IJK	O23-C22	2.23	1.38	1.35
3	E	601	A1IJK	O23-C24	2.22	1.38	1.35
3	O	101	A1IJK	O23-C22	2.21	1.38	1.35
3	O	101	A1IJK	C29-C30	2.21	1.38	1.34
3	E	601	A1IJK	O23-C22	2.20	1.38	1.35
3	M	101	A1IJK	C29-C30	2.20	1.38	1.34
3	N	101	A1IJK	O23-C22	2.20	1.38	1.35
3	G	601	A1IJK	O23-C22	2.19	1.38	1.35
3	G	601	A1IJK	O23-C24	2.15	1.38	1.35
3	F	601	A1IJK	O23-C24	2.15	1.38	1.35
3	N	101	A1IJK	C27-C28	2.12	1.45	1.39
3	M	101	A1IJK	C27-C28	2.12	1.45	1.39
3	G	601	A1IJK	C27-C28	2.11	1.45	1.39
3	O	101	A1IJK	C27-C28	2.11	1.45	1.39
3	F	601	A1IJK	C27-C28	2.11	1.45	1.39
3	M	101	A1IJK	C21-C20	2.10	1.45	1.41
3	O	101	A1IJK	C21-C20	2.09	1.45	1.41
3	N	101	A1IJK	C21-C20	2.09	1.45	1.41
3	E	601	A1IJK	C27-C28	2.06	1.45	1.39

All (10) bond angle outliers are listed below:

Mol	Chain	Res	Type	Atoms	Z	Observed(°)	Ideal(°)
3	N	101	A1IJK	C20-C21-C30	-2.36	119.85	124.50
3	O	101	A1IJK	C20-C21-C30	-2.36	119.85	124.50
3	M	101	A1IJK	C20-C21-C30	-2.34	119.89	124.50
3	G	601	A1IJK	C20-C21-C30	-2.14	120.27	124.50
3	F	601	A1IJK	C20-C21-C30	-2.14	120.28	124.50
3	M	101	A1IJK	C15-C20-C21	-2.12	119.90	122.77
3	N	101	A1IJK	C15-C20-C21	-2.10	119.94	122.77
3	O	101	A1IJK	C15-C20-C21	-2.09	119.95	122.77
3	E	601	A1IJK	C20-C25-C34	-2.07	120.42	124.50
3	E	601	A1IJK	C20-C21-C30	-2.06	120.43	124.50

There are no chirality outliers.

All (5) torsion outliers are listed below:

Mol	Chain	Res	Type	Atoms
3	F	601	A1IJK	C6-C7-C8-N9
3	G	601	A1IJK	C6-C7-C8-N9
3	E	601	A1IJK	C7-C8-N9-C10
3	E	601	A1IJK	C11-C10-N9-C8
3	E	601	A1IJK	O26-C10-N9-C8

There are no ring outliers.

3 monomers are involved in 11 short contacts:

Mol	Chain	Res	Type	Clashes	Symm-Clashes
3	G	601	A1IJK	8	0
3	F	601	A1IJK	2	0
3	E	601	A1IJK	1	0

The following is a two-dimensional graphical depiction of Mogul quality analysis of bond lengths, bond angles, torsion angles, and ring geometry for all instances of the Ligand of Interest. In addition, ligands with molecular weight > 250 and outliers as shown on the validation Tables will also be included. For torsion angles, if less than 5% of the Mogul distribution of torsion angles is within 10 degrees of the torsion angle in question, then that torsion angle is considered an outlier. Any bond that is central to one or more torsion angles identified as an outlier by Mogul will be highlighted in the graph. For rings, the root-mean-square deviation (RMSD) between the ring in question and similar rings identified by Mogul is calculated over all ring torsion angles. If the average RMSD is greater than 60 degrees and the minimal RMSD between the ring in question and any Mogul-identified rings is also greater than 60 degrees, then that ring is considered an outlier. The outliers are highlighted in purple. The color gray indicates Mogul did not find sufficient equivalents in the CSD to analyse the geometry.

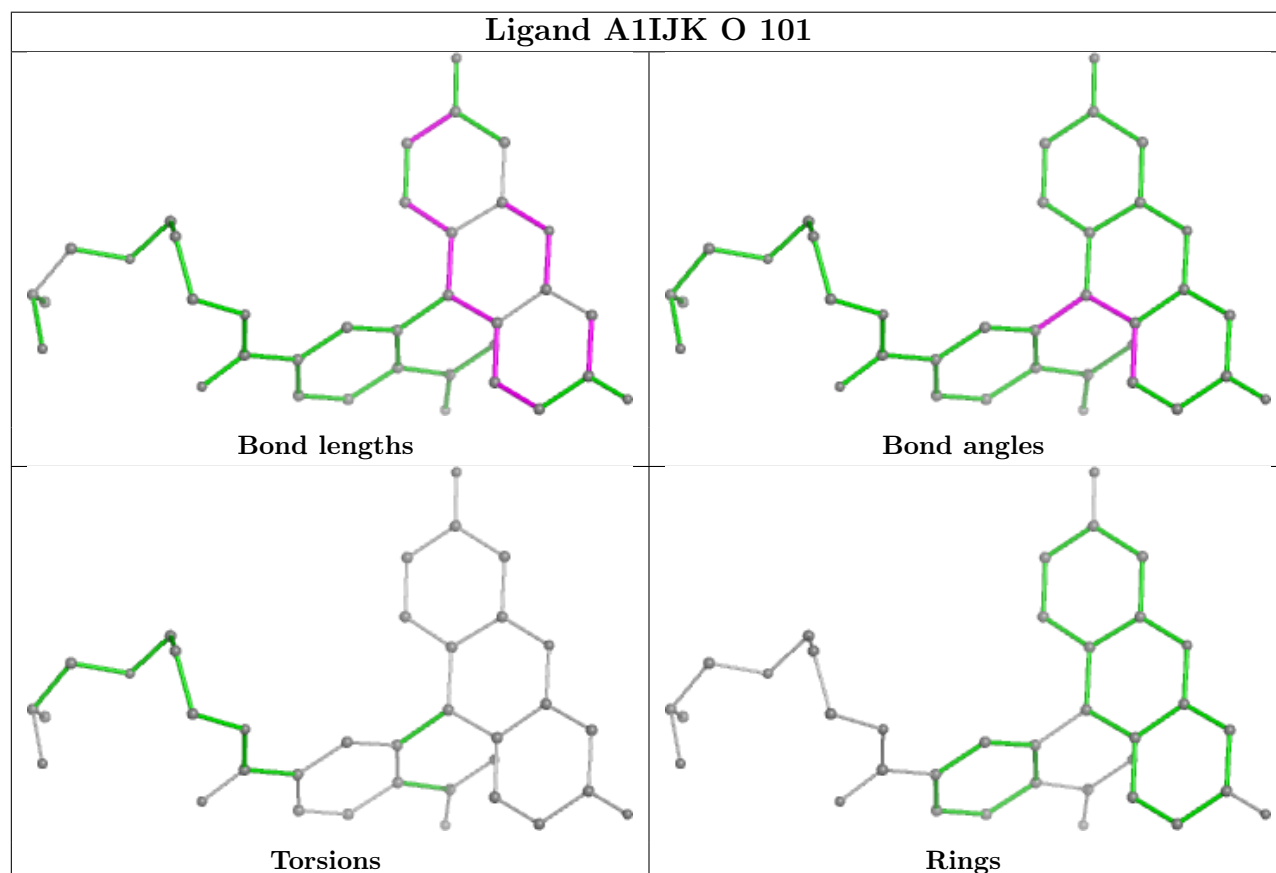
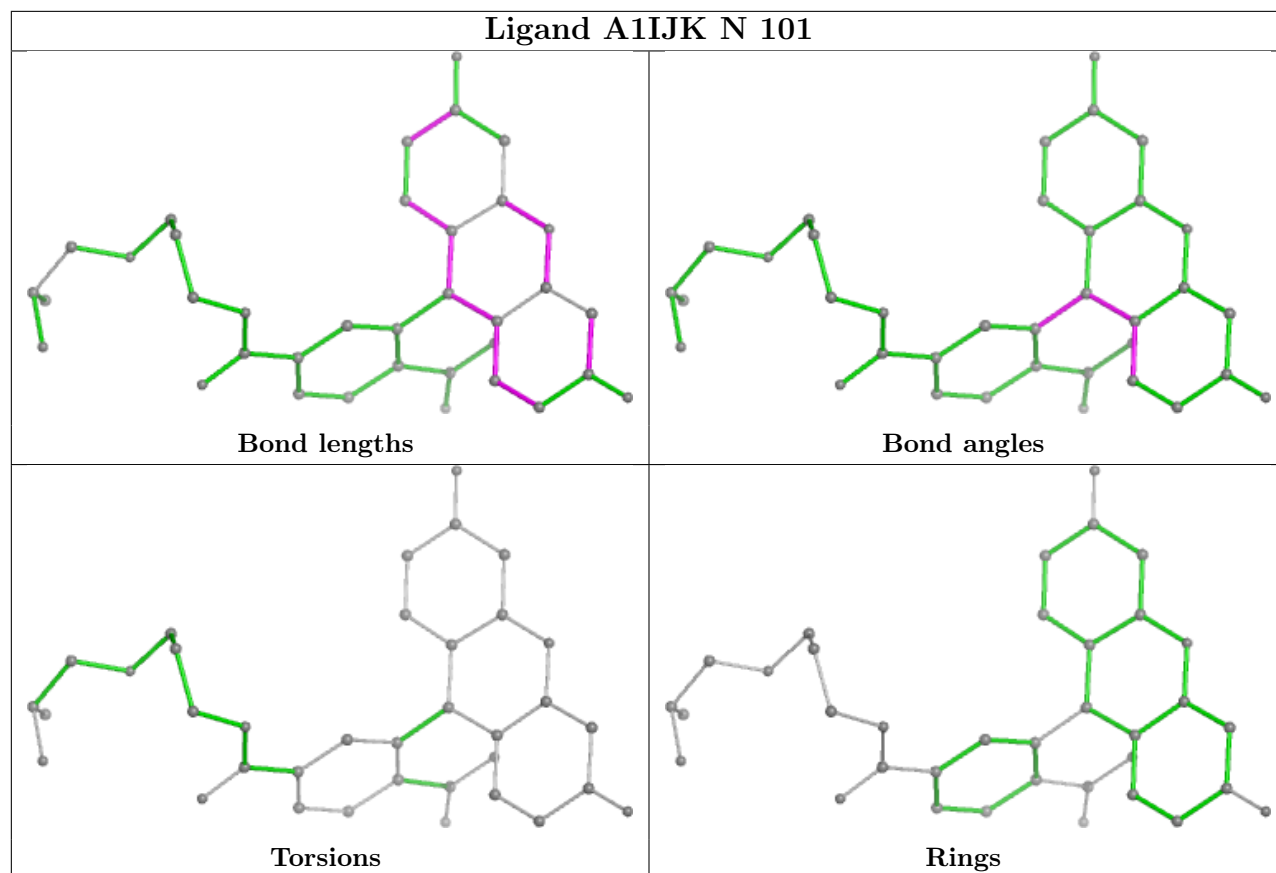

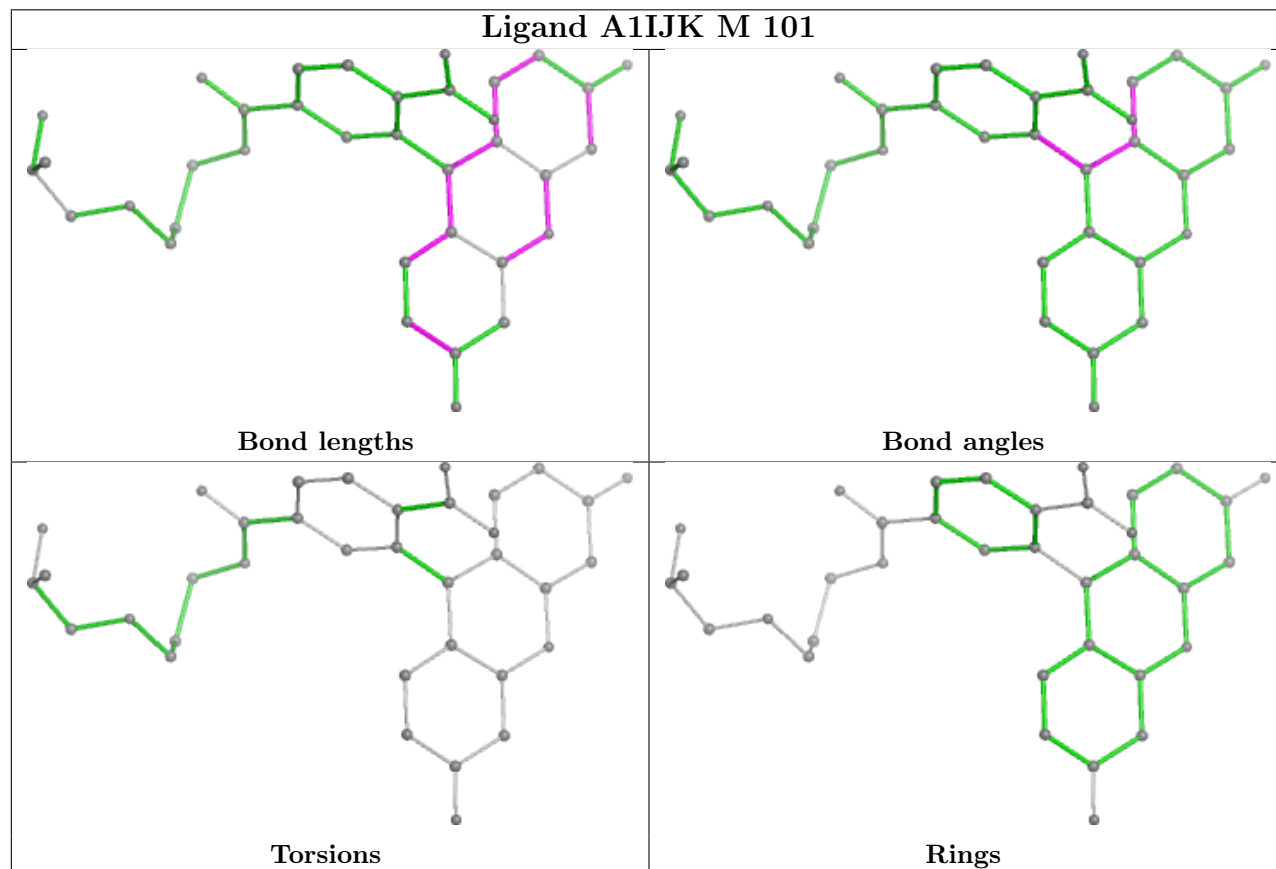
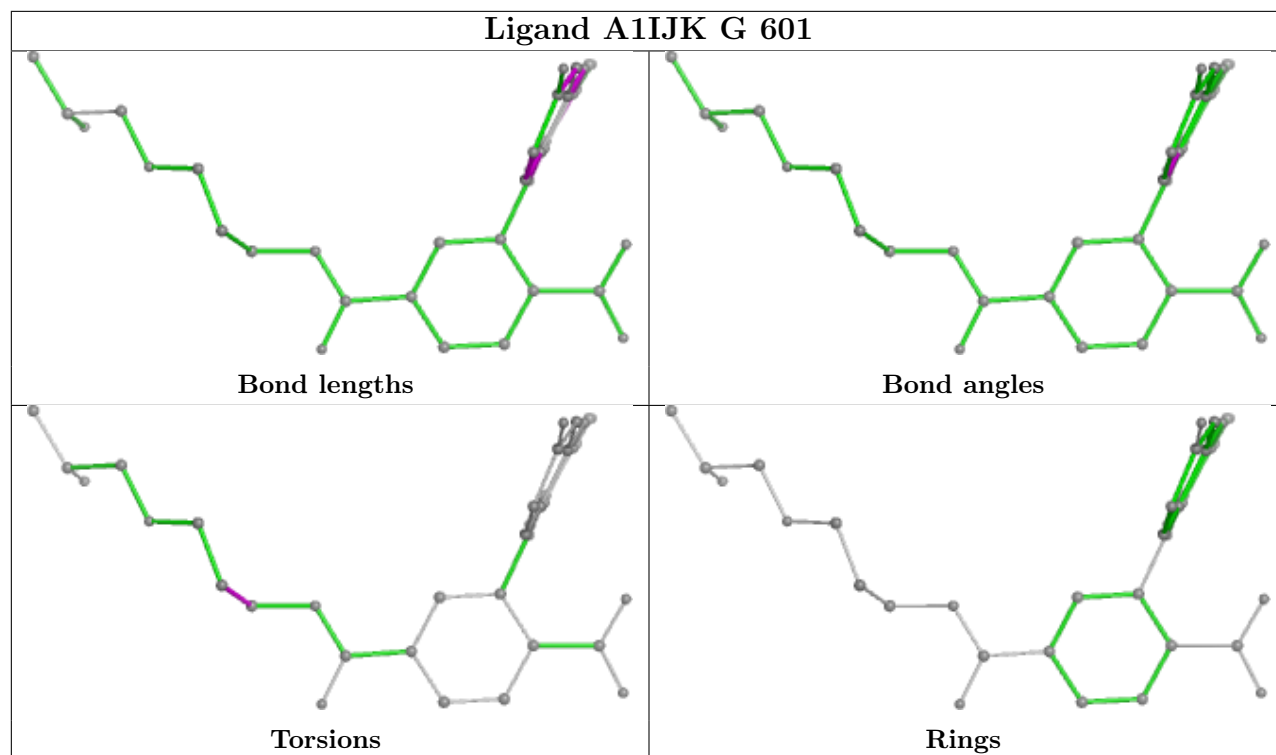

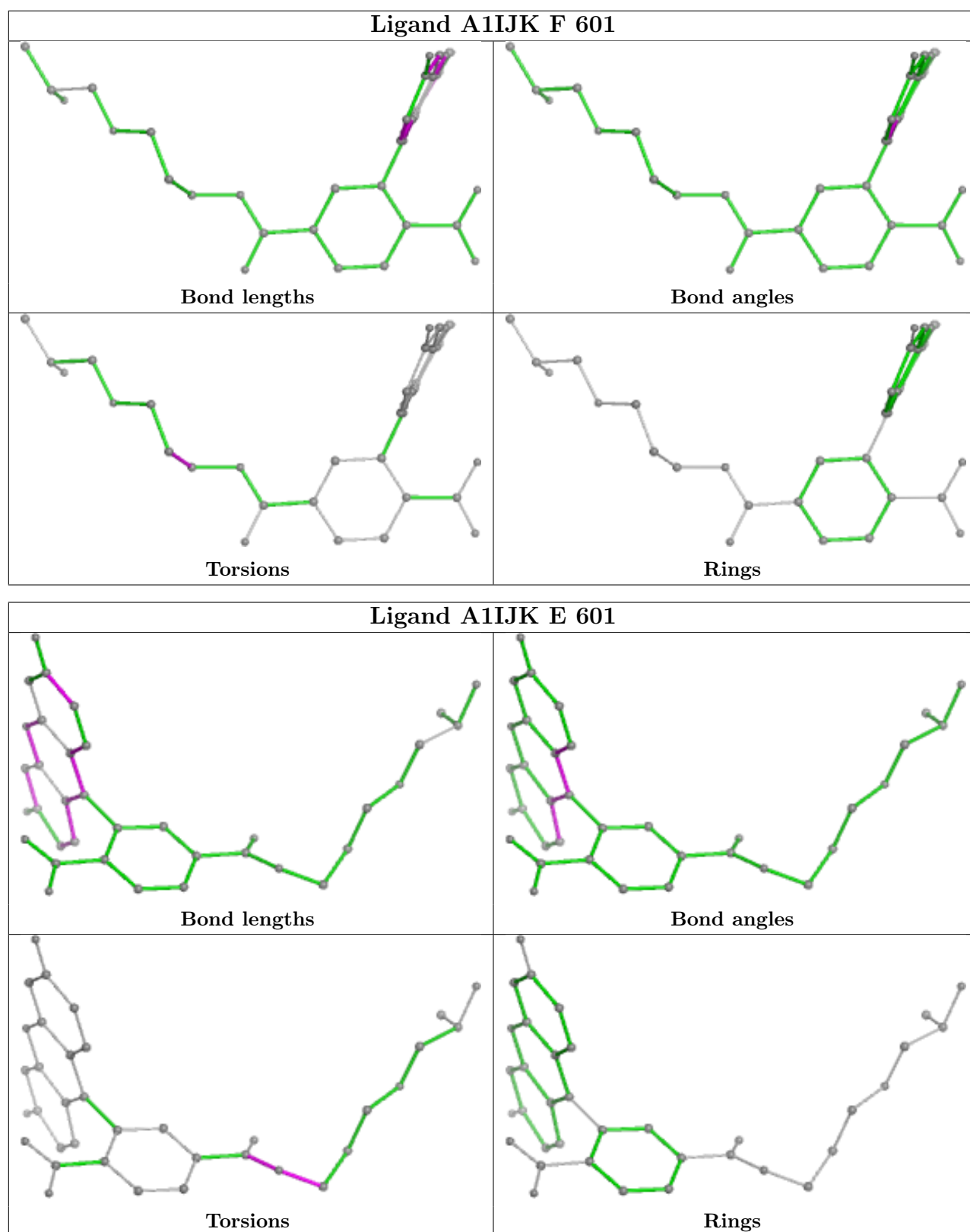

## 5.7 Other polymers [i](#)

There are no such residues in this entry.

## 5.8 Polymer linkage issues

There are no chain breaks in this entry.

## 6 Map visualisation [i](#)

This section contains visualisations of the EMDB entry EMD-51188. These allow visual inspection of the internal detail of the map and identification of artifacts.

Images derived from a raw map, generated by summing the deposited half-maps, are presented below the corresponding image components of the primary map to allow further visual inspection and comparison with those of the primary map.

### 6.1 Orthogonal projections [i](#)

#### 6.1.1 Primary map

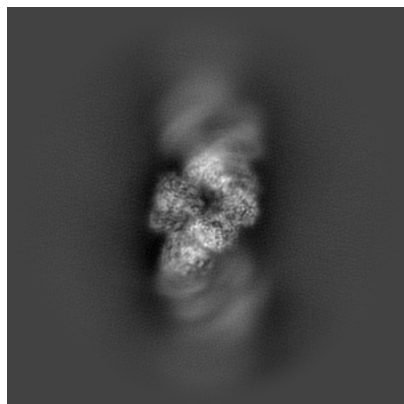

X

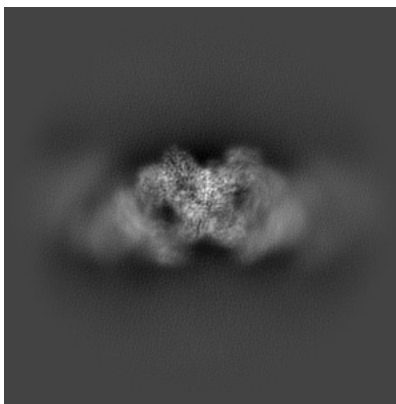

Y

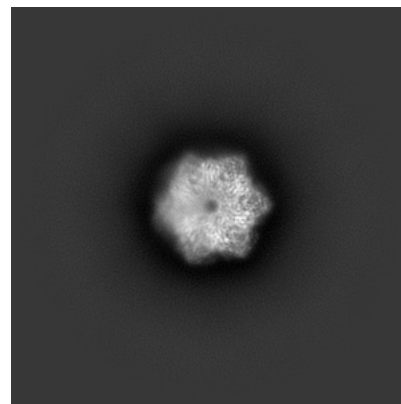

Z

#### 6.1.2 Raw map

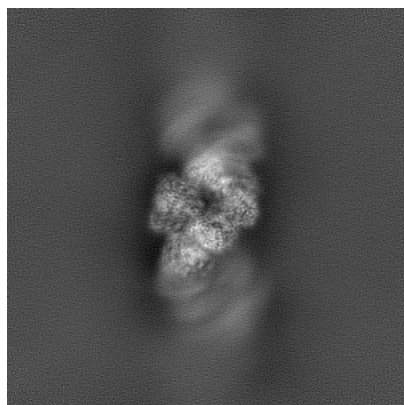

X

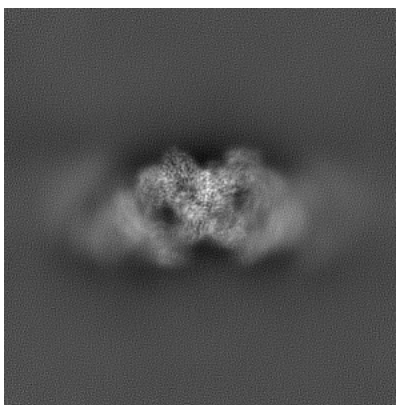

Y

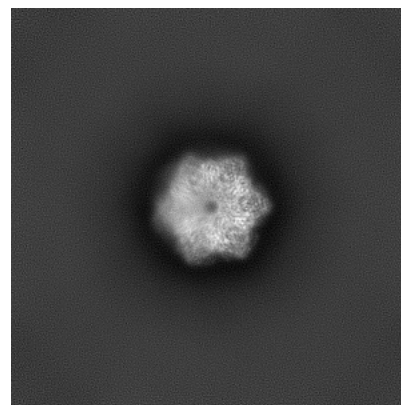

Z

The images above show the map projected in three orthogonal directions.



## 6.2 Central slices [i](#)

### 6.2.1 Primary map

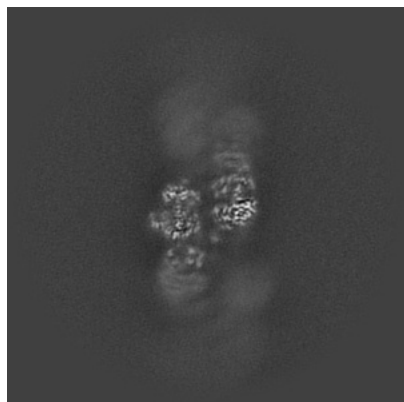

X Index: 200

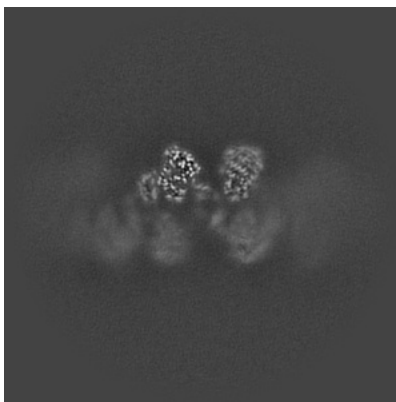

Y Index: 200

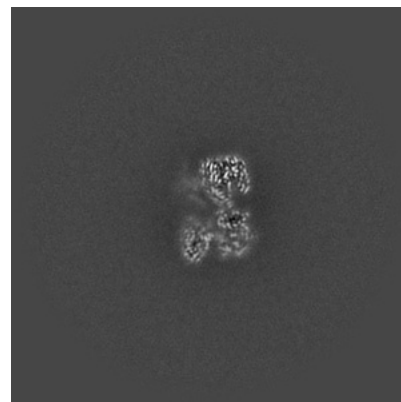

Z Index: 200

### 6.2.2 Raw map



X Index: 200

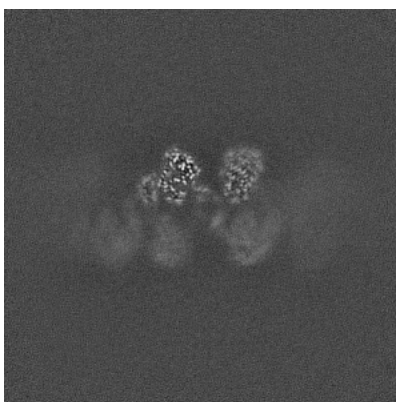

Y Index: 200

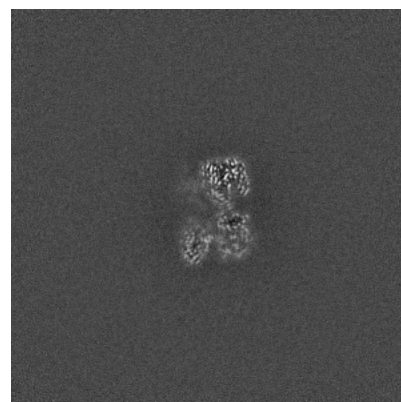

Z Index: 200

The images above show central slices of the map in three orthogonal directions.

## 6.3 Largest variance slices [i](#)

### 6.3.1 Primary map

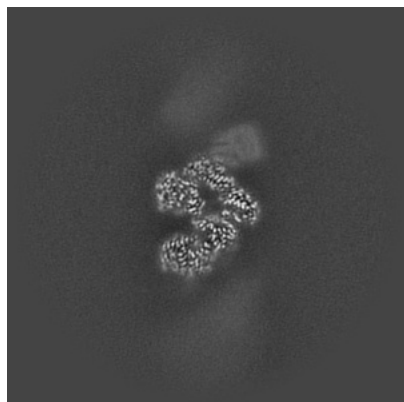

X Index: 225

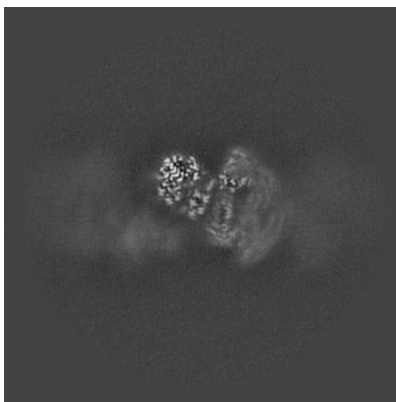

Y Index: 213

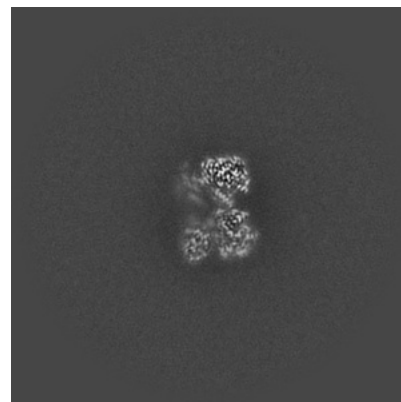

Z Index: 202

### 6.3.2 Raw map

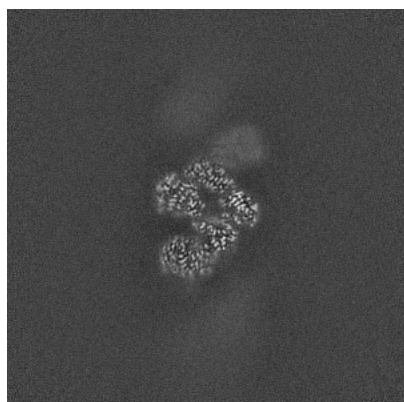

X Index: 224

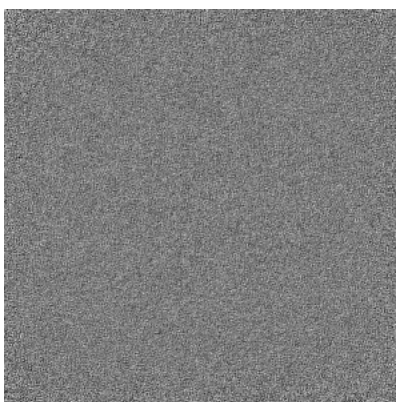

Y Index: 0

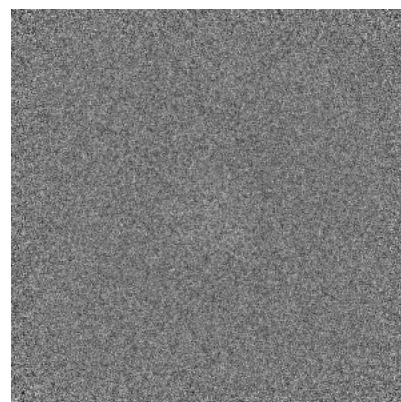

Z Index: 399

The images above show the largest variance slices of the map in three orthogonal directions.

## 6.4 Orthogonal standard-deviation projections (False-color) [i](#)

### 6.4.1 Primary map

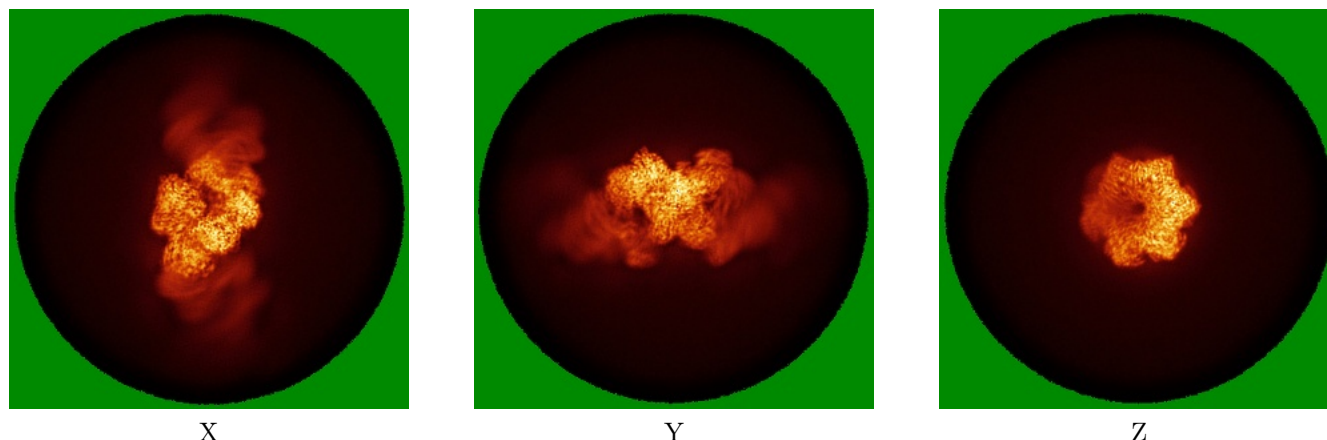

### 6.4.2 Raw map

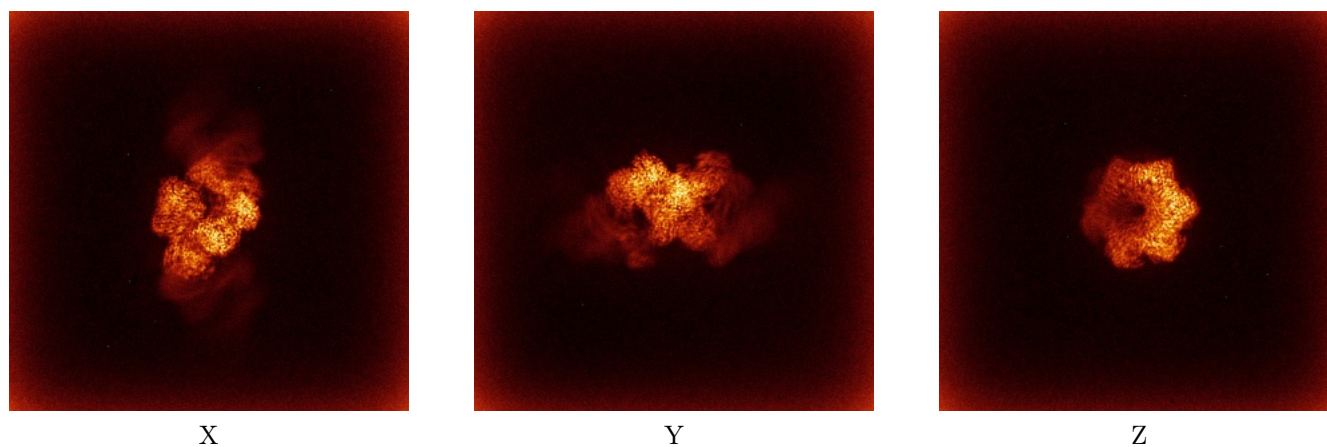

The images above show the map standard deviation projections with false color in three orthogonal directions. Minimum values are shown in green, max in blue, and dark to light orange shades represent small to large values respectively.

## 6.5 Orthogonal surface views [i](#)

### 6.5.1 Primary map

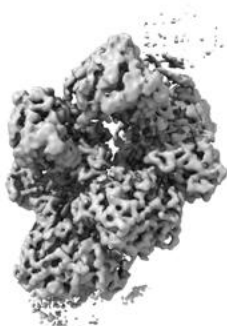

X



Y

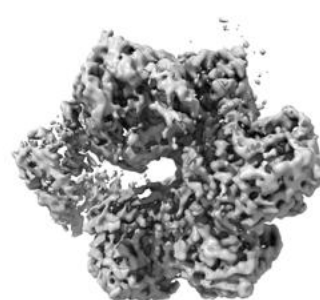

Z

The images above show the 3D surface view of the map at the recommended contour level 0.153. These images, in conjunction with the slice images, may facilitate assessment of whether an appropriate contour level has been provided.

### 6.5.2 Raw map



X

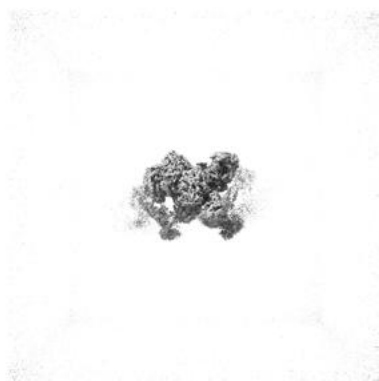

Y

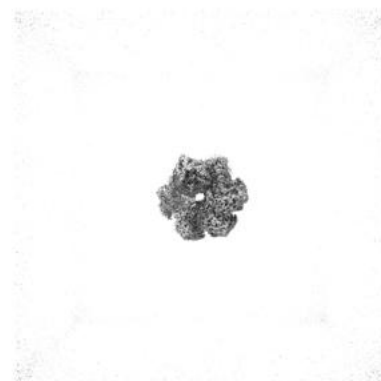

Z

These images show the 3D surface of the raw map. The raw map's contour level was selected so that its surface encloses the same volume as the primary map does at its recommended contour level.

## 6.6 Mask visualisation [i](#)

This section shows the 3D surface view of the primary map at 50% transparency overlaid with the specified mask at 0% transparency

A mask typically either:

- Encompasses the whole structure
- Separates out a domain, a functional unit, a monomer or an area of interest from a larger structure

### 6.6.1 emd\_51188\_msk\_1.map [i](#)

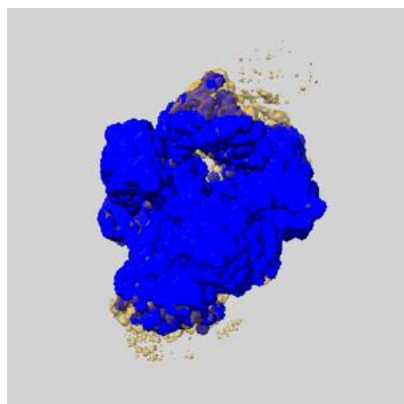

X

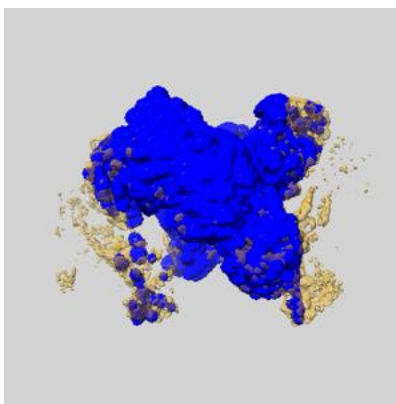

Y

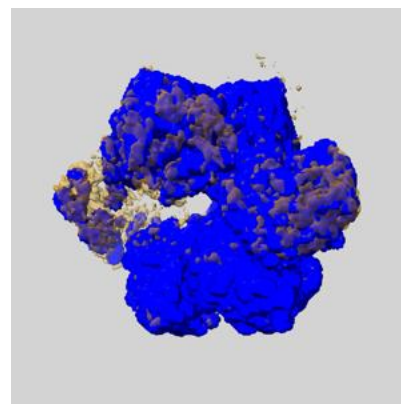

Z

## 7 Map analysis [i](#)

This section contains the results of statistical analysis of the map.

### 7.1 Map-value distribution [i](#)

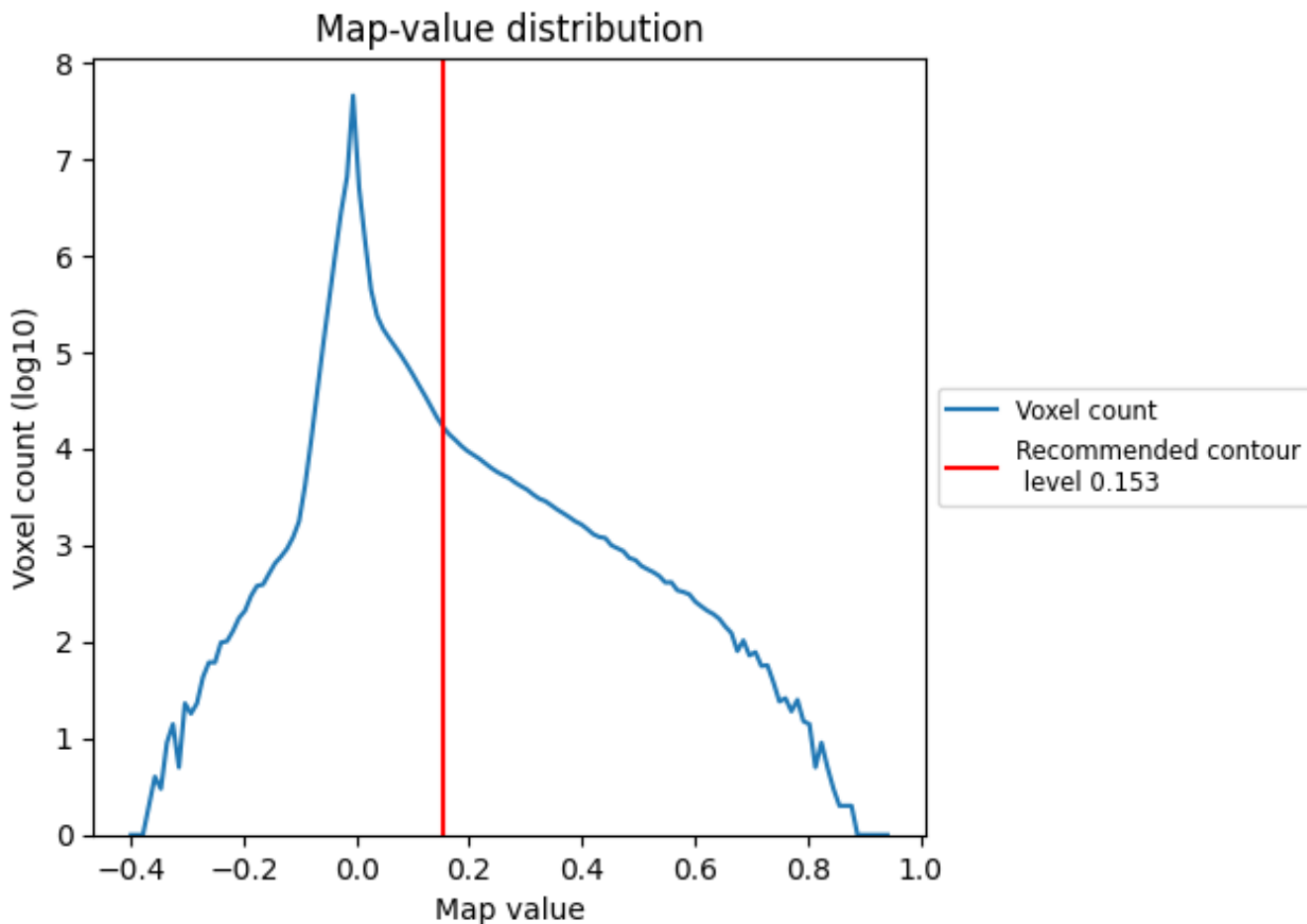

The map-value distribution is plotted in 128 intervals along the x-axis. The y-axis is logarithmic. A spike in this graph at zero usually indicates that the volume has been masked.

## 7.2 Volume estimate [i](#)

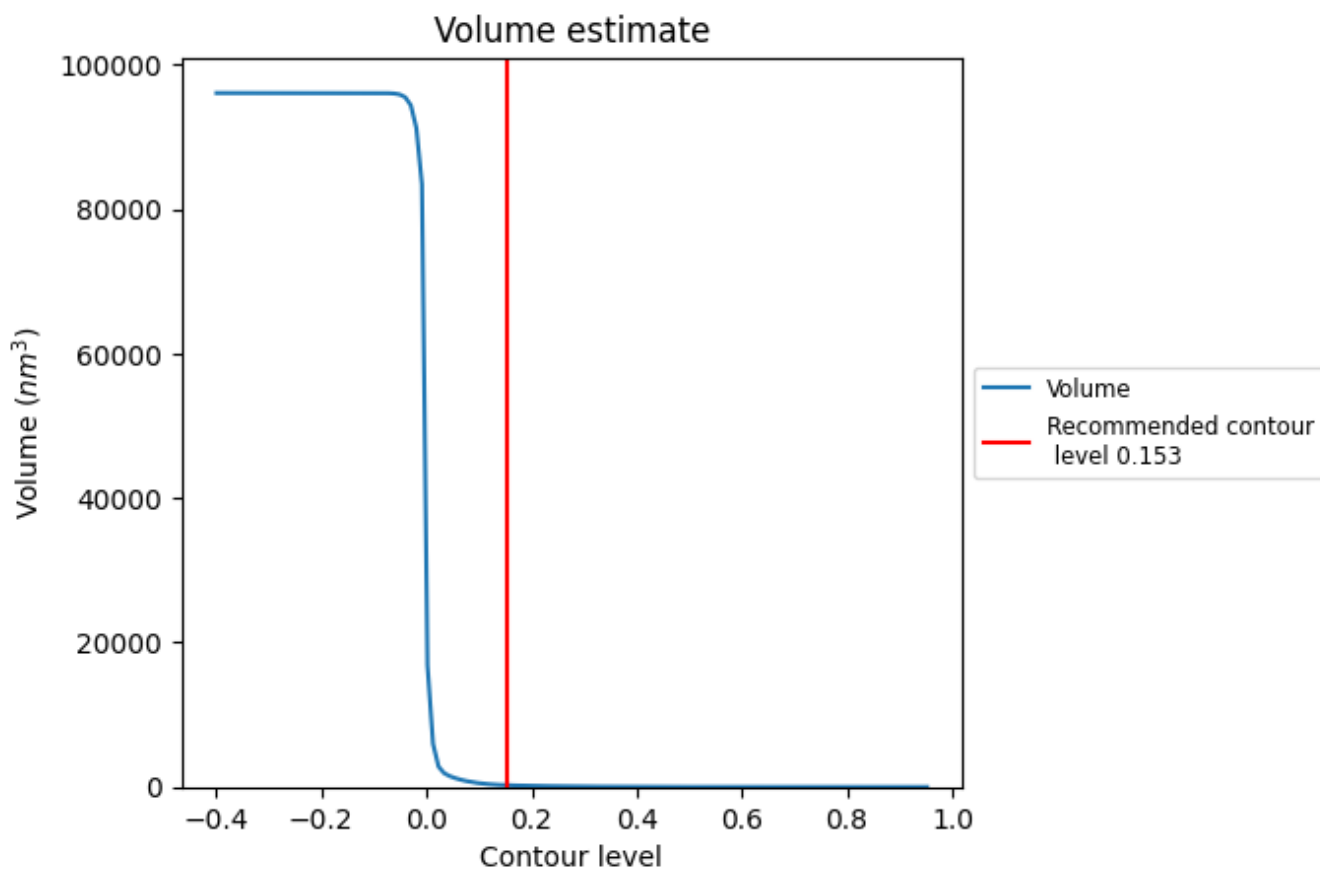

The volume at the recommended contour level is 241 nm<sup>3</sup>; this corresponds to an approximate mass of 218 kDa.

The volume estimate graph shows how the enclosed volume varies with the contour level. The recommended contour level is shown as a vertical line and the intersection between the line and the curve gives the volume of the enclosed surface at the given level.

### 7.3 Rotationally averaged power spectrum i

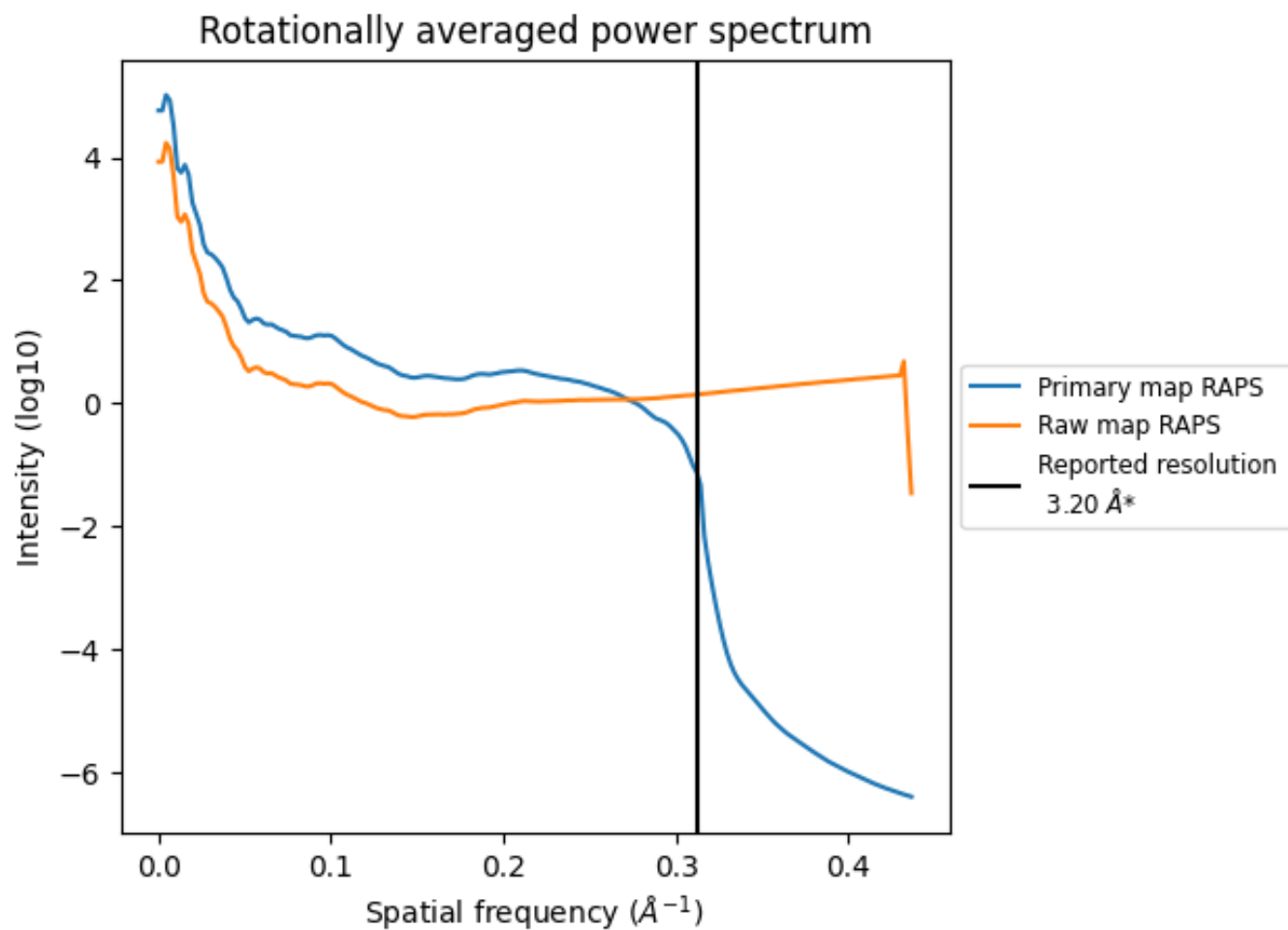

\*Reported resolution corresponds to spatial frequency of 0.312 Å<sup>-1</sup>



## 8 Fourier-Shell correlation [i](#)

Fourier-Shell Correlation (FSC) is the most commonly used method to estimate the resolution of single-particle and subtomogram-averaged maps. The shape of the curve depends on the imposed symmetry, mask and whether or not the two 3D reconstructions used were processed from a common reference. The reported resolution is shown as a black line. A curve is displayed for the half-bit criterion in addition to lines showing the 0.143 gold standard cut-off and 0.5 cut-off.

### 8.1 FSC [i](#)

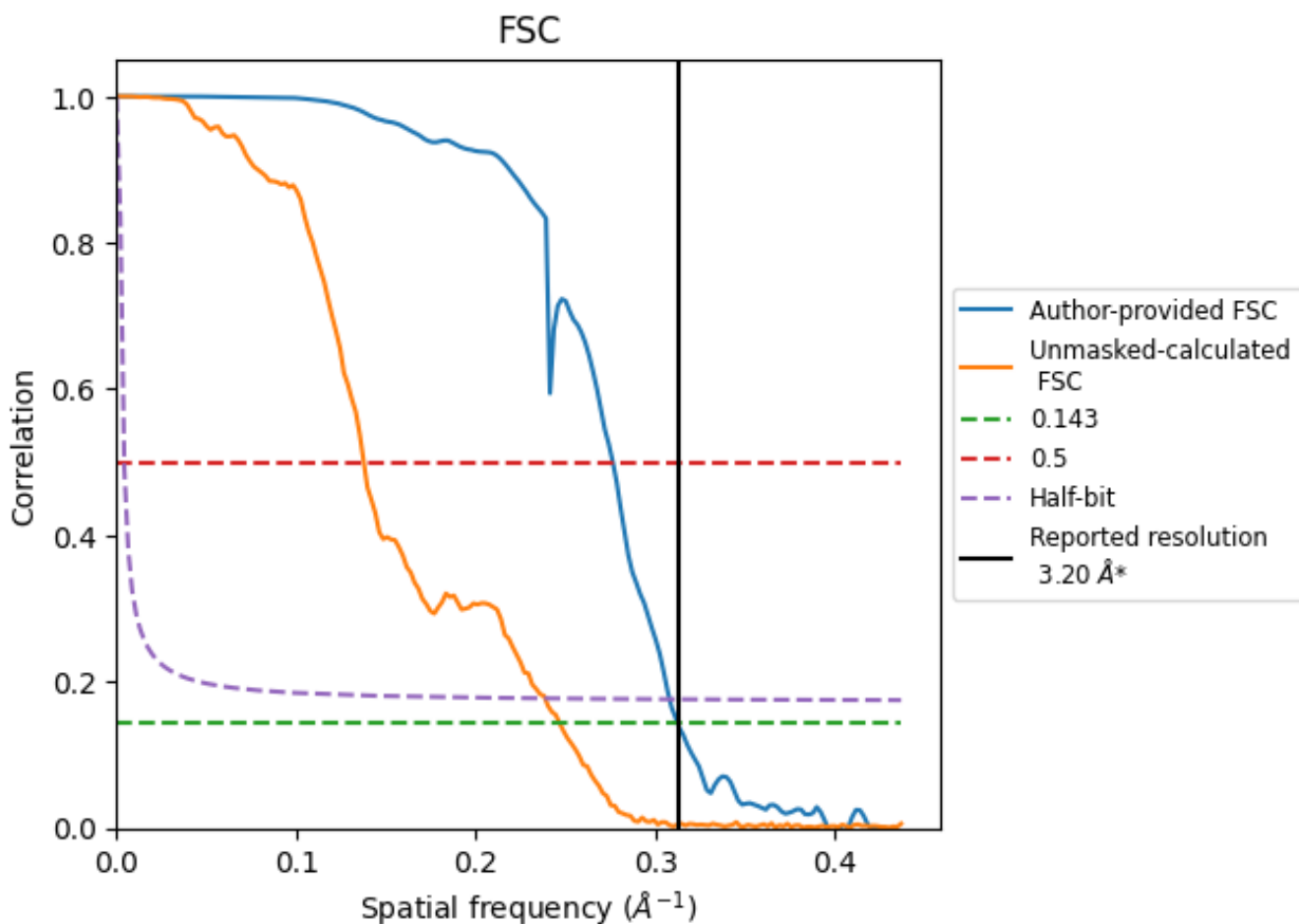

\*Reported resolution corresponds to spatial frequency of 0.312  $\text{\AA}^{-1}$

## 8.2 Resolution estimates [i](#)

Resolution estimate (Å)	Estimation criterion (FSC cut-off)		
	0.143	0.5	Half-bit
Reported by author	3.20	-	-
Author-provided FSC curve	3.20	3.62	3.25
Unmasked-calculated*	4.05	7.27	4.19

\*Resolution estimate based on FSC curve calculated by comparison of deposited half-maps. The value from deposited half-maps intersecting FSC 0.143 CUT-OFF 4.05 differs from the reported value 3.2 by more than 10 %

## 9 Map-model fit [i](#)

This section contains information regarding the fit between EMDB map EMD-51188 and PDB model 9GAT. Per-residue inclusion information can be found in section 3 on page 8.

### 9.1 Map-model overlays

#### 9.1.1 Map-model overlay [i](#)

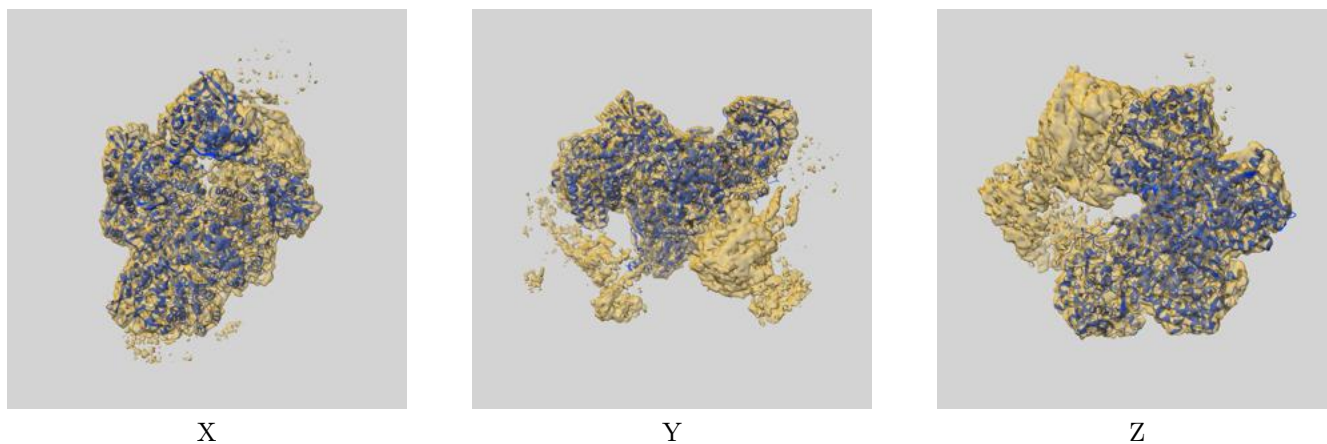

#### 9.1.2 Map-model assembly overlay [i](#)

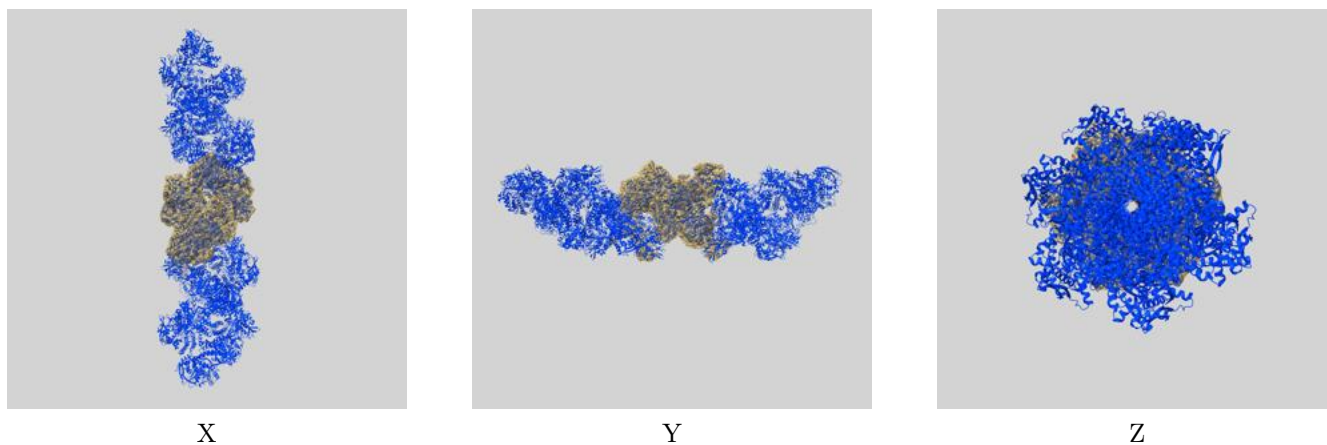

The images above show the 3D surface view of the map at the recommended contour level 0.153 at 50% transparency in yellow overlaid with a ribbon representation of the model coloured in blue. These images allow for the visual assessment of the quality of fit between the atomic model and the map.

## 9.2 Q-score mapped to coordinate model [\(i\)](#)

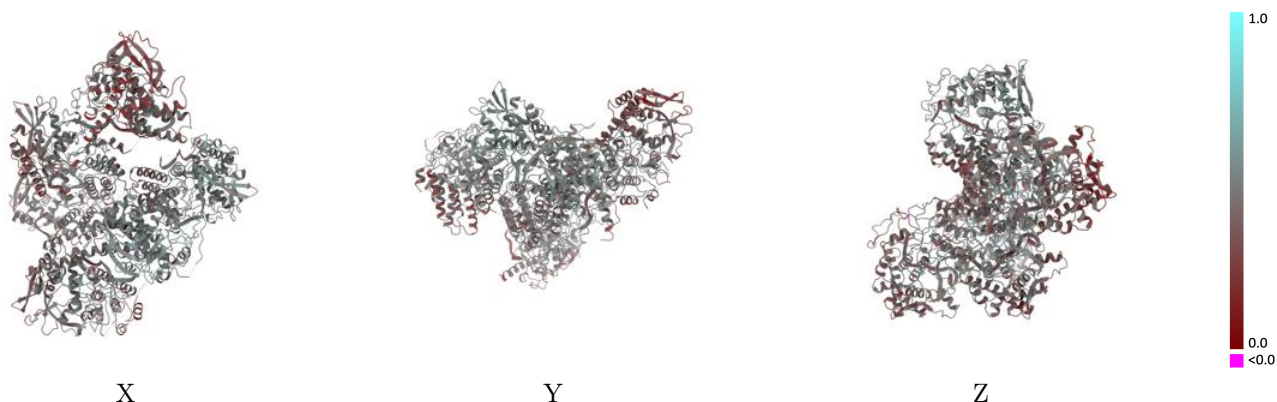

The images above show the model with each residue coloured according to its Q-score. This shows their resolvability in the map with higher Q-score values reflecting better resolvability. Please note: Q-score is calculating the resolvability of atoms, and thus high values are only expected at resolutions at which atoms can be resolved. Low Q-score values may therefore be expected for many entries.

## 9.3 Atom inclusion mapped to coordinate model [\(i\)](#)

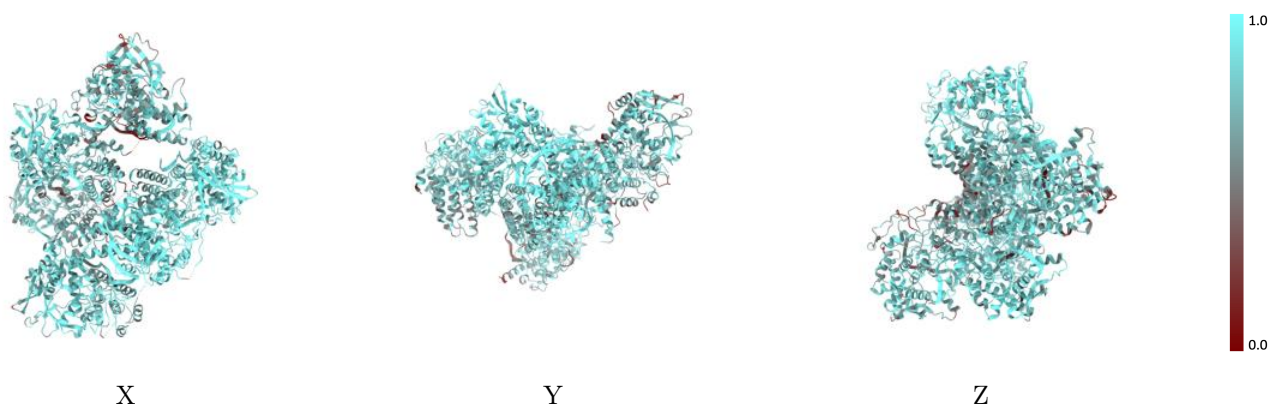

The images above show the model with each residue coloured according to its atom inclusion. This shows to what extent they are inside the map at the recommended contour level (0.153).



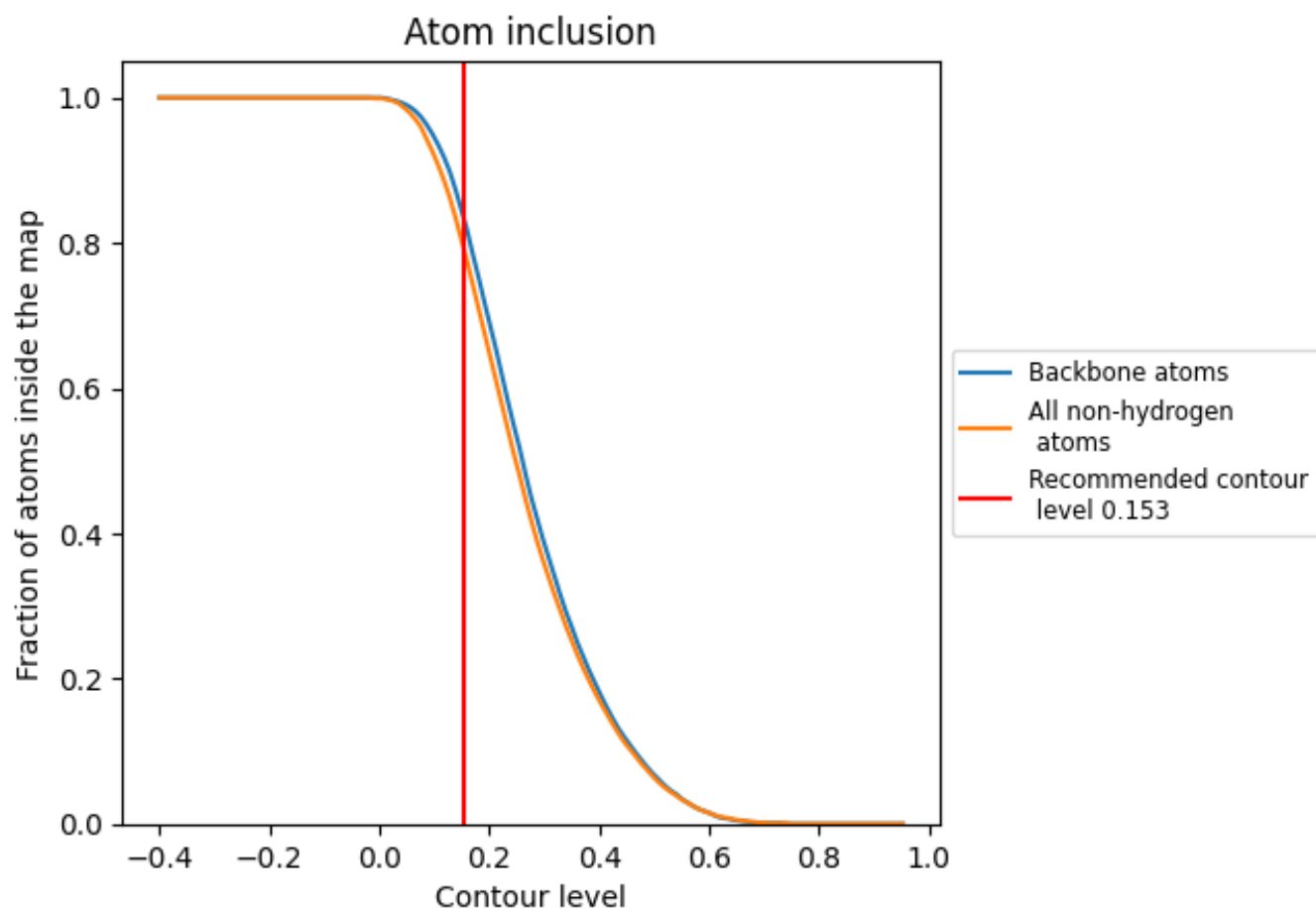































## 9.4 Atom inclusion [i](#)



At the recommended contour level, 84% of all backbone atoms, 80% of all non-hydrogen atoms, are inside the map.

## 9.5 Map-model fit summary

The table lists the average atom inclusion at the recommended contour level (0.153) and Q-score for the entire model and for each chain.

Chain	Atom inclusion	Q-score
All	 0.7950	 0.4370
A	 0.8720	 0.4780
B	 0.8960	 0.4890
C	 0.8090	 0.4300
D	 0.8070	 0.4300
E	 0.8630	 0.4640
F	 0.9170	 0.4850
G	 0.8840	 0.4680
H	 0.9150	 0.4500
I	 0.7460	 0.4060
J	 0.8120	 0.4360
K	 0.7330	 0.3960
L	 0.7440	 0.4370
M	 0.5550	 0.3130
N	 0.7460	 0.3950
O	 0.6650	 0.3810
P	 0.8440	 0.4010

