



Full wwPDB X-ray Structure Validation Report ⓘ

Jun 22, 2024 – 12:06 PM EDT

PDB ID : 6HH1
Title : Structure of c-Kit with allosteric inhibitor 3G8
Authors : Wrasidlo, W.J.; Cheresh, D.A.
Deposited on : 2018-08-24
Resolution : 2.25 Å(reported)

This is a Full wwPDB X-ray Structure Validation Report for a publicly released PDB entry.

We welcome your comments at validation@mail.wwpdb.org

A user guide is available at

<https://www.wwpdb.org/validation/2017/XrayValidationReportHelp>

with specific help available everywhere you see the ⓘ symbol.

The types of validation reports are described at

<http://www.wwpdb.org/validation/2017/FAQs#types>.

The following versions of software and data (see [references ⓘ](#)) were used in the production of this report:

MolProbity : 4.02b-467
Mogul : 2022.3.0, CSD as543be (2022)
Xtriage (Phenix) : 1.20.1
EDS : 2.37.1
buster-report : 1.1.7 (2018)
Percentile statistics : 20191225.v01 (using entries in the PDB archive December 25th 2019)
Refmac : 5.8.0158
CCP4 : 7.0.044 (Gargrove)
Ideal geometry (proteins) : Engh & Huber (2001)
Ideal geometry (DNA, RNA) : Parkinson et al. (1996)
Validation Pipeline (wwPDB-VP) : 2.37.1

1 Overall quality at a glance

The following experimental techniques were used to determine the structure:

X-RAY DIFFRACTION

The reported resolution of this entry is 2.25 Å.

Percentile scores (ranging between 0-100) for global validation metrics of the entry are shown in the following graphic. The table shows the number of entries on which the scores are based.

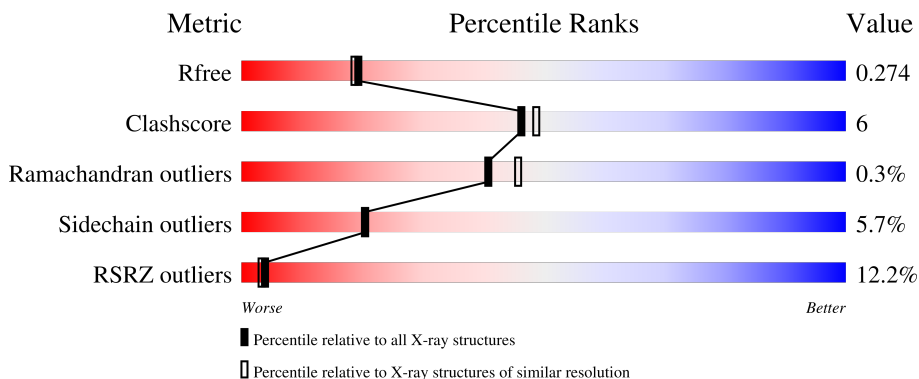

Metric	Whole archive (#Entries)	Similar resolution (#Entries, resolution range(Å))
R_{free}	130704	1377 (2.26-2.26)
Clashscore	141614	1487 (2.26-2.26)
Ramachandran outliers	138981	1449 (2.26-2.26)
Sidechain outliers	138945	1450 (2.26-2.26)
RSRZ outliers	127900	1356 (2.26-2.26)

The table below summarises the geometric issues observed across the polymeric chains and their fit to the electron density. The red, orange, yellow and green segments of the lower bar indicate the fraction of residues that contain outliers for ≥ 3 , 2, 1 and 0 types of geometric quality criteria respectively. A grey segment represents the fraction of residues that are not modelled. The numeric value for each fraction is indicated below the corresponding segment, with a dot representing fractions $\leq 5\%$. The upper red bar (where present) indicates the fraction of residues that have poor fit to the electron density. The numeric value is given above the bar.

Mol	Chain	Length	Quality of chain
1	A	303	

2 Entry composition [i](#)

There are 4 unique types of molecules in this entry. The entry contains 2576 atoms, of which 0 are hydrogens and 0 are deuteriums.

In the tables below, the ZeroOcc column contains the number of atoms modelled with zero occupancy, the AltConf column contains the number of residues with at least one atom in alternate conformation and the Trace column contains the number of residues modelled with at most 2 atoms.

- Molecule 1 is a protein called Mast/stem cell growth factor receptor Kit,Mast/stem cell growth factor receptor Kit.

Mol	Chain	Residues	Atoms					ZeroOcc	AltConf	Trace
			Total	C	N	O	S			
1	A	303	2422	1564	405	433	20	0	4	0

There are 43 discrepancies between the modelled and reference sequences:

Chain	Residue	Modelled	Actual	Comment	Reference
A	694	THR	GLN	conflict	UNP P10721
A	753	SER	GLU	conflict	UNP P10721
A	754	PRO	ASP	conflict	UNP P10721
A	755	ALA	HIS	conflict	UNP P10721
A	756	ILE	ALA	conflict	UNP P10721
A	762	LEU	ALA	conflict	UNP P10721
A	765	ASP	-	linker	UNP P10721
A	766	LEU	-	linker	UNP P10721
A	767	GLU	-	linker	UNP P10721
A	768	ASP	-	linker	UNP P10721
A	769	LEU	-	linker	UNP P10721
A	770	LEU	-	linker	UNP P10721
A	771	SER	-	linker	UNP P10721
A	772	PHE	-	linker	UNP P10721
A	773	SER	-	linker	UNP P10721
A	774	TYR	-	linker	UNP P10721
A	775	GLN	-	linker	UNP P10721
A	776	VAL	-	linker	UNP P10721
A	777	ALA	-	linker	UNP P10721
A	778	LYS	-	linker	UNP P10721
A	779	GLY	-	linker	UNP P10721
A	780	MET	-	linker	UNP P10721
A	781	ALA	-	linker	UNP P10721
A	782	PHE	-	linker	UNP P10721
A	783	LEU	-	linker	UNP P10721
A	784	ALA	-	linker	UNP P10721

Continued on next page...

Continued from previous page...

Chain	Residue	Modelled	Actual	Comment	Reference
A	785	SER	-	linker	UNP P10721
A	786	LYS	-	linker	UNP P10721
A	787	ASN	-	linker	UNP P10721
A	788	CYS	-	linker	UNP P10721
A	789	ILE	-	linker	UNP P10721
A	790	HIS	-	linker	UNP P10721
A	791	ARG	-	linker	UNP P10721
A	792	ASP	-	linker	UNP P10721
A	793	LEU	-	linker	UNP P10721
A	794	ALA	-	linker	UNP P10721
A	795	ALA	-	linker	UNP P10721
A	796	ARG	-	linker	UNP P10721
A	797	ASN	-	linker	UNP P10721
A	798	ILE	-	linker	UNP P10721
A	799	LEU	-	linker	UNP P10721
A	800	LEU	-	linker	UNP P10721
A	801	THR	-	linker	UNP P10721

- Molecule 2 is PHOSPHATE ION (three-letter code: PO4) (formula: O₄P).

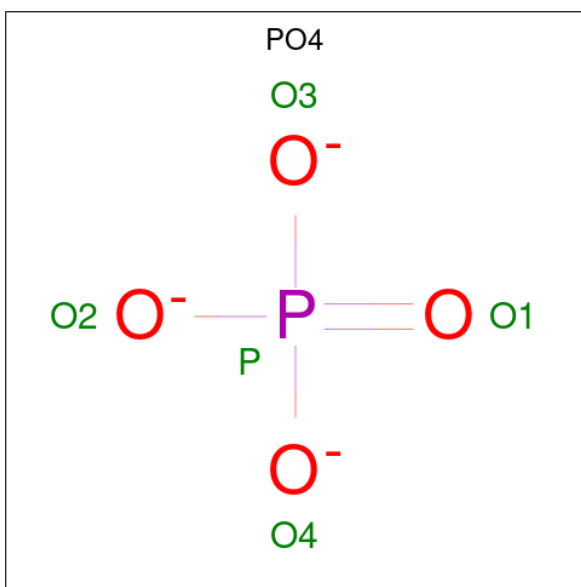

Mol	Chain	Residues	Atoms			ZeroOcc	AltConf
			Total	O	P		
2	A	1	5	4	1	0	0

- Molecule 3 is {N}-(2,3-dimethylphenyl)-5-(4-pyridin-4-yloxyphenyl)-4 {H}-1,2,4-triazol-3-a mine (three-letter code: G4E) (formula: C₂₁H₁₉N₅O).

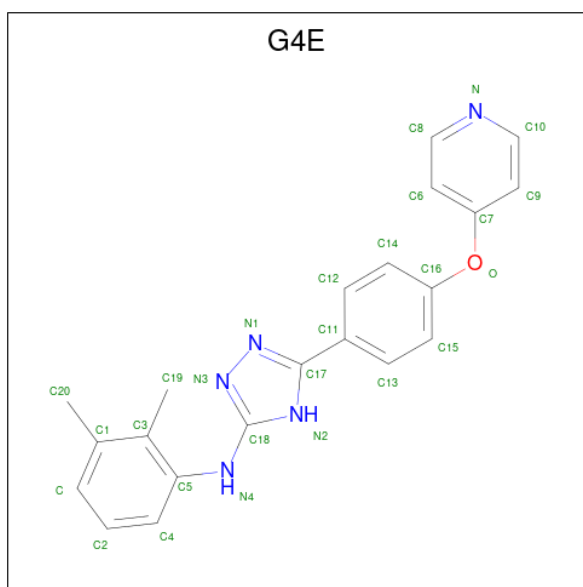

Mol	Chain	Residues	Atoms				ZeroOcc	AltConf
			Total	C	N	O		
3	A	1	27	21	5	1	0	0

- Molecule 4 is water.

Mol	Chain	Residues	Atoms		ZeroOcc	AltConf
			Total	O		
4	A	122	122	122	0	0

3 Residue-property plots [i](#)

These plots are drawn for all protein, RNA, DNA and oligosaccharide chains in the entry. The first graphic for a chain summarises the proportions of the various outlier classes displayed in the second graphic. The second graphic shows the sequence view annotated by issues in geometry and electron density. Residues are color-coded according to the number of geometric quality criteria for which they contain at least one outlier: green = 0, yellow = 1, orange = 2 and red = 3 or more. A red dot above a residue indicates a poor fit to the electron density ($RSRZ > 2$). Stretches of 2 or more consecutive residues without any outlier are shown as a green connector. Residues present in the sample, but not in the model, are shown in grey.

- Molecule 1: Mast/stem cell growth factor receptor Kit, Mast/stem cell growth factor receptor Kit

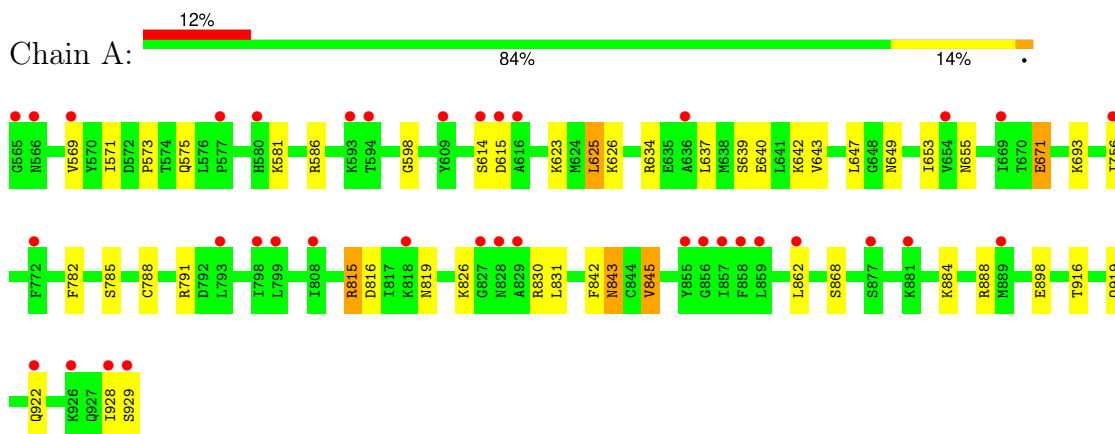

4 Data and refinement statistics i

Property	Value	Source
Space group	P 32 2 1	Depositor
Cell constants a, b, c, α , β , γ	65.61Å 65.61Å 159.00Å 90.00° 90.00° 120.00°	Depositor
Resolution (Å)	25.32 – 2.25 25.30 – 2.25	Depositor EDS
% Data completeness (in resolution range)	94.7 (25.32-2.25) 94.8 (25.30-2.25)	Depositor EDS
R_{merge}	(Not available)	Depositor
R_{sym}	(Not available)	Depositor
$\langle I/\sigma(I) \rangle$ ¹	3.78 (at 2.26Å)	Xtrriage
Refinement program	REFMAC 5.8.0232	Depositor
R, R_{free}	0.204 , 0.273 0.210 , 0.274	Depositor DCC
R_{free} test set	940 reflections (5.07%)	wwPDB-VP
Wilson B-factor (Å ²)	51.6	Xtrriage
Anisotropy	0.070	Xtrriage
Bulk solvent k_{sol} (e/Å ³), B_{sol} (Å ²)	0.35 , 54.4	EDS
L-test for twinning ²	$\langle L \rangle = 0.47$, $\langle L^2 \rangle = 0.29$	Xtrriage
Estimated twinning fraction	0.055 for -h,-k,l	Xtrriage
F_o, F_c correlation	0.96	EDS
Total number of atoms	2576	wwPDB-VP
Average B, all atoms (Å ²)	66.0	wwPDB-VP

Xtrriage's analysis on translational NCS is as follows: *The largest off-origin peak in the Patterson function is 3.64% of the height of the origin peak. No significant pseudotranslation is detected.*

¹Intensities estimated from amplitudes.

²Theoretical values of $\langle |L| \rangle$, $\langle L^2 \rangle$ for acentric reflections are 0.5, 0.333 respectively for untwinned datasets, and 0.375, 0.2 for perfectly twinned datasets.

5 Model quality [i](#)

5.1 Standard geometry [i](#)

Bond lengths and bond angles in the following residue types are not validated in this section: G4E, PO4

The Z score for a bond length (or angle) is the number of standard deviations the observed value is removed from the expected value. A bond length (or angle) with $|Z| > 5$ is considered an outlier worth inspection. RMSZ is the root-mean-square of all Z scores of the bond lengths (or angles).

Mol	Chain	Bond lengths		Bond angles	
		RMSZ	# Z >5	RMSZ	# Z >5
1	A	0.82	0/2492	1.00	1/3368 (0.0%)

There are no bond length outliers.

All (1) bond angle outliers are listed below:

Mol	Chain	Res	Type	Atoms	Z	Observed(°)	Ideal(°)
1	A	888	ARG	NE-CZ-NH1	5.43	123.01	120.30

There are no chirality outliers.

There are no planarity outliers.

5.2 Too-close contacts [i](#)

In the following table, the Non-H and H(model) columns list the number of non-hydrogen atoms and hydrogen atoms in the chain respectively. The H(added) column lists the number of hydrogen atoms added and optimized by MolProbity. The Clashes column lists the number of clashes within the asymmetric unit, whereas Symm-Clashes lists symmetry-related clashes.

Mol	Chain	Non-H	H(model)	H(added)	Clashes	Symm-Clashes
1	A	2422	0	2449	31	0
2	A	5	0	0	0	0
3	A	27	0	0	1	0
4	A	122	0	0	7	2
All	All	2576	0	2449	31	2

The all-atom clashscore is defined as the number of clashes found per 1000 atoms (including hydrogen atoms). The all-atom clashscore for this structure is 6.

All (31) close contacts within the same asymmetric unit are listed below, sorted by their clash

magnitude.

Atom-1	Atom-2	Interatomic distance (Å)	Clash overlap (Å)
1:A:586[B]:ARG:HH21	1:A:586[B]:ARG:HG2	1.21	1.03
1:A:586[B]:ARG:HH21	1:A:586[B]:ARG:CG	1.84	0.90
1:A:671:GLU:OE2	4:A:1101:HOH:O	1.99	0.79
1:A:815:ARG:NH2	4:A:1102:HOH:O	2.19	0.69
1:A:815:ARG:NH1	4:A:1102:HOH:O	2.13	0.67
1:A:586[B]:ARG:CG	1:A:586[B]:ARG:NH2	2.50	0.67
1:A:916:THR:H	1:A:919:GLN:HE21	1.43	0.66
1:A:826:LYS:CE	1:A:831:LEU:HD12	2.30	0.61
1:A:928:ILE:O	1:A:929:SER:OG	2.18	0.59
1:A:816:ASP:OD2	1:A:819:ASN:ND2	2.31	0.56
1:A:571:ILE:HG21	1:A:788[B]:CYS:SG	2.46	0.54
1:A:642:LYS:NZ	4:A:1104:HOH:O	2.33	0.54
1:A:639:SER:O	1:A:643:VAL:HG23	2.07	0.53
1:A:826:LYS:HE2	1:A:831:LEU:HD12	1.92	0.52
1:A:843:ASN:HB2	1:A:845:VAL:HG13	1.93	0.50
1:A:623:LYS:NZ	3:A:1002:G4E:N1	2.59	0.50
1:A:693:LYS:HE2	1:A:756:ILE:CD1	2.42	0.50
1:A:649:ASN:HA	1:A:655:ASN:ND2	2.29	0.48
1:A:782:PHE:O	1:A:785:SER:OG	2.19	0.47
1:A:586[B]:ARG:HG2	1:A:586[B]:ARG:NH2	2.04	0.47
1:A:598:GLY:O	1:A:626:LYS:NZ	2.36	0.46
1:A:826:LYS:HE3	1:A:831:LEU:HD12	1.96	0.46
1:A:640:GLU:HG3	4:A:1135:HOH:O	2.16	0.46
1:A:623:LYS:NZ	1:A:640:GLU:OE1	2.46	0.45
1:A:842:PHE:CZ	1:A:884:LYS:HE3	2.52	0.44
1:A:637:LEU:O	1:A:640:GLU:HB3	2.18	0.43
1:A:625:LEU:HD13	1:A:637:LEU:HD22	2.00	0.43
1:A:647:LEU:HD21	1:A:788[B]:CYS:SG	2.59	0.42
1:A:643:VAL:HG21	4:A:1218:HOH:O	2.19	0.41
1:A:830[B]:ARG:HD3	4:A:1136:HOH:O	2.20	0.41
1:A:573:PRO:C	1:A:575:GLN:H	2.25	0.40

All (2) symmetry-related close contacts are listed below. The label for Atom-2 includes the symmetry operator and encoded unit-cell translations to be applied.

Atom-1	Atom-2	Interatomic distance (Å)	Clash overlap (Å)
4:A:1154:HOH:O	4:A:1163:HOH:O[4_655]	2.07	0.13
4:A:1200:HOH:O	4:A:1207:HOH:O[4_655]	2.10	0.10

5.3 Torsion angles [i](#)

5.3.1 Protein backbone [i](#)

In the following table, the Percentiles column shows the percent Ramachandran outliers of the chain as a percentile score with respect to all X-ray entries followed by that with respect to entries of similar resolution.

The Analysed column shows the number of residues for which the backbone conformation was analysed, and the total number of residues.

Mol	Chain	Analysed	Favoured	Allowed	Outliers	Percentiles
1	A	303/303 (100%)	292 (96%)	10 (3%)	1 (0%)	41 46

All (1) Ramachandran outliers are listed below:

Mol	Chain	Res	Type
1	A	791	ARG

5.3.2 Protein sidechains [i](#)

In the following table, the Percentiles column shows the percent sidechain outliers of the chain as a percentile score with respect to all X-ray entries followed by that with respect to entries of similar resolution.

The Analysed column shows the number of residues for which the sidechain conformation was analysed, and the total number of residues.

Mol	Chain	Analysed	Rotameric	Outliers	Percentiles
1	A	265/261 (102%)	250 (94%)	15 (6%)	20 20

All (15) residues with a non-rotameric sidechain are listed below:

Mol	Chain	Res	Type
1	A	569	VAL
1	A	581	LYS
1	A	614	SER
1	A	615	ASP
1	A	625	LEU
1	A	634	ARG
1	A	653	ILE
1	A	671	GLU
1	A	815	ARG
1	A	843	ASN

Continued on next page...

Continued from previous page...

Mol	Chain	Res	Type
1	A	845	VAL
1	A	862	LEU
1	A	868	SER
1	A	898	GLU
1	A	922	GLN

Sometimes sidechains can be flipped to improve hydrogen bonding and reduce clashes. All (1) such sidechains are listed below:

Mol	Chain	Res	Type
1	A	919	GLN

5.3.3 RNA [i](#)

There are no RNA molecules in this entry.

5.4 Non-standard residues in protein, DNA, RNA chains [i](#)

There are no non-standard protein/DNA/RNA residues in this entry.

5.5 Carbohydrates [i](#)

There are no monosaccharides in this entry.

5.6 Ligand geometry [i](#)

2 ligands are modelled in this entry.

In the following table, the Counts columns list the number of bonds (or angles) for which Mogul statistics could be retrieved, the number of bonds (or angles) that are observed in the model and the number of bonds (or angles) that are defined in the Chemical Component Dictionary. The Link column lists molecule types, if any, to which the group is linked. The Z score for a bond length (or angle) is the number of standard deviations the observed value is removed from the expected value. A bond length (or angle) with $|Z| > 2$ is considered an outlier worth inspection. RMSZ is the root-mean-square of all Z scores of the bond lengths (or angles).

Mol	Type	Chain	Res	Link	Bond lengths			Bond angles		
					Counts	RMSZ	# Z > 2	Counts	RMSZ	# Z > 2
3	G4E	A	1002	-	29,30,30	1.48	2 (6%)	36,41,41	1.37	3 (8%)
2	PO4	A	1001	-	4,4,4	0.55	0	6,6,6	0.55	0

In the following table, the Chirals column lists the number of chiral outliers, the number of chiral centers analysed, the number of these observed in the model and the number defined in the Chemical Component Dictionary. Similar counts are reported in the Torsion and Rings columns. '-' means no outliers of that kind were identified.

Mol	Type	Chain	Res	Link	Chirals	Torsions	Rings
3	G4E	A	1002	-	-	4/10/12/12	0/4/4/4

All (2) bond length outliers are listed below:

Mol	Chain	Res	Type	Atoms	Z	Observed(Å)	Ideal(Å)
3	A	1002	G4E	N1-N3	-5.33	1.27	1.37
3	A	1002	G4E	O-C7	-2.62	1.34	1.39

All (3) bond angle outliers are listed below:

Mol	Chain	Res	Type	Atoms	Z	Observed(°)	Ideal(°)
3	A	1002	G4E	C11-C17-N2	3.68	128.31	123.71
3	A	1002	G4E	C17-N1-N3	3.42	107.58	104.70
3	A	1002	G4E	C13-C11-C17	-2.34	116.94	120.78

There are no chirality outliers.

All (4) torsion outliers are listed below:

Mol	Chain	Res	Type	Atoms
3	A	1002	G4E	C13-C11-C17-N1
3	A	1002	G4E	C12-C11-C17-N1
3	A	1002	G4E	C13-C11-C17-N2
3	A	1002	G4E	C12-C11-C17-N2

There are no ring outliers.

1 monomer is involved in 1 short contact:

Mol	Chain	Res	Type	Clashes	Symm-Clashes
3	A	1002	G4E	1	0

The following is a two-dimensional graphical depiction of Mogul quality analysis of bond lengths, bond angles, torsion angles, and ring geometry for all instances of the Ligand of Interest. In addition, ligands with molecular weight > 250 and outliers as shown on the validation Tables will also be included. For torsion angles, if less than 5% of the Mogul distribution of torsion angles is within 10 degrees of the torsion angle in question, then that torsion angle is considered an outlier. Any bond that is central to one or more torsion angles identified as an outlier by Mogul will be highlighted in the graph. For rings, the root-mean-square deviation (RMSD) between the ring

in question and similar rings identified by Mogul is calculated over all ring torsion angles. If the average RMSD is greater than 60 degrees and the minimal RMSD between the ring in question and any Mogul-identified rings is also greater than 60 degrees, then that ring is considered an outlier. The outliers are highlighted in purple. The color gray indicates Mogul did not find sufficient equivalents in the CSD to analyse the geometry.

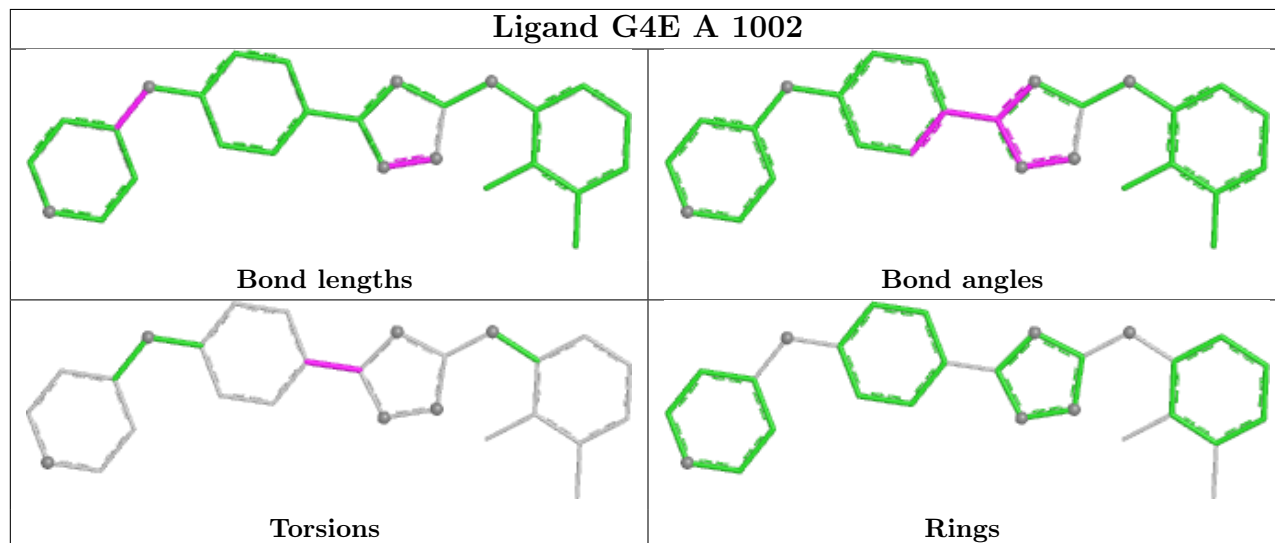

5.7 Other polymers [i](#)

There are no such residues in this entry.

5.8 Polymer linkage issues [i](#)

The following chains have linkage breaks:

Mol	Chain	Number of breaks
1	A	1

All chain breaks are listed below:

Model	Chain	Residue-1	Atom-1	Residue-2	Atom-2	Distance (Å)
1	A	756:ILE	C	761:GLU	N	25.33

6 Fit of model and data

6.1 Protein, DNA and RNA chains

In the following table, the column labelled ‘#RSRZ> 2’ contains the number (and percentage) of RSRZ outliers, followed by percent RSRZ outliers for the chain as percentile scores relative to all X-ray entries and entries of similar resolution. The OWAB column contains the minimum, median, 95th percentile and maximum values of the occupancy-weighted average B-factor per residue. The column labelled ‘Q< 0.9’ lists the number of (and percentage) of residues with an average occupancy less than 0.9.

Mol	Chain	Analysed	<RSRZ>	#RSRZ>2	OWAB(Å ²)	Q<0.9
1	A	303/303 (100%)	0.59	37 (12%) 4 3	42, 65, 94, 115	0

All (37) RSRZ outliers are listed below:

Mol	Chain	Res	Type	RSRZ
1	A	928	ILE	5.3
1	A	828	ASN	5.1
1	A	929	SER	4.8
1	A	829	ALA	4.6
1	A	565	GLY	4.4
1	A	614	SER	4.2
1	A	577	PRO	3.9
1	A	859	LEU	3.8
1	A	857	ILE	3.4
1	A	615	ASP	3.0
1	A	793	LEU	2.9
1	A	669	ILE	2.9
1	A	580	HIS	2.8
1	A	858	PHE	2.8
1	A	594	THR	2.8
1	A	889	MET	2.7
1	A	616	ALA	2.7
1	A	926	LYS	2.7
1	A	566	ASN	2.7
1	A	881	LYS	2.6
1	A	855	TYR	2.6
1	A	636	ALA	2.5
1	A	862	LEU	2.4
1	A	756	ILE	2.3
1	A	799	LEU	2.3
1	A	818	LYS	2.3
1	A	877	SER	2.2

Continued on next page...

Continued from previous page...

Mol	Chain	Res	Type	RSRZ
1	A	808	ILE	2.2
1	A	827	GLY	2.2
1	A	798	ILE	2.1
1	A	654	VAL	2.1
1	A	922	GLN	2.1
1	A	609	TYR	2.1
1	A	569	VAL	2.1
1	A	856	GLY	2.0
1	A	593	LYS	2.0
1	A	772	PHE	2.0

6.2 Non-standard residues in protein, DNA, RNA chains [i](#)

There are no non-standard protein/DNA/RNA residues in this entry.

6.3 Carbohydrates [i](#)

There are no monosaccharides in this entry.

6.4 Ligands [i](#)

In the following table, the Atoms column lists the number of modelled atoms in the group and the number defined in the chemical component dictionary. The B-factors column lists the minimum, median, 95th percentile and maximum values of B factors of atoms in the group. The column labelled 'Q< 0.9' lists the number of atoms with occupancy less than 0.9.

Mol	Type	Chain	Res	Atoms	RSCC	RSR	B-factors(\AA^2)	Q<0.9
3	G4E	A	1002	27/27	0.96	0.23	46,51,59,64	0
2	PO4	A	1001	5/5	0.99	0.08	77,83,84,86	0

The following is a graphical depiction of the model fit to experimental electron density of all instances of the Ligand of Interest. In addition, ligands with molecular weight > 250 and outliers as shown on the geometry validation Tables will also be included. Each fit is shown from different orientation to approximate a three-dimensional view.

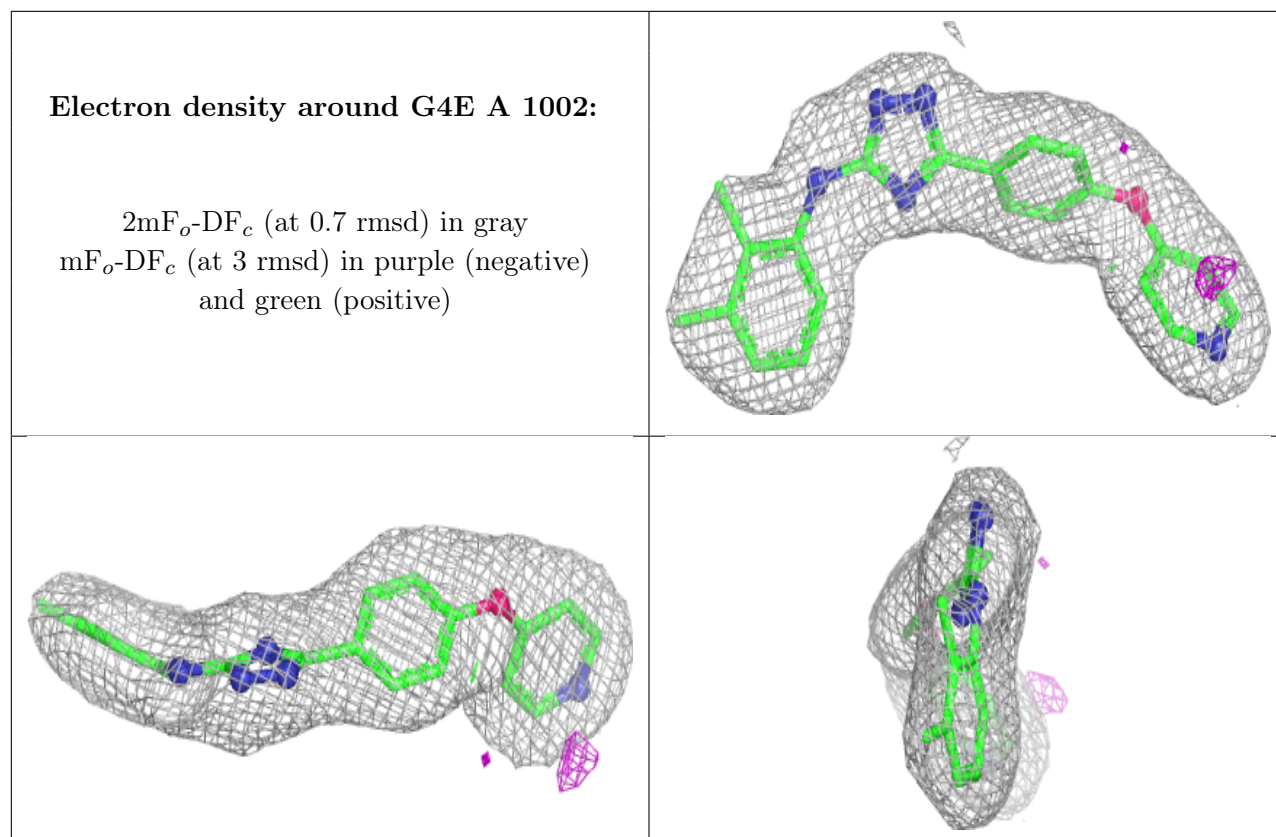

6.5 Other polymers [i](#)

There are no such residues in this entry.