



wwPDB EM Validation Summary Report ⓘ

Mar 13, 2024 – 01:48 PM JST

PDB ID : 3JCP
EMDB ID : EMD-6575
Title : Structure of yeast 26S proteasome in M2 state derived from Titan dataset
Authors : Luan, B.; Huang, X.L.; Wu, J.P.; Shi, Y.G.; Wang, F.
Deposited on : 2016-01-06
Resolution : 4.60 Å (reported)
Based on initial model : 4CR2

This is a wwPDB EM Validation Summary Report for a publicly released PDB entry.

We welcome your comments at validation@mail.wwpdb.org

A user guide is available at

<https://www.wwpdb.org/validation/2017/EMValidationReportHelp>

with specific help available everywhere you see the ⓘ symbol.

The types of validation reports are described at

<http://www.wwpdb.org/validation/2017/FAQs#types>.

The following versions of software and data (see [references ⓘ](#)) were used in the production of this report:

EMDB validation analysis : 0.0.1.dev70
MolProbity : 4.02b-467
Percentile statistics : 20191225.v01 (using entries in the PDB archive December 25th 2019)
MapQ : 1.9.13
Ideal geometry (proteins) : Engh & Huber (2001)
Ideal geometry (DNA, RNA) : Parkinson et al. (1996)
Validation Pipeline (wwPDB-VP) : 2.36

1 Overall quality at a glance i

The following experimental techniques were used to determine the structure:
ELECTRON MICROSCOPY

The reported resolution of this entry is 4.60 Å.

Percentile scores (ranging between 0-100) for global validation metrics of the entry are shown in the following graphic. The table shows the number of entries on which the scores are based.

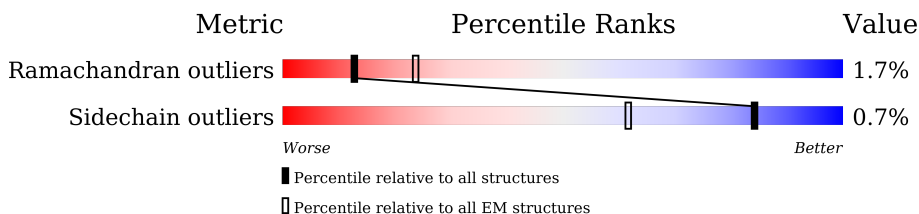

Metric	Whole archive (#Entries)	EM structures (#Entries)
Ramachandran outliers	154571	4023
Sidechain outliers	154315	3826

The table below summarises the geometric issues observed across the polymeric chains and their fit to the map. The red, orange, yellow and green segments of the bar indicate the fraction of residues that contain outliers for ≥ 3 , 2, 1 and 0 types of geometric quality criteria respectively. A grey segment represents the fraction of residues that are not modelled. The numeric value for each fraction is indicated below the corresponding segment, with a dot representing fractions $\leq 5\%$. The upper red bar (where present) indicates the fraction of residues that have poor fit to the EM map (all-atom inclusion $< 40\%$). The numeric value is given above the bar.

Mol	Chain	Length	Quality of chain
1	1	241	 6% 92% 8%
1	8	241	 5% 92% 8%
2	2	266	 87% 12%
2	9	266	 87% 12%
3	3	215	 7% 94% 5%
3	h	215	 7% 94% 5%
4	4	261	 85% 15%
4	i	261	 85% 15%
5	5	205	 7% 99%

Continued on next page...

Continued from previous page...

Mol	Chain	Length	Quality of chain
5	j	205	5% 99%
6	6	198	8% 99%
6	k	198	8% 99%
7	7	287	74% 26%
7	l	287	74% 26%
8	A	252	9% 96%
8	a	252	8% 96%
9	B	250	8% 100%
9	b	250	10% 100%
10	C	258	7% 95% 5%
10	c	258	14% 95% 5%
11	D	254	8% 94% 5%
11	d	254	8% 94% 5%
12	E	260	10% 93% 7%
12	e	260	10% 93% 7%
13	F	234	5% 100%
13	f	234	6% 100%
14	G	288	5% 83% 15%
14	g	288	5% 84% 15%
15	H	467	22% 76% 18%
16	I	437	24% 77% 19%
17	J	405	31% 90% 8%
18	K	428	25% 79% 16%
19	L	437	20% 79% 18%
20	M	434	25% 81% 18%

Continued on next page...

Continued from previous page...

Mol	Chain	Length	Quality of chain
21	N	945	
22	O	393	
23	P	445	
24	Q	434	
25	R	429	
26	S	523	
27	T	274	
28	U	338	
29	V	306	
30	W	268	
31	X	156	
32	Y	89	
33	Z	993	

2 Entry composition [i](#)

There are 33 unique types of molecules in this entry. The entry contains 104170 atoms, of which 0 are hydrogens and 0 are deuteriums.

In the tables below, the AltConf column contains the number of residues with at least one atom in alternate conformation and the Trace column contains the number of residues modelled with at most 2 atoms.

- Molecule 1 is a protein called Proteasome subunit beta type-6.

Mol	Chain	Residues	Atoms					AltConf	Trace
			Total	C	N	O	S		
1	1	222	Total	C	N	O	S	0	0
			1757	1115	303	335	4		
1	8	222	Total	C	N	O	S	0	0
			1757	1115	303	335	4		

- Molecule 2 is a protein called Proteasome subunit beta type-7.

Mol	Chain	Residues	Atoms					AltConf	Trace
			Total	C	N	O	S		
2	2	233	Total	C	N	O	S	0	0
			1824	1154	312	351	7		
2	9	233	Total	C	N	O	S	0	0
			1824	1154	312	351	7		

- Molecule 3 is a protein called Proteasome subunit beta type-1.

Mol	Chain	Residues	Atoms					AltConf	Trace
			Total	C	N	O	S		
3	3	205	Total	C	N	O	S	0	0
			1573	995	260	311	7		
3	h	205	Total	C	N	O	S	0	0
			1574	995	261	311	7		

- Molecule 4 is a protein called Proteasome subunit beta type-2.

Mol	Chain	Residues	Atoms					AltConf	Trace
			Total	C	N	O	S		
4	4	222	Total	C	N	O	S	0	0
			1684	1061	293	323	7		
4	i	222	Total	C	N	O	S	0	0
			1684	1061	293	323	7		

- Molecule 5 is a protein called Proteasome subunit beta type-3.

Mol	Chain	Residues	Atoms					AltConf	Trace
5	5	204	Total	C	N	O	S	0	0
			1581	1010	258	305	8		
5	j	204	Total	C	N	O	S	0	0
			1578	1009	257	304	8		

- Molecule 6 is a protein called Proteasome subunit beta type-4.

Mol	Chain	Residues	Atoms					AltConf	Trace
6	6	198	Total	C	N	O	S	0	0
			1585	1005	269	305	6		
6	k	198	Total	C	N	O	S	0	0
			1585	1005	269	305	6		

- Molecule 7 is a protein called Proteasome subunit beta type-5.

Mol	Chain	Residues	Atoms					AltConf	Trace
7	7	212	Total	C	N	O	S	0	0
			1644	1045	280	312	7		
7	l	212	Total	C	N	O	S	0	0
			1644	1045	280	312	7		

- Molecule 8 is a protein called Proteasome subunit alpha type-1.

Mol	Chain	Residues	Atoms					AltConf	Trace
8	A	243	Total	C	N	O	S	0	0
			1921	1221	322	370	8		
8	a	243	Total	C	N	O	S	0	0
			1921	1221	322	370	8		

- Molecule 9 is a protein called Proteasome subunit alpha type-2.

Mol	Chain	Residues	Atoms					AltConf	Trace
9	B	250	Total	C	N	O	S	0	0
			1915	1219	315	377	4		
9	b	250	Total	C	N	O	S	0	0
			1915	1219	315	377	4		

- Molecule 10 is a protein called Proteasome subunit alpha type-3.

Mol	Chain	Residues	Atoms					AltConf	Trace
10	C	244	Total	C	N	O	S	0	0
			1904	1201	321	379	3		

Continued on next page...

Continued from previous page...

Mol	Chain	Residues	Atoms					AltConf	Trace
10	c	244	Total	C	N	O	S	0	0
			1904	1201	321	379	3		

- Molecule 11 is a protein called Proteasome subunit alpha type-4.

Mol	Chain	Residues	Atoms					AltConf	Trace
11	D	241	Total	C	N	O	S	0	0
			1890	1181	331	374	4		
11	d	241	Total	C	N	O	S	0	0
			1890	1181	331	374	4		

- Molecule 12 is a protein called Proteasome subunit alpha type-5.

Mol	Chain	Residues	Atoms					AltConf	Trace
12	E	242	Total	C	N	O	S	0	0
			1861	1162	314	378	7		
12	e	242	Total	C	N	O	S	0	0
			1861	1162	314	378	7		

- Molecule 13 is a protein called Proteasome subunit alpha type-6.

Mol	Chain	Residues	Atoms					AltConf	Trace
13	F	233	Total	C	N	O	S	0	0
			1795	1129	312	350	4		
13	f	233	Total	C	N	O	S	0	0
			1795	1129	312	350	4		

- Molecule 14 is a protein called Probable proteasome subunit alpha type-7.

Mol	Chain	Residues	Atoms					AltConf	Trace
14	G	244	Total	C	N	O	S	0	0
			1896	1205	330	357	4		
14	g	244	Total	C	N	O	S	0	0
			1896	1205	330	357	4		

- Molecule 15 is a protein called 26S protease regulatory subunit 7 homolog.

Mol	Chain	Residues	Atoms					AltConf	Trace
15	H	381	Total	C	N	O	S	0	0
			2877	1806	519	537	15		

- Molecule 16 is a protein called 26S protease regulatory subunit 4 homolog.

Mol	Chain	Residues	Atoms					AltConf	Trace
			Total	C	N	O	S		
16	I	354	2652	1655	453	531	13	0	0

- Molecule 17 is a protein called 26S protease regulatory subunit 8 homolog.

Mol	Chain	Residues	Atoms					AltConf	Trace
			Total	C	N	O	S		
17	J	373	2914	1824	526	547	17	0	0

- Molecule 18 is a protein called 26S protease regulatory subunit 6B homolog.

Mol	Chain	Residues	Atoms					AltConf	Trace
			Total	C	N	O	S		
18	K	361	2835	1777	506	542	10	0	0

- Molecule 19 is a protein called 26S protease subunit RPT4.

Mol	Chain	Residues	Atoms					AltConf	Trace
			Total	C	N	O	S		
19	L	358	2829	1782	501	534	12	0	0

- Molecule 20 is a protein called 26S protease regulatory subunit 6A.

Mol	Chain	Residues	Atoms					AltConf	Trace
			Total	C	N	O	S		
20	M	357	2754	1723	473	548	10	0	0

- Molecule 21 is a protein called 26S proteasome regulatory subunit RPN2.

Mol	Chain	Residues	Atoms					AltConf	Trace
			Total	C	N	O	S		
21	N	850	6570	4178	1100	1264	28	0	0

- Molecule 22 is a protein called 26S proteasome regulatory subunit RPN9.

Mol	Chain	Residues	Atoms					AltConf	Trace
			Total	C	N	O	S		
22	O	376	2912	1867	481	557	7	0	0

- Molecule 23 is a protein called 26S proteasome regulatory subunit RPN5.

Mol	Chain	Residues	Atoms					AltConf	Trace
			Total	C	N	O	S		
23	P	431	3470	2210	585	667	8	0	0

- Molecule 24 is a protein called 26S proteasome regulatory subunit RPN6.

Mol	Chain	Residues	Atoms					AltConf	Trace
			Total	C	N	O	S		
24	Q	431	3469	2203	574	676	16	0	0

- Molecule 25 is a protein called 26S proteasome regulatory subunit RPN7.

Mol	Chain	Residues	Atoms					AltConf	Trace
			Total	C	N	O	S		
25	R	400	3187	2028	525	624	10	0	0

- Molecule 26 is a protein called 26S proteasome regulatory subunit RPN3.

Mol	Chain	Residues	Atoms					AltConf	Trace
			Total	C	N	O	S		
26	S	439	3384	2155	575	637	17	0	0

- Molecule 27 is a protein called 26S proteasome regulatory subunit RPN12.

Mol	Chain	Residues	Atoms					AltConf	Trace
			Total	C	N	O	S		
27	T	267	2201	1410	350	435	6	0	0

- Molecule 28 is a protein called 26S proteasome regulatory subunit RPN8.

Mol	Chain	Residues	Atoms					AltConf	Trace
			Total	C	N	O	S		
28	U	254	2049	1304	350	389	6	0	0

- Molecule 29 is a protein called Ubiquitin carboxyl-terminal hydrolase RPN11.

Mol	Chain	Residues	Atoms					AltConf	Trace
			Total	C	N	O	S		
29	V	245	1912	1206	322	371	13	0	0

- Molecule 30 is a protein called 26S proteasome regulatory subunit RPN10.

Mol	Chain	Residues	Atoms					AltConf	Trace
			Total	C	N	O	S		
30	W	197	1534	962	269	300	3	0	0

- Molecule 31 is a protein called 26S proteasome regulatory subunit RPN13.

Mol	Chain	Residues	Atoms					AltConf	Trace
			Total	C	N	O	S		
31	X	127	1032	664	169	195	4	0	0

- Molecule 32 is a protein called 26S proteasome complex subunit SEM1.

Mol	Chain	Residues	Atoms				AltConf	Trace
			Total	C	N	O		
32	Y	34	243	146	45	52	0	0

- Molecule 33 is a protein called 26S proteasome regulatory subunit RPN1.

Mol	Chain	Residues	Atoms					AltConf	Trace
			Total	C	N	O	S		
33	Z	746	5688	3616	940	1106	26	0	0

3 Residue-property plots [i](#)

These plots are drawn for all protein, RNA, DNA and oligosaccharide chains in the entry. The first graphic for a chain summarises the proportions of the various outlier classes displayed in the second graphic. The second graphic shows the sequence view annotated by issues in geometry and atom inclusion in map density. Residues are color-coded according to the number of geometric quality criteria for which they contain at least one outlier: green = 0, yellow = 1, orange = 2 and red = 3 or more. A red diamond above a residue indicates a poor fit to the EM map for this residue (all-atom inclusion < 40%). Stretches of 2 or more consecutive residues without any outlier are shown as a green connector. Residues present in the sample, but not in the model, are shown in grey.

- Molecule 1: Proteasome subunit beta type-6

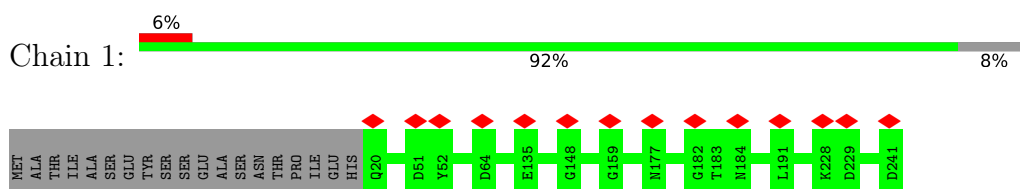

- Molecule 1: Proteasome subunit beta type-6

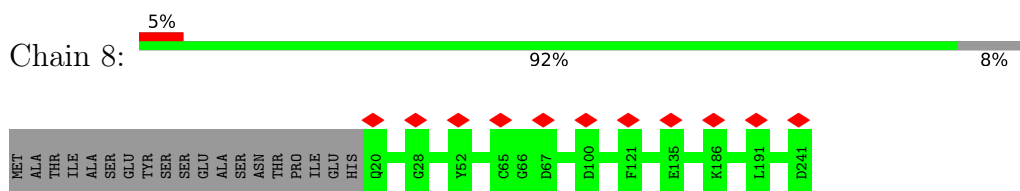

- Molecule 2: Proteasome subunit beta type-7

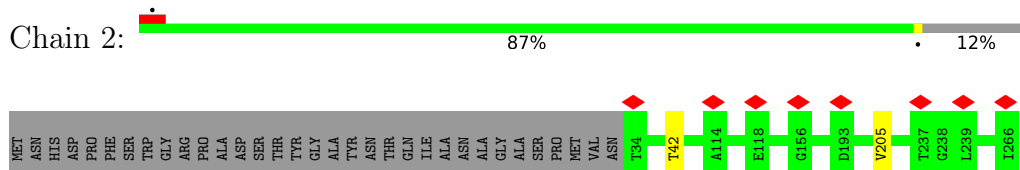

- Molecule 2: Proteasome subunit beta type-7

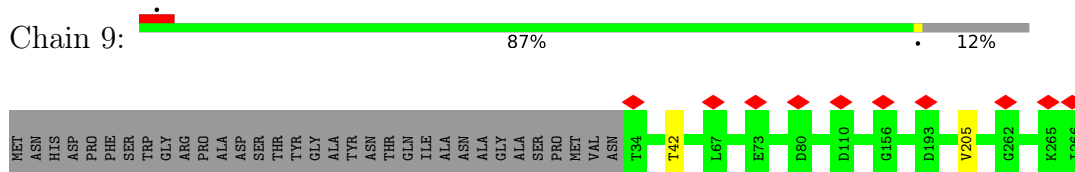

- Molecule 3: Proteasome subunit beta type-1

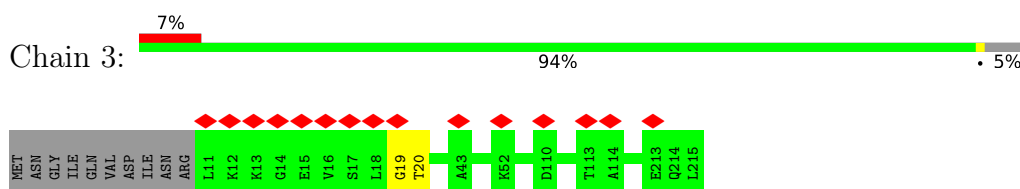

- Molecule 3: Proteasome subunit beta type-1

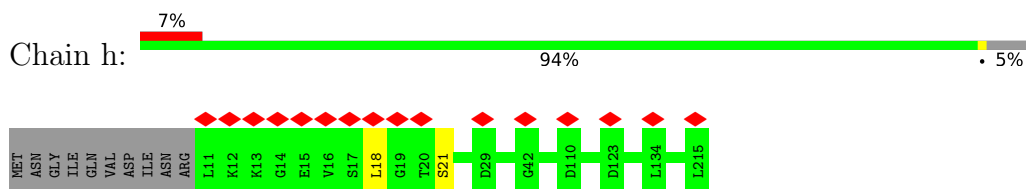

- Molecule 4: Proteasome subunit beta type-2

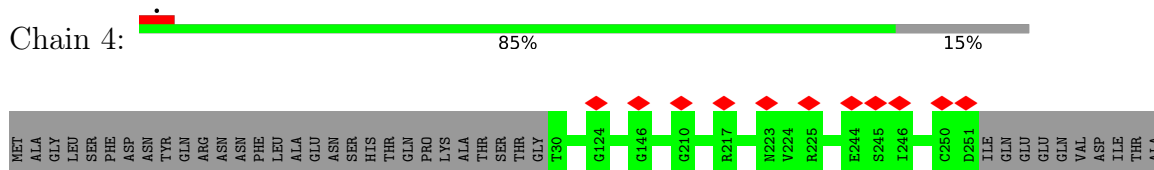

- Molecule 4: Proteasome subunit beta type-2

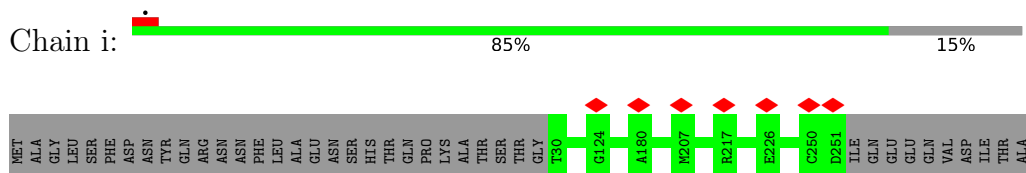

- Molecule 5: Proteasome subunit beta type-3

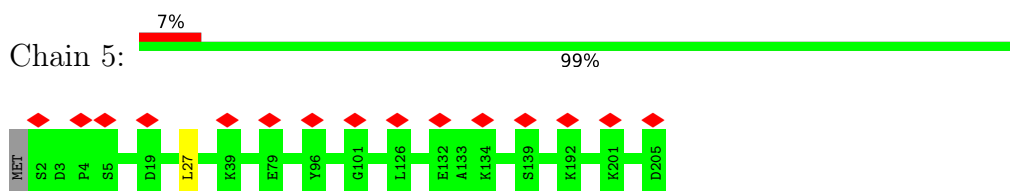

- Molecule 5: Proteasome subunit beta type-3

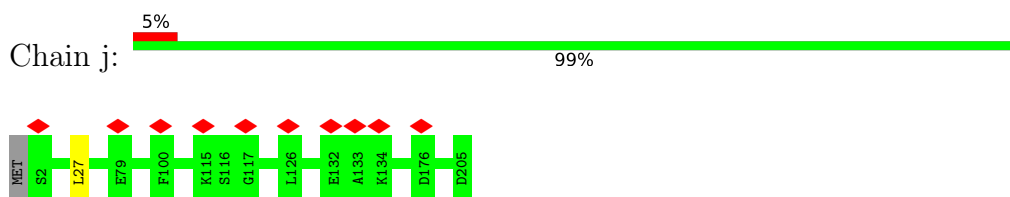

- Molecule 6: Proteasome subunit beta type-4

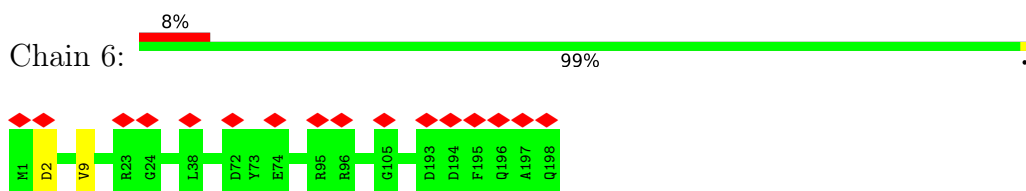

- Molecule 6: Proteasome subunit beta type-4



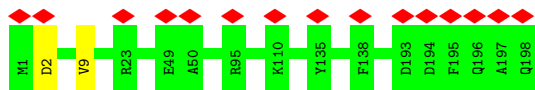

• Molecule 7: Proteasome subunit beta type-5

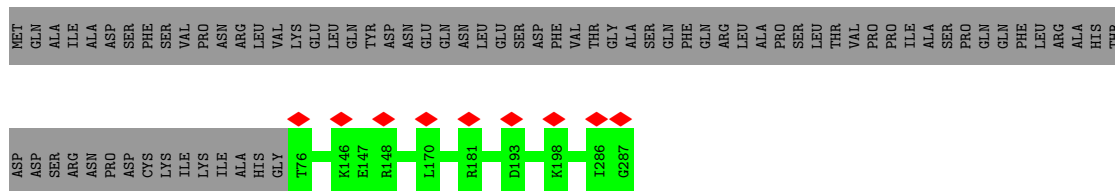
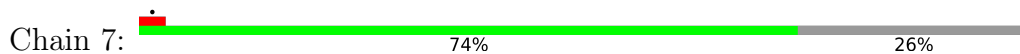

• Molecule 7: Proteasome subunit beta type-5

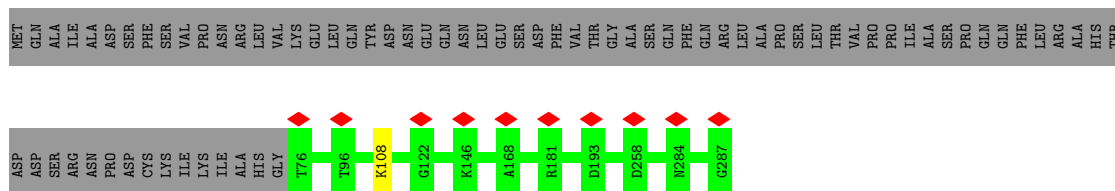

• Molecule 8: Proteasome subunit alpha type-1

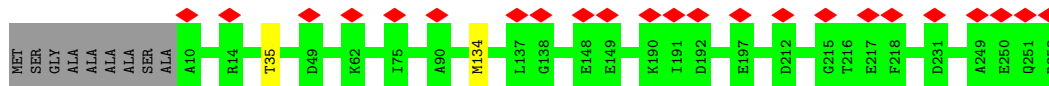

• Molecule 8: Proteasome subunit alpha type-1

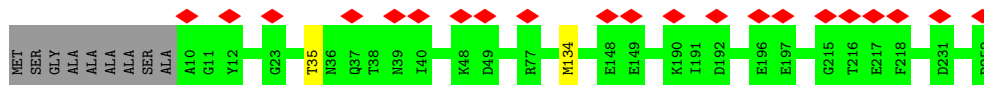

• Molecule 9: Proteasome subunit alpha type-2

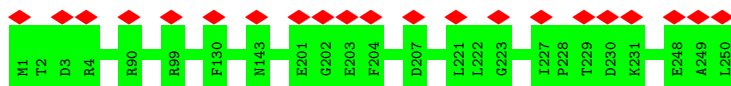

• Molecule 9: Proteasome subunit alpha type-2



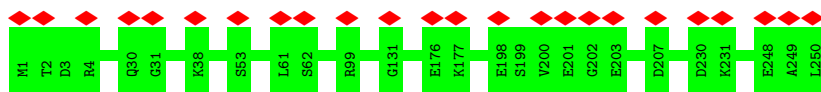

- Molecule 10: Proteasome subunit alpha type-3

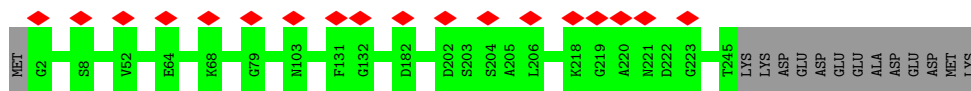
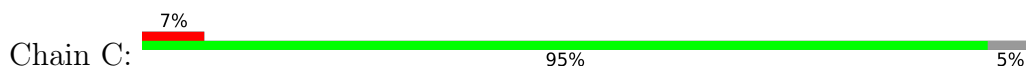

- Molecule 10: Proteasome subunit alpha type-3

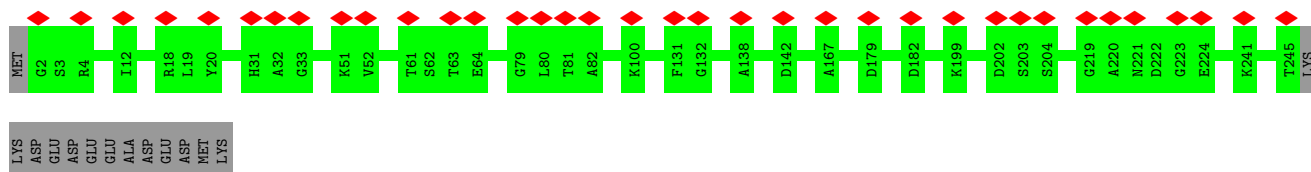
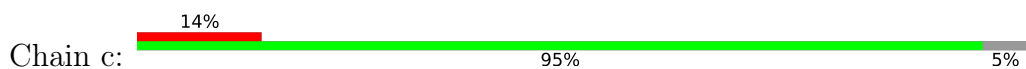

- Molecule 11: Proteasome subunit alpha type-4

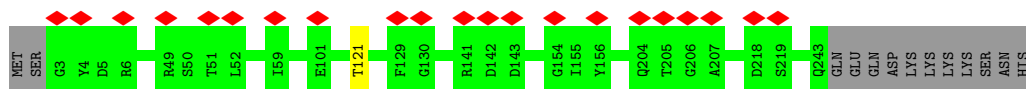
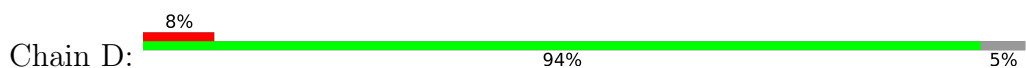

- Molecule 11: Proteasome subunit alpha type-4

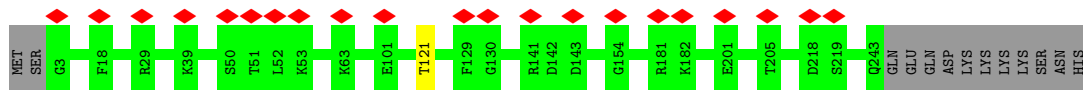

- Molecule 12: Proteasome subunit alpha type-5

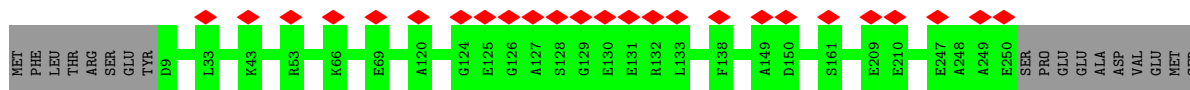

- Molecule 12: Proteasome subunit alpha type-5

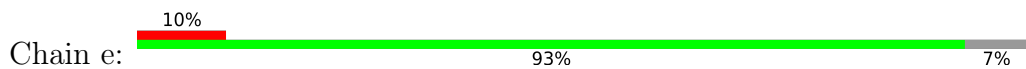

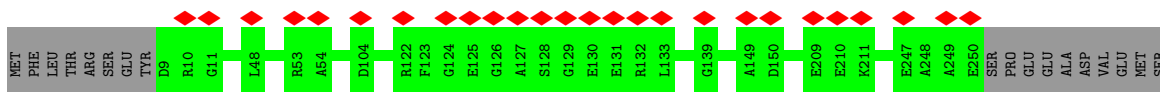

- Molecule 13: Proteasome subunit alpha type-6

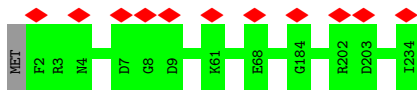

- Molecule 13: Proteasome subunit alpha type-6

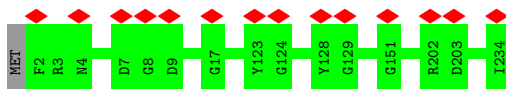

- Molecule 14: Probable proteasome subunit alpha type-7

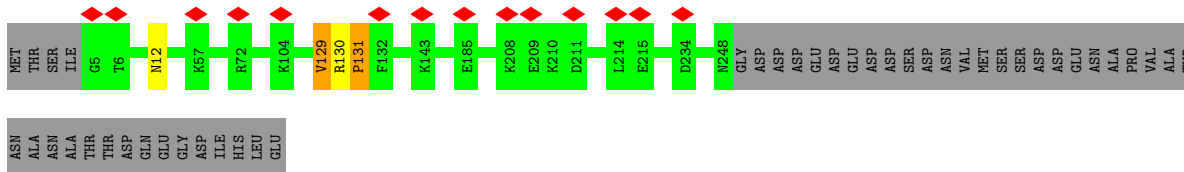
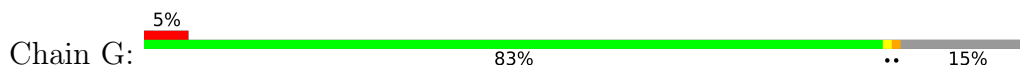

- Molecule 14: Probable proteasome subunit alpha type-7

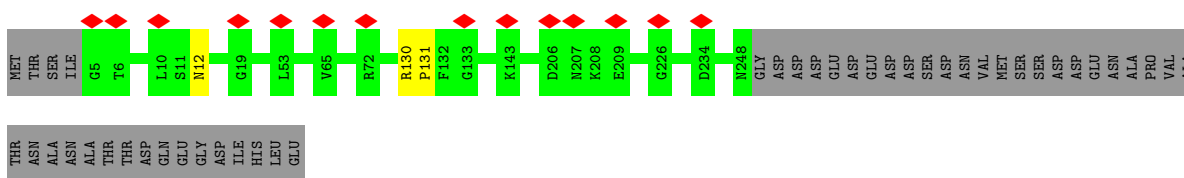
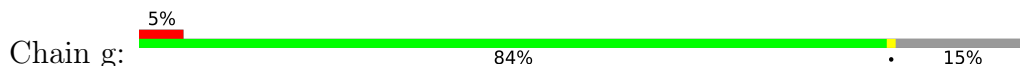

- Molecule 15: 26S protease regulatory subunit 7 homolog

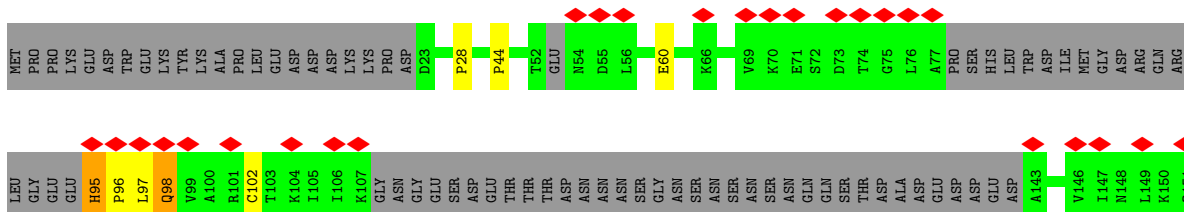
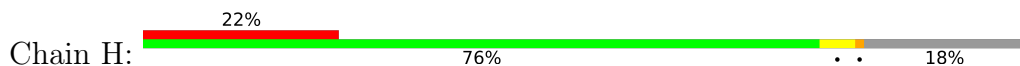

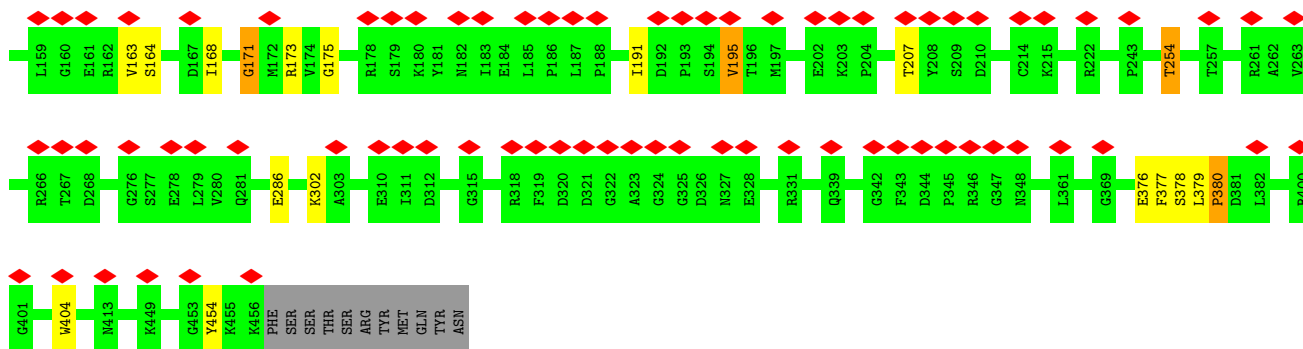

• Molecule 16: 26S protease regulatory subunit 4 homolog

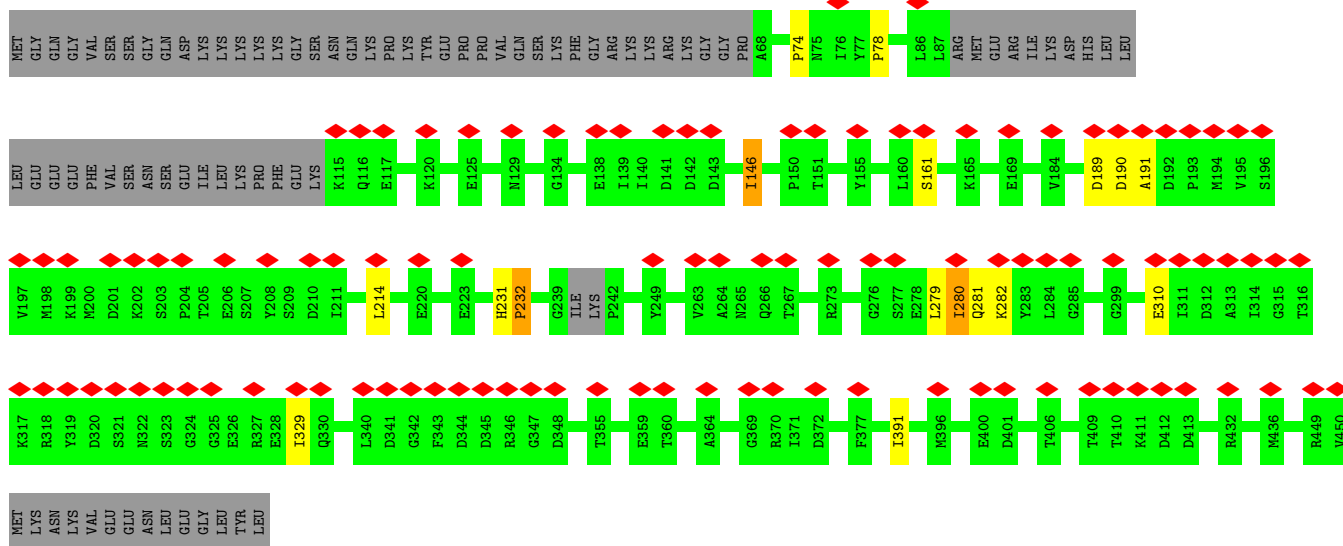
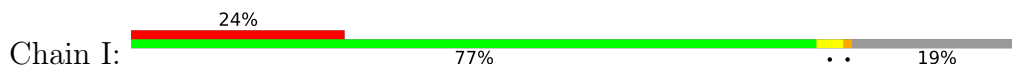

• Molecule 17: 26S protease regulatory subunit 8 homolog

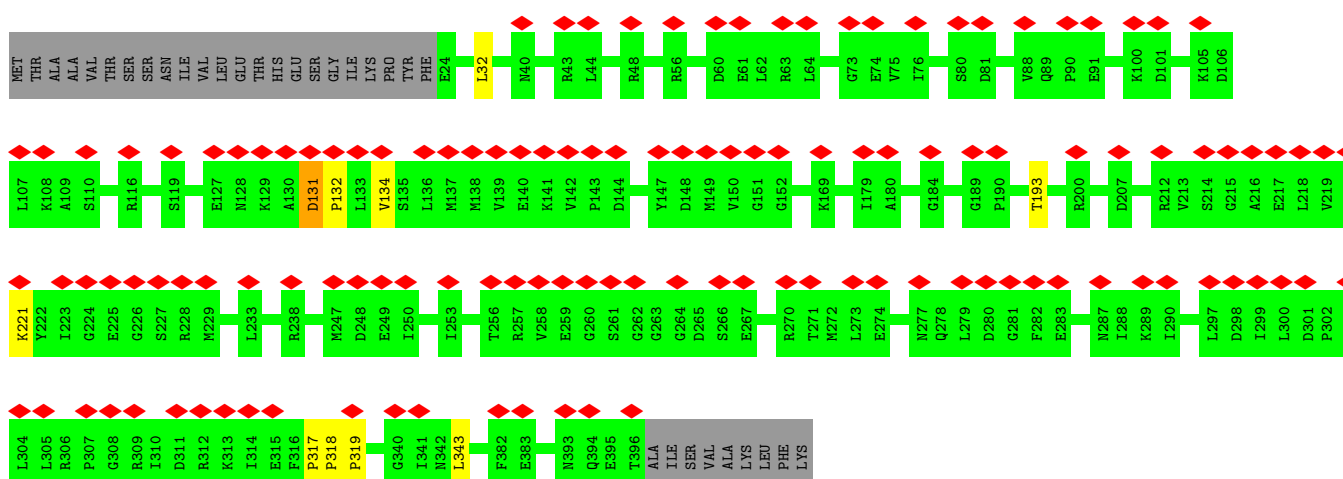

- Molecule 18: 26S protease regulatory subunit 6B homolog

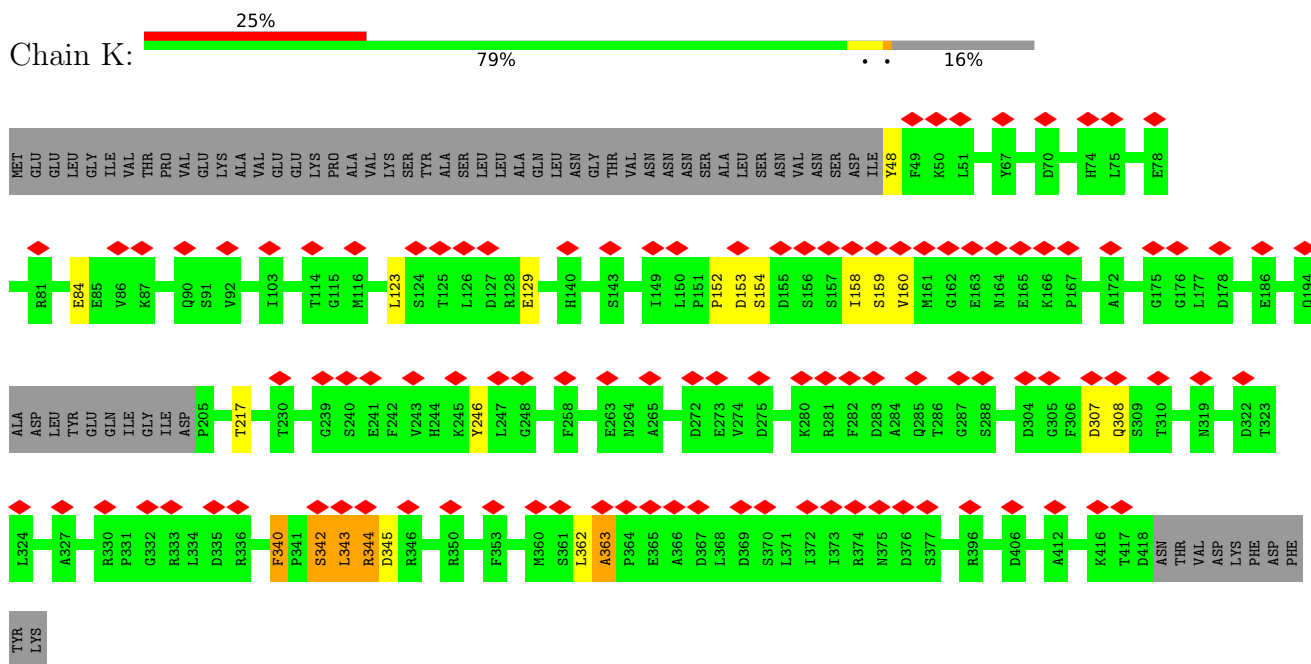

- Molecule 19: 26S protease subunit RPT4

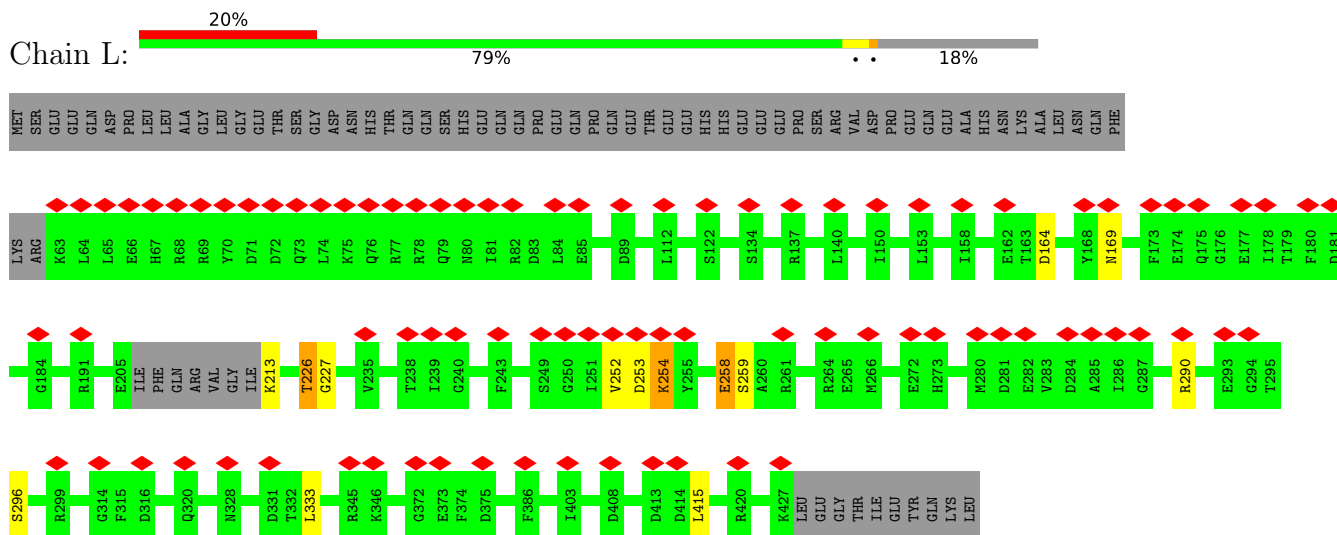

- Molecule 20: 26S protease regulatory subunit 6A

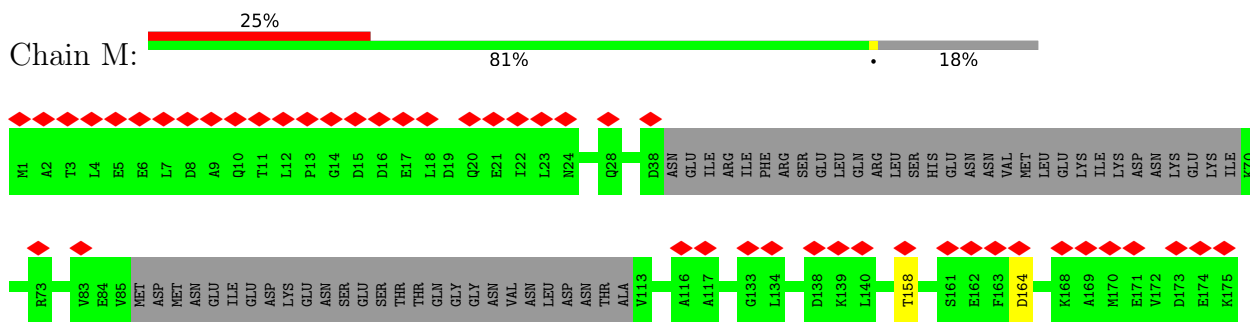

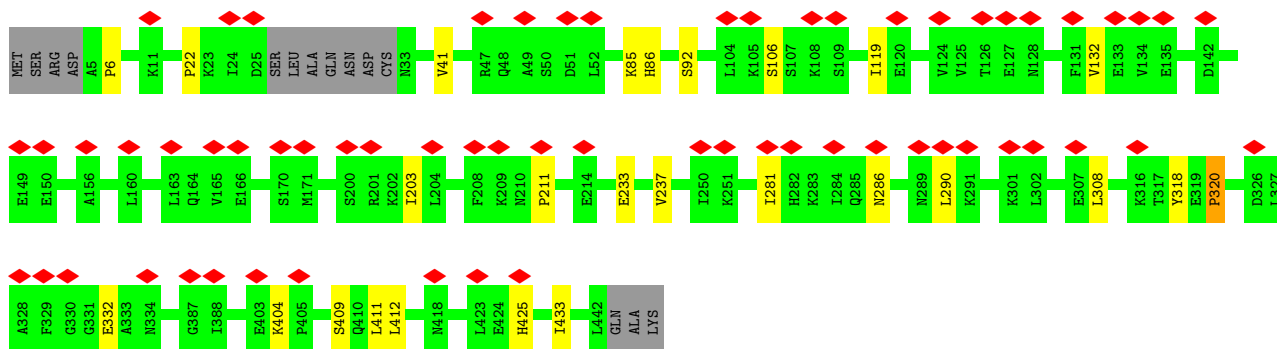

• Molecule 24: 26S proteasome regulatory subunit RPN6

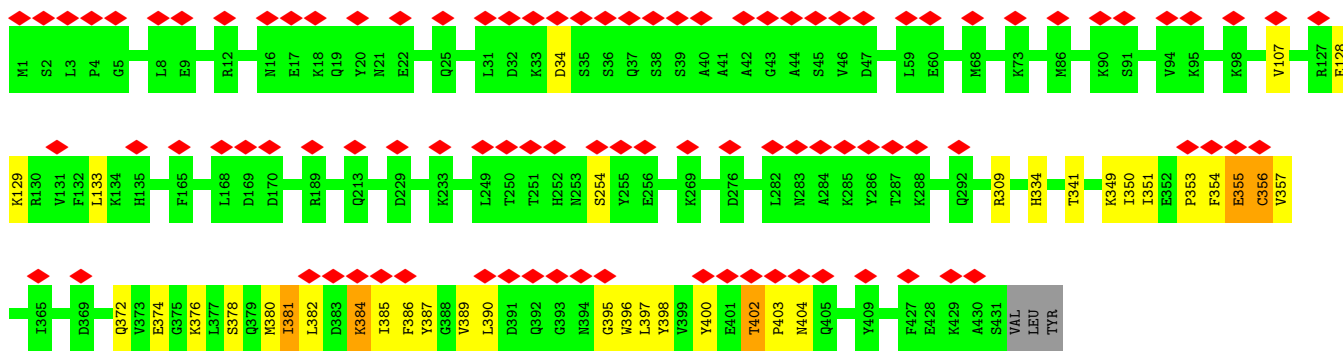
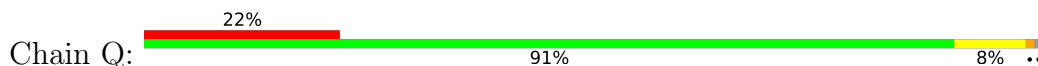

• Molecule 25: 26S proteasome regulatory subunit RPN7

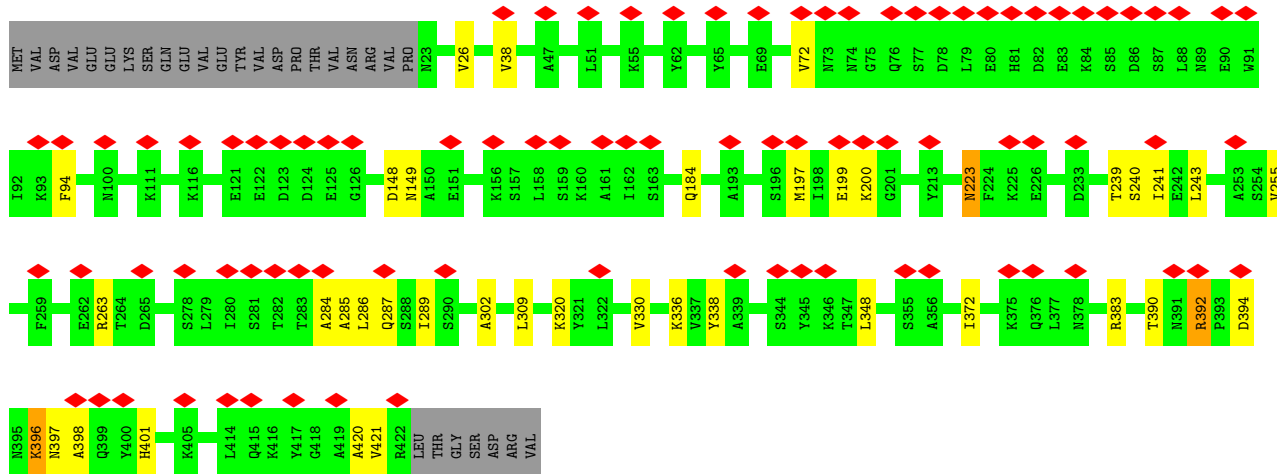
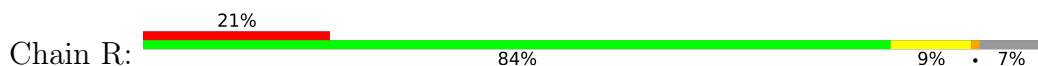

• Molecule 26: 26S proteasome regulatory subunit RPN3

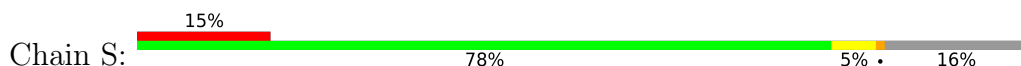

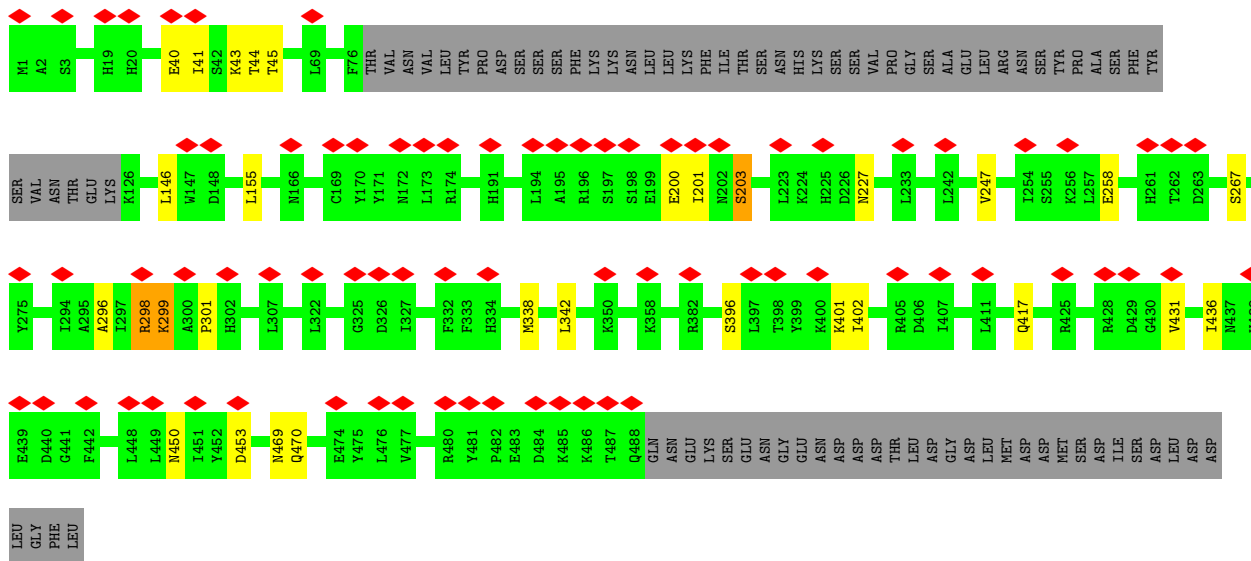

• Molecule 27: 26S proteasome regulatory subunit RPN12

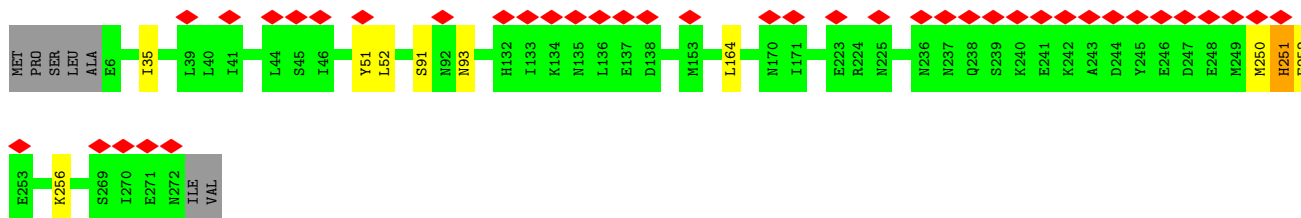

• Molecule 28: 26S proteasome regulatory subunit RPN8

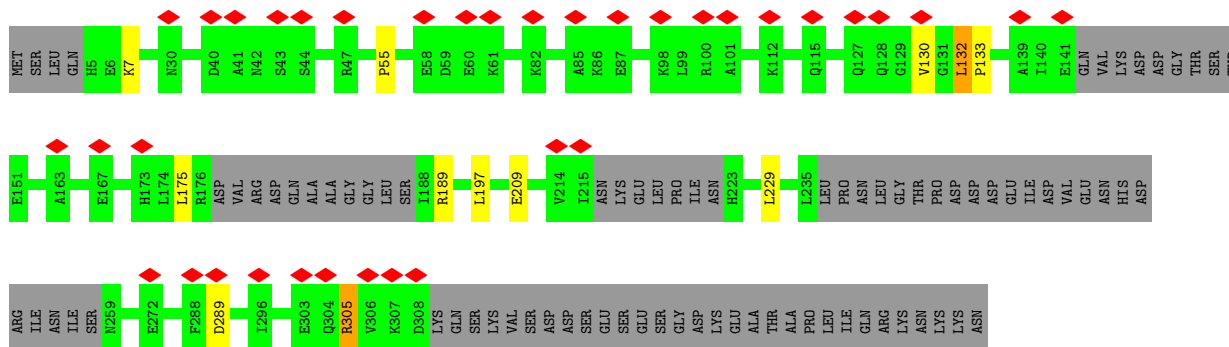

• Molecule 29: Ubiquitin carboxyl-terminal hydrolase RPN11

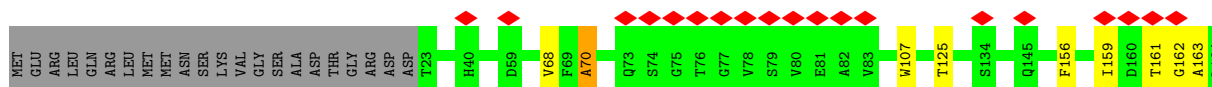
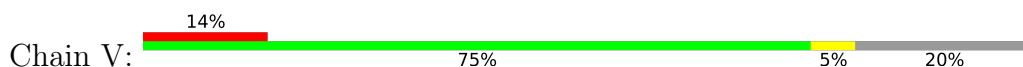

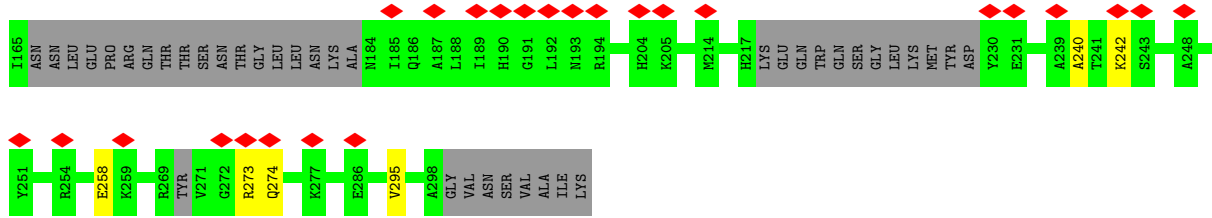

• Molecule 30: 26S proteasome regulatory subunit RPN10

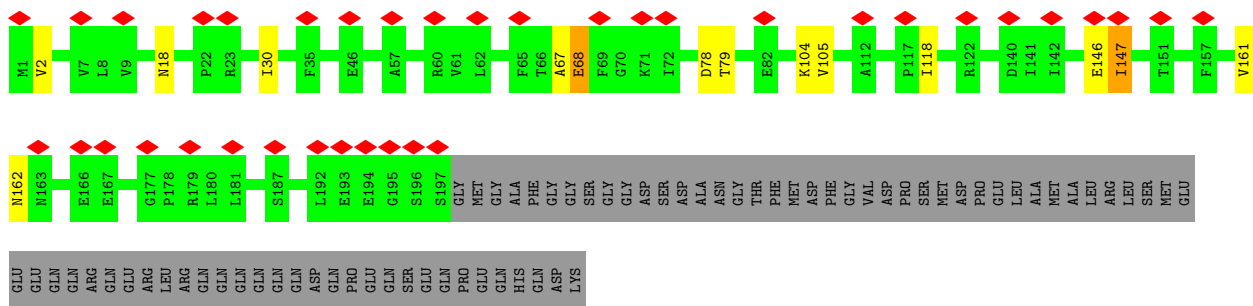

• Molecule 31: 26S proteasome regulatory subunit RPN13

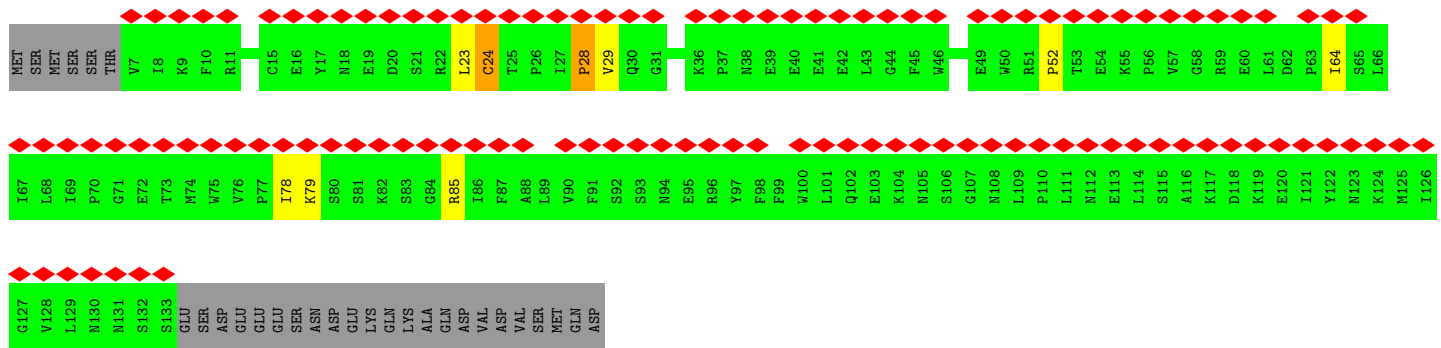
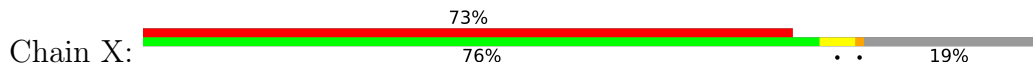

• Molecule 32: 26S proteasome complex subunit SEM1

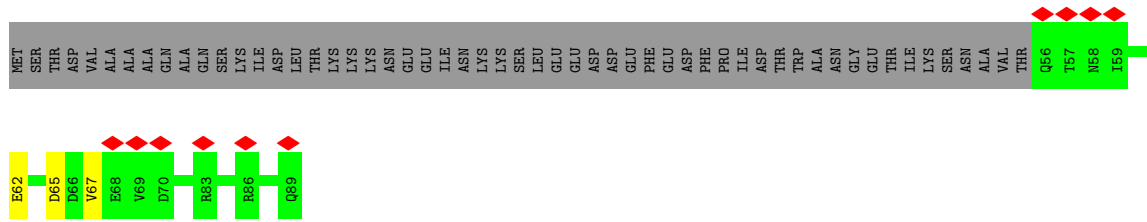

• Molecule 33: 26S proteasome regulatory subunit RPN1



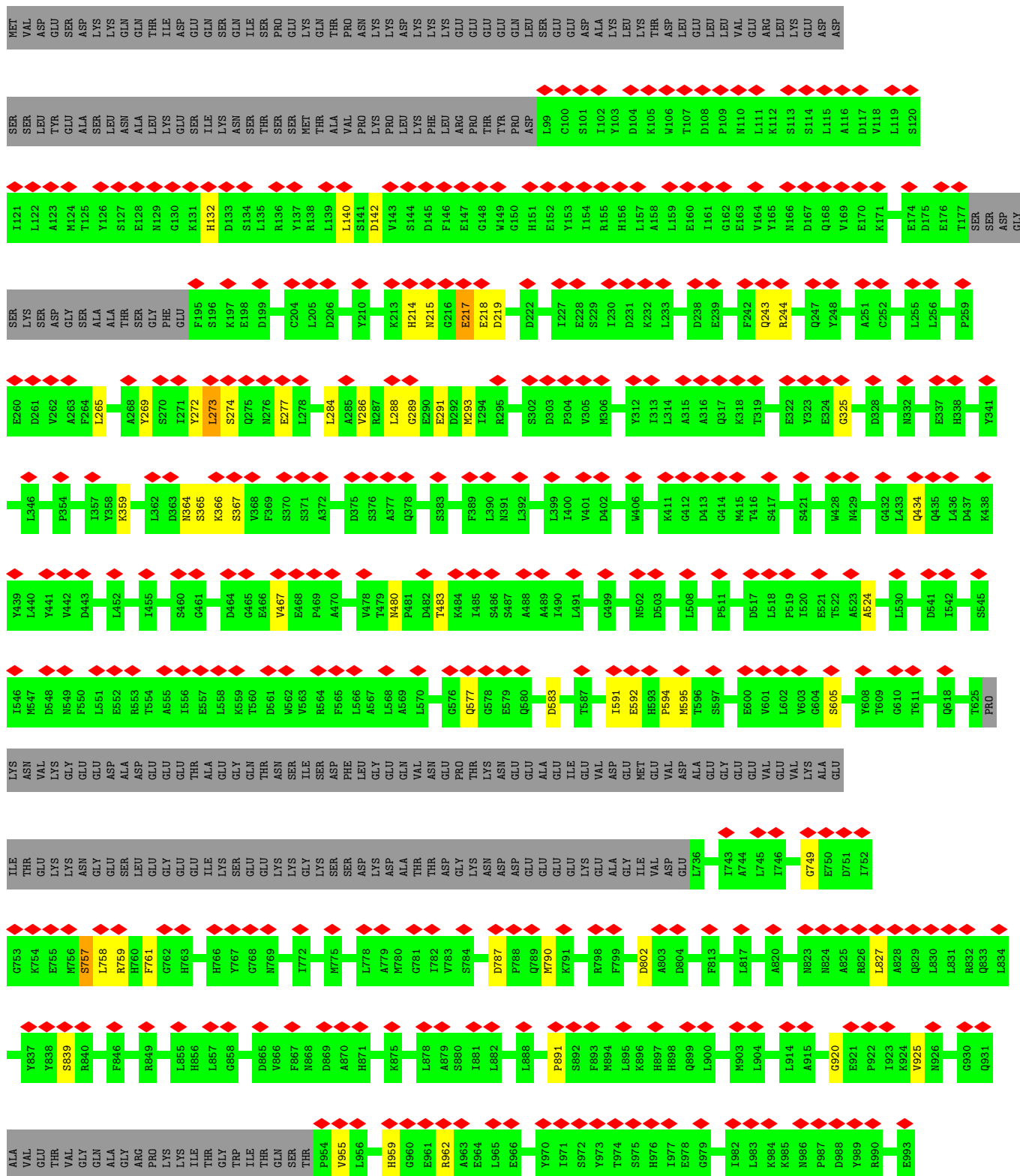

4 Experimental information

Property	Value	Source
EM reconstruction method	SINGLE PARTICLE	Depositor
Imposed symmetry	POINT, C1	Depositor
Number of particles used	25151	Depositor
Resolution determination method	FSC 0.143 CUT-OFF	Depositor
CTF correction method	Each micrographs	Depositor
Microscope	FEI TITAN KRIOS	Depositor
Voltage (kV)	300	Depositor
Electron dose ($e^-/\text{\AA}^2$)	Not provided	
Minimum defocus (nm)	1.5	Depositor
Maximum defocus (nm)	2.5	Depositor
Magnification	75000	Depositor
Image detector	FEI FALCON II (4k x 4k)	Depositor
Maximum map value	0.292	Depositor
Minimum map value	-0.121	Depositor
Average map value	0.001	Depositor
Map value standard deviation	0.015	Depositor
Recommended contour level	0.095	Depositor
Map size (\AA)	537.6, 537.6, 537.6	wwPDB
Map dimensions	256, 256, 256	wwPDB
Map angles ($^\circ$)	90.0, 90.0, 90.0	wwPDB
Pixel spacing (\AA)	2.1, 2.1, 2.1	Depositor

5 Model quality [i](#)

5.1 Standard geometry [i](#)

The Z score for a bond length (or angle) is the number of standard deviations the observed value is removed from the expected value. A bond length (or angle) with $|Z| > 5$ is considered an outlier worth inspection. RMSZ is the root-mean-square of all Z scores of the bond lengths (or angles).

Mol	Chain	Bond lengths		Bond angles	
		RMSZ	# Z >5	RMSZ	# Z >5
1	1	0.55	0/1795	0.60	0/2420
1	8	0.55	0/1795	0.60	0/2420
2	2	0.55	0/1855	0.61	0/2514
2	9	0.55	0/1855	0.61	0/2514
3	3	0.59	0/1602	0.59	0/2166
3	h	0.59	0/1603	0.59	0/2168
4	4	0.54	0/1715	0.61	0/2326
4	i	0.54	0/1715	0.61	0/2326
5	5	0.53	0/1611	0.61	1/2174 (0.0%)
5	j	0.53	0/1608	0.61	1/2170 (0.0%)
6	6	0.53	0/1613	0.60	0/2173
6	k	0.53	0/1613	0.60	0/2173
7	7	0.55	0/1681	0.60	0/2274
7	l	0.55	0/1681	0.60	0/2274
8	A	0.56	0/1959	0.61	1/2652 (0.0%)
8	a	0.56	0/1959	0.61	1/2652 (0.0%)
9	B	0.53	0/1952	0.59	0/2642
9	b	0.53	0/1952	0.59	0/2642
10	C	0.54	0/1934	0.60	0/2618
10	c	0.54	0/1934	0.60	0/2618
11	D	0.50	0/1919	0.58	0/2598
11	d	0.50	0/1919	0.58	0/2598
12	E	0.48	0/1886	0.59	0/2541
12	e	0.48	0/1886	0.59	0/2541
13	F	0.49	0/1823	0.58	0/2463
13	f	0.49	0/1823	0.58	0/2463
14	G	0.54	1/1936 (0.1%)	0.58	0/2614
14	g	0.55	1/1936 (0.1%)	0.59	1/2614 (0.0%)
15	H	0.53	1/2915 (0.0%)	0.74	7/3927 (0.2%)
16	I	0.46	0/2681	0.73	4/3620 (0.1%)
17	J	0.48	0/2945	0.67	2/3952 (0.1%)
18	K	0.52	0/2872	0.75	3/3874 (0.1%)
19	L	0.50	0/2870	0.70	4/3858 (0.1%)
20	M	0.48	0/2785	0.69	1/3763 (0.0%)

Mol	Chain	Bond lengths		Bond angles	
		RMSZ	# Z >5	RMSZ	# Z >5
21	N	0.44	0/6679	0.62	2/9037 (0.0%)
22	O	0.50	1/2958 (0.0%)	0.78	5/4005 (0.1%)
23	P	0.53	0/3520	0.74	4/4752 (0.1%)
24	Q	0.48	0/3525	0.61	0/4745
25	R	0.59	1/3240 (0.0%)	0.95	8/4371 (0.2%)
26	S	0.46	0/3439	0.76	4/4657 (0.1%)
27	T	0.46	0/2244	0.65	1/3029 (0.0%)
28	U	0.48	0/2075	0.69	2/2795 (0.1%)
29	V	0.50	0/1939	0.77	2/2613 (0.1%)
30	W	0.41	0/1557	0.67	0/2111
31	X	0.41	0/1058	0.66	0/1432
32	Y	0.44	0/244	0.68	0/328
33	Z	0.41	0/5787	0.68	4/7857 (0.1%)
All	All	0.51	5/105893 (0.0%)	0.66	58/143074 (0.0%)

Chiral center outliers are detected by calculating the chiral volume of a chiral center and verifying if the center is modelled as a planar moiety or with the opposite hand. A planarity outlier is detected by checking planarity of atoms in a peptide group, atoms in a mainchain group or atoms of a sidechain that are expected to be planar.

Mol	Chain	#Chirality outliers	#Planarity outliers
15	H	0	11
16	I	0	4
17	J	0	1
18	K	0	7
19	L	0	5
20	M	0	4
21	N	0	6
22	O	0	17
23	P	0	11
24	Q	0	6
25	R	0	5
26	S	0	16
27	T	0	4
28	U	0	7
29	V	0	6
30	W	0	6
31	X	0	6
32	Y	0	2
33	Z	0	7
All	All	0	131

All (5) bond length outliers are listed below:

Mol	Chain	Res	Type	Atoms	Z	Observed(Å)	Ideal(Å)
25	R	330	VAL	C-N	15.59	1.69	1.34
15	H	380	PRO	N-CD	5.39	1.55	1.47
14	G	131	PRO	N-CD	5.26	1.55	1.47
14	g	131	PRO	N-CD	5.26	1.55	1.47
22	O	34	GLU	C-N	5.07	1.45	1.34

The worst 5 of 58 bond angle outliers are listed below:

Mol	Chain	Res	Type	Atoms	Z	Observed(°)	Ideal(°)
25	R	330	VAL	O-C-N	27.20	166.22	122.70
25	R	330	VAL	CA-C-N	-21.39	70.15	117.20
25	R	330	VAL	C-N-CA	-19.67	72.53	121.70
25	R	338	TYR	CB-CA-C	11.26	132.92	110.40
21	N	152	LEU	CA-CB-CG	9.73	137.68	115.30

There are no chirality outliers.

5 of 131 planarity outliers are listed below:

Mol	Chain	Res	Type	Group
15	H	102	CYS	Peptide
15	H	164	SER	Peptide
15	H	171	GLY	Peptide
15	H	173	ARG	Peptide
15	H	175	GLY	Peptide

5.2 Too-close contacts [i](#)

Due to software issues we are unable to calculate clashes - this section is therefore empty.

5.3 Torsion angles [i](#)

5.3.1 Protein backbone [i](#)

In the following table, the Percentiles column shows the percent Ramachandran outliers of the chain as a percentile score with respect to all PDB entries followed by that with respect to all EM entries.

The Analysed column shows the number of residues for which the backbone conformation was analysed, and the total number of residues.

Mol	Chain	Analysed	Favoured	Allowed	Outliers	Percentiles	
1	1	220/241 (91%)	207 (94%)	13 (6%)	0	100	100
1	8	220/241 (91%)	207 (94%)	13 (6%)	0	100	100
2	2	231/266 (87%)	222 (96%)	7 (3%)	2 (1%)	17	56
2	9	231/266 (87%)	222 (96%)	7 (3%)	2 (1%)	17	56
3	3	203/215 (94%)	189 (93%)	12 (6%)	2 (1%)	15	54
3	h	203/215 (94%)	188 (93%)	13 (6%)	2 (1%)	15	54
4	4	220/261 (84%)	211 (96%)	9 (4%)	0	100	100
4	i	220/261 (84%)	211 (96%)	9 (4%)	0	100	100
5	5	202/205 (98%)	194 (96%)	8 (4%)	0	100	100
5	j	202/205 (98%)	194 (96%)	8 (4%)	0	100	100
6	6	196/198 (99%)	186 (95%)	8 (4%)	2 (1%)	15	54
6	k	196/198 (99%)	186 (95%)	8 (4%)	2 (1%)	15	54
7	7	210/287 (73%)	203 (97%)	7 (3%)	0	100	100
7	l	210/287 (73%)	203 (97%)	7 (3%)	0	100	100
8	A	241/252 (96%)	227 (94%)	13 (5%)	1 (0%)	34	72
8	a	241/252 (96%)	227 (94%)	13 (5%)	1 (0%)	34	72
9	B	248/250 (99%)	235 (95%)	13 (5%)	0	100	100
9	b	248/250 (99%)	235 (95%)	13 (5%)	0	100	100
10	C	242/258 (94%)	232 (96%)	10 (4%)	0	100	100
10	c	242/258 (94%)	232 (96%)	10 (4%)	0	100	100
11	D	239/254 (94%)	224 (94%)	14 (6%)	1 (0%)	34	72
11	d	239/254 (94%)	224 (94%)	14 (6%)	1 (0%)	34	72
12	E	240/260 (92%)	228 (95%)	12 (5%)	0	100	100
12	e	240/260 (92%)	228 (95%)	12 (5%)	0	100	100
13	F	231/234 (99%)	221 (96%)	10 (4%)	0	100	100
13	f	231/234 (99%)	221 (96%)	10 (4%)	0	100	100
14	G	242/288 (84%)	224 (93%)	14 (6%)	4 (2%)	9	43
14	g	242/288 (84%)	226 (93%)	15 (6%)	1 (0%)	34	72
15	H	373/467 (80%)	301 (81%)	60 (16%)	12 (3%)	4	30
16	I	348/437 (80%)	297 (85%)	42 (12%)	9 (3%)	5	34
17	J	371/405 (92%)	325 (88%)	39 (10%)	7 (2%)	8	40
18	K	357/428 (83%)	300 (84%)	45 (13%)	12 (3%)	3	29

Continued on next page...

Continued from previous page...

Mol	Chain	Analysed	Favoured	Allowed	Outliers	Percentiles	
19	L	354/437 (81%)	291 (82%)	58 (16%)	5 (1%)	11	47
20	M	349/434 (80%)	310 (89%)	38 (11%)	1 (0%)	41	76
21	N	846/945 (90%)	665 (79%)	173 (20%)	8 (1%)	17	56
22	O	372/393 (95%)	263 (71%)	83 (22%)	26 (7%)	1	16
23	P	427/445 (96%)	315 (74%)	100 (23%)	12 (3%)	5	33
24	Q	429/434 (99%)	325 (76%)	92 (21%)	12 (3%)	5	33
25	R	398/429 (93%)	280 (70%)	95 (24%)	23 (6%)	1	20
26	S	435/523 (83%)	332 (76%)	89 (20%)	14 (3%)	4	30
27	T	265/274 (97%)	202 (76%)	60 (23%)	3 (1%)	14	52
28	U	244/338 (72%)	202 (83%)	37 (15%)	5 (2%)	7	40
29	V	237/306 (78%)	185 (78%)	44 (19%)	8 (3%)	3	29
30	W	195/268 (73%)	154 (79%)	33 (17%)	8 (4%)	3	25
31	X	125/156 (80%)	96 (77%)	24 (19%)	5 (4%)	3	26
32	Y	32/89 (36%)	21 (66%)	10 (31%)	1 (3%)	4	31
33	Z	738/993 (74%)	589 (80%)	119 (16%)	30 (4%)	3	25
All	All	13225/15139 (87%)	11460 (87%)	1543 (12%)	222 (2%)	13	43

5 of 222 Ramachandran outliers are listed below:

Mol	Chain	Res	Type
14	G	130	ARG
14	G	131	PRO
15	H	377	PHE
15	H	378	SER
15	H	380	PRO

5.3.2 Protein sidechains [i](#)

In the following table, the Percentiles column shows the percent sidechain outliers of the chain as a percentile score with respect to all PDB entries followed by that with respect to all EM entries.

The Analysed column shows the number of residues for which the sidechain conformation was analysed, and the total number of residues.

Mol	Chain	Analysed	Rotameric	Outliers	Percentiles	
1	1	185/201 (92%)	185 (100%)	0	100	100

Continued on next page...

Continued from previous page...

Mol	Chain	Analysed	Rotameric	Outliers	Percentiles	
1	8	185/201 (92%)	185 (100%)	0	100	100
2	2	199/224 (89%)	199 (100%)	0	100	100
2	9	199/224 (89%)	199 (100%)	0	100	100
3	3	167/178 (94%)	167 (100%)	0	100	100
3	h	168/178 (94%)	168 (100%)	0	100	100
4	4	181/214 (85%)	181 (100%)	0	100	100
4	i	181/214 (85%)	181 (100%)	0	100	100
5	5	172/173 (99%)	172 (100%)	0	100	100
5	j	171/173 (99%)	171 (100%)	0	100	100
6	6	175/175 (100%)	175 (100%)	0	100	100
6	k	175/175 (100%)	175 (100%)	0	100	100
7	7	169/235 (72%)	169 (100%)	0	100	100
7	l	169/235 (72%)	168 (99%)	1 (1%)	86	92
8	A	207/210 (99%)	207 (100%)	0	100	100
8	a	207/210 (99%)	207 (100%)	0	100	100
9	B	209/209 (100%)	209 (100%)	0	100	100
9	b	209/209 (100%)	209 (100%)	0	100	100
10	C	203/216 (94%)	203 (100%)	0	100	100
10	c	203/216 (94%)	203 (100%)	0	100	100
11	D	213/226 (94%)	213 (100%)	0	100	100
11	d	213/226 (94%)	213 (100%)	0	100	100
12	E	198/215 (92%)	198 (100%)	0	100	100
12	e	198/215 (92%)	198 (100%)	0	100	100
13	F	192/193 (100%)	192 (100%)	0	100	100
13	f	192/193 (100%)	192 (100%)	0	100	100
14	G	201/239 (84%)	200 (100%)	1 (0%)	88	93
14	g	201/239 (84%)	201 (100%)	0	100	100
15	H	296/399 (74%)	292 (99%)	4 (1%)	67	81
16	I	282/385 (73%)	279 (99%)	3 (1%)	73	85
17	J	319/352 (91%)	318 (100%)	1 (0%)	92	95
18	K	313/374 (84%)	309 (99%)	4 (1%)	69	82

Continued on next page...

Continued from previous page...

Mol	Chain	Analysed	Rotameric	Outliers	Percentiles	
19	L	306/377 (81%)	303 (99%)	3 (1%)	76	86
20	M	303/375 (81%)	303 (100%)	0	100	100
21	N	714/797 (90%)	712 (100%)	2 (0%)	92	95
22	O	306/368 (83%)	300 (98%)	6 (2%)	55	73
23	P	384/415 (92%)	384 (100%)	0	100	100
24	Q	387/391 (99%)	362 (94%)	25 (6%)	17	44
25	R	342/379 (90%)	333 (97%)	9 (3%)	46	67
26	S	349/489 (71%)	349 (100%)	0	100	100
27	T	250/256 (98%)	247 (99%)	3 (1%)	71	84
28	U	232/308 (75%)	232 (100%)	0	100	100
29	V	211/268 (79%)	211 (100%)	0	100	100
30	W	171/230 (74%)	169 (99%)	2 (1%)	71	84
31	X	116/144 (81%)	116 (100%)	0	100	100
32	Y	18/81 (22%)	18 (100%)	0	100	100
33	Z	606/850 (71%)	588 (97%)	18 (3%)	41	63
All	All	11247/13054 (86%)	11165 (99%)	82 (1%)	84	90

5 of 82 residues with a non-rotameric sidechain are listed below:

Mol	Chain	Res	Type
25	R	396	LYS
33	Z	367	SER
27	T	252	GLU
33	Z	273	LEU
33	Z	758	LEU

Sometimes sidechains can be flipped to improve hydrogen bonding and reduce clashes. 5 of 238 such sidechains are listed below:

Mol	Chain	Res	Type
23	P	210	ASN
14	g	248	ASN
26	S	235	ASN
14	g	127	ASN
7	l	251	ASN

5.3.3 RNA [i](#)

There are no RNA molecules in this entry.

5.4 Non-standard residues in protein, DNA, RNA chains [i](#)

There are no non-standard protein/DNA/RNA residues in this entry.

5.5 Carbohydrates [i](#)

There are no monosaccharides in this entry.

5.6 Ligand geometry [i](#)

There are no ligands in this entry.

5.7 Other polymers [i](#)

There are no such residues in this entry.

5.8 Polymer linkage issues [i](#)

The following chains have linkage breaks:

Mol	Chain	Number of breaks
25	R	1

All chain breaks are listed below:

Model	Chain	Residue-1	Atom-1	Residue-2	Atom-2	Distance (Å)
1	R	330:VAL	C	331:ARG	N	1.69

6 Map visualisation [i](#)

This section contains visualisations of the EMDB entry EMD-6575. These allow visual inspection of the internal detail of the map and identification of artifacts.

No raw map or half-maps were deposited for this entry and therefore no images, graphs, etc. pertaining to the raw map can be shown.

6.1 Orthogonal projections [i](#)

6.1.1 Primary map

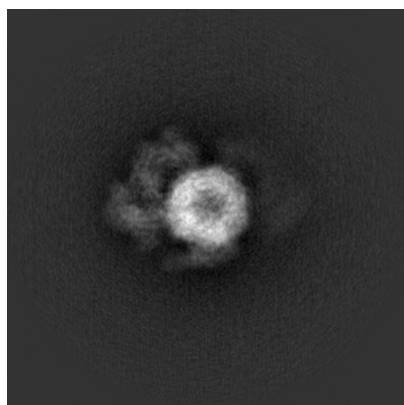

X



Y

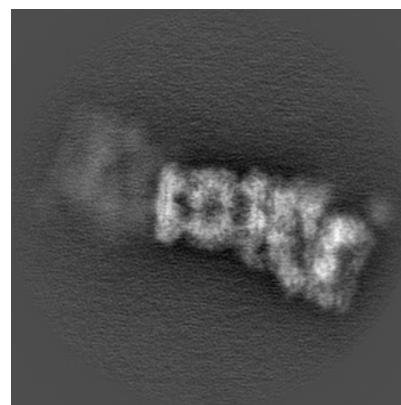

Z

The images above show the map projected in three orthogonal directions.

6.2 Central slices [i](#)

6.2.1 Primary map

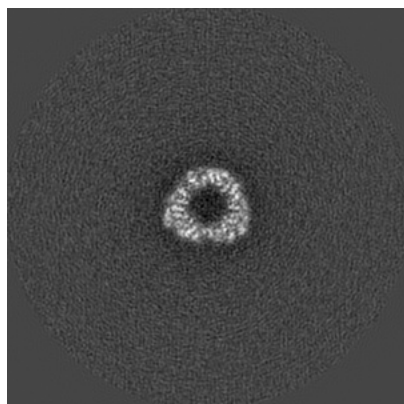

X Index: 128

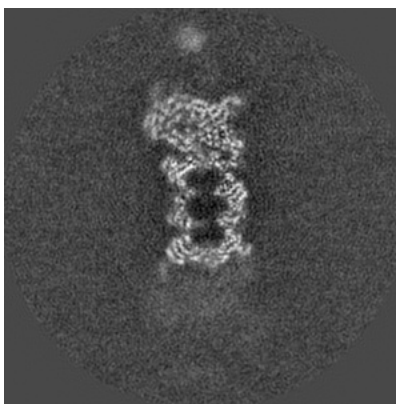

Y Index: 128

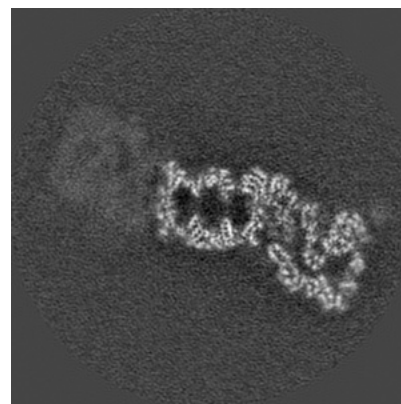

Z Index: 128

The images above show central slices of the map in three orthogonal directions.

6.3 Largest variance slices [i](#)

6.3.1 Primary map

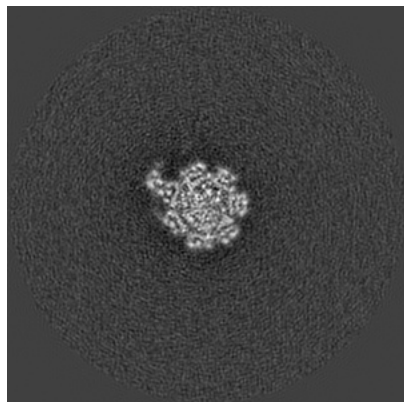

X Index: 155

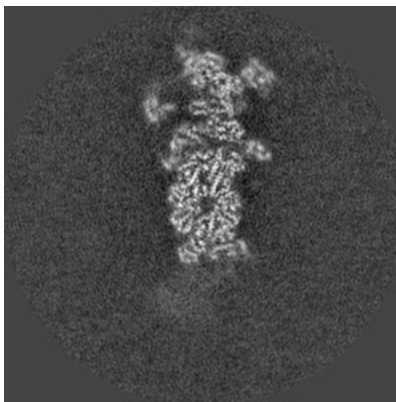

Y Index: 116

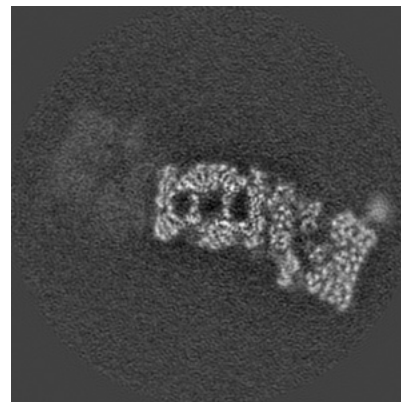

Z Index: 122

The images above show the largest variance slices of the map in three orthogonal directions.

6.4 Orthogonal standard-deviation projections (False-color) [i](#)

6.4.1 Primary map

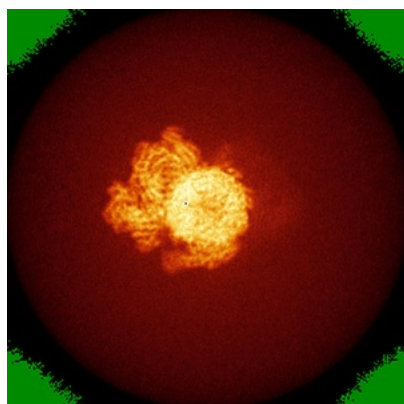

X

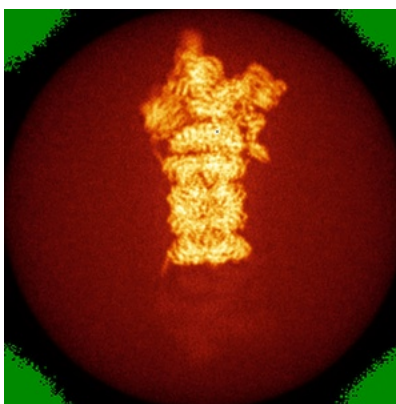

Y

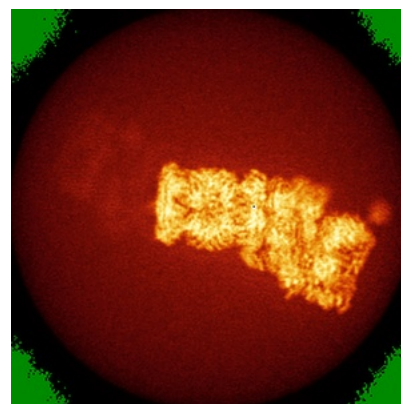

Z

The images above show the map standard deviation projections with false color in three orthogonal directions. Minimum values are shown in green, max in blue, and dark to light orange shades represent small to large values respectively.

6.5 Orthogonal surface views [i](#)

6.5.1 Primary map

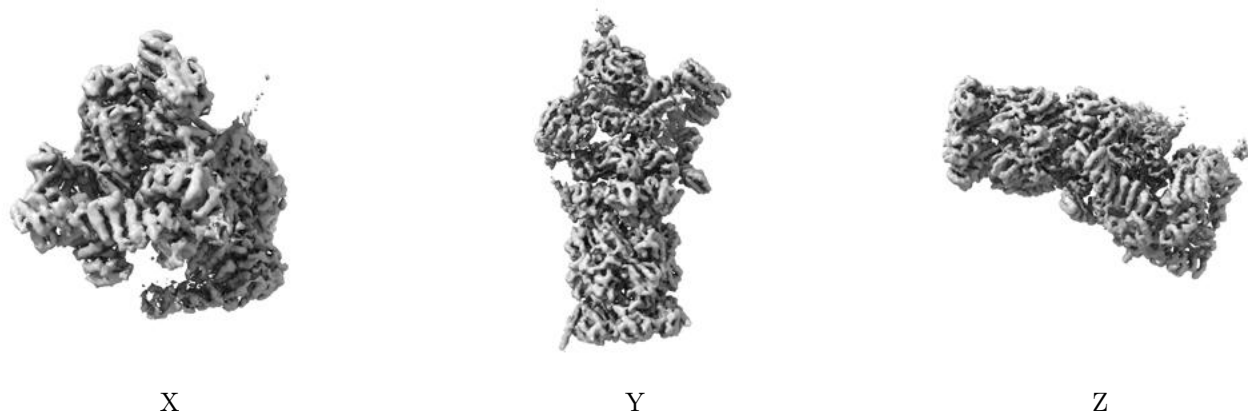

The images above show the 3D surface view of the map at the recommended contour level 0.095. These images, in conjunction with the slice images, may facilitate assessment of whether an appropriate contour level has been provided.

6.6 Mask visualisation [i](#)

This section was not generated. No masks/segmentation were deposited.

7 Map analysis [i](#)

This section contains the results of statistical analysis of the map.

7.1 Map-value distribution [i](#)

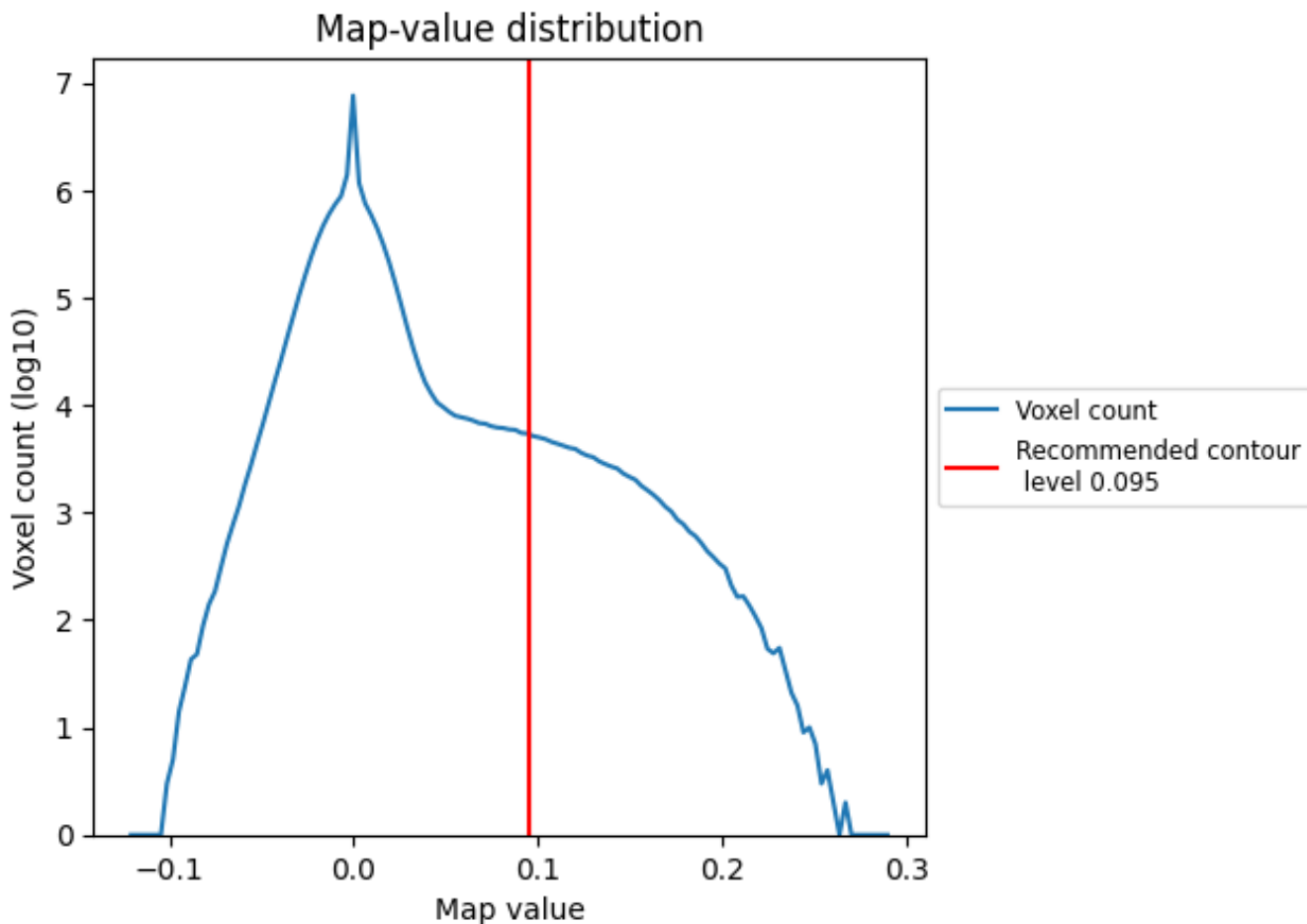

The map-value distribution is plotted in 128 intervals along the x-axis. The y-axis is logarithmic. A spike in this graph at zero usually indicates that the volume has been masked.

7.2 Volume estimate [i](#)

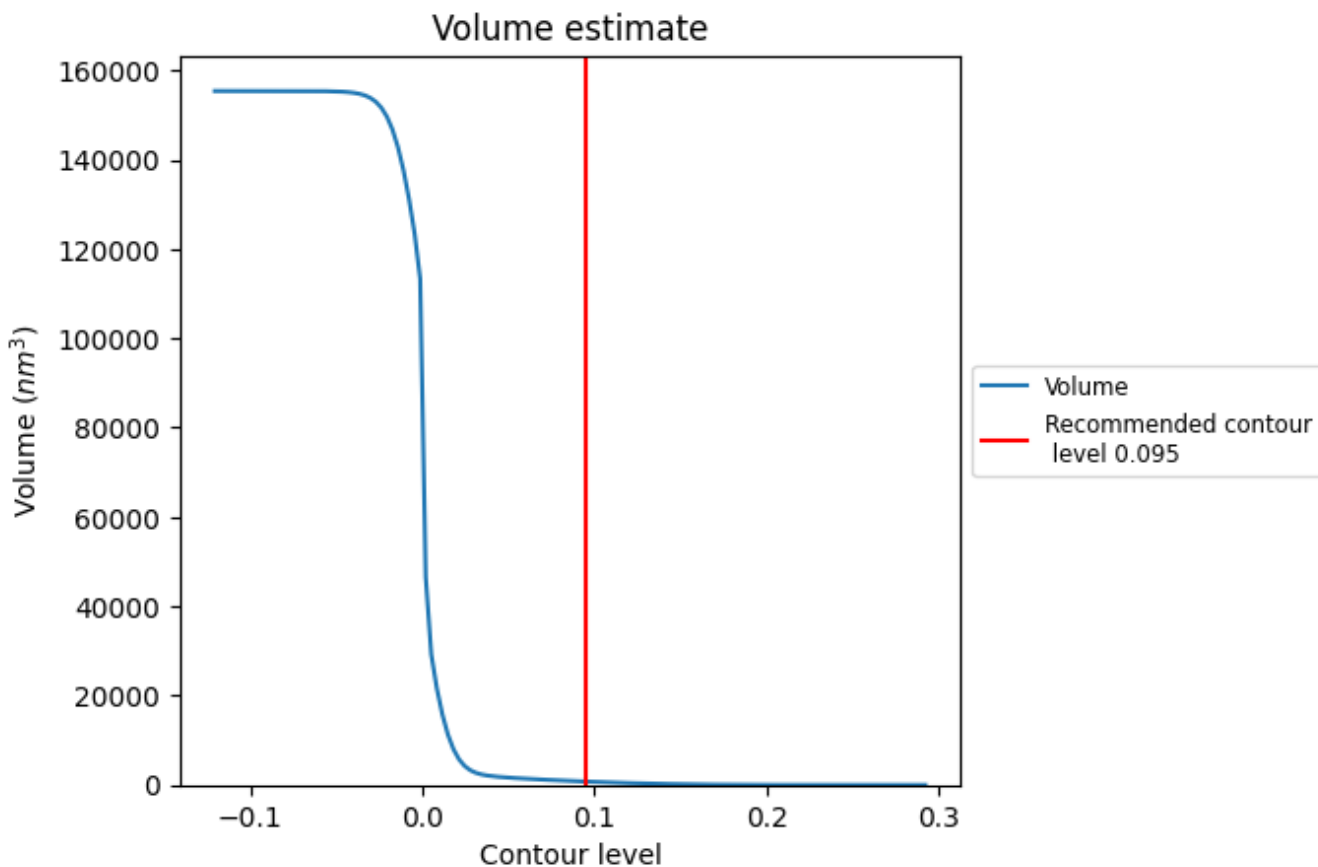

The volume at the recommended contour level is 758 nm^3 ; this corresponds to an approximate mass of 685 kDa.

The volume estimate graph shows how the enclosed volume varies with the contour level. The recommended contour level is shown as a vertical line and the intersection between the line and the curve gives the volume of the enclosed surface at the given level.

7.3 Rotationally averaged power spectrum i

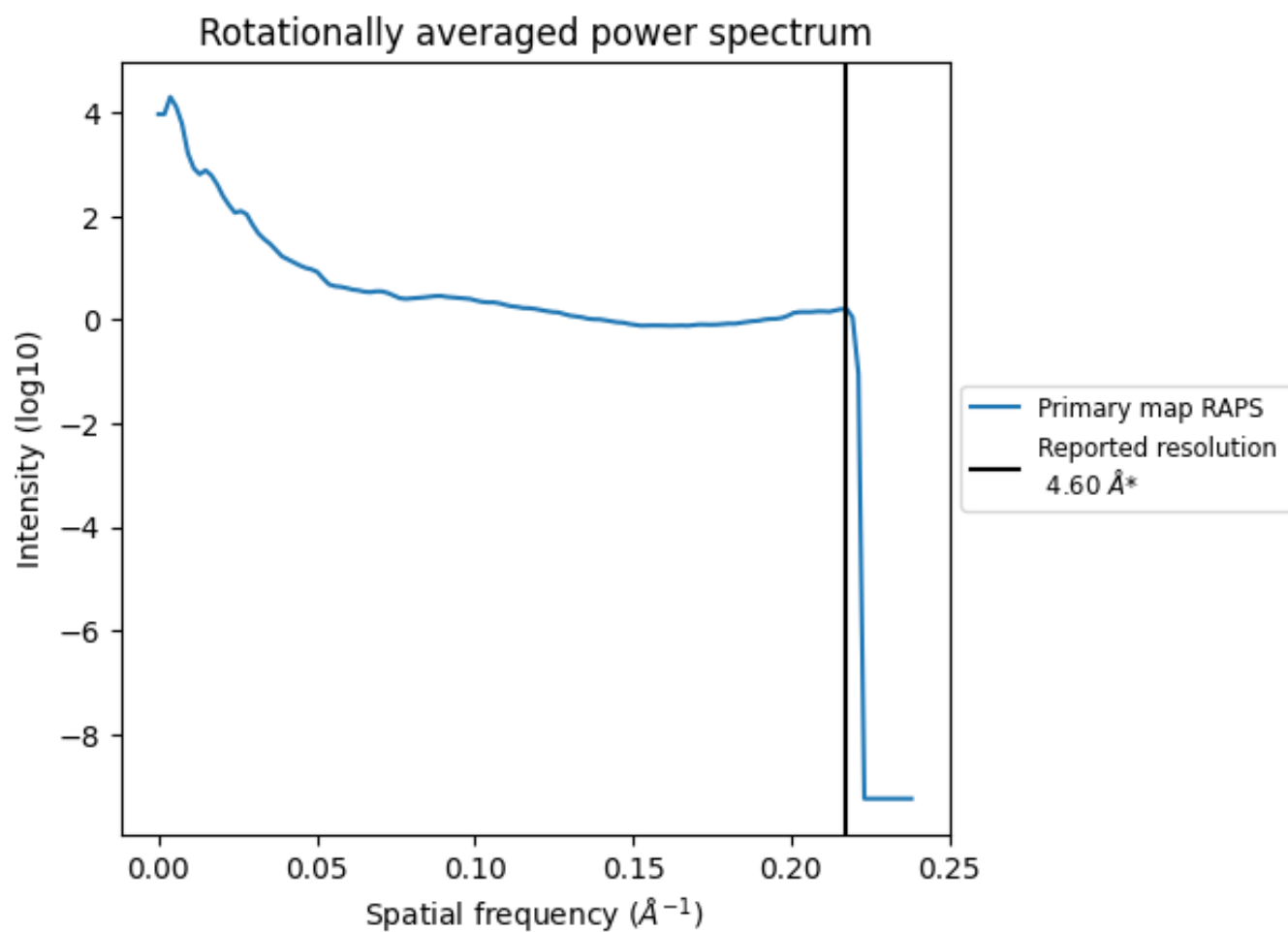

*Reported resolution corresponds to spatial frequency of 0.217 Å⁻¹

8 Fourier-Shell correlation

This section was not generated. No FSC curve or half-maps provided.

9 Map-model fit [i](#)

This section contains information regarding the fit between EMDB map EMD-6575 and PDB model 3JCP. Per-residue inclusion information can be found in section 3 on page 11.

9.1 Map-model overlay [i](#)

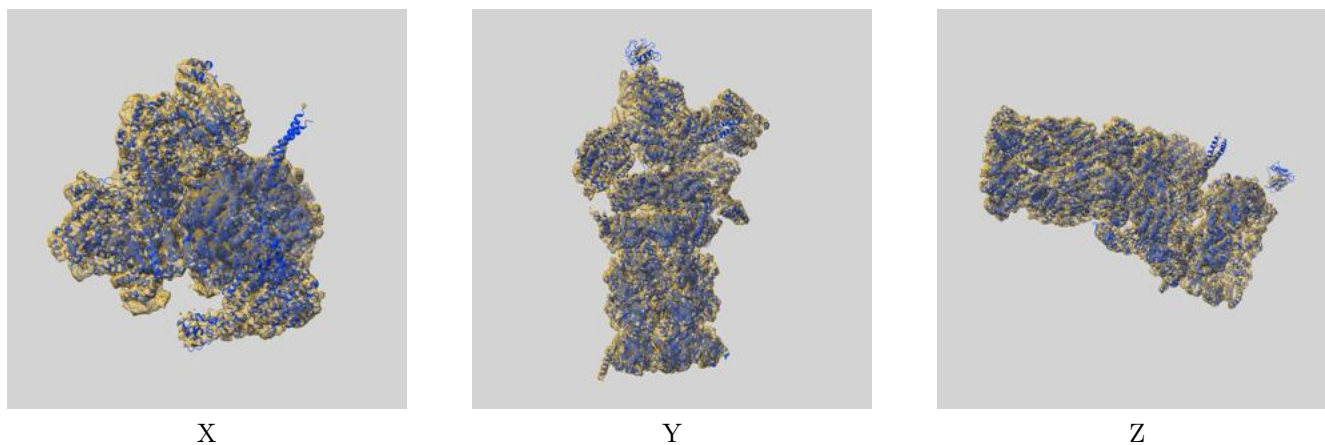

The images above show the 3D surface view of the map at the recommended contour level 0.095 at 50% transparency in yellow overlaid with a ribbon representation of the model coloured in blue. These images allow for the visual assessment of the quality of fit between the atomic model and the map.

9.2 Q-score mapped to coordinate model [i](#)

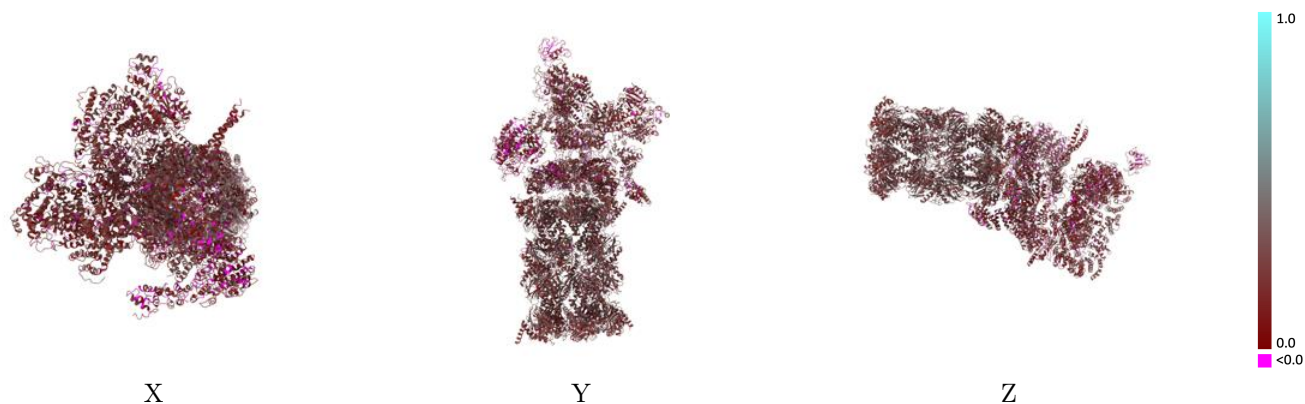

The images above show the model with each residue coloured according to its Q-score. This shows their resolvability in the map with higher Q-score values reflecting better resolvability. Please note: Q-score is calculating the resolvability of atoms, and thus high values are only expected at resolutions at which atoms can be resolved. Low Q-score values may therefore be expected for many entries.

9.3 Atom inclusion mapped to coordinate model [i](#)

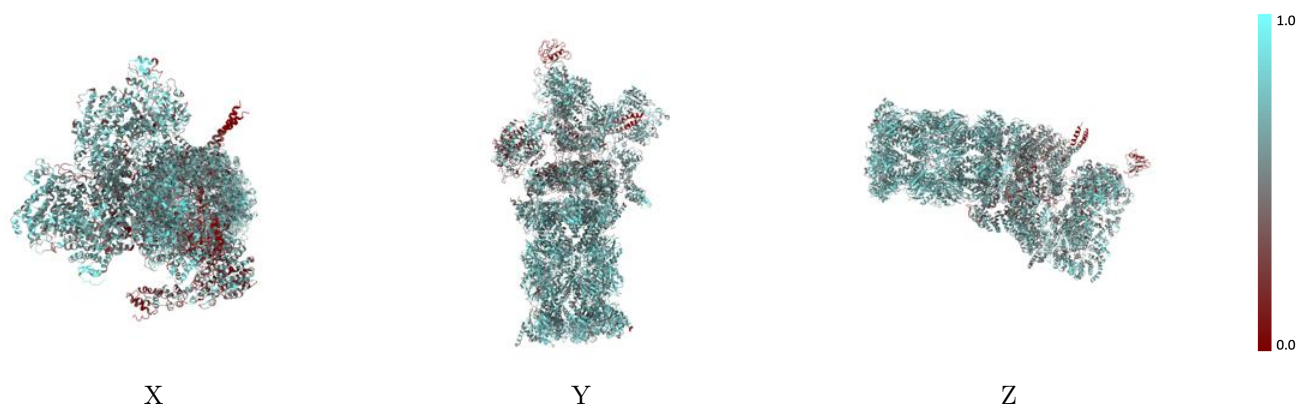

The images above show the model with each residue coloured according to its atom inclusion. This shows to what extent they are inside the map at the recommended contour level (0.095).



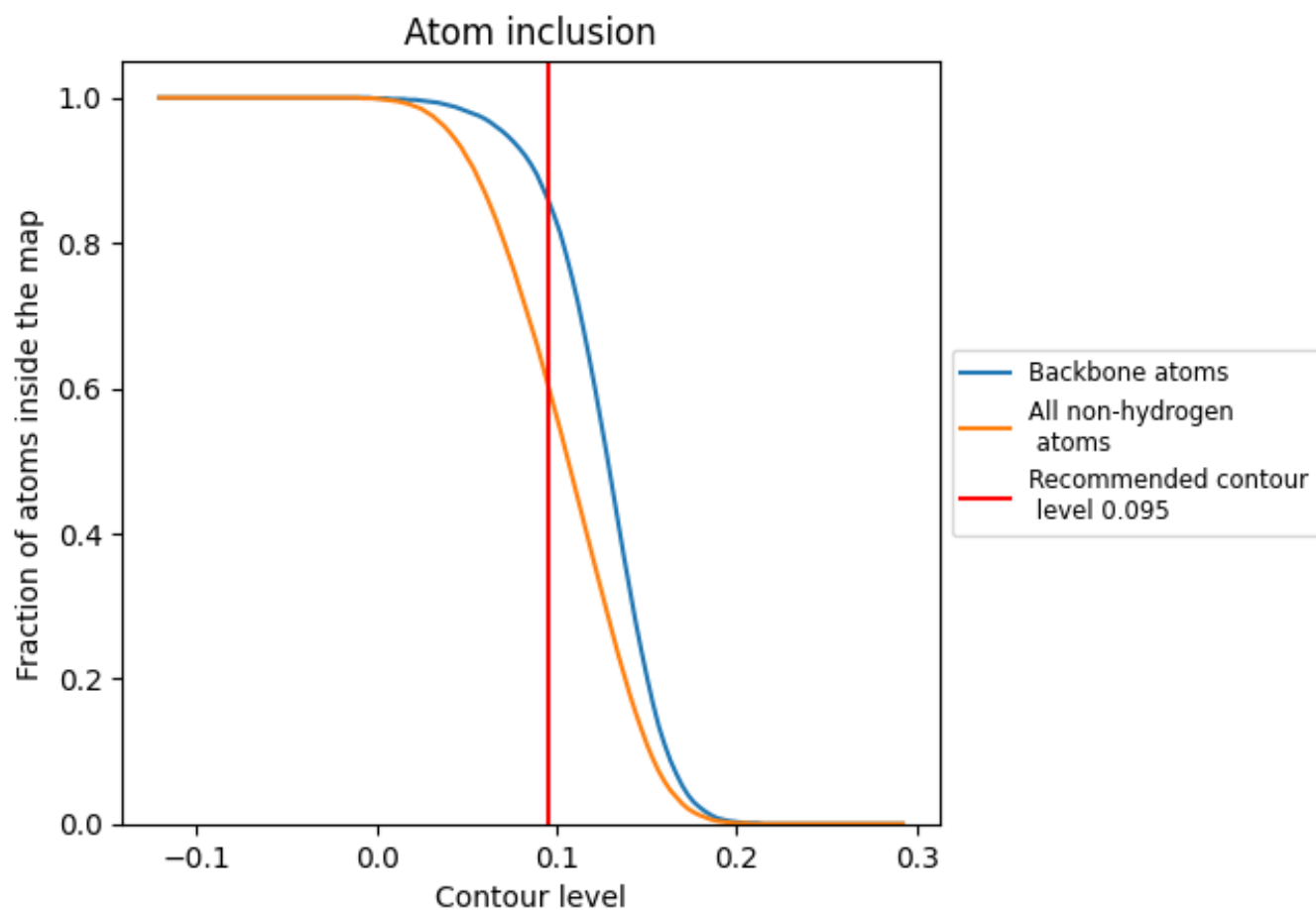



































































9.4 Atom inclusion [i](#)



At the recommended contour level, 86% of all backbone atoms, 61% of all non-hydrogen atoms, are inside the map.

9.5 Map-model fit summary





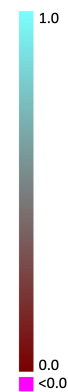





















The table lists the average atom inclusion at the recommended contour level (0.095) and Q-score for the entire model and for each chain.

Chain	Atom inclusion	Q-score
All	 0.6060	 0.2320
1	 0.6860	 0.2810
2	 0.7010	 0.2900
3	 0.7000	 0.2710
4	 0.6700	 0.2910
5	 0.6580	 0.2800
6	 0.6540	 0.2870
7	 0.7200	 0.2800
8	 0.7010	 0.2930
9	 0.6950	 0.2810
A	 0.6730	 0.2680
B	 0.6500	 0.2630
C	 0.6620	 0.2530
D	 0.6620	 0.2550
E	 0.6550	 0.2470
F	 0.6870	 0.2530
G	 0.6860	 0.2620
H	 0.5420	 0.2040
I	 0.5020	 0.1970
J	 0.4720	 0.1920
K	 0.5220	 0.2180
L	 0.5290	 0.2170
M	 0.5310	 0.2080
N	 0.6350	 0.2160
O	 0.6170	 0.1860
P	 0.6190	 0.1910
Q	 0.5470	 0.1840
R	 0.5590	 0.1890
S	 0.6110	 0.1980
T	 0.5940	 0.1930
U	 0.6260	 0.2280
V	 0.5860	 0.2200
W	 0.6070	 0.1900
X	 0.1030	 0.0880
Y	 0.5290	 0.2170



Continued on next page...

Continued from previous page...

Chain	Atom inclusion	Q-score
Z	 0.4240	 0.1300
a	 0.6470	 0.2870
b	 0.6240	 0.2890
c	 0.6070	 0.2680
d	 0.6340	 0.2620
e	 0.6150	 0.2620
f	 0.6700	 0.2800
g	 0.6640	 0.2820
h	 0.6920	 0.2850
i	 0.6880	 0.3040
j	 0.6900	 0.2980
k	 0.6750	 0.2860
l	 0.7120	 0.2810