



wwPDB X-ray Structure Validation Summary Report ⓘ

Aug 20, 2023 – 03:14 PM EDT

PDB ID : 2NX3
Title : Structural and mechanistic changes along an engineered path from metallo to non-metallo KDO8P synthase
Authors : Kona, F.; Xu, X.; Martin, P.; Kuzmic, P.; Gatti, D.L.
Deposited on : 2006-11-16
Resolution : 2.10 Å(reported)

This is a wwPDB X-ray Structure Validation Summary Report for a publicly released PDB entry.

We welcome your comments at validation@mail.wwpdb.org

A user guide is available at

<https://www.wwpdb.org/validation/2017/XrayValidationReportHelp>

with specific help available everywhere you see the ⓘ symbol.

The types of validation reports are described at

<http://www.wwpdb.org/validation/2017/FAQs#types>.

The following versions of software and data (see [references ⓘ](#)) were used in the production of this report:

MolProbity : 4.02b-467
Mogul : 1.8.5 (274361), CSD as541be (2020)
Xtriage (Phenix) : 1.13
EDS : 2.35
buster-report : 1.1.7 (2018)
Percentile statistics : 20191225.v01 (using entries in the PDB archive December 25th 2019)
Refmac : 5.8.0158
CCP4 : 7.0.044 (Gargrove)
Ideal geometry (proteins) : Engh & Huber (2001)
Ideal geometry (DNA, RNA) : Parkinson et al. (1996)
Validation Pipeline (wwPDB-VP) : 2.35

1 Overall quality at a glance

The following experimental techniques were used to determine the structure:

X-RAY DIFFRACTION

The reported resolution of this entry is 2.10 Å.

Percentile scores (ranging between 0-100) for global validation metrics of the entry are shown in the following graphic. The table shows the number of entries on which the scores are based.

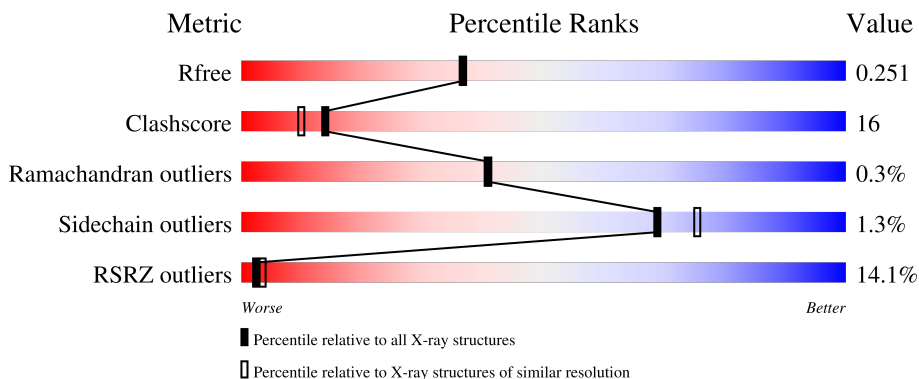







Metric	Whole archive (#Entries)	Similar resolution (#Entries, resolution range(Å))
R_{free}	130704	5197 (2.10-2.10)
Clashscore	141614	5710 (2.10-2.10)
Ramachandran outliers	138981	5647 (2.10-2.10)
Sidechain outliers	138945	5648 (2.10-2.10)
RSRZ outliers	127900	5083 (2.10-2.10)

The table below summarises the geometric issues observed across the polymeric chains and their fit to the electron density. The red, orange, yellow and green segments of the lower bar indicate the fraction of residues that contain outliers for ≥ 3 , 2, 1 and 0 types of geometric quality criteria respectively. A grey segment represents the fraction of residues that are not modelled. The numeric value for each fraction is indicated below the corresponding segment, with a dot representing fractions $\leq 5\%$. The upper red bar (where present) indicates the fraction of residues that have poor fit to the electron density. The numeric value is given above the bar.

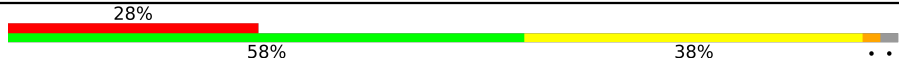
Mol	Chain	Length	Quality of chain
1	A	267	
1	B	267	
1	C	267	
1	D	267	
1	E	267	

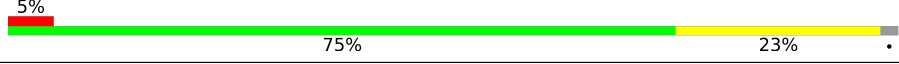
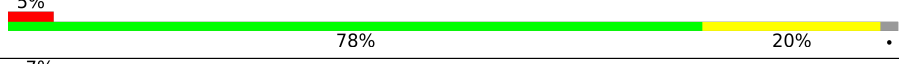
Continued on next page...

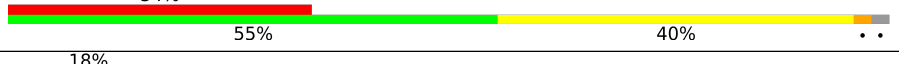
Continued from previous page...

Mol	Chain	Length	Quality of chain
1	F	267	
1	G	267	
1	H	267	
1	I	267	
1	J	267	
1	K	267	
1	L	267	

The following table lists non-polymeric compounds, carbohydrate monomers and non-standard residues in protein, DNA, RNA chains that are outliers for geometric or electron-density-fit criteria:

Mol	Type	Chain	Res	Chirality	Geometry	Clashes	Electron density
2	PEP	B	268	-	-	X	-
2	PEP	H	268	-	-	X	-
2	PEP	I	268	-	-	X	-
3	A5P	B	269	-	-	X	-

2 Entry composition [i](#)

There are 5 unique types of molecules in this entry. The entry contains 26573 atoms, of which 0 are hydrogens and 0 are deuteriums.

In the tables below, the ZeroOcc column contains the number of atoms modelled with zero occupancy, the AltConf column contains the number of residues with at least one atom in alternate conformation and the Trace column contains the number of residues modelled with at most 2 atoms.

- Molecule 1 is a protein called 2-dehydro-3-deoxyphosphooctonate aldolase.

Mol	Chain	Residues	Atoms					ZeroOcc	AltConf	Trace
			Total	C	N	O	S			
1	A	262	2055	1327	344	379	5	0	0	0
1	B	262	2055	1327	344	379	5	0	0	0
1	C	262	2055	1327	344	379	5	0	0	0
1	D	262	2055	1327	344	379	5	0	0	0
1	E	262	2055	1327	344	379	5	0	0	0
1	F	262	2055	1327	344	379	5	0	0	0
1	G	262	2055	1327	344	379	5	0	0	0
1	H	262	2055	1327	344	379	5	0	0	0
1	I	262	2055	1327	344	379	5	0	0	0
1	J	262	2055	1327	344	379	5	0	0	0
1	K	262	2055	1327	344	379	5	0	0	0
1	L	262	2055	1327	344	379	5	0	0	0

There are 36 discrepancies between the modelled and reference sequences:

Chain	Residue	Modelled	Actual	Comment	Reference
A	11	ASN	CYS	engineered mutation	UNP O66496
A	235	PRO	SER	engineered mutation	UNP O66496
A	237	ALA	GLN	engineered mutation	UNP O66496
B	11	ASN	CYS	engineered mutation	UNP O66496
B	235	PRO	SER	engineered mutation	UNP O66496

Continued on next page...

Continued from previous page...

Chain	Residue	Modelled	Actual	Comment	Reference
B	237	ALA	GLN	engineered mutation	UNP O66496
C	11	ASN	CYS	engineered mutation	UNP O66496
C	235	PRO	SER	engineered mutation	UNP O66496
C	237	ALA	GLN	engineered mutation	UNP O66496
D	11	ASN	CYS	engineered mutation	UNP O66496
D	235	PRO	SER	engineered mutation	UNP O66496
D	237	ALA	GLN	engineered mutation	UNP O66496
E	11	ASN	CYS	engineered mutation	UNP O66496
E	235	PRO	SER	engineered mutation	UNP O66496
E	237	ALA	GLN	engineered mutation	UNP O66496
F	11	ASN	CYS	engineered mutation	UNP O66496
F	235	PRO	SER	engineered mutation	UNP O66496
F	237	ALA	GLN	engineered mutation	UNP O66496
G	11	ASN	CYS	engineered mutation	UNP O66496
G	235	PRO	SER	engineered mutation	UNP O66496
G	237	ALA	GLN	engineered mutation	UNP O66496
H	11	ASN	CYS	engineered mutation	UNP O66496
H	235	PRO	SER	engineered mutation	UNP O66496
H	237	ALA	GLN	engineered mutation	UNP O66496
I	11	ASN	CYS	engineered mutation	UNP O66496
I	235	PRO	SER	engineered mutation	UNP O66496
I	237	ALA	GLN	engineered mutation	UNP O66496
J	11	ASN	CYS	engineered mutation	UNP O66496
J	235	PRO	SER	engineered mutation	UNP O66496
J	237	ALA	GLN	engineered mutation	UNP O66496
K	11	ASN	CYS	engineered mutation	UNP O66496
K	235	PRO	SER	engineered mutation	UNP O66496
K	237	ALA	GLN	engineered mutation	UNP O66496
L	11	ASN	CYS	engineered mutation	UNP O66496
L	235	PRO	SER	engineered mutation	UNP O66496
L	237	ALA	GLN	engineered mutation	UNP O66496

- Molecule 2 is PHOSPHOENOLPYRUVATE (three-letter code: PEP) (formula: C₃H₅O₆P).

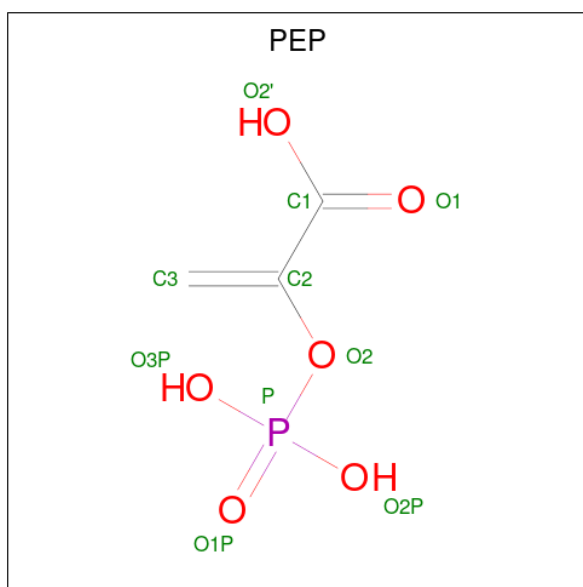

Mol	Chain	Residues	Atoms				ZeroOcc	AltConf
			Total	C	O	P		
2	A	1	Total 10	C 3	O 6	P 1	0	0
2	B	1	Total 10	C 3	O 6	P 1	0	0
2	C	1	Total 10	C 3	O 6	P 1	0	0
2	E	1	Total 10	C 3	O 6	P 1	0	0
2	F	1	Total 10	C 3	O 6	P 1	0	0
2	G	1	Total 10	C 3	O 6	P 1	0	0
2	H	1	Total 10	C 3	O 6	P 1	0	0
2	I	1	Total 10	C 3	O 6	P 1	0	0
2	J	1	Total 10	C 3	O 6	P 1	0	0
2	K	1	Total 10	C 3	O 6	P 1	0	0
2	L	1	Total 10	C 3	O 6	P 1	0	0

- Molecule 3 is ARABINOSE-5-PHOSPHATE (three-letter code: A5P) (formula: C₅H₁₃O₈P).

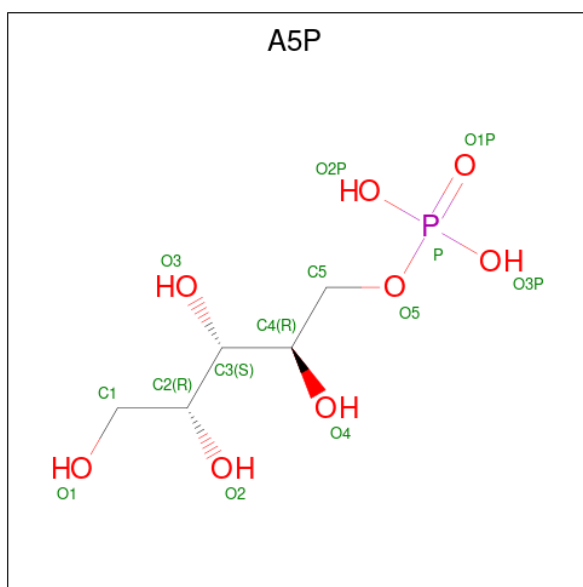

Mol	Chain	Residues	Atoms				ZeroOcc	AltConf
			Total	C	O	P		
3	A	1	Total 14	C 5	O 8	P 1	0	0
3	B	1	Total 14	C 5	O 8	P 1	0	0
3	C	1	Total 14	C 5	O 8	P 1	0	0
3	E	1	Total 14	C 5	O 8	P 1	0	0
3	F	1	Total 14	C 5	O 8	P 1	0	0
3	G	1	Total 14	C 5	O 8	P 1	0	0
3	H	1	Total 14	C 5	O 8	P 1	0	0
3	I	1	Total 14	C 5	O 8	P 1	0	0
3	J	1	Total 14	C 5	O 8	P 1	0	0
3	K	1	Total 14	C 5	O 8	P 1	0	0
3	L	1	Total 14	C 5	O 8	P 1	0	0

- Molecule 4 is (2R,4R,5R,6R,7R)-2,4,5,6,7-PENTAHYDROXY-2,8-BIS(PHOSPHONOXY)OCTANOIC ACID (three-letter code: 1NT) (formula: C₈H₁₈O₁₅P₂).

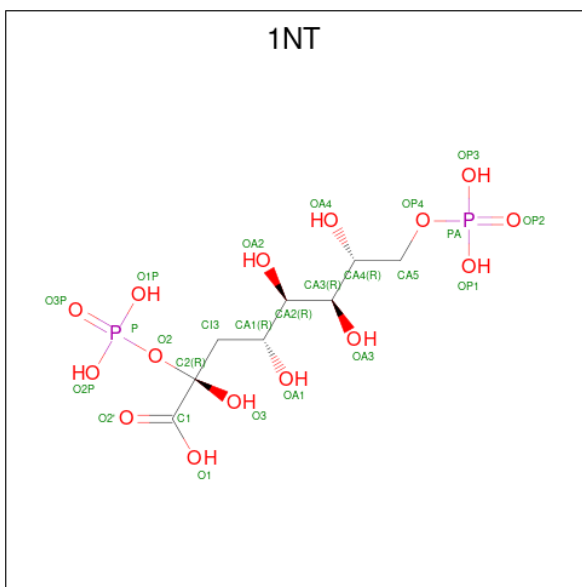

Mol	Chain	Residues	Atoms				ZeroOcc	AltConf
4	D	1	Total	C	O	P	0	0
			25	8	15	2		

- Molecule 5 is water.

Mol	Chain	Residues	Atoms		ZeroOcc	AltConf
5	A	194	Total	O	0	0
			194	194		
5	B	197	Total	O	0	0
			197	197		
5	C	108	Total	O	0	0
			108	108		
5	D	88	Total	O	0	0
			88	88		
5	E	71	Total	O	0	0
			71	71		
5	F	55	Total	O	0	0
			55	55		
5	G	177	Total	O	0	0
			177	177		
5	H	191	Total	O	0	0
			191	191		
5	I	191	Total	O	0	0
			191	191		
5	J	184	Total	O	0	0
			184	184		
5	K	56	Total	O	0	0
			56	56		

Continued on next page...

Continued from previous page...

Mol	Chain	Residues	Atoms		ZeroOcc	AltConf
5	L	112	Total 112	O 112	0	0

3 Residue-property plots [i](#)

These plots are drawn for all protein, RNA, DNA and oligosaccharide chains in the entry. The first graphic for a chain summarises the proportions of the various outlier classes displayed in the second graphic. The second graphic shows the sequence view annotated by issues in geometry and electron density. Residues are color-coded according to the number of geometric quality criteria for which they contain at least one outlier: green = 0, yellow = 1, orange = 2 and red = 3 or more. A red dot above a residue indicates a poor fit to the electron density ($RSRZ > 2$). Stretches of 2 or more consecutive residues without any outlier are shown as a green connector. Residues present in the sample, but not in the model, are shown in grey.

- Molecule 1: 2-dehydro-3-deoxyphosphooctonate aldolase

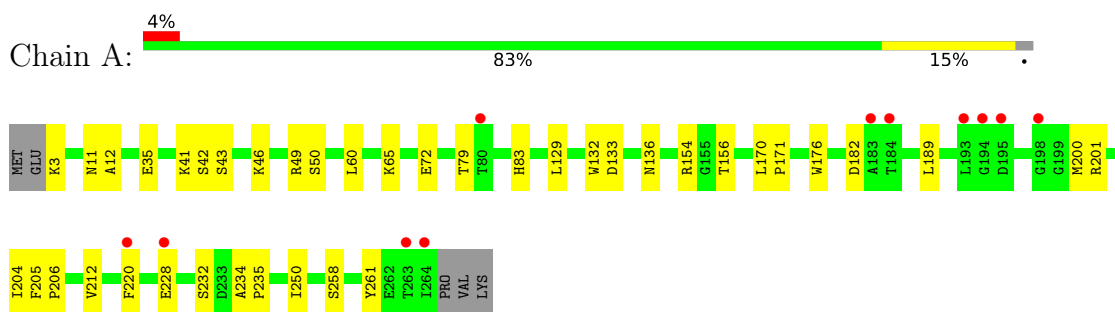

- Molecule 1: 2-dehydro-3-deoxyphosphooctonate aldolase

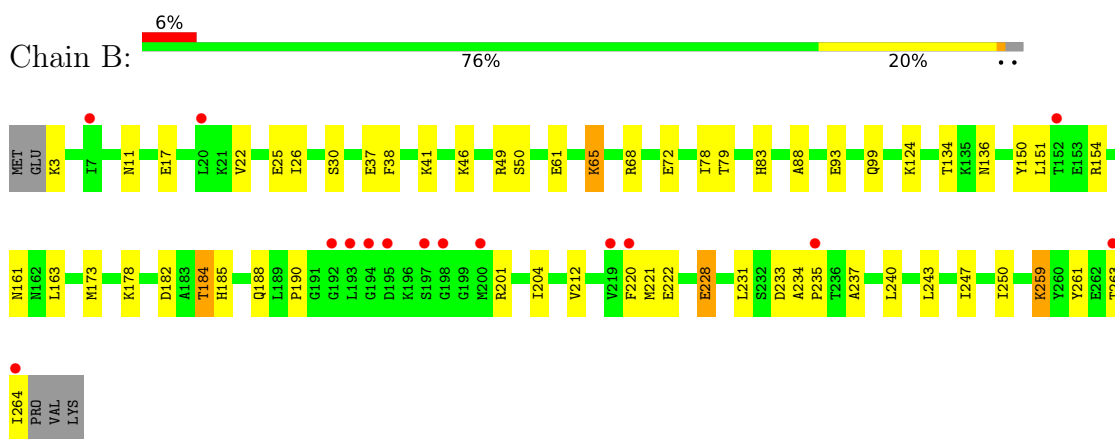

- Molecule 1: 2-dehydro-3-deoxyphosphooctonate aldolase

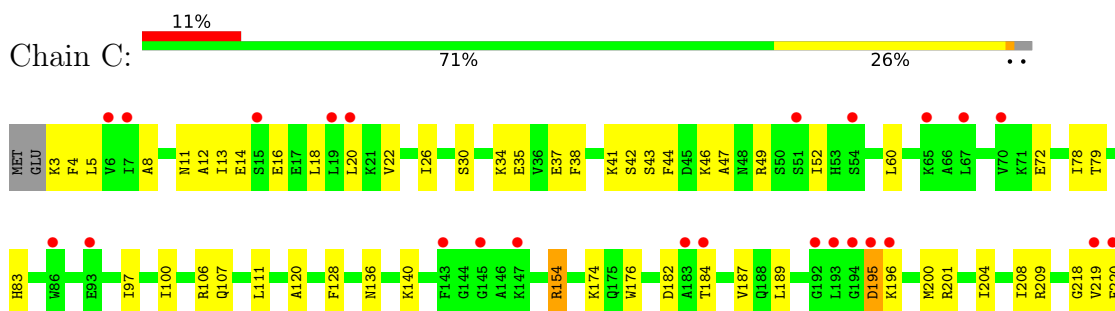

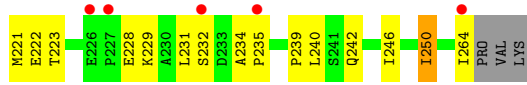

● Molecule 1: 2-dehydro-3-deoxyphosphooctonate aldolase

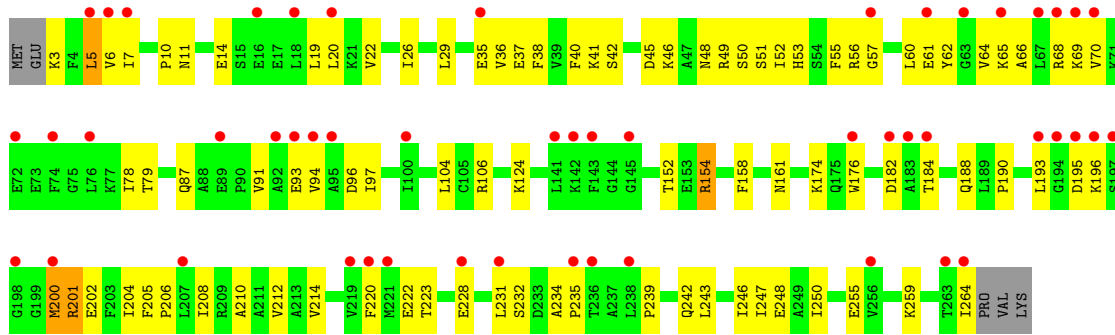

● Molecule 1: 2-dehydro-3-deoxyphosphooctonate aldolase

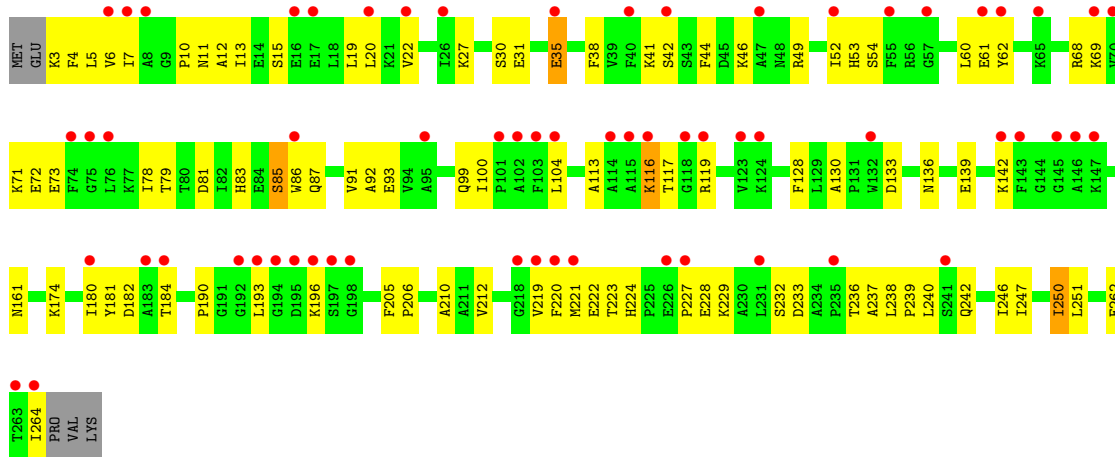

● Molecule 1: 2-dehydro-3-deoxyphosphooctonate aldolase

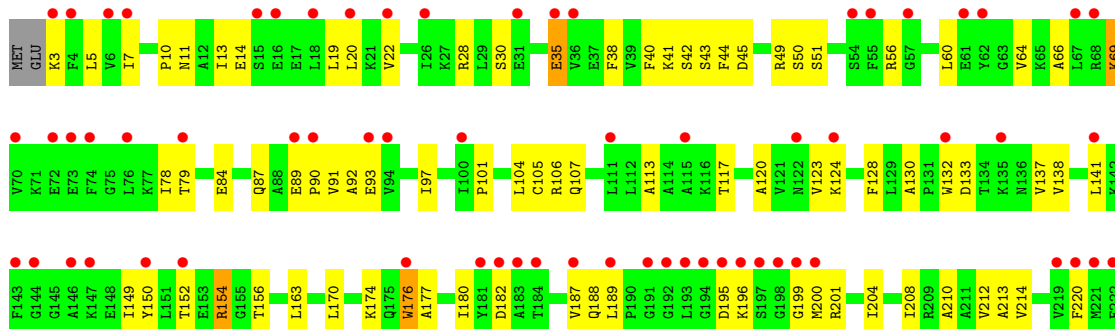



- Molecule 1: 2-dehydro-3-deoxyphosphooctonate aldolase

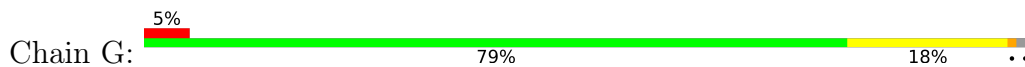

- Molecule 1: 2-dehydro-3-deoxyphosphooctonate aldolase

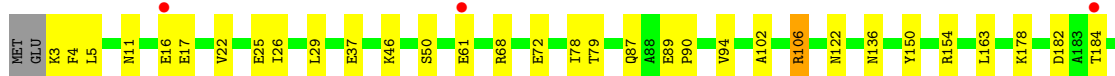
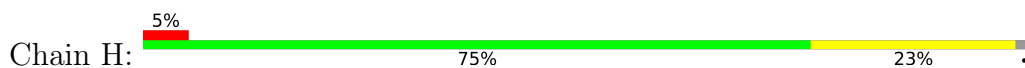

- Molecule 1: 2-dehydro-3-deoxyphosphooctonate aldolase

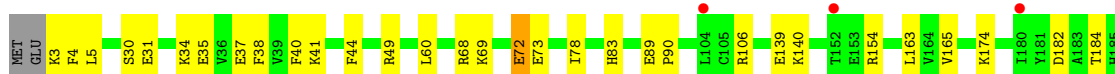
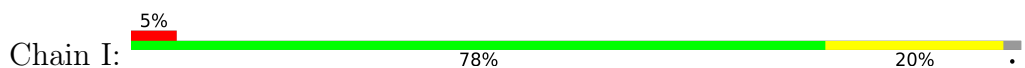

- Molecule 1: 2-dehydro-3-deoxyphosphooctonate aldolase

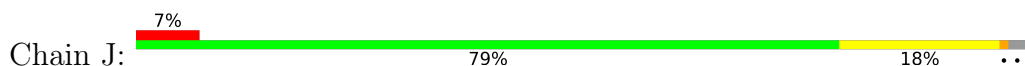

- Molecule 1: 2-dehydro-3-deoxyphosphooctonate aldolase



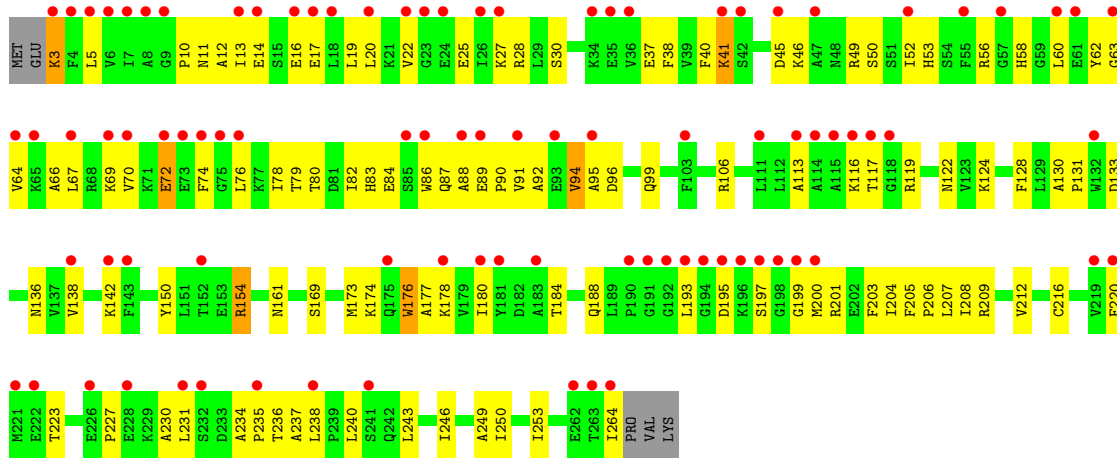

● Molecule 1: 2-dehydro-3-deoxyphosphooctonate aldolase

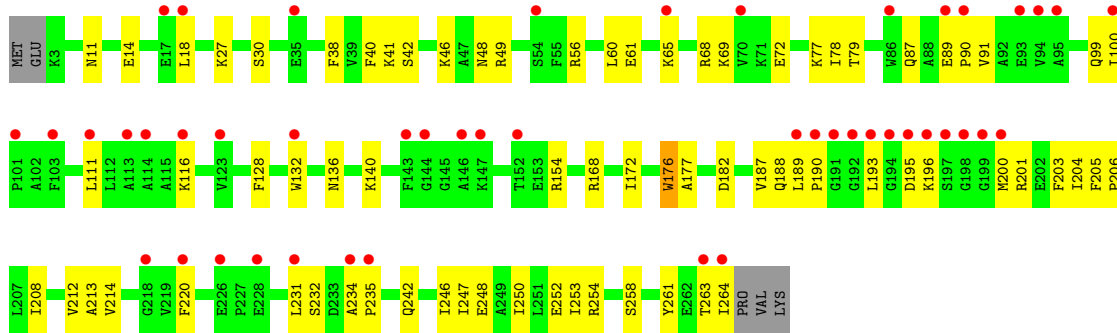

4 Data and refinement statistics

Property	Value	Source
Space group	P 1 21 1	Depositor
Cell constants a, b, c, α , β , γ	76.38Å 198.53Å 125.83Å 90.00° 94.19° 90.00°	Depositor
Resolution (Å)	29.79 – 2.10 29.79 – 2.10	Depositor EDS
% Data completeness (in resolution range)	94.9 (29.79-2.10) 94.6 (29.79-2.10)	Depositor EDS
R_{merge}	0.07	Depositor
R_{sym}	0.07	Depositor
$\langle I/\sigma(I) \rangle$ ¹	1.92 (at 2.10Å)	Xtrriage
Refinement program	CNS 1.1	Depositor
R, R_{free}	0.216 , 0.261 0.206 , 0.251	Depositor DCC
R_{free} test set	20582 reflections (9.53%)	wwPDB-VP
Wilson B-factor (Å ²)	29.8	Xtrriage
Anisotropy	0.707	Xtrriage
Bulk solvent k_{sol} (e/Å ³), B_{sol} (Å ²)	0.33 , 58.2	EDS
L-test for twinning ²	$\langle L \rangle = 0.45$, $\langle L^2 \rangle = 0.28$	Xtrriage
Estimated twinning fraction	No twinning to report.	Xtrriage
F_o, F_c correlation	0.95	EDS
Total number of atoms	26573	wwPDB-VP
Average B, all atoms (Å ²)	43.0	wwPDB-VP

Xtrriage's analysis on translational NCS is as follows: *The analyses of the Patterson function reveals a significant off-origin peak that is 19.98 % of the origin peak, indicating pseudo-translational symmetry. The chance of finding a peak of this or larger height randomly in a structure without pseudo-translational symmetry is equal to 9.6054e-03. The detected translational NCS is most likely also responsible for the elevated intensity ratio.*

¹Intensities estimated from amplitudes.

²Theoretical values of $\langle |L| \rangle$, $\langle L^2 \rangle$ for acentric reflections are 0.5, 0.333 respectively for untwinned datasets, and 0.375, 0.2 for perfectly twinned datasets.

5 Model quality

5.1 Standard geometry

Bond lengths and bond angles in the following residue types are not validated in this section: A5P, PEP, 1NT

The Z score for a bond length (or angle) is the number of standard deviations the observed value is removed from the expected value. A bond length (or angle) with $|Z| > 5$ is considered an outlier worth inspection. RMSZ is the root-mean-square of all Z scores of the bond lengths (or angles).

Mol	Chain	Bond lengths		Bond angles	
		RMSZ	# Z >5	RMSZ	# Z >5
1	A	0.42	1/2097 (0.0%)	0.61	0/2830
1	B	0.39	0/2097	0.62	0/2830
1	C	0.36	1/2097 (0.0%)	0.55	0/2830
1	D	0.32	0/2097	0.55	0/2830
1	E	0.35	1/2097 (0.0%)	0.52	0/2830
1	F	0.30	0/2097	0.52	0/2830
1	G	0.39	1/2097 (0.0%)	0.60	0/2830
1	H	0.38	0/2097	0.61	0/2830
1	I	0.42	1/2097 (0.0%)	0.60	0/2830
1	J	0.37	0/2097	0.60	0/2830
1	K	0.33	1/2097 (0.0%)	0.52	0/2830
1	L	0.32	0/2097	0.54	0/2830
All	All	0.36	6/25164 (0.0%)	0.57	0/33960

The worst 5 of 6 bond length outliers are listed below:

Mol	Chain	Res	Type	Atoms	Z	Observed(Å)	Ideal(Å)
1	A	72	GLU	CD-OE2	7.44	1.33	1.25
1	E	72	GLU	CD-OE2	7.12	1.33	1.25
1	K	72	GLU	CD-OE2	7.11	1.33	1.25
1	G	72	GLU	CD-OE2	6.99	1.33	1.25
1	C	72	GLU	CD-OE2	6.97	1.33	1.25

There are no bond angle outliers.

There are no chirality outliers.

There are no planarity outliers.

5.2 Too-close contacts

In the following table, the Non-H and H(model) columns list the number of non-hydrogen atoms and hydrogen atoms in the chain respectively. The H(added) column lists the number of hydrogen atoms added and optimized by MolProbity. The Clashes column lists the number of clashes within the asymmetric unit, whereas Symm-Clashes lists symmetry-related clashes.

Mol	Chain	Non-H	H(model)	H(added)	Clashes	Symm-Clashes
1	A	2055	0	2095	34	0
1	B	2055	0	2095	58	0
1	C	2055	0	2095	62	0
1	D	2055	0	2095	75	0
1	E	2055	0	2095	78	0
1	F	2055	0	2095	101	0
1	G	2055	0	2095	45	0
1	H	2055	0	2095	69	0
1	I	2055	0	2095	53	0
1	J	2055	0	2095	56	0
1	K	2055	0	2095	108	0
1	L	2055	0	2095	66	0
2	A	10	0	2	2	0
2	B	10	0	2	4	0
2	C	10	0	2	2	0
2	E	10	0	2	1	0
2	F	10	0	2	2	0
2	G	10	0	2	1	0
2	H	10	0	2	5	0
2	I	10	0	2	5	0
2	J	10	0	2	3	0
2	K	10	0	2	2	0
2	L	10	0	2	2	0
3	A	14	0	10	2	0
3	B	14	0	10	6	0
3	C	14	0	10	3	0
3	E	14	0	10	0	0
3	F	14	0	10	4	0
3	G	14	0	10	3	0
3	H	14	0	10	3	0
3	I	14	0	10	3	0
3	J	14	0	10	2	0
3	K	14	0	10	1	0
3	L	14	0	10	1	0
4	D	25	0	13	4	0
5	A	194	0	0	4	0
5	B	197	0	0	10	0

Continued on next page...

Continued from previous page...

Mol	Chain	Non-H	H(model)	H(added)	Clashes	Symm-Clashes
5	C	108	0	0	6	0
5	D	88	0	0	10	0
5	E	71	0	0	6	0
5	F	55	0	0	5	0
5	G	177	0	0	8	0
5	H	191	0	0	12	0
5	I	191	0	0	12	0
5	J	184	0	0	10	0
5	K	56	0	0	12	0
5	L	112	0	0	9	0
All	All	26573	0	25285	794	0

The all-atom clashscore is defined as the number of clashes found per 1000 atoms (including hydrogen atoms). The all-atom clashscore for this structure is 16.

The worst 5 of 794 close contacts within the same asymmetric unit are listed below, sorted by their clash magnitude.

Atom-1	Atom-2	Interatomic distance (Å)	Clash overlap (Å)
1:H:184:THR:HG21	1:H:222:GLU:H	1.15	1.12
1:B:184:THR:HG21	1:B:222:GLU:H	1.17	1.06
1:B:151:LEU:HB3	1:B:173:MET:HE1	1.37	1.04
1:I:154:ARG:HH22	1:I:188:GLN:NE2	1.62	0.98
1:D:212:VAL:HG11	1:D:250:ILE:HG23	1.47	0.96

There are no symmetry-related clashes.

5.3 Torsion angles [i](#)

5.3.1 Protein backbone [i](#)

In the following table, the Percentiles column shows the percent Ramachandran outliers of the chain as a percentile score with respect to all X-ray entries followed by that with respect to entries of similar resolution.

The Analysed column shows the number of residues for which the backbone conformation was analysed, and the total number of residues.

Mol	Chain	Analysed	Favoured	Allowed	Outliers	Percentiles
1	A	260/267 (97%)	253 (97%)	7 (3%)	0	100 100
1	B	260/267 (97%)	253 (97%)	7 (3%)	0	100 100

Continued on next page...

Continued from previous page...

Mol	Chain	Analysed	Favoured	Allowed	Outliers	Percentiles	
1	C	260/267 (97%)	245 (94%)	15 (6%)	0	100	100
1	D	260/267 (97%)	246 (95%)	14 (5%)	0	100	100
1	E	260/267 (97%)	241 (93%)	15 (6%)	4 (2%)	10	5
1	F	260/267 (97%)	235 (90%)	22 (8%)	3 (1%)	13	8
1	G	260/267 (97%)	253 (97%)	7 (3%)	0	100	100
1	H	260/267 (97%)	251 (96%)	9 (4%)	0	100	100
1	I	260/267 (97%)	252 (97%)	8 (3%)	0	100	100
1	J	260/267 (97%)	249 (96%)	10 (4%)	1 (0%)	34	32
1	K	260/267 (97%)	237 (91%)	22 (8%)	1 (0%)	34	32
1	L	260/267 (97%)	246 (95%)	14 (5%)	0	100	100
All	All	3120/3204 (97%)	2961 (95%)	150 (5%)	9 (0%)	41	41

5 of 9 Ramachandran outliers are listed below:

Mol	Chain	Res	Type
1	E	86	TRP
1	E	92	ALA
1	F	92	ALA
1	K	94	VAL
1	F	105	CYS

5.3.2 Protein sidechains [i](#)

In the following table, the Percentiles column shows the percent sidechain outliers of the chain as a percentile score with respect to all X-ray entries followed by that with respect to entries of similar resolution.

The Analysed column shows the number of residues for which the sidechain conformation was analysed, and the total number of residues.

Mol	Chain	Analysed	Rotameric	Outliers	Percentiles	
1	A	218/223 (98%)	217 (100%)	1 (0%)	88	92
1	B	218/223 (98%)	214 (98%)	4 (2%)	59	65
1	C	218/223 (98%)	214 (98%)	4 (2%)	59	65
1	D	218/223 (98%)	213 (98%)	5 (2%)	50	55
1	E	218/223 (98%)	214 (98%)	4 (2%)	59	65
1	F	218/223 (98%)	212 (97%)	6 (3%)	43	47

Continued on next page...

Continued from previous page...

Mol	Chain	Analysed	Rotameric	Outliers	Percentiles	
1	G	218/223 (98%)	216 (99%)	2 (1%)	78	84
1	H	218/223 (98%)	217 (100%)	1 (0%)	88	92
1	I	218/223 (98%)	217 (100%)	1 (0%)	88	92
1	J	218/223 (98%)	217 (100%)	1 (0%)	88	92
1	K	218/223 (98%)	214 (98%)	4 (2%)	59	65
1	L	218/223 (98%)	216 (99%)	2 (1%)	78	84
All	All	2616/2676 (98%)	2581 (99%)	35 (1%)	69	75

5 of 35 residues with a non-rotameric sidechain are listed below:

Mol	Chain	Res	Type
1	J	184	THR
1	K	3	LYS
1	K	176	TRP
1	D	200	MET
1	D	176	TRP

Sometimes sidechains can be flipped to improve hydrogen bonding and reduce clashes. 5 of 59 such sidechains are listed below:

Mol	Chain	Res	Type
1	F	242	GLN
1	L	83	HIS
1	H	83	HIS
1	L	11	ASN
1	K	11	ASN

5.3.3 RNA [i](#)

There are no RNA molecules in this entry.

5.4 Non-standard residues in protein, DNA, RNA chains [i](#)

There are no non-standard protein/DNA/RNA residues in this entry.

5.5 Carbohydrates [i](#)

There are no monosaccharides in this entry.

5.6 Ligand geometry

23 ligands are modelled in this entry.

In the following table, the Counts columns list the number of bonds (or angles) for which Mogul statistics could be retrieved, the number of bonds (or angles) that are observed in the model and the number of bonds (or angles) that are defined in the Chemical Component Dictionary. The Link column lists molecule types, if any, to which the group is linked. The Z score for a bond length (or angle) is the number of standard deviations the observed value is removed from the expected value. A bond length (or angle) with $|Z| > 2$ is considered an outlier worth inspection. RMSZ is the root-mean-square of all Z scores of the bond lengths (or angles).

Mol	Type	Chain	Res	Link	Bond lengths			Bond angles		
					Counts	RMSZ	# Z > 2	Counts	RMSZ	# Z > 2
3	A5P	C	269	-	13,13,13	1.74	2 (15%)	18,18,18	1.43	2 (11%)
2	PEP	B	268	-	9,9,9	2.06	2 (22%)	11,13,13	1.26	2 (18%)
3	A5P	K	269	-	13,13,13	1.73	2 (15%)	18,18,18	1.40	2 (11%)
3	A5P	J	269	-	13,13,13	1.73	2 (15%)	18,18,18	1.39	3 (16%)
2	PEP	A	268	-	9,9,9	2.12	2 (22%)	11,13,13	1.42	2 (18%)
2	PEP	L	268	-	9,9,9	2.08	2 (22%)	11,13,13	1.38	2 (18%)
3	A5P	E	269	-	13,13,13	1.73	2 (15%)	18,18,18	1.38	2 (11%)
3	A5P	B	269	-	13,13,13	1.73	2 (15%)	18,18,18	1.38	2 (11%)
3	A5P	I	269	-	13,13,13	1.73	2 (15%)	18,18,18	1.45	2 (11%)
3	A5P	F	269	-	13,13,13	1.73	2 (15%)	18,18,18	1.35	2 (11%)
2	PEP	F	268	-	9,9,9	2.11	2 (22%)	11,13,13	1.40	2 (18%)
2	PEP	K	268	-	9,9,9	2.08	2 (22%)	11,13,13	1.37	2 (18%)
3	A5P	G	269	-	13,13,13	1.73	2 (15%)	18,18,18	1.43	2 (11%)
3	A5P	H	269	-	13,13,13	1.73	2 (15%)	18,18,18	1.35	1 (5%)
4	1NT	D	268	-	23,24,24	1.29	2 (8%)	27,37,37	1.16	2 (7%)
2	PEP	C	268	-	9,9,9	2.09	2 (22%)	11,13,13	1.37	2 (18%)
2	PEP	I	268	-	9,9,9	2.07	2 (22%)	11,13,13	1.33	2 (18%)
2	PEP	J	268	-	9,9,9	2.10	2 (22%)	11,13,13	1.31	2 (18%)
3	A5P	A	269	-	13,13,13	1.74	2 (15%)	18,18,18	1.40	2 (11%)
2	PEP	E	268	-	9,9,9	2.08	2 (22%)	11,13,13	1.41	2 (18%)
3	A5P	L	269	-	13,13,13	1.74	2 (15%)	18,18,18	1.39	2 (11%)
2	PEP	G	268	-	9,9,9	2.12	2 (22%)	11,13,13	1.40	2 (18%)
2	PEP	H	268	-	9,9,9	2.11	2 (22%)	11,13,13	1.40	2 (18%)

In the following table, the Chirals column lists the number of chiral outliers, the number of chiral centers analysed, the number of these observed in the model and the number defined in the

Chemical Component Dictionary. Similar counts are reported in the Torsion and Rings columns. '-' means no outliers of that kind were identified.

Mol	Type	Chain	Res	Link	Chirals	Torsions	Rings
3	A5P	C	269	-	-	4/16/16/16	-
2	PEP	B	268	-	-	0/9/9/9	-
3	A5P	K	269	-	-	5/16/16/16	-
3	A5P	J	269	-	-	3/16/16/16	-
2	PEP	A	268	-	-	0/9/9/9	-
2	PEP	L	268	-	-	0/9/9/9	-
3	A5P	E	269	-	-	5/16/16/16	-
3	A5P	B	269	-	-	5/16/16/16	-
3	A5P	I	269	-	-	3/16/16/16	-
3	A5P	F	269	-	-	5/16/16/16	-
2	PEP	F	268	-	-	0/9/9/9	-
2	PEP	K	268	-	-	0/9/9/9	-
3	A5P	G	269	-	-	5/16/16/16	-
3	A5P	H	269	-	-	5/16/16/16	-
4	1NT	D	268	-	-	9/30/35/35	-
2	PEP	C	268	-	-	0/9/9/9	-
2	PEP	I	268	-	-	0/9/9/9	-
2	PEP	J	268	-	-	0/9/9/9	-
3	A5P	A	269	-	-	5/16/16/16	-
2	PEP	E	268	-	-	0/9/9/9	-
3	A5P	L	269	-	-	5/16/16/16	-
2	PEP	G	268	-	-	0/9/9/9	-
2	PEP	H	268	-	-	0/9/9/9	-

The worst 5 of 46 bond length outliers are listed below:

Mol	Chain	Res	Type	Atoms	Z	Observed(Å)	Ideal(Å)
3	L	269	A5P	O1-C1	-4.51	1.23	1.42
3	I	269	A5P	O1-C1	-4.51	1.23	1.42
3	C	269	A5P	O1-C1	-4.51	1.23	1.42
3	F	269	A5P	O1-C1	-4.50	1.23	1.42
3	J	269	A5P	O1-C1	-4.50	1.23	1.42

The worst 5 of 46 bond angle outliers are listed below:

Mol	Chain	Res	Type	Atoms	Z	Observed(°)	Ideal(°)
3	A	269	A5P	O1-C1-C2	4.67	121.24	111.07
3	E	269	A5P	O1-C1-C2	4.60	121.11	111.07

Continued on next page...

Continued from previous page...

Mol	Chain	Res	Type	Atoms	Z	Observed(°)	Ideal(°)
3	G	269	A5P	O1-C1-C2	4.59	121.07	111.07
3	L	269	A5P	O1-C1-C2	4.51	120.89	111.07
3	K	269	A5P	O1-C1-C2	4.49	120.87	111.07

There are no chirality outliers.

5 of 59 torsion outliers are listed below:

Mol	Chain	Res	Type	Atoms
3	A	269	A5P	C5-O5-P-O3P
3	B	269	A5P	C5-O5-P-O1P
3	B	269	A5P	C5-O5-P-O2P
3	B	269	A5P	C5-O5-P-O3P
3	C	269	A5P	C5-O5-P-O2P

There are no ring outliers.

22 monomers are involved in 51 short contacts:

Mol	Chain	Res	Type	Clashes	Symm-Clashes
3	C	269	A5P	3	0
2	B	268	PEP	4	0
3	K	269	A5P	1	0
3	J	269	A5P	2	0
2	A	268	PEP	2	0
2	L	268	PEP	2	0
3	B	269	A5P	6	0
3	I	269	A5P	3	0
3	F	269	A5P	4	0
2	F	268	PEP	2	0
2	K	268	PEP	2	0
3	G	269	A5P	3	0
3	H	269	A5P	3	0
4	D	268	1NT	4	0
2	C	268	PEP	2	0
2	I	268	PEP	5	0
2	J	268	PEP	3	0
3	A	269	A5P	2	0
2	E	268	PEP	1	0
3	L	269	A5P	1	0
2	G	268	PEP	1	0
2	H	268	PEP	5	0

The following is a two-dimensional graphical depiction of Mogul quality analysis of bond lengths,

bond angles, torsion angles, and ring geometry for all instances of the Ligand of Interest. In addition, ligands with molecular weight > 250 and outliers as shown on the validation Tables will also be included. For torsion angles, if less than 5% of the Mogul distribution of torsion angles is within 10 degrees of the torsion angle in question, then that torsion angle is considered an outlier. Any bond that is central to one or more torsion angles identified as an outlier by Mogul will be highlighted in the graph. For rings, the root-mean-square deviation (RMSD) between the ring in question and similar rings identified by Mogul is calculated over all ring torsion angles. If the average RMSD is greater than 60 degrees and the minimal RMSD between the ring in question and any Mogul-identified rings is also greater than 60 degrees, then that ring is considered an outlier. The outliers are highlighted in purple. The color gray indicates Mogul did not find sufficient equivalents in the CSD to analyse the geometry.

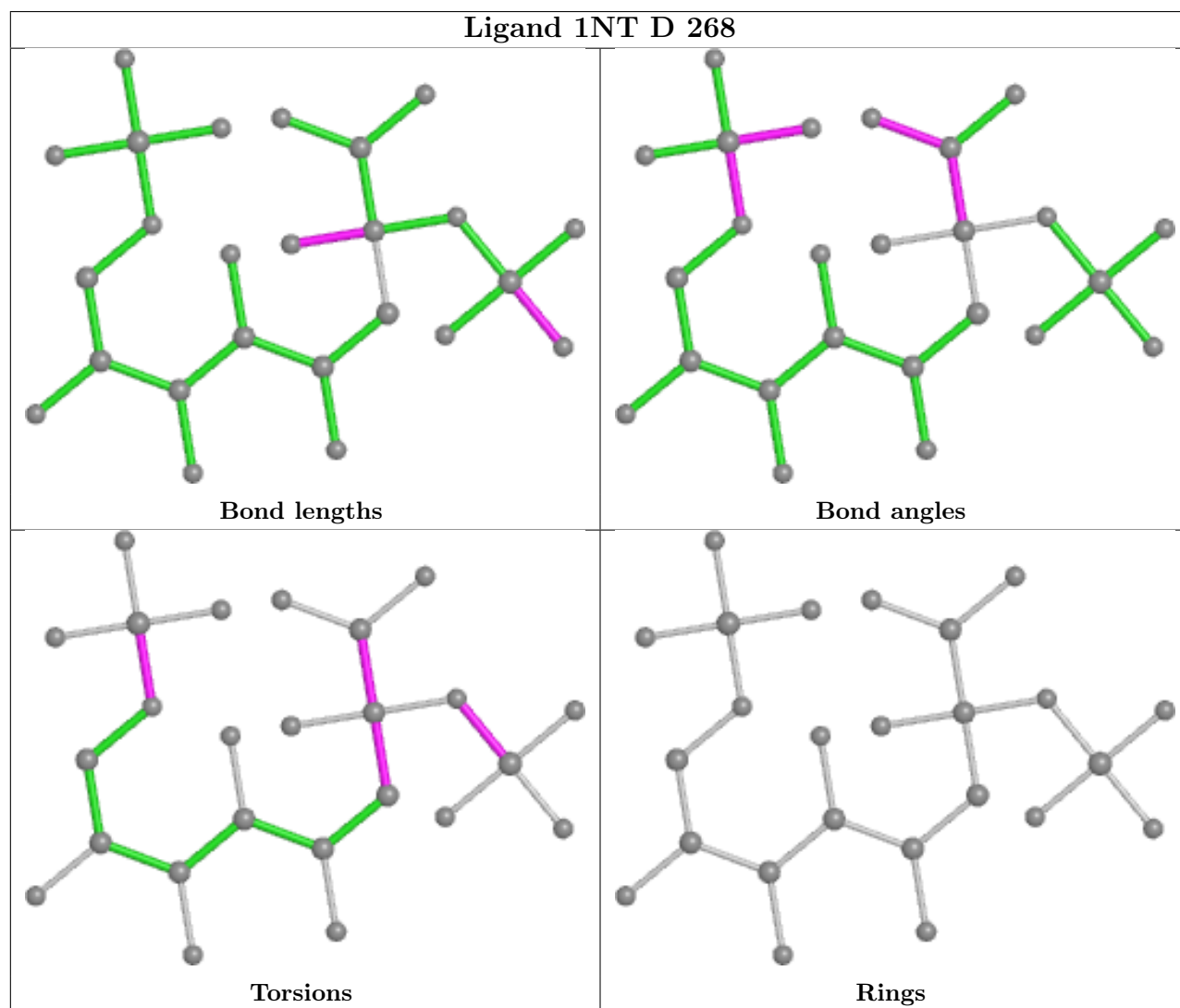

5.7 Other polymers [\(i\)](#)

There are no such residues in this entry.

5.8 Polymer linkage issues

There are no chain breaks in this entry.

6 Fit of model and data [i](#)

6.1 Protein, DNA and RNA chains [i](#)

In the following table, the column labelled ‘#RSRZ > 2’ contains the number (and percentage) of RSRZ outliers, followed by percent RSRZ outliers for the chain as percentile scores relative to all X-ray entries and entries of similar resolution. The OWAB column contains the minimum, median, 95th percentile and maximum values of the occupancy-weighted average B-factor per residue. The column labelled ‘Q < 0.9’ lists the number of (and percentage) of residues with an average occupancy less than 0.9.

Mol	Chain	Analysed	<RSRZ>	#RSRZ>2	OWAB(Å ²)	Q<0.9
1	A	262/267 (98%)	0.23	11 (4%) 36 42	16, 27, 50, 74	0
1	B	262/267 (98%)	0.34	15 (5%) 23 29	16, 28, 49, 71	0
1	C	262/267 (98%)	0.78	29 (11%) 5 7	23, 47, 65, 72	0
1	D	262/267 (98%)	1.20	51 (19%) 1 1	24, 52, 72, 79	0
1	E	262/267 (98%)	1.29	63 (24%) 0 0	26, 58, 82, 90	0
1	F	262/267 (98%)	1.64	75 (28%) 0 0	30, 60, 78, 89	0
1	G	262/267 (98%)	0.40	14 (5%) 26 32	19, 32, 61, 86	0
1	H	262/267 (98%)	0.38	14 (5%) 26 32	19, 31, 56, 75	0
1	I	262/267 (98%)	0.34	14 (5%) 26 32	19, 29, 48, 69	0
1	J	262/267 (98%)	0.41	18 (6%) 16 21	19, 30, 59, 79	0
1	K	262/267 (98%)	1.63	91 (34%) 0 0	30, 62, 82, 87	0
1	L	262/267 (98%)	1.14	47 (17%) 1 1	26, 50, 68, 86	0
All	All	3144/3204 (98%)	0.81	442 (14%) 2 3	16, 40, 74, 90	0

The worst 5 of 442 RSRZ outliers are listed below:

Mol	Chain	Res	Type	RSRZ
1	G	264	ILE	10.9
1	L	193	LEU	9.2
1	E	195	ASP	8.0
1	H	264	ILE	7.8
1	F	193	LEU	7.8

6.2 Non-standard residues in protein, DNA, RNA chains [i](#)

There are no non-standard protein/DNA/RNA residues in this entry.

6.3 Carbohydrates [i](#)

There are no monosaccharides in this entry.

6.4 Ligands [i](#)

In the following table, the Atoms column lists the number of modelled atoms in the group and the number defined in the chemical component dictionary. The B-factors column lists the minimum, median, 95th percentile and maximum values of B factors of atoms in the group. The column labelled 'Q< 0.9' lists the number of atoms with occupancy less than 0.9.

Mol	Type	Chain	Res	Atoms	RSCC	RSR	B-factors(Å ²)	Q<0.9
3	A5P	L	269	14/14	0.66	0.32	77,78,79,79	0
3	A5P	K	269	14/14	0.78	0.23	72,74,75,75	0
3	A5P	E	269	14/14	0.83	0.21	70,72,73,74	0
3	A5P	F	269	14/14	0.84	0.23	77,81,84,85	0
4	1NT	D	268	25/25	0.84	0.23	59,64,67,68	0
3	A5P	C	269	14/14	0.88	0.17	53,61,64,65	0
3	A5P	G	269	14/14	0.89	0.20	38,45,48,51	0
2	PEP	F	268	10/10	0.90	0.21	62,66,71,72	0
2	PEP	L	268	10/10	0.90	0.24	61,65,66,66	0
3	A5P	J	269	14/14	0.90	0.19	35,42,47,48	0
2	PEP	C	268	10/10	0.92	0.23	52,58,65,65	0
3	A5P	H	269	14/14	0.93	0.18	41,49,56,58	0
3	A5P	I	269	14/14	0.93	0.16	35,40,47,47	0
2	PEP	G	268	10/10	0.93	0.18	35,39,43,43	0
2	PEP	H	268	10/10	0.93	0.20	41,46,48,49	0
2	PEP	E	268	10/10	0.93	0.27	63,66,67,67	0
3	A5P	B	269	14/14	0.93	0.17	35,40,45,47	0
2	PEP	J	268	10/10	0.94	0.20	36,39,40,42	0
2	PEP	K	268	10/10	0.94	0.22	67,70,74,74	0
3	A5P	A	269	14/14	0.95	0.18	36,46,51,54	0
2	PEP	I	268	10/10	0.95	0.18	32,41,45,45	0
2	PEP	B	268	10/10	0.95	0.18	31,37,39,40	0
2	PEP	A	268	10/10	0.96	0.14	30,34,35,37	0

The following is a graphical depiction of the model fit to experimental electron density of all instances of the Ligand of Interest. In addition, ligands with molecular weight > 250 and outliers as shown on the geometry validation Tables will also be included. Each fit is shown from different orientation to approximate a three-dimensional view.

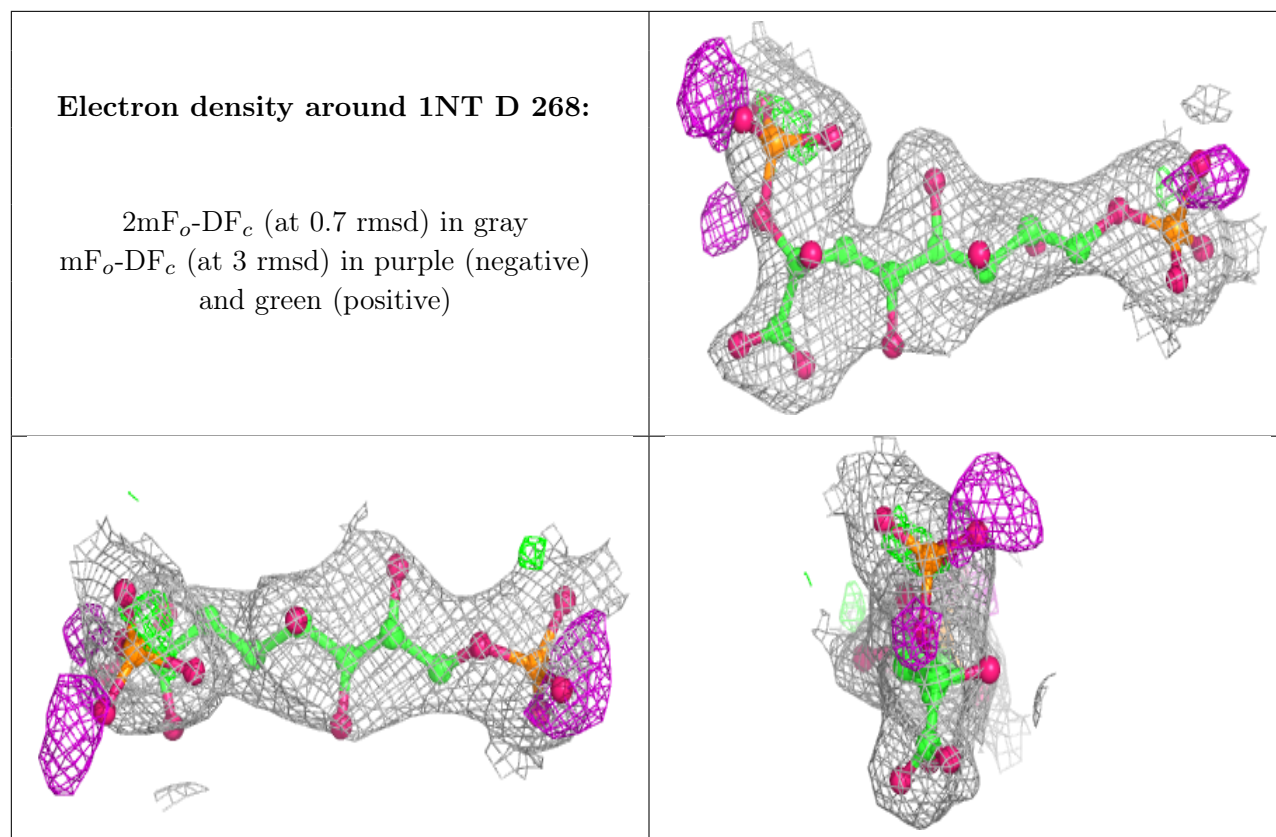

6.5 Other polymers [i](#)

There are no such residues in this entry.