



Full wwPDB EM Validation Report ⓘ

May 21, 2024 – 01:24 PM EDT

PDB ID : 8UQL
EMDB ID : EMD-42473
Title : Escherichia coli transcription-translation coupled complex class B (TTC-B) containing RfaH in loaded state, mRNA with a 24 nt long spacer, and fMet-tRNAs in E-site and P-site of the ribosome
Authors : Molodtsov, V.; Wang, C.; Ebright, R.H.
Deposited on : 2023-10-24
Resolution : 3.20 Å(reported)

This is a Full wwPDB EM Validation Report for a publicly released PDB entry.

We welcome your comments at validation@mail.wwpdb.org

A user guide is available at

<https://www.wwpdb.org/validation/2017/EMValidationReportHelp>

with specific help available everywhere you see the ⓘ symbol.

The types of validation reports are described at

<http://www.wwpdb.org/validation/2017/FAQs#types>.

The following versions of software and data (see [references ⓘ](#)) were used in the production of this report:

EMDB validation analysis : 0.0.1.dev92
MolProbity : 4.02b-467
Percentile statistics : 20191225.v01 (using entries in the PDB archive December 25th 2019)
MapQ : 1.9.13
Ideal geometry (proteins) : Engh & Huber (2001)
Ideal geometry (DNA, RNA) : Parkinson et al. (1996)
Validation Pipeline (wwPDB-VP) : 2.36.2

1 Overall quality at a glance i

The following experimental techniques were used to determine the structure:
ELECTRON MICROSCOPY

The reported resolution of this entry is 3.20 Å.

Percentile scores (ranging between 0-100) for global validation metrics of the entry are shown in the following graphic. The table shows the number of entries on which the scores are based.

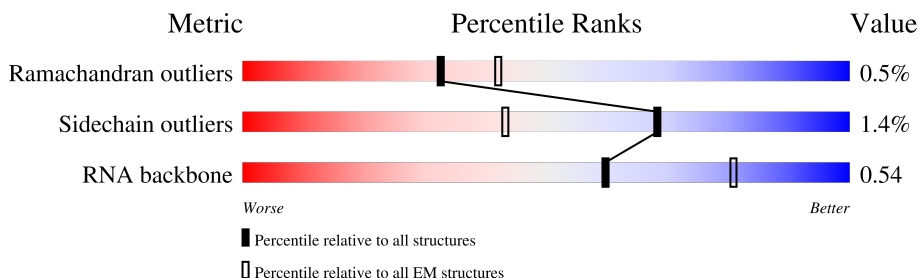









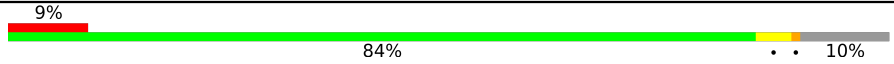

Metric	Whole archive (#Entries)	EM structures (#Entries)
Ramachandran outliers	154571	4023
Sidechain outliers	154315	3826
RNA backbone	4643	859

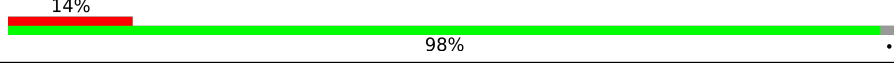
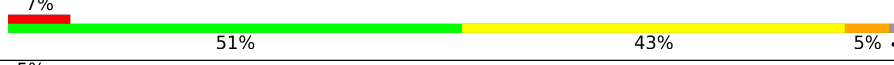
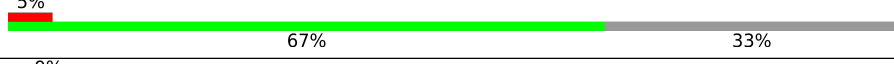
The table below summarises the geometric issues observed across the polymeric chains and their fit to the map. The red, orange, yellow and green segments of the bar indicate the fraction of residues that contain outliers for ≥ 3 , 2, 1 and 0 types of geometric quality criteria respectively. A grey segment represents the fraction of residues that are not modelled. The numeric value for each fraction is indicated below the corresponding segment, with a dot representing fractions $\leq 5\%$. The upper red bar (where present) indicates the fraction of residues that have poor fit to the EM map (all-atom inclusion $< 40\%$). The numeric value is given above the bar.

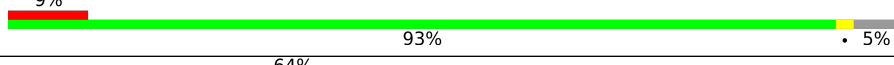
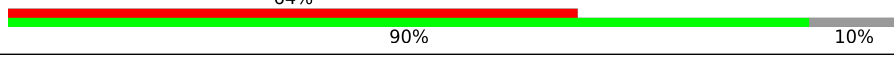
Mol	Chain	Length	Quality of chain
1	0	103	
2	1	110	
3	2	100	
4	3	104	
5	4	94	
6	5	36	
7	6	36	
8	7	41	

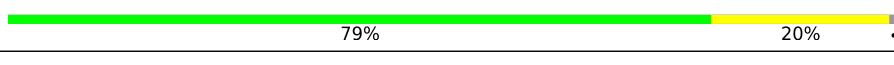
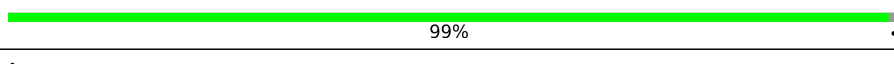
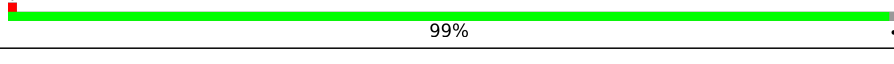
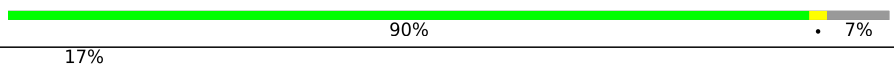
Continued on next page...

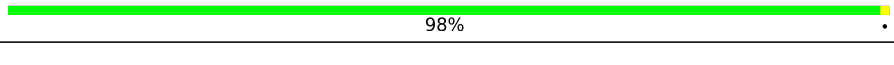
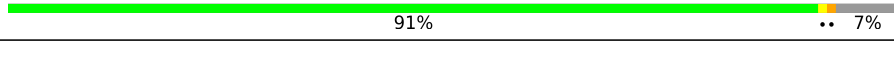
Continued from previous page...

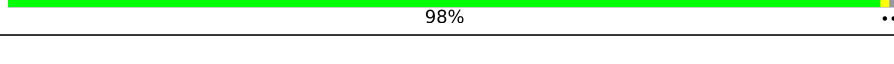
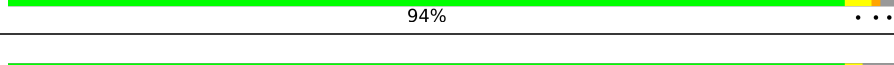
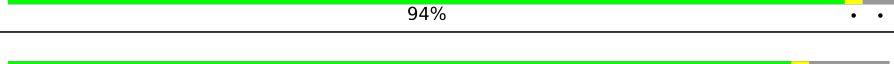
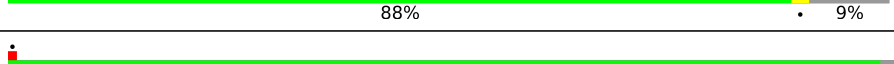
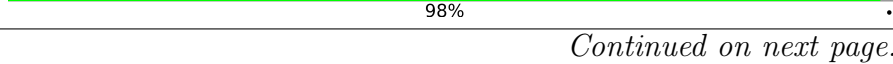
Mol	Chain	Length	Quality of chain
9	9	165	
10	A	76	
10	B	76	
11	AA	1342	
12	AB	162	
13	AC	329	
13	AD	329	
14	AE	1407	
15	AF	91	
16	C	75	
17	D	1542	
18	E	87	
19	F	71	
20	G	241	
21	H	557	
22	I	233	
23	J	206	
24	K	167	
25	L	135	
26	M	179	
27	N	130	
28	O	130	
29	P	103	
30	Q	129	
31	R	124	

Continued on next page...

Continued from previous page...

Mol	Chain	Length	Quality of chain
32	S	101	98%
33	T	89	98%
34	U	82	98%
35	V	84	94%
36	W	92	87%
37	X	118	95%
38	Y	142	98%
39	Z	121	25%
40	a	2904	80%
41	b	85	89%
42	c	78	96%
43	d	120	88%
44	e	63	95%
45	f	59	97%
46	g	70	93%
47	h	273	98%
48	i	57	96%
49	j	209	99%
50	k	55	95%
51	l	201	99%
52	m	46	100%
53	n	179	97%
54	o	65	94%
55	p	177	98%
56	q	38	100%

Continued on next page...

Continued from previous page...

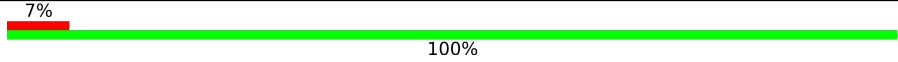
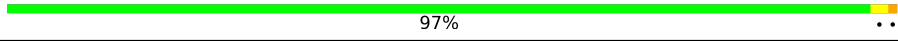
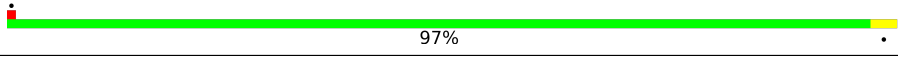
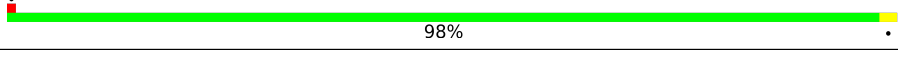
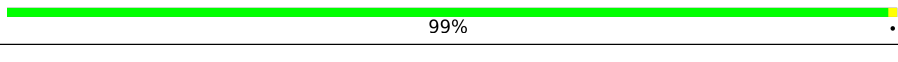
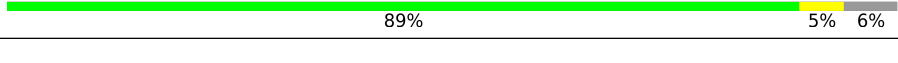
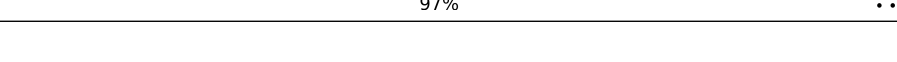
Mol	Chain	Length	Quality of chain
57	r	149	 7% 100%
58	s	142	 97% ..
59	t	123	 97% .
60	u	144	 98% .
61	v	136	 99% .
62	w	127	 89% 5% 6%
63	x	117	 99% .
64	y	115	 97% ..
65	z	118	 97% ..

2 Entry composition [i](#)

There are 67 unique types of molecules in this entry. The entry contains 275952 atoms, of which 98639 are hydrogens and 0 are deuteriums.

In the tables below, the AltConf column contains the number of residues with at least one atom in alternate conformation and the Trace column contains the number of residues modelled with at most 2 atoms.

- Molecule 1 is a protein called Ribosomal protein L21.

Mol	Chain	Residues	Atoms					AltConf	Trace	
			Total	C	H	N	O			S
1	0	103	1655	516	839	153	145	2	0	0

- Molecule 2 is a protein called 50S ribosomal protein L22.

Mol	Chain	Residues	Atoms					AltConf	Trace	
			Total	C	H	N	O			S
2	1	110	1779	532	922	166	156	3	0	0

- Molecule 3 is a protein called 50S ribosomal protein L23.

Mol	Chain	Residues	Atoms					AltConf	Trace	
			Total	C	H	N	O			S
3	2	94	1557	470	811	140	134	2	0	0

- Molecule 4 is a protein called 50S ribosomal protein L24.

Mol	Chain	Residues	Atoms					AltConf	Trace
			Total	C	H	N	O		
4	3	103	1632	498	844	148	142	0	0

- Molecule 5 is a protein called 50S ribosomal protein L25.

Mol	Chain	Residues	Atoms					AltConf	Trace	
			Total	C	H	N	O			S
5	4	94	1533	479	780	137	134	3	0	0

- Molecule 6 is a DNA chain called NT DNA.

Mol	Chain	Residues	Atoms					AltConf	Trace
			Total	C	N	O	P		
6	5	31	636	303	117	185	31	0	0

- Molecule 7 is a DNA chain called T DNA.

Mol	Chain	Residues	Atoms					AltConf	Trace
			Total	C	N	O	P		
7	6	36	706	337	119	215	35	0	0

- Molecule 8 is a RNA chain called mRNA with 24 nt long spacer.

Mol	Chain	Residues	Atoms					AltConf	Trace
			Total	C	N	O	P		
8	7	37	772	345	110	280	37	0	0

- Molecule 9 is a protein called 50S ribosomal protein L10.

Mol	Chain	Residues	Atoms					AltConf	Trace
			Total	C	N	O	S		
9	9	148	1117	705	196	209	7	0	0

- Molecule 10 is a RNA chain called E-site and P-site fMet-tRNA.

Mol	Chain	Residues	Atoms					AltConf	Trace	
			Total	C	H	N	O			P
10	A	76	2446	723	826	295	527	75	0	0
10	B	76	2434	723	814	295	527	75	0	0

- Molecule 11 is a protein called DNA-directed RNA polymerase subunit beta.

Mol	Chain	Residues	Atoms					AltConf	Trace
			Total	C	N	O	S		
11	AA	1316	10381	6514	1810	2014	43	0	0

- Molecule 12 is a protein called Transcription antitermination protein RfaH.

Mol	Chain	Residues	Atoms					AltConf	Trace
			Total	C	N	O	S		
12	AB	161	1286	828	222	232	4	0	0

- Molecule 13 is a protein called DNA-directed RNA polymerase subunit alpha.

Mol	Chain	Residues	Atoms					AltConf	Trace
			Total	C	N	O	S		
13	AC	221	1698	1060	299	333	6	0	0

Continued on next page...

Continued from previous page...

Mol	Chain	Residues	Atoms					AltConf	Trace
			Total	C	N	O	S		
13	AD	218	1677	1048	297	326	6	0	0

- Molecule 14 is a protein called DNA-directed RNA polymerase subunit beta'.

Mol	Chain	Residues	Atoms					AltConf	Trace
			Total	C	N	O	S		
14	AE	1337	10404	6535	1856	1963	50	0	0

- Molecule 15 is a protein called DNA-directed RNA polymerase subunit omega.

Mol	Chain	Residues	Atoms					AltConf	Trace
			Total	C	N	O	S		
15	AF	82	650	396	122	131	1	0	0

- Molecule 16 is a protein called 30S ribosomal protein S18.

Mol	Chain	Residues	Atoms						AltConf	Trace
			Total	C	H	N	O	S		
16	C	66	1103	344	559	102	97	1	0	0

- Molecule 17 is a RNA chain called 16S rRNA.

Mol	Chain	Residues	Atoms						AltConf	Trace
			Total	C	H	N	O	P		
17	D	1524	49126	14585	16423	6003	10591	1524	0	0

- Molecule 18 is a protein called 30S ribosomal protein S20.

Mol	Chain	Residues	Atoms					AltConf	Trace	
			Total	C	H	N	O			S
18	E	86	1388	414	719	138	114	3	0	0

- Molecule 19 is a protein called 30S ribosomal protein S21.

Mol	Chain	Residues	Atoms					AltConf	Trace	
			Total	C	H	N	O			S
19	F	70	1218	366	629	125	97	1	0	0

- Molecule 20 is a protein called 30S ribosomal protein S2.

Mol	Chain	Residues	Atoms						AltConf	Trace
			Total	C	H	N	O	S		
20	G	225	3545	1113	1785	316	323	8	0	0

- Molecule 21 is a protein called 30S ribosomal protein S1.

Mol	Chain	Residues	Atoms						AltConf	Trace
			Total	C	H	N	O	S		
21	H	259	3184	1073	1454	305	349	3	0	0

- Molecule 22 is a protein called 30S ribosomal protein S3.

Mol	Chain	Residues	Atoms						AltConf	Trace
			Total	C	H	N	O	S		
22	I	208	3346	1036	1710	307	290	3	0	0

- Molecule 23 is a protein called 30S ribosomal protein S4.

Mol	Chain	Residues	Atoms						AltConf	Trace
			Total	C	H	N	O	S		
23	J	205	3350	1026	1707	315	298	4	0	0

- Molecule 24 is a protein called 30S ribosomal protein S5.

Mol	Chain	Residues	Atoms						AltConf	Trace
			Total	C	H	N	O	S		
24	K	156	2348	717	1196	217	212	6	0	0

- Molecule 25 is a protein called 30S ribosomal protein S6.

Mol	Chain	Residues	Atoms						AltConf	Trace
			Total	C	H	N	O	S		
25	L	104	1694	536	846	153	152	7	0	0

- Molecule 26 is a protein called 30S ribosomal protein S7.

Mol	Chain	Residues	Atoms						AltConf	Trace
			Total	C	H	N	O	S		
26	M	151	2416	735	1235	227	215	4	0	0

- Molecule 27 is a protein called 30S ribosomal protein S8.

Mol	Chain	Residues	Atoms						AltConf	Trace
27	N	129	Total	C	H	N	O	S	0	0
			2010	616	1031	173	184	6		

- Molecule 28 is a protein called 30S ribosomal protein S9.

Mol	Chain	Residues	Atoms						AltConf	Trace
28	O	127	Total	C	H	N	O	S	0	0
			2092	634	1070	206	179	3		

- Molecule 29 is a protein called 30S ribosomal protein S10.

Mol	Chain	Residues	Atoms						AltConf	Trace
29	P	99	Total	C	H	N	O	S	0	0
			1621	495	831	151	143	1		

- Molecule 30 is a protein called 30S ribosomal protein S11.

Mol	Chain	Residues	Atoms						AltConf	Trace
30	Q	117	Total	C	H	N	O	S	0	0
			1764	540	887	174	160	3		

- Molecule 31 is a protein called 30S ribosomal protein S12.

Mol	Chain	Residues	Atoms						AltConf	Trace
31	R	121	Total	C	H	N	O	S	0	0
			1940	580	1001	194	161	4		

- Molecule 32 is a protein called 30S ribosomal protein S14.

Mol	Chain	Residues	Atoms						AltConf	Trace
32	S	100	Total	C	H	N	O	S	0	0
			1649	499	844	164	139	3		

- Molecule 33 is a protein called 30S ribosomal protein S15.

Mol	Chain	Residues	Atoms						AltConf	Trace
33	T	88	Total	C	H	N	O	S	0	0
			1448	439	734	144	130	1		

- Molecule 34 is a protein called 30S ribosomal protein S16.

Mol	Chain	Residues	Atoms					AltConf	Trace	
34	U	82	Total	C	H	N	O	S	0	0
			1315	406	666	128	114	1		

- Molecule 35 is a protein called 30S ribosomal protein S17.

Mol	Chain	Residues	Atoms					AltConf	Trace	
35	V	80	Total	C	H	N	O	S	0	0
			1339	411	691	121	113	3		

- Molecule 36 is a protein called 30S ribosomal protein S19.

Mol	Chain	Residues	Atoms					AltConf	Trace	
36	W	83	Total	C	H	N	O	S	0	0
			1351	424	688	126	111	2		

- Molecule 37 is a protein called 30S ribosomal protein S13.

Mol	Chain	Residues	Atoms					AltConf	Trace	
37	X	116	Total	C	H	N	O	S	0	0
			1864	558	964	181	158	3		

- Molecule 38 is a protein called 50S ribosomal protein L11.

Mol	Chain	Residues	Atoms					AltConf	Trace
38	Y	141	Total	C	N	O	S	0	0
			1032	651	179	196	6		

- Molecule 39 is a protein called 50S ribosomal protein L7/L12.

Mol	Chain	Residues	Atoms					AltConf	Trace
39	Z	30	Total	C	N	O	S	0	0
			227	144	33	47	3		

- Molecule 40 is a RNA chain called 23S rRNA.

Mol	Chain	Residues	Atoms					AltConf	Trace	
40	a	2880	Total	C	H	N	O	P	0	0
			92918	27587	31077	11398	19976	2880		

There is a discrepancy between the modelled and reference sequences:

Chain	Residue	Modelled	Actual	Comment	Reference
a	887	A	U	conflict	GB 937521852

- Molecule 41 is a protein called 50S ribosomal protein L27.

Mol	Chain	Residues	Atoms					AltConf	Trace	
			Total	C	H	N	O			S
41	b	76	1181	360	599	117	104	1	0	0

- Molecule 42 is a protein called 50S ribosomal protein L28.

Mol	Chain	Residues	Atoms					AltConf	Trace	
			Total	C	H	N	O			S
42	c	77	1277	388	652	129	106	2	0	0

- Molecule 43 is a RNA chain called 5S rRNA.

Mol	Chain	Residues	Atoms					AltConf	Trace	
			Total	C	H	N	O			P
43	d	120	3870	1144	1301	468	837	120	0	0

- Molecule 44 is a protein called 50S ribosomal protein L29.

Mol	Chain	Residues	Atoms					AltConf	Trace	
			Total	C	H	N	O			S
44	e	62	1032	308	531	98	94	1	0	0

- Molecule 45 is a protein called 50S ribosomal protein L30.

Mol	Chain	Residues	Atoms					AltConf	Trace	
			Total	C	H	N	O			S
45	f	58	936	281	488	87	78	2	0	0

- Molecule 46 is a protein called 50S ribosomal protein L31.

Mol	Chain	Residues	Atoms					AltConf	Trace	
			Total	C	H	N	O			S
46	g	66	1042	323	520	99	94	6	0	0

- Molecule 47 is a protein called 50S ribosomal protein L2.

Mol	Chain	Residues	Atoms						AltConf	Trace
			Total	C	H	N	O	S		
47	h	271	4236	1288	2154	423	364	7	0	0

- Molecule 48 is a protein called 50S ribosomal protein L32.

Mol	Chain	Residues	Atoms						AltConf	Trace
			Total	C	H	N	O	S		
48	i	56	903	269	459	94	80	1	0	0

- Molecule 49 is a protein called 50S ribosomal protein L3.

Mol	Chain	Residues	Atoms						AltConf	Trace
			Total	C	H	N	O	S		
49	j	209	3182	979	1617	288	294	4	0	0

- Molecule 50 is a protein called 50S ribosomal protein L33.

Mol	Chain	Residues	Atoms					AltConf	Trace
			Total	C	H	N	O		
50	k	52	890	275	464	78	73	0	0

- Molecule 51 is a protein called 50S ribosomal protein L4.

Mol	Chain	Residues	Atoms						AltConf	Trace
			Total	C	H	N	O	S		
51	l	201	3171	974	1619	283	290	5	0	0

- Molecule 52 is a protein called 50S ribosomal protein L34.

Mol	Chain	Residues	Atoms						AltConf	Trace
			Total	C	H	N	O	S		
52	m	46	795	228	418	90	57	2	0	0

- Molecule 53 is a protein called 50S ribosomal protein L5.

Mol	Chain	Residues	Atoms						AltConf	Trace
			Total	C	H	N	O	S		
53	n	177	2853	899	1443	249	256	6	0	0

- Molecule 54 is a protein called 50S ribosomal protein L35.

Mol	Chain	Residues	Atoms					AltConf	Trace	
54	o	64	Total	C	H	N	O	S	0	0
			1076	323	572	105	74	2		

- Molecule 55 is a protein called 50S ribosomal protein L6.

Mol	Chain	Residues	Atoms					AltConf	Trace	
55	p	175	Total	C	H	N	O	S	0	0
			2671	826	1358	241	244	2		

- Molecule 56 is a protein called 50S ribosomal protein L36.

Mol	Chain	Residues	Atoms					AltConf	Trace	
56	q	38	Total	C	H	N	O	S	0	0
			645	185	343	65	48	4		

- Molecule 57 is a protein called 50S ribosomal protein L9.

Mol	Chain	Residues	Atoms					AltConf	Trace	
57	r	149	Total	C	H	N	O	S	0	0
			2259	699	1148	197	214	1		

- Molecule 58 is a protein called 50S ribosomal protein L13.

Mol	Chain	Residues	Atoms					AltConf	Trace	
58	s	142	Total	C	H	N	O	S	0	0
			2291	714	1162	212	199	4		

- Molecule 59 is a protein called 50S ribosomal protein L14.

Mol	Chain	Residues	Atoms					AltConf	Trace	
59	t	123	Total	C	H	N	O	S	0	0
			1969	593	1023	181	166	6		

- Molecule 60 is a protein called 50S ribosomal protein L15.

Mol	Chain	Residues	Atoms					AltConf	Trace	
60	u	144	Total	C	H	N	O	S	0	0
			2182	654	1129	207	190	2		

- Molecule 61 is a protein called 50S ribosomal protein L16.

Mol	Chain	Residues	Atoms					AltConf	Trace	
			Total	C	H	N	O			S
61	v	136	2231	686	1157	205	177	6	0	0

- Molecule 62 is a protein called 50S ribosomal protein L17.

Mol	Chain	Residues	Atoms					AltConf	Trace	
			Total	C	H	N	O			S
62	w	119	1945	588	994	195	163	5	0	0

- Molecule 63 is a protein called 50S ribosomal protein L18.

Mol	Chain	Residues	Atoms					AltConf	Trace	
			Total	C	H	N	O			S
63	x	116	1815	552	923	178	162		0	0

- Molecule 64 is a protein called 50S ribosomal protein L19.

Mol	Chain	Residues	Atoms					AltConf	Trace	
			Total	C	H	N	O			S
64	y	114	1879	574	962	179	163	1	0	0

- Molecule 65 is a protein called 50S ribosomal protein L20.

Mol	Chain	Residues	Atoms					AltConf	Trace	
			Total	C	H	N	O			S
65	z	117	1967	604	1020	192	151		0	0

- Molecule 66 is MAGNESIUM ION (three-letter code: MG) (formula: Mg).

Mol	Chain	Residues	Atoms		AltConf
			Total	Mg	
66	AE	1	1	1	0

- Molecule 67 is ZINC ION (three-letter code: ZN) (formula: Zn).

Mol	Chain	Residues	Atoms		AltConf
			Total	Zn	
67	AE	2	2	2	0

3 Residue-property plots [i](#)

These plots are drawn for all protein, RNA, DNA and oligosaccharide chains in the entry. The first graphic for a chain summarises the proportions of the various outlier classes displayed in the second graphic. The second graphic shows the sequence view annotated by issues in geometry and atom inclusion in map density. Residues are color-coded according to the number of geometric quality criteria for which they contain at least one outlier: green = 0, yellow = 1, orange = 2 and red = 3 or more. A red diamond above a residue indicates a poor fit to the EM map for this residue (all-atom inclusion < 40%). Stretches of 2 or more consecutive residues without any outlier are shown as a green connector. Residues present in the sample, but not in the model, are shown in grey.

- Molecule 1: Ribosomal protein L21

Chain 0:  100%

There are no outlier residues recorded for this chain.

- Molecule 2: 50S ribosomal protein L22

Chain 1:  100%

There are no outlier residues recorded for this chain.

- Molecule 3: 50S ribosomal protein L23

Chain 2:  91% 6%

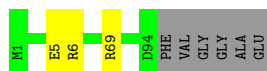

- Molecule 4: 50S ribosomal protein L24

Chain 3:  99%



- Molecule 5: 50S ribosomal protein L25

Chain 4:  98%



- Molecule 6: NT DNA

Chain 5:  14% 53% 33% 14%

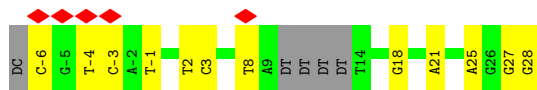

- Molecule 7: T DNA

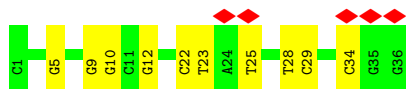

- Molecule 8: mRNA with 24 nt long spacer

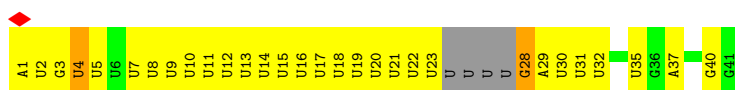
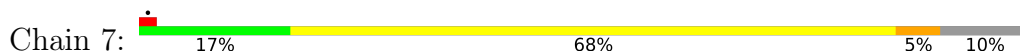

- Molecule 9: 50S ribosomal protein L10

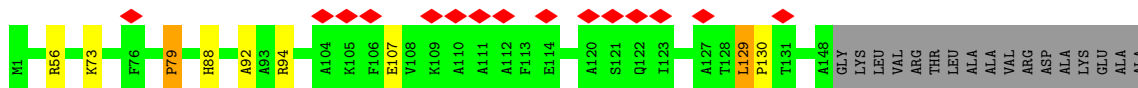
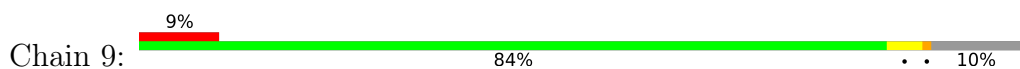

- Molecule 10: E-site and P-site fMet-tRNA

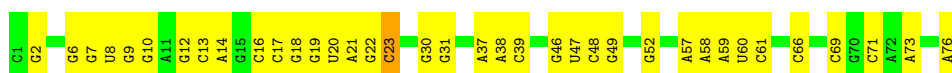

- Molecule 10: E-site and P-site fMet-tRNA

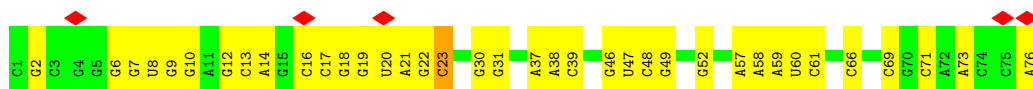

- Molecule 11: DNA-directed RNA polymerase subunit beta

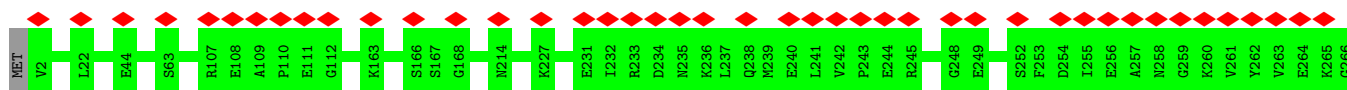

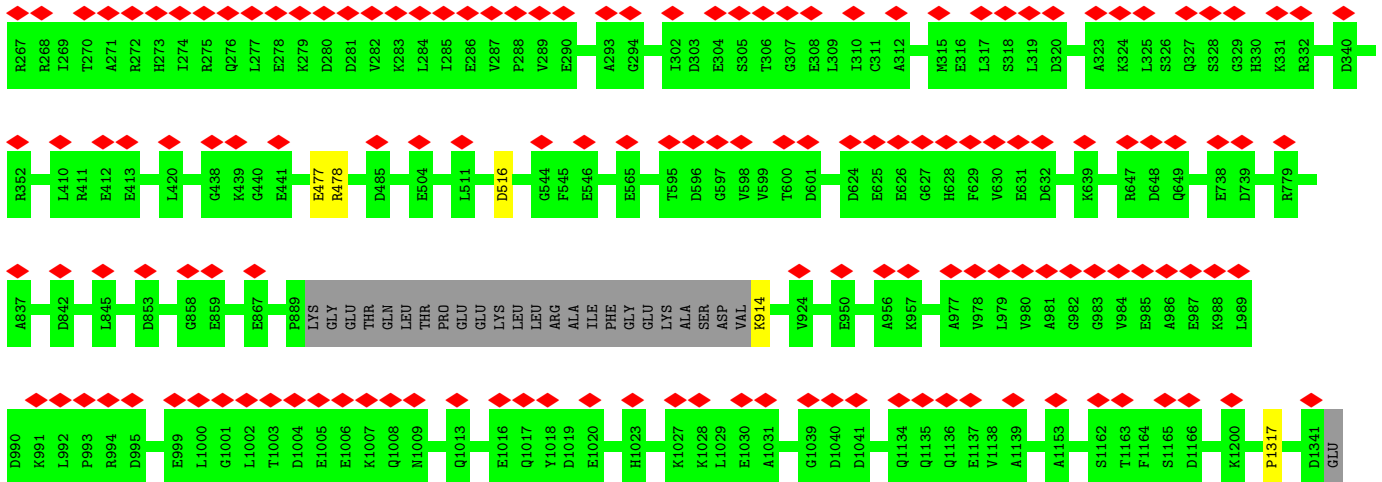

• Molecule 12: Transcription antitermination protein RfaH

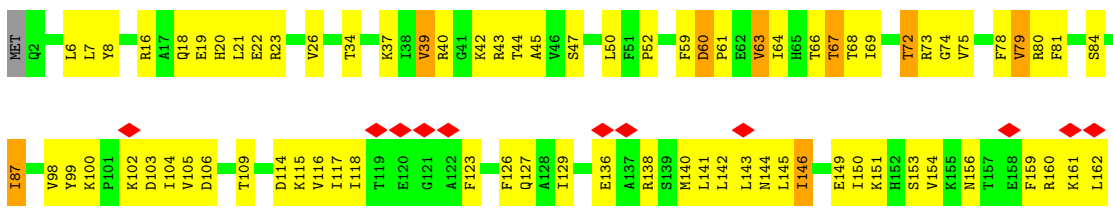

• Molecule 13: DNA-directed RNA polymerase subunit alpha

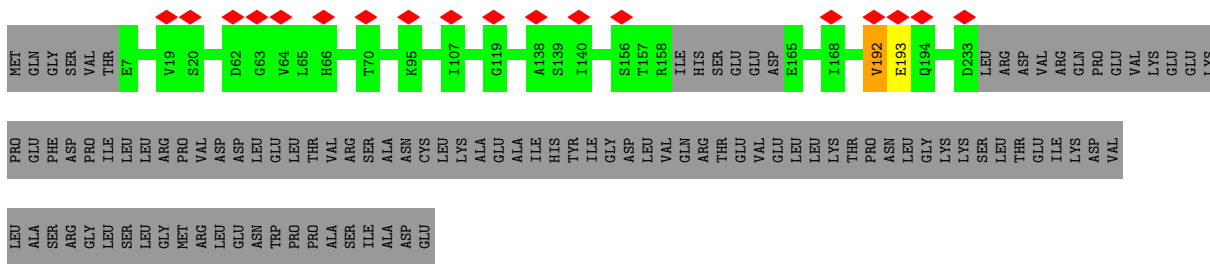

• Molecule 13: DNA-directed RNA polymerase subunit alpha

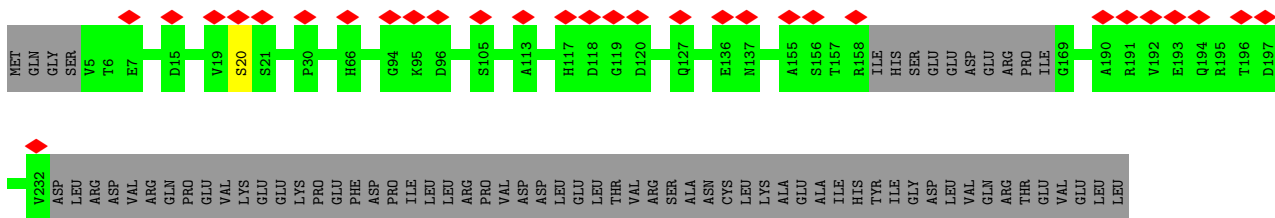

LYS THR PRO ASN LEU LEU GLY LYS LYS SER LEU THR GLU ILE LYS ASP VAL LEU ALA ALA SER ARG GLY LEU SER LEU MET ARG LEU ASN TRP PRO PRO ALA ILE SER ILE ALA ASP GLU

• Molecule 14: DNA-directed RNA polymerase subunit beta'

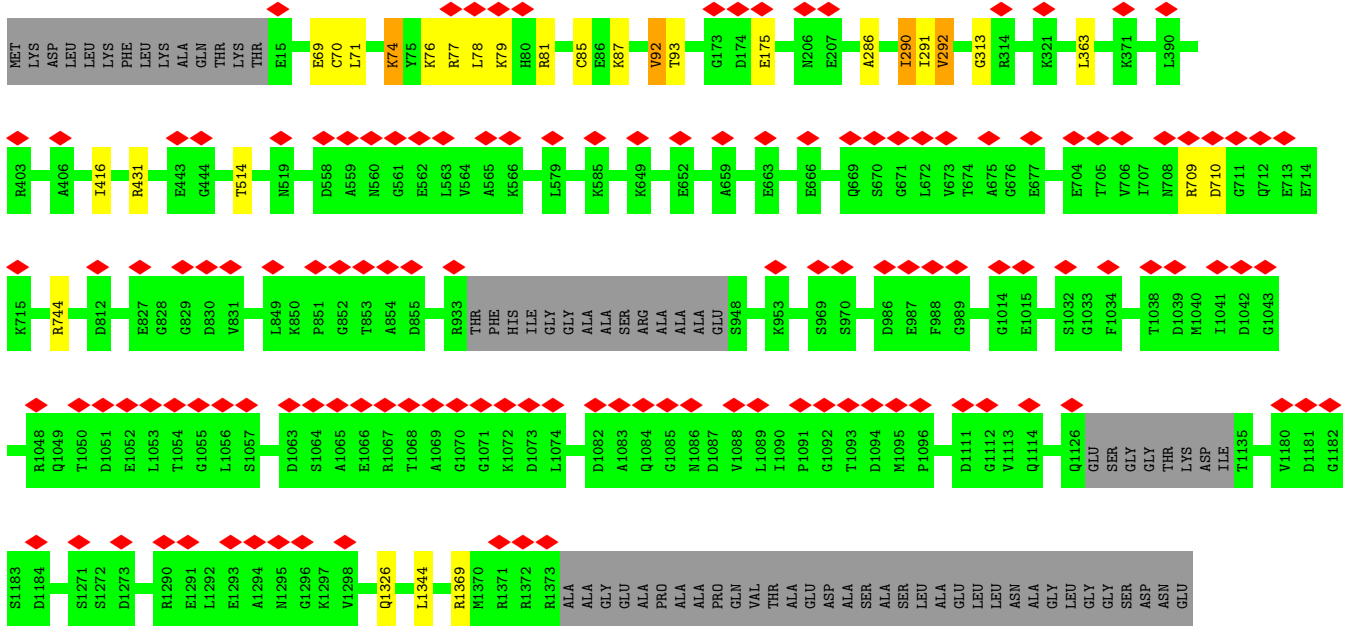

• Molecule 15: DNA-directed RNA polymerase subunit omega

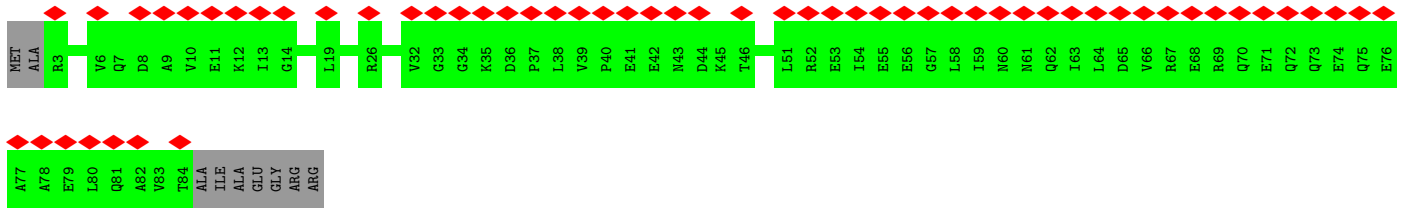
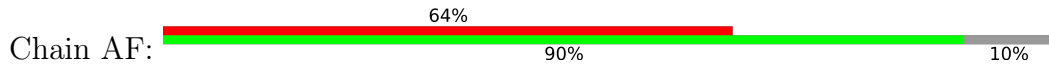

• Molecule 16: 30S ribosomal protein S18

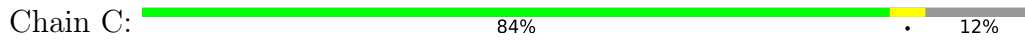

• Molecule 17: 16S rRNA

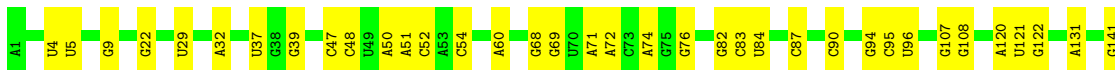
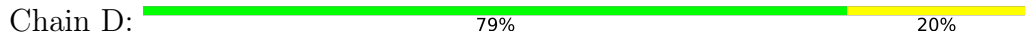

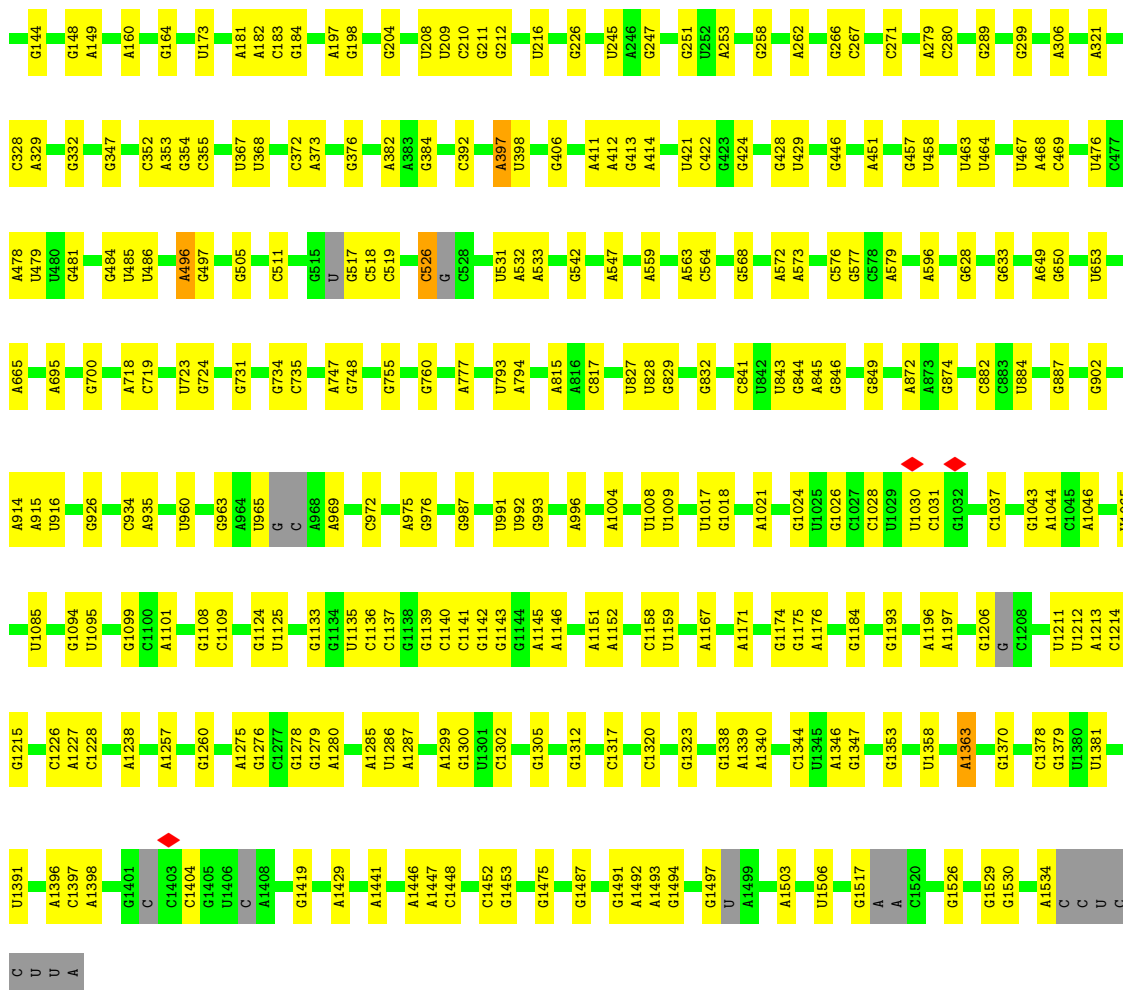

• Molecule 18: 30S ribosomal protein S20



• Molecule 19: 30S ribosomal protein S21

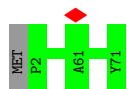

• Molecule 20: 30S ribosomal protein S2



Chain L:  74% 23%

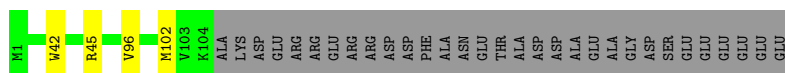

- Molecule 26: 30S ribosomal protein S7

Chain M:  83% 16%

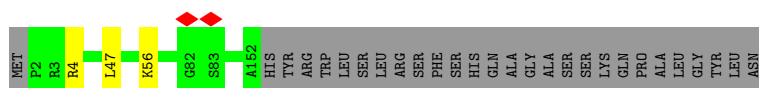

- Molecule 27: 30S ribosomal protein S8

Chain N:  98%



- Molecule 28: 30S ribosomal protein S9

Chain O:  94%



- Molecule 29: 30S ribosomal protein S10

Chain P:  94%

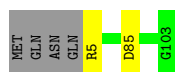

- Molecule 30: 30S ribosomal protein S11

Chain Q:  88% 9%

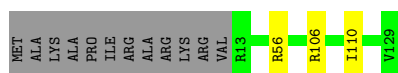

- Molecule 31: 30S ribosomal protein S12

Chain R:  98%

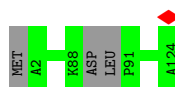

- Molecule 32: 30S ribosomal protein S14

Chain S:  98% ..

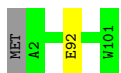

- Molecule 33: 30S ribosomal protein S15

Chain T:  98% ..



- Molecule 34: 30S ribosomal protein S16

Chain U:  98% .

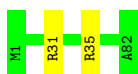

- Molecule 35: 30S ribosomal protein S17

Chain V:  94% . 5%

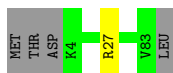

- Molecule 36: 30S ribosomal protein S19

Chain W:  87% . 10%

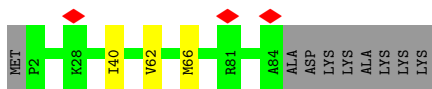

- Molecule 37: 30S ribosomal protein S13

Chain X:  95% ..

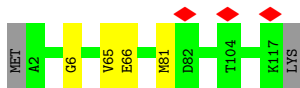

- Molecule 38: 50S ribosomal protein L11

Chain Y:  24% 98% ...

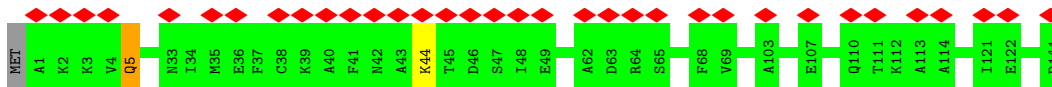

- Molecule 39: 50S ribosomal protein L7/L12



MET	SI	M26	E27	F30	GLY	VAL	ALA	SER	ALA	LYS	ALA	VAL	ASP	ALA	ALA	ALA	PRO	GLU	VAL	GLU	GLU	GLU	THR	ALA	GLY	PHE	ASP	VAL	ILE	LEU	LYS	ALA	ALA	GLY	ALA	ASN	LYS	VAL	VAL	VAL	ILE	LYS	ALA	VAL	ARG	ALA	ALA	THR	GLY	LEU	LEU	LYS	GLU	ALA
-----	----	-----	-----	-----	-----	-----	-----	-----	-----	-----	-----	-----	-----	-----	-----	-----	-----	-----	-----	-----	-----	-----	-----	-----	-----	-----	-----	-----	-----	-----	-----	-----	-----	-----	-----	-----	-----	-----	-----	-----	-----	-----	-----	-----	-----	-----	-----	-----	-----	-----	-----	-----	-----	-----

• Molecule 40: 23S rRNA

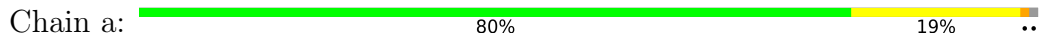

G1	U4	A10	G15	G23	G27	U34	G35	C46	G58	U59	U60	C61	U62	A63	U67	A71	A74	G75	A83	A84	G85	C96	A101	U102	A103	G110	A118	A119	U120	C130	A131	G136	U139	C140	G141	C163	C164	A165	A181	A196	G215	A216	A221	A222	C225	G248	C249	C253	G261	U59	C264	A265	G266	C267	G271	A272	C275	U276	G277	A278	G285	G291	A311	G329	A330	G110	A118	A119	U120	C130	A131	G136	U139	C140	G141	C163	C164	A165	G411	A412	C420	G424	U451	A457	A477	G481	G491	A501	A503	A504	A505	C509	G520	U521	A522	A529	G530	A532	G537	C542	G543	C544	U545	U546	A547	G548	G549	C551	A563	U569	U573	A574	C383	C384	C385	G386	G588	A603	A609	A613	A614	U615	A616	A626	A627	A637	C645	U646	G647	A654	A668	U686	G704	U710	C717	U521	A522	A529	G530	A532	G537	C542	G543	C544	U545	U546	A547	G548	G549	C551	A563	U569	U573	A574	C383	C384	C385	G386	G588	A603	U819	U827	U828	A845	U846	G858	G859	G869	A878	G881	G882	G883	U884	C885	C888	G891	A892	U894	U895	A896	C897	C898	A899	G907	A910	G914	C915	U931	A941	G942	A945	C946	G953	G954	U956	A960	C961	G974	A983	C995	A996	U999	C1005	U1012	C1013	U1019	A1020	C1022	U1023	G1026	U1033	G1041	C1045	A1046	G1047	C1053	U1060	U1061	C1064	U1065	U1066	A1067	G1068	A1069	U1070	C1072	A1073	G1074	C1079	A1080	U1081	U1082	U1083	A1084	U1085	A1086	G1087	A1088	A1089	A1090	A1095	U1101	G1107	A1111	G1112	U1119	G1122	G1128	U1132	A1133	A1134	C1135	U1141	A1142	A1169	C1170	U1173	U1174	A1175	U1176	G1177	G1178	G1179	U1180	G1186	G1225	G1238	G1248	A1253	G1256	C1257	G1266	G1271	A1272	U1273	A1276	G1300	A1301	A1321	G1331	G1334	C1345	U1352	A1365	G1368	A1378	U1379	G1380	A1383	A1392	A1395	U1406	G1407	U1409	C1414	U1415	G1416	G1417	G1418	A1419	A1420	C1428	G1452	A1453	U1460	G1482	A1490	U1497	A1503	A1508	A1509	G1510	A1515	G1529	G1530	U1534	A1535	C1536	G1537	U1554	U1559	A1566	U1569	C1577	U1578	A1579	U1580	U1581	C1582	A1583	U1584	C1585	U1589	A1590	A1608	U1609	A1610	G1613	A1617	G1619	U1647	G1648	U1649	A1650	G1651	A1655	A1665	G1674	A1677	G1703	U1714	G1715	U1729	C1730	G1731	C1732	G1738	G1750	U1758	C1764	A1773	U1775	A1791	C1800	A1808	G1811	G1816	U1817	U1818	A1829	C1833	U1834	G	G1836	A1847	A1848	G1857	U1858	U1859	G1862	G1863	U1864	G1869	C1870	A1871	A1872	G1873	G1906	G1907	G1910	U	A1912	A1913	C1914	U1916	A1918	A1919	C1920	G1921	A2013	A2020	U2022	C2023	G2027	U2028	G2029	A	A2031	G2032	A2033	C2043	G2049	C2050	A2051	A2052
----	----	-----	-----	-----	-----	-----	-----	-----	-----	-----	-----	-----	-----	-----	-----	-----	-----	-----	-----	-----	-----	-----	------	------	------	------	------	------	------	------	------	------	------	------	------	------	------	------	------	------	------	------	------	------	------	------	------	------	------	-----	------	------	------	------	------	------	------	------	------	------	------	------	------	------	------	------	------	------	------	------	------	------	------	------	------	------	------	------	------	------	------	------	------	------	------	------	------	------	------	------	------	------	------	------	------	------	------	------	------	------	------	------	------	------	------	------	------	------	------	------	------	------	------	------	------	------	------	------	------	------	------	------	------	------	------	------	------	------	------	------	------	------	------	------	------	------	------	------	------	------	------	------	------	------	------	------	------	------	------	------	------	------	------	------	------	------	------	------	------	------	------	------	------	------	------	------	------	------	------	------	------	------	------	------	------	------	------	------	------	------	------	------	------	------	------	------	------	------	------	------	------	------	------	------	------	------	------	------	------	------	------	------	-------	-------	-------	-------	-------	-------	-------	-------	-------	-------	-------	-------	-------	-------	-------	-------	-------	-------	-------	-------	-------	-------	-------	-------	-------	-------	-------	-------	-------	-------	-------	-------	-------	-------	-------	-------	-------	-------	-------	-------	-------	-------	-------	-------	-------	-------	-------	-------	-------	-------	-------	-------	-------	-------	-------	-------	-------	-------	-------	-------	-------	-------	-------	-------	-------	-------	-------	-------	-------	-------	-------	-------	-------	-------	-------	-------	-------	-------	-------	-------	-------	-------	-------	-------	-------	-------	-------	-------	-------	-------	-------	-------	-------	-------	-------	-------	-------	-------	-------	-------	-------	-------	-------	-------	-------	-------	-------	-------	-------	-------	-------	-------	-------	-------	-------	-------	-------	-------	-------	-------	-------	-------	-------	-------	-------	-------	-------	-------	-------	-------	-------	-------	-------	-------	-------	-------	-------	-------	-------	-------	-------	-------	-------	-------	-------	-------	-------	-------	-------	-------	-------	-------	-------	-------	-------	-------	-------	-------	-------	-------	-------	-------	-------	-------	-------	-------	-------	-------	-------	-------	---	-------	-------	-------	-------	-------	-------	-------	-------	-------	-------	-------	-------	-------	-------	-------	-------	-------	---	-------	-------	-------	-------	-------	-------	-------	-------	-------	-------	-------	-------	-------	-------	-------	---	-------	-------	-------	-------	-------	-------	-------	-------

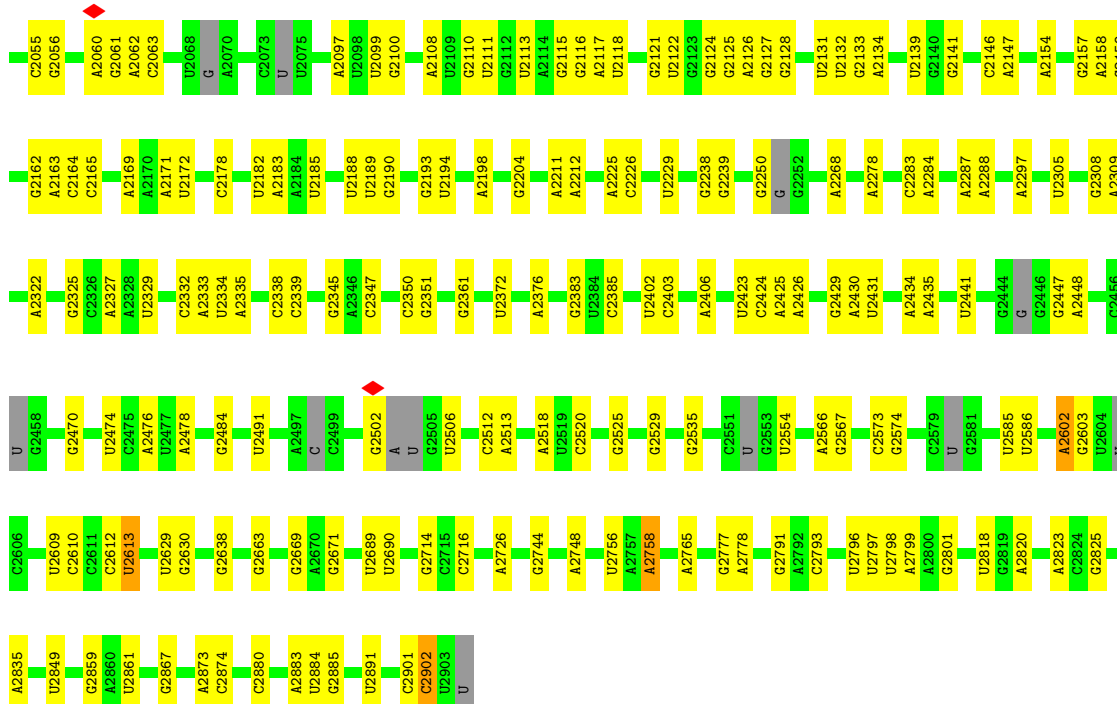

• Molecule 41: 50S ribosomal protein L27

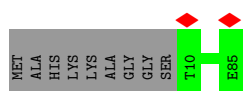
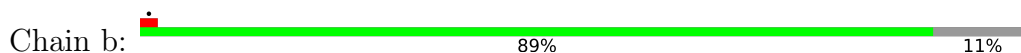

• Molecule 42: 50S ribosomal protein L28



• Molecule 43: 5S rRNA

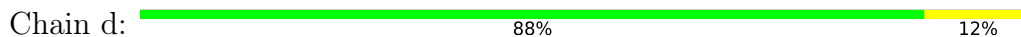

• Molecule 44: 50S ribosomal protein L29



- Molecule 45: 50S ribosomal protein L30

Chain f:  97%



- Molecule 46: 50S ribosomal protein L31

Chain g:  93%



- Molecule 47: 50S ribosomal protein L2

Chain h:  98%

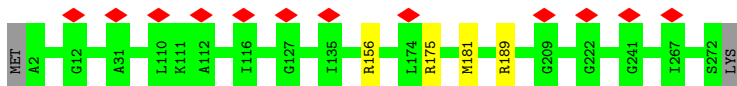

- Molecule 48: 50S ribosomal protein L32

Chain i:  96%

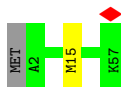

- Molecule 49: 50S ribosomal protein L3

Chain j:  99%

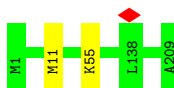

- Molecule 50: 50S ribosomal protein L33

Chain k:  95%

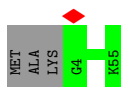

- Molecule 51: 50S ribosomal protein L4

Chain l:  99%

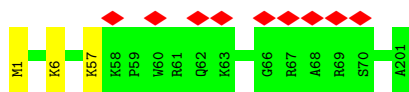

- Molecule 52: 50S ribosomal protein L34

Chain m: 100%



- Molecule 53: 50S ribosomal protein L5

Chain n: 97%

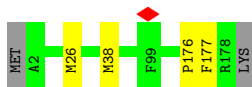

- Molecule 54: 50S ribosomal protein L35

Chain o: 94% 5%



- Molecule 55: 50S ribosomal protein L6

Chain p: 98%



- Molecule 56: 50S ribosomal protein L36

Chain q: 100%

There are no outlier residues recorded for this chain.

- Molecule 57: 50S ribosomal protein L9

Chain r: 7% 100%

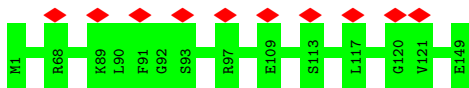

- Molecule 58: 50S ribosomal protein L13

Chain s: 97%

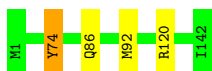

- Molecule 59: 50S ribosomal protein L14

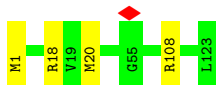

- Molecule 60: 50S ribosomal protein L15

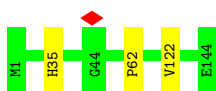

- Molecule 61: 50S ribosomal protein L16



- Molecule 62: 50S ribosomal protein L17



- Molecule 63: 50S ribosomal protein L18



- Molecule 64: 50S ribosomal protein L19

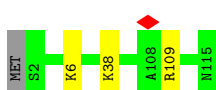

- Molecule 65: 50S ribosomal protein L20





4 Experimental information

Property	Value	Source
EM reconstruction method	SINGLE PARTICLE	Depositor
Imposed symmetry	POINT, Not provided	
Number of particles used	35602	Depositor
Resolution determination method	FSC 0.143 CUT-OFF	Depositor
CTF correction method	PHASE FLIPPING AND AMPLITUDE CORRECTION	Depositor
Microscope	FEI TALOS ARCTICA	Depositor
Voltage (kV)	200	Depositor
Electron dose ($e^-/\text{\AA}^2$)	28	Depositor
Minimum defocus (nm)	1250	Depositor
Maximum defocus (nm)	2500	Depositor
Magnification	Not provided	
Image detector	GATAN K2 SUMMIT (4k x 4k)	Depositor
Maximum map value	0.026	Depositor
Minimum map value	-0.009	Depositor
Average map value	-0.000	Depositor
Map value standard deviation	0.002	Depositor
Recommended contour level	0.002	Depositor
Map size (Å)	459.8208, 459.8208, 459.8208	wwPDB
Map dimensions	576, 576, 576	wwPDB
Map angles (°)	90.0, 90.0, 90.0	wwPDB
Pixel spacing (Å)	0.7983, 0.7983, 0.7983	Depositor

5 Model quality i

5.1 Standard geometry i

Bond lengths and bond angles in the following residue types are not validated in this section: ZN, MG

The Z score for a bond length (or angle) is the number of standard deviations the observed value is removed from the expected value. A bond length (or angle) with $|Z| > 5$ is considered an outlier worth inspection. RMSZ is the root-mean-square of all Z scores of the bond lengths (or angles).

Mol	Chain	Bond lengths		Bond angles	
		RMSZ	# Z >5	RMSZ	# Z >5
1	0	0.47	0/829	0.60	0/1107
2	1	0.58	0/864	0.69	0/1156
3	2	0.67	1/752 (0.1%)	0.72	1/1005 (0.1%)
4	3	0.41	0/796	0.55	0/1062
5	4	0.65	2/766 (0.3%)	0.69	0/1025
6	5	1.16	11/712 (1.5%)	1.12	1/1094 (0.1%)
7	6	1.12	8/786 (1.0%)	1.15	2/1206 (0.2%)
8	7	0.54	2/856 (0.2%)	0.89	4/1326 (0.3%)
9	9	0.36	0/1131	0.66	2/1524 (0.1%)
10	A	0.55	1/1810 (0.1%)	1.26	12/2821 (0.4%)
10	B	0.55	1/1810 (0.1%)	1.26	11/2821 (0.4%)
11	AA	0.43	0/10547	0.61	2/14232 (0.0%)
12	AB	0.61	0/1317	0.60	0/1786
13	AC	0.41	0/1718	0.62	0/2328
13	AD	0.36	0/1696	0.63	0/2298
14	AE	0.42	0/10561	0.63	3/14258 (0.0%)
15	AF	0.34	0/652	0.57	0/879
16	C	0.70	0/553	0.92	4/743 (0.5%)
17	D	0.59	13/36610 (0.0%)	1.03	68/57091 (0.1%)
18	E	0.57	0/675	0.71	0/895
19	F	0.62	0/597	0.59	0/792
20	G	0.66	2/1791 (0.1%)	0.83	8/2413 (0.3%)
21	H	0.43	0/1746	0.70	0/2382
22	I	0.62	2/1663 (0.1%)	0.71	4/2241 (0.2%)
23	J	0.54	2/1665 (0.1%)	0.59	0/2227
24	K	0.69	1/1165 (0.1%)	0.86	4/1568 (0.3%)
25	L	0.79	3/867 (0.3%)	0.82	3/1171 (0.3%)
26	M	0.54	0/1195	0.69	2/1602 (0.1%)
27	N	0.52	0/989	0.63	1/1326 (0.1%)
28	O	0.67	4/1034 (0.4%)	0.82	4/1375 (0.3%)
29	P	0.51	0/800	0.67	1/1082 (0.1%)
30	Q	0.71	1/893 (0.1%)	0.82	4/1205 (0.3%)

Mol	Chain	Bond lengths		Bond angles	
		RMSZ	# Z >5	RMSZ	# Z >5
31	R	0.56	0/952	0.65	0/1274
32	S	0.63	1/817 (0.1%)	0.64	0/1088
33	T	0.56	0/722	0.72	1/964 (0.1%)
34	U	0.45	0/659	0.65	1/884 (0.1%)
35	V	0.56	0/657	0.70	0/881
36	W	0.56	1/680 (0.1%)	0.69	3/915 (0.3%)
37	X	0.48	0/909	0.72	1/1215 (0.1%)
38	Y	0.42	1/1046 (0.1%)	0.57	2/1410 (0.1%)
39	Z	0.23	0/227	0.38	0/304
40	a	0.61	15/69247 (0.0%)	1.03	131/107985 (0.1%)
41	b	0.47	0/589	0.57	0/779
42	c	0.57	1/635 (0.2%)	0.66	1/848 (0.1%)
43	d	0.50	0/2872	0.95	0/4478
44	e	0.81	2/502 (0.4%)	0.67	0/667
45	f	0.53	0/452	0.72	2/605 (0.3%)
46	g	0.50	1/531 (0.2%)	0.67	1/709 (0.1%)
47	h	0.53	2/2121 (0.1%)	0.67	6/2852 (0.2%)
48	i	0.42	0/450	0.65	1/599 (0.2%)
49	j	0.53	0/1586	0.64	2/2134 (0.1%)
50	k	0.51	0/433	0.68	0/576
51	l	0.54	1/1571 (0.1%)	0.64	1/2113 (0.0%)
52	m	0.43	0/380	0.60	0/498
53	n	0.51	0/1434	0.68	2/1926 (0.1%)
54	o	0.51	0/513	0.85	1/676 (0.1%)
55	p	0.50	0/1333	0.68	3/1805 (0.2%)
56	q	0.46	0/303	0.60	0/397
57	r	0.34	0/1122	0.52	0/1515
58	s	0.83	5/1152 (0.4%)	0.81	4/1551 (0.3%)
59	t	0.55	1/955 (0.1%)	0.89	5/1279 (0.4%)
60	u	0.47	1/1062 (0.1%)	0.63	0/1413
61	v	0.61	1/1093 (0.1%)	0.75	1/1460 (0.1%)
62	w	0.90	5/964 (0.5%)	0.95	9/1289 (0.7%)
63	x	0.42	0/902	0.57	0/1209
64	y	0.46	0/929	0.59	1/1242 (0.1%)
65	z	0.63	1/960 (0.1%)	0.60	0/1278
All	All	0.58	93/190606 (0.0%)	0.92	320/280859 (0.1%)

Chiral center outliers are detected by calculating the chiral volume of a chiral center and verifying if the center is modelled as a planar moiety or with the opposite hand. A planarity outlier is detected by checking planarity of atoms in a peptide group, atoms in a mainchain group or atoms of a sidechain that are expected to be planar.

Mol	Chain	#Chirality outliers	#Planarity outliers
9	9	0	3
13	AC	0	1
13	AD	0	1
14	AE	0	4
20	G	0	1
21	H	0	5
22	I	0	1
24	K	0	2
28	O	0	1
37	X	0	1
38	Y	0	1
53	n	0	1
54	o	0	1
58	s	0	1
60	u	0	2
All	All	0	26

All (93) bond length outliers are listed below:

Mol	Chain	Res	Type	Atoms	Z	Observed(Å)	Ideal(Å)
62	w	35	LYS	CE-NZ	-15.22	1.11	1.49
25	L	42	TRP	CB-CG	-12.35	1.28	1.50
3	2	5	GLU	CG-CD	-11.56	1.34	1.51
44	e	46	VAL	CB-CG1	-11.30	1.29	1.52
62	w	42	LYS	CD-CE	-10.78	1.24	1.51
24	K	45	ARG	CG-CD	9.48	1.75	1.51
17	D	718	A	N9-C4	-8.97	1.32	1.37
28	O	80	ARG	CD-NE	-8.78	1.31	1.46
58	s	74	TYR	CZ-OH	-8.70	1.23	1.37
58	s	74	TYR	CE2-CZ	-8.45	1.27	1.38
20	G	19	GLN	CB-CG	-8.42	1.29	1.52
40	a	1141	U	N3-C4	-7.95	1.31	1.38
58	s	74	TYR	CD1-CE1	-7.82	1.27	1.39
6	5	25	DA	C1'-N9	-7.58	1.36	1.47
62	w	112	TYR	CG-CD1	-7.50	1.29	1.39
8	7	40	G	C1'-N9	-7.42	1.36	1.46
40	a	1453	A	N9-C4	-7.36	1.33	1.37
6	5	18	DG	C1'-N9	-7.28	1.37	1.47
17	D	1339	A	N9-C4	-7.21	1.33	1.37
23	J	182	PHE	CE2-CZ	-7.17	1.23	1.37
17	D	563	A	C6-N1	-7.09	1.30	1.35
36	W	66	MET	CG-SD	-7.05	1.62	1.81
17	D	397	A	C6-N1	-6.88	1.30	1.35

Continued on next page...

Continued from previous page...

Mol	Chain	Res	Type	Atoms	Z	Observed(Å)	Ideal(Å)
7	6	9	DG	C1'-N9	-6.88	1.37	1.47
8	7	2	U	C1'-N1	6.86	1.59	1.48
51	l	6	LYS	CE-NZ	-6.84	1.31	1.49
6	5	21	DA	C1'-N9	-6.78	1.37	1.47
40	a	1019	U	N3-C4	-6.76	1.32	1.38
38	Y	5	GLN	CB-CG	-6.72	1.34	1.52
7	6	12	DG	C1'-N9	-6.66	1.38	1.47
17	D	872	A	C6-N1	-6.63	1.30	1.35
17	D	1363	A	C6-N1	-6.59	1.30	1.35
28	O	80	ARG	CZ-NH2	6.58	1.41	1.33
40	a	1021	A	C6-N1	-6.54	1.30	1.35
46	g	62	LYS	CE-NZ	-6.52	1.32	1.49
65	z	74	ILE	CB-CG2	-6.48	1.32	1.52
25	L	42	TRP	CZ3-CH2	-6.46	1.29	1.40
6	5	-3	DC	C1'-N1	6.35	1.57	1.49
22	I	166	GLU	CG-CD	-6.34	1.42	1.51
28	O	118	LEU	CG-CD2	-6.34	1.28	1.51
22	I	29	PHE	CD2-CE2	-6.33	1.26	1.39
25	L	42	TRP	CE3-CZ3	-6.32	1.27	1.38
40	a	67	U	C4-O4	-6.28	1.18	1.23
17	D	827	U	N3-C4	-6.27	1.32	1.38
20	G	158	PRO	CG-CD	6.25	1.71	1.50
6	5	-6	DC	C1'-N1	6.25	1.57	1.49
7	6	5	DG	C1'-N9	-6.24	1.38	1.47
40	a	1142	A	C6-N1	-6.22	1.31	1.35
10	B	37	A	N9-C4	-6.22	1.34	1.37
17	D	37	U	N3-C4	-6.21	1.32	1.38
10	A	37	A	N9-C4	-6.20	1.34	1.37
17	D	1358	U	N3-C4	-6.18	1.32	1.38
40	a	2013	A	C6-N6	-6.17	1.29	1.33
6	5	28	DG	C1'-N9	-6.15	1.38	1.47
6	5	27	DG	C1'-N9	-6.13	1.38	1.47
6	5	3	DC	C1'-N1	6.13	1.57	1.49
32	S	92	GLU	CD-OE1	-6.08	1.19	1.25
44	e	25	GLN	CB-CG	-5.97	1.36	1.52
47	h	181	MET	CG-SD	-5.94	1.65	1.81
58	s	92	MET	CG-SD	-5.88	1.65	1.81
40	a	2613	U	N3-C4	-5.84	1.33	1.38
62	w	35	LYS	CD-CE	5.84	1.65	1.51
17	D	872	A	C6-N6	-5.83	1.29	1.33
40	a	1257	C	N1-C2	-5.77	1.34	1.40
40	a	2756	U	C4-O4	-5.71	1.19	1.23

Continued on next page...

Continued from previous page...

Mol	Chain	Res	Type	Atoms	Z	Observed(Å)	Ideal(Å)
61	v	45	GLN	CB-CG	-5.68	1.37	1.52
5	4	56	PHE	CB-CG	-5.62	1.41	1.51
28	O	103	PHE	CE2-CZ	-5.62	1.26	1.37
40	a	2013	A	C6-N1	-5.60	1.31	1.35
17	D	884	U	N3-C4	-5.60	1.33	1.38
40	a	1082	U	C4-O4	-5.57	1.19	1.23
60	u	122	VAL	CB-CG1	-5.53	1.41	1.52
23	J	72	PHE	CB-CG	-5.53	1.42	1.51
42	c	70	GLU	CG-CD	-5.52	1.43	1.51
58	s	74	TYR	CD2-CE2	-5.50	1.31	1.39
47	h	175	ARG	CB-CG	5.48	1.67	1.52
5	4	75	GLN	CB-CG	-5.43	1.37	1.52
17	D	563	A	C6-N6	-5.42	1.29	1.33
30	Q	106	ARG	CD-NE	-5.39	1.37	1.46
6	5	-4	DT	C1'-N1	5.29	1.56	1.49
17	D	397	A	C6-N6	-5.27	1.29	1.33
59	t	18	ARG	CZ-NH1	-5.23	1.26	1.33
62	w	80	PHE	CB-CG	-5.23	1.42	1.51
7	6	29	DC	C1'-N1	5.21	1.56	1.49
40	a	1021	A	C6-N6	-5.18	1.29	1.33
7	6	34	DC	C1'-N1	5.17	1.55	1.49
7	6	25	DT	C1'-N1	5.15	1.55	1.49
7	6	28	DT	C1'-N1	5.14	1.55	1.49
7	6	10	DG	C1'-N9	-5.13	1.40	1.47
40	a	2613	U	C4-O4	-5.12	1.19	1.23
6	5	-1	DT	C1'-N1	5.11	1.55	1.49
6	5	2	DT	C1'-N1	5.09	1.55	1.49
40	a	1655	A	N9-C4	-5.04	1.34	1.37

All (320) bond angle outliers are listed below:

Mol	Chain	Res	Type	Atoms	Z	Observed(°)	Ideal(°)
40	a	1019	U	C5-C4-O4	30.70	144.32	125.90
40	a	1141	U	C5-C4-O4	29.46	143.57	125.90
17	D	37	U	C5-C4-O4	29.37	143.52	125.90
17	D	1358	U	C5-C4-O4	29.29	143.47	125.90
17	D	827	U	C5-C4-O4	28.61	143.07	125.90
17	D	37	U	N3-C4-O4	-28.37	99.54	119.40
17	D	827	U	N3-C4-O4	-27.48	100.16	119.40
40	a	1019	U	N3-C4-O4	-27.31	100.28	119.40
17	D	1358	U	N3-C4-O4	-27.14	100.40	119.40
40	a	2613	U	C5-C4-O4	26.19	141.61	125.90

Continued on next page...

Continued from previous page...

Mol	Chain	Res	Type	Atoms	Z	Observed(°)	Ideal(°)
40	a	2613	U	N3-C4-O4	-25.48	101.57	119.40
40	a	1082	U	N3-C4-O4	-25.41	101.61	119.40
17	D	884	U	C5-C4-O4	25.39	141.13	125.90
17	D	884	U	N3-C4-O4	-24.73	102.09	119.40
40	a	1082	U	C5-C4-O4	23.84	140.20	125.90
40	a	1141	U	N3-C4-O4	-23.68	102.83	119.40
40	a	1257	C	C6-N1-C2	20.07	128.33	120.30
17	D	872	A	N1-C6-N6	-17.65	108.01	118.60
40	a	1021	A	N1-C6-N6	-17.21	108.28	118.60
17	D	563	A	N1-C6-N6	-16.98	108.41	118.60
17	D	397	A	N1-C6-N6	-16.60	108.64	118.60
40	a	1141	U	C2-N3-C4	16.57	136.94	127.00
40	a	1142	A	N1-C6-N6	-16.23	108.86	118.60
40	a	2756	U	N3-C4-O4	-16.08	108.14	119.40
17	D	1363	A	N1-C6-N6	-15.82	109.11	118.60
40	a	67	U	N3-C4-O4	-15.17	108.78	119.40
24	K	71	MET	CG-SD-CE	-15.12	76.01	100.20
40	a	2013	A	N1-C6-N6	-15.03	109.58	118.60
62	w	112	TYR	CZ-CE2-CD2	-14.93	106.36	119.80
10	A	39	C	C4-C5-C6	14.78	124.79	117.40
40	a	1019	U	C2-N3-C4	14.76	135.86	127.00
10	B	39	C	C4-C5-C6	14.68	124.74	117.40
40	a	1086	A	N1-C6-N6	-14.55	109.87	118.60
20	G	113	ARG	NE-CZ-NH2	14.43	127.51	120.30
40	a	1019	U	N1-C2-N3	-12.92	107.15	114.90
54	o	30	ARG	NE-CZ-NH1	-12.76	113.92	120.30
58	s	92	MET	CG-SD-CE	-12.43	80.31	100.20
10	A	39	C	N3-C4-C5	-12.29	116.98	121.90
59	t	18	ARG	NE-CZ-NH2	12.29	126.45	120.30
40	a	1141	U	N1-C2-N3	-12.28	107.53	114.90
10	B	39	C	N3-C4-C5	-12.03	117.09	121.90
59	t	18	ARG	NE-CZ-NH1	-11.64	114.48	120.30
16	C	73	ARG	NE-CZ-NH2	11.34	125.97	120.30
17	D	1358	U	C2-N3-C4	11.14	133.68	127.00
17	D	718	A	N3-C4-C5	11.07	134.55	126.80
40	a	2756	U	C5-C4-O4	11.01	132.51	125.90
40	a	960	A	N1-C6-N6	11.01	125.20	118.60
20	G	158	PRO	N-CD-CG	-10.99	86.71	103.20
25	L	102	MET	CA-CB-CG	-10.83	94.89	113.30
17	D	1358	U	N1-C2-N3	-10.67	108.50	114.90
40	a	1021	A	C5-C6-N6	10.65	132.22	123.70
40	a	1142	A	C5-C6-N6	10.53	132.12	123.70

Continued on next page...

Continued from previous page...

Mol	Chain	Res	Type	Atoms	Z	Observed(°)	Ideal(°)
17	D	397	A	C5-C6-N6	10.33	131.97	123.70
40	a	960	A	C5-C6-N6	-10.16	115.57	123.70
17	D	872	A	C5-C6-N6	9.94	131.66	123.70
17	D	1363	A	C5-C6-N6	9.86	131.59	123.70
17	D	827	U	N1-C2-N3	-9.83	109.00	114.90
62	w	112	TYR	CB-CG-CD2	-9.58	115.25	121.00
17	D	563	A	C5-C6-N6	9.58	131.36	123.70
40	a	67	U	C5-C4-O4	9.54	131.63	125.90
7	6	23	DT	O5'-P-OP2	-9.36	97.27	105.70
17	D	718	A	C4-C5-C6	-9.27	112.36	117.00
28	O	103	PHE	CD1-CE1-CZ	-9.11	109.17	120.10
17	D	827	U	C2-N3-C4	9.04	132.43	127.00
20	G	157	LEU	C-N-CD	-8.97	100.87	120.60
40	a	1257	C	O4'-C1'-N1	-8.88	101.10	108.20
40	a	1021	A	N1-C2-N3	-8.71	124.94	129.30
40	a	1060	U	N3-C4-O4	8.59	125.42	119.40
40	a	1019	U	C4-C5-C6	-8.52	114.59	119.70
61	v	10	ARG	NE-CZ-NH1	-8.50	116.05	120.30
40	a	1060	U	C5-C4-O4	-8.46	120.83	125.90
30	Q	106	ARG	NE-CZ-NH1	-8.45	116.08	120.30
40	a	1775	U	C5-C4-O4	-8.43	120.84	125.90
40	a	1257	C	C5-C6-N1	-8.40	116.80	121.00
33	T	89	ARG	NE-CZ-NH2	-8.29	116.15	120.30
17	D	718	A	N3-C4-N9	-8.29	120.77	127.40
17	D	718	A	N1-C2-N3	-8.25	125.17	129.30
14	AE	710	ASP	CB-CG-OD1	8.20	125.68	118.30
40	a	2334	U	OP2-P-O3'	-8.19	87.17	105.20
40	a	2012	G	O5'-P-OP1	-8.13	98.39	105.70
17	D	1125	U	C5-C4-O4	-8.08	121.05	125.90
30	Q	56	ARG	NE-CZ-NH1	8.07	124.34	120.30
10	B	76	A	N1-C6-N6	-8.06	113.76	118.60
9	9	129	LEU	C-N-CD	-8.06	102.88	120.60
24	K	78	ASN	N-CA-CB	-8.05	96.11	110.60
45	f	45	ARG	NE-CZ-NH1	8.05	124.32	120.30
17	D	884	U	N1-C2-N3	-8.03	110.08	114.90
10	A	76	A	N1-C6-N6	-8.01	113.80	118.60
17	D	37	U	N1-C2-N3	-8.00	110.10	114.90
28	O	80	ARG	CG-CD-NE	7.83	128.24	111.80
34	U	31	ARG	NE-CZ-NH2	-7.80	116.40	120.30
40	a	1257	C	N3-C4-C5	7.78	125.01	121.90
17	D	884	U	C2-N3-C4	7.77	131.66	127.00
40	a	1530	G	C5-C6-O6	-7.72	123.97	128.60

Continued on next page...

Continued from previous page...

Mol	Chain	Res	Type	Atoms	Z	Observed(°)	Ideal(°)
17	D	718	A	C6-N1-C2	7.57	123.14	118.60
40	a	626	A	N1-C6-N6	-7.56	114.06	118.60
37	X	81	MET	CG-SD-CE	-7.54	88.13	100.20
10	A	37	A	C2-N3-C4	-7.54	106.83	110.60
17	D	397	A	N1-C2-N3	-7.54	125.53	129.30
17	D	827	U	C4-C5-C6	-7.45	115.23	119.70
10	B	37	A	C2-N3-C4	-7.43	106.88	110.60
62	w	38	LEU	CB-CG-CD1	-7.38	98.46	111.00
40	a	626	A	N1-C2-N3	7.37	132.99	129.30
62	w	112	TYR	OH-CZ-CE2	-7.37	100.20	120.10
22	I	134	MET	CG-SD-CE	-7.35	88.45	100.20
22	I	166	GLU	OE1-CD-OE2	7.34	132.10	123.30
28	O	103	PHE	CG-CD1-CE1	7.33	128.87	120.80
20	G	154	MET	CG-SD-CE	-7.28	88.55	100.20
17	D	1358	U	C4-C5-C6	-7.27	115.34	119.70
40	a	1086	A	C5-C6-N6	7.27	129.51	123.70
10	A	39	C	C5-C6-N1	-7.25	117.37	121.00
40	a	1530	G	N1-C6-O6	7.24	124.24	119.90
40	a	1276	A	C8-N9-C4	7.23	108.69	105.80
40	a	1655	A	C8-N9-C4	7.22	108.69	105.80
10	B	39	C	C5-C6-N1	-7.21	117.39	121.00
40	a	1453	A	C2-N3-C4	-7.19	107.01	110.60
8	7	1	A	OP2-P-O3'	7.17	120.98	105.20
17	D	37	U	C2-N3-C4	7.16	131.29	127.00
40	a	1581	G	N9-C4-C5	-7.13	102.55	105.40
40	a	2013	A	C5-C6-N6	7.13	129.40	123.70
17	D	1125	U	N3-C4-O4	7.12	124.38	119.40
10	A	37	A	C5-N7-C8	-7.08	100.36	103.90
40	a	1775	U	N3-C4-O4	7.08	124.36	119.40
22	I	134	MET	CB-CG-SD	-7.08	91.16	112.40
40	a	2902	C	C2-N1-C1'	-7.06	111.03	118.80
10	A	37	A	N1-C2-N3	7.01	132.81	129.30
40	a	2612	C	C6-N1-C2	6.95	123.08	120.30
40	a	1453	A	N3-C4-C5	6.94	131.66	126.80
40	a	960	A	N9-C4-C5	-6.92	103.03	105.80
10	B	37	A	N1-C2-N3	6.89	132.75	129.30
40	a	542	C	C6-N1-C2	6.88	123.05	120.30
10	B	37	A	C5-N7-C8	-6.87	100.47	103.90
46	g	62	LYS	CD-CE-NZ	-6.85	95.94	111.70
17	D	37	U	C4-C5-C6	-6.83	115.60	119.70
17	D	1526	G	N3-C2-N2	-6.83	115.12	119.90
8	7	1	A	O3'-P-O5'	-6.81	91.06	104.00

Continued on next page...

Continued from previous page...

Mol	Chain	Res	Type	Atoms	Z	Observed(°)	Ideal(°)
16	C	38	LYS	CD-CE-NZ	-6.75	96.17	111.70
40	a	196	A	O4'-C1'-N9	6.72	113.58	108.20
40	a	2758	A	N1-C6-N6	-6.69	114.58	118.60
20	G	158	PRO	CA-N-CD	-6.68	102.14	111.50
20	G	19	GLN	CA-CB-CG	6.68	128.10	113.40
17	D	280	C	C2-N3-C4	6.68	123.24	119.90
62	w	42	LYS	CD-CE-NZ	6.67	127.04	111.70
40	a	960	A	C4-C5-N7	6.64	114.02	110.70
40	a	2013	A	C5-C6-N1	6.63	121.02	117.70
40	a	1453	A	C6-N1-C2	6.61	122.57	118.60
40	a	1818	U	C5-C6-N1	6.60	126.00	122.70
17	D	476	U	C5-C4-O4	-6.49	122.00	125.90
40	a	2188	U	C5-C4-O4	-6.45	122.03	125.90
47	h	181	MET	CG-SD-CE	-6.44	89.90	100.20
40	a	2351	G	C5-C6-O6	-6.42	124.75	128.60
40	a	2756	U	N1-C2-N3	-6.40	111.06	114.90
17	D	280	C	C5-C6-N1	6.37	124.18	121.00
40	a	1082	U	C4-C5-C6	-6.36	115.88	119.70
51	l	1	MET	CG-SD-CE	-6.35	90.04	100.20
40	a	1581	G	C4-C5-N7	6.35	113.34	110.80
17	D	718	A	C8-N9-C4	6.34	108.34	105.80
17	D	1339	A	N3-C4-N9	-6.32	122.35	127.40
11	AA	478	ARG	C-N-CA	-6.28	106.00	121.70
20	G	154	MET	CA-CB-CG	-6.27	102.64	113.30
17	D	884	U	C4-C5-C6	-6.27	115.94	119.70
28	O	80	ARG	CB-CG-CD	-6.24	95.37	111.60
36	W	40	ILE	CG1-CB-CG2	6.24	125.12	111.40
55	p	152	ARG	NE-CZ-NH1	-6.20	117.20	120.30
58	s	92	MET	CB-CG-SD	-6.20	93.81	112.40
40	a	1276	A	N9-C4-C5	-6.19	103.32	105.80
10	A	31	G	O4'-C1'-N9	6.19	113.15	108.20
40	a	942	G	N1-C6-O6	-6.19	116.19	119.90
10	B	31	G	O4'-C1'-N9	6.14	113.11	108.20
17	D	60	A	O4'-C1'-N9	6.14	113.11	108.20
17	D	476	U	N3-C4-O4	6.14	123.70	119.40
17	D	718	A	P-O5'-C5'	-6.13	111.09	120.90
47	h	175	ARG	NE-CZ-NH2	-6.12	117.24	120.30
48	i	15	MET	CG-SD-CE	-6.12	90.41	100.20
40	a	1257	C	N3-C2-O2	6.11	126.18	121.90
45	f	45	ARG	NE-CZ-NH2	-6.11	117.25	120.30
40	a	2902	C	C6-N1-C2	6.09	122.73	120.30
58	s	120	ARG	NE-CZ-NH1	-6.06	117.27	120.30

Continued on next page...

Continued from previous page...

Mol	Chain	Res	Type	Atoms	Z	Observed(°)	Ideal(°)
17	D	1363	A	N9-C4-C5	-6.05	103.38	105.80
40	a	2638	G	O4'-C1'-N9	6.03	113.02	108.20
62	w	112	TYR	CG-CD1-CE1	-6.03	116.48	121.30
40	a	893	C	C2-N3-C4	-6.02	116.89	119.90
40	a	2901	C	C6-N1-C2	6.01	122.70	120.30
40	a	2613	U	C4-C5-C6	-5.98	116.11	119.70
36	W	40	ILE	CA-CB-CG1	-5.96	99.68	111.00
14	AE	363	LEU	CA-CB-CG	5.95	128.99	115.30
62	w	38	LEU	CB-CG-CD2	5.95	121.12	111.00
40	a	729	G	O4'-C1'-N9	5.94	112.95	108.20
40	a	686	U	N3-C4-C5	5.92	118.15	114.60
40	a	1257	C	N1-C2-N3	-5.92	115.06	119.20
40	a	2351	G	C4-C5-N7	5.92	113.17	110.80
40	a	1581	G	N1-C6-O6	5.91	123.45	119.90
47	h	156	ARG	NE-CZ-NH1	5.89	123.25	120.30
40	a	2602	A	C3'-C2'-C1'	5.88	106.20	101.50
17	D	915	A	N9-C4-C5	-5.85	103.46	105.80
55	p	164	TYR	CB-CG-CD2	5.84	124.50	121.00
40	a	2334	U	OP1-P-O3'	5.83	118.02	105.20
49	j	55	LYS	CD-CE-NZ	-5.83	98.30	111.70
40	a	1019	U	N3-C2-O2	5.82	126.28	122.20
40	a	2756	U	C4-C5-C6	-5.82	116.21	119.70
17	D	280	C	N1-C2-O2	5.81	122.39	118.90
26	M	4	ARG	NE-CZ-NH1	-5.81	117.40	120.30
17	D	1344	C	O5'-P-OP1	-5.80	100.48	105.70
40	a	136	G	N9-C4-C5	-5.80	103.08	105.40
26	M	47	LEU	CB-CG-CD2	-5.79	101.16	111.00
16	C	73	ARG	NE-CZ-NH1	-5.77	117.41	120.30
40	a	1086	A	C5-C6-N1	5.77	120.58	117.70
40	a	1577	C	C6-N1-C2	5.76	122.60	120.30
47	h	175	ARG	NE-CZ-NH1	5.76	123.18	120.30
17	D	563	A	N9-C4-C5	-5.75	103.50	105.80
59	t	18	ARG	CG-CD-NE	-5.72	99.79	111.80
40	a	942	G	C5-C6-O6	5.71	132.02	128.60
40	a	542	C	N3-C4-C5	5.70	124.18	121.90
40	a	2049	G	N3-C2-N2	-5.70	115.91	119.90
40	a	2329	U	C5-C6-N1	5.70	125.55	122.70
40	a	686	U	N3-C4-O4	-5.70	115.41	119.40
40	a	1857	G	O4'-C1'-N9	5.70	112.76	108.20
25	L	45	ARG	NE-CZ-NH2	-5.69	117.45	120.30
40	a	1334	G	N3-C4-C5	5.69	131.45	128.60
47	h	189	ARG	NE-CZ-NH2	5.68	123.14	120.30

Continued on next page...

Continued from previous page...

Mol	Chain	Res	Type	Atoms	Z	Observed(°)	Ideal(°)
40	a	1141	U	C4-C5-C6	-5.65	116.31	119.70
17	D	526	C	C6-N1-C2	5.64	122.56	120.30
29	P	85	ASP	CB-CG-OD2	-5.63	113.23	118.30
40	a	2188	U	N3-C4-O4	5.63	123.34	119.40
40	a	1142	A	N1-C2-N3	-5.63	126.48	129.30
40	a	1082	U	N1-C2-N3	-5.61	111.53	114.90
40	a	974	G	O4'-C1'-N9	5.59	112.67	108.20
30	Q	110	ILE	CG1-CB-CG2	-5.58	99.12	111.40
17	D	719	C	C6-N1-C2	5.57	122.53	120.30
16	C	60	LYS	CD-CE-NZ	-5.57	98.89	111.70
40	a	1225	G	N3-C4-C5	5.56	131.38	128.60
40	a	544	C	C6-N1-C2	5.56	122.52	120.30
10	A	23	C	N1-C2-O2	5.54	122.22	118.90
40	a	1414	C	C2-N1-C1'	-5.52	112.72	118.80
47	h	156	ARG	NE-CZ-NH2	-5.52	117.54	120.30
59	t	1	MET	CG-SD-CE	-5.50	91.41	100.20
14	AE	709	ARG	C-N-CA	5.48	135.39	121.70
42	c	71	LEU	CA-CB-CG	5.48	127.89	115.30
40	a	1021	A	C4-C5-C6	-5.47	114.27	117.00
40	a	253	C	C6-N1-C2	5.46	122.49	120.30
10	B	23	C	N1-C2-O2	5.46	122.18	118.90
17	D	1158	C	O4'-C1'-N1	5.46	112.57	108.20
17	D	1339	A	C2-N3-C4	-5.46	107.87	110.60
40	a	1141	U	N1-C2-O2	5.46	126.62	122.80
8	7	28	G	C2'-C3'-O3'	5.43	122.40	113.70
10	A	38	A	C5'-C4'-O4'	5.43	115.61	109.10
40	a	742	A	C6-N1-C2	-5.43	115.34	118.60
25	L	45	ARG	NE-CZ-NH1	5.42	123.01	120.30
49	j	11	MET	CB-CG-SD	-5.41	96.17	112.40
10	B	38	A	C5'-C4'-O4'	5.41	115.59	109.10
40	a	2338	C	C6-N1-C2	5.41	122.46	120.30
40	a	2332	C	C6-N1-C2	5.40	122.46	120.30
40	a	775	G	O4'-C1'-N9	5.40	112.52	108.20
64	y	109	ARG	NE-CZ-NH1	5.39	123.00	120.30
17	D	280	C	C5-C4-N4	5.38	123.97	120.20
40	a	883	G	N3-C2-N2	-5.38	116.13	119.90
10	A	37	A	N7-C8-N9	5.37	116.48	113.80
40	a	1021	A	C6-N1-C2	5.37	121.82	118.60
58	s	92	MET	CA-CB-CG	-5.36	104.19	113.30
40	a	1257	C	C6-N1-C1'	-5.36	114.37	120.80
40	a	1142	A	C4-C5-C6	-5.35	114.32	117.00
40	a	1581	G	C6-C5-N7	-5.35	127.19	130.40

Continued on next page...

Continued from previous page...

Mol	Chain	Res	Type	Atoms	Z	Observed(°)	Ideal(°)
40	a	221	A	O4'-C1'-N9	5.35	112.48	108.20
40	a	1019	U	N1-C2-O2	5.32	126.53	122.80
62	w	112	TYR	CE1-CZ-CE2	5.32	128.31	119.80
9	9	130	PRO	CA-N-CD	-5.32	104.06	111.50
3	2	69	ARG	NE-CZ-NH1	5.31	122.96	120.30
6	5	8	DT	P-O3'-C3'	5.31	126.08	119.70
22	I	168	TYR	N-CA-CB	5.31	120.16	110.60
40	a	385	C	C6-N1-C2	5.30	122.42	120.30
17	D	476	U	C2-N1-C1'	5.29	124.05	117.70
30	Q	56	ARG	NE-CZ-NH2	-5.29	117.66	120.30
40	a	542	C	C2-N1-C1'	-5.29	112.98	118.80
55	p	152	ARG	NE-CZ-NH2	5.29	122.94	120.30
40	a	1257	C	O5'-P-OP2	-5.26	100.96	105.70
17	D	872	A	C5-C6-N1	5.25	120.33	117.70
17	D	397	A	C4-C5-N7	5.25	113.32	110.70
40	a	67	U	N1-C2-N3	-5.24	111.75	114.90
36	W	62	VAL	CG1-CB-CG2	5.24	119.28	110.90
40	a	2613	U	C2-N3-C4	5.23	130.14	127.00
40	a	27	G	O4'-C1'-N9	5.22	112.38	108.20
38	Y	5	GLN	CB-CA-C	-5.22	99.97	110.40
59	t	20	MET	CA-CB-CG	5.22	122.17	113.30
40	a	1414	C	C6-N1-C2	5.21	122.38	120.30
53	n	26	MET	CG-SD-CE	-5.20	91.88	100.20
40	a	2756	U	N3-C4-C5	5.19	117.72	114.60
40	a	2901	C	C2-N1-C1'	-5.19	113.09	118.80
40	a	1053	C	C6-N1-C2	5.19	122.37	120.30
40	a	704	G	O4'-C1'-N9	5.17	112.34	108.20
40	a	2602	A	P-O3'-C3'	5.17	125.91	119.70
11	AA	516	ASP	CB-CG-OD2	5.17	122.95	118.30
17	D	496	A	C2-N3-C4	5.17	113.18	110.60
17	D	107	G	N9-C1'-C2'	-5.15	106.34	112.00
40	a	2013	A	N9-C4-C5	-5.15	103.74	105.80
27	N	27	MET	CG-SD-CE	-5.11	92.02	100.20
10	B	37	A	N7-C8-N9	5.11	116.36	113.80
40	a	1331	G	N1-C6-O6	-5.11	116.84	119.90
8	7	4	U	C2'-C3'-O3'	5.10	121.86	113.70
40	a	2284	A	C8-N9-C4	5.10	107.84	105.80
24	K	45	ARG	CB-CG-CD	-5.09	98.37	111.60
53	n	38	MET	CG-SD-CE	5.09	108.34	100.20
40	a	2613	U	N1-C2-N3	-5.07	111.86	114.90
17	D	397	A	N9-C4-C5	-5.07	103.77	105.80
7	6	22	DC	P-O3'-C3'	5.07	125.78	119.70

Continued on next page...

Continued from previous page...

Mol	Chain	Res	Type	Atoms	Z	Observed(°)	Ideal(°)
10	A	39	C	C2-N3-C4	5.07	122.43	119.90
17	D	280	C	C4-C5-C6	-5.04	114.88	117.40
17	D	1358	U	N3-C2-O2	5.04	125.73	122.20
17	D	1363	A	N1-C2-N3	-5.04	126.78	129.30
62	w	112	TYR	CG-CD2-CE2	5.04	125.33	121.30
40	a	130	C	C6-N1-C2	5.04	122.32	120.30
17	D	368	U	C2-N1-C1'	5.04	123.74	117.70
38	Y	5	GLN	CA-CB-CG	5.03	124.46	113.40
40	a	520	G	N3-C4-N9	-5.03	122.98	126.00
40	a	1141	U	C5-C6-N1	5.03	125.21	122.70
17	D	563	A	C5-C6-N1	5.02	120.21	117.70
24	K	71	MET	CB-CA-C	5.01	120.42	110.40
40	a	537	G	OP1-P-OP2	5.01	127.11	119.60
17	D	882	C	C6-N1-C2	5.01	122.30	120.30
17	D	1526	G	C8-N9-C1'	-5.00	120.50	127.00
20	G	113	ARG	NH1-CZ-NH2	-5.00	113.89	119.40

There are no chirality outliers.

All (26) planarity outliers are listed below:

Mol	Chain	Res	Type	Group
9	9	107	GLU	Peptide
9	9	79	PRO	Peptide
9	9	92	ALA	Peptide
13	AC	192	VAL	Peptide
13	AD	20	SER	Peptide
14	AE	1326	GLN	Peptide
14	AE	1344	LEU	Peptide
14	AE	313	GLY	Peptide
14	AE	416	ILE	Peptide
20	G	19	GLN	Sidechain
21	H	124	LEU	Peptide
21	H	171	ARG	Peptide
21	H	274	TYR	Peptide
21	H	81	GLU	Peptide
21	H	82	THR	Peptide
22	I	167	TRP	Mainchain
24	K	45	ARG	Mainchain
24	K	77	ASN	Peptide
28	O	12	ARG	Peptide
37	X	65	VAL	Peptide
38	Y	5	GLN	Peptide

Continued on next page...

Continued from previous page...

Mol	Chain	Res	Type	Group
53	n	176	PRO	Peptide
54	o	31	HIS	Peptide
58	s	74	TYR	Sidechain
60	u	35	HIS	Peptide
60	u	62	PRO	Peptide

5.2 Too-close contacts [i](#)

Due to software issues we are unable to calculate clashes - this section is therefore empty.

5.3 Torsion angles [i](#)

5.3.1 Protein backbone [i](#)

In the following table, the Percentiles column shows the percent Ramachandran outliers of the chain as a percentile score with respect to all PDB entries followed by that with respect to all EM entries.

The Analysed column shows the number of residues for which the backbone conformation was analysed, and the total number of residues.

Mol	Chain	Analysed	Favoured	Allowed	Outliers	Percentiles	
1	0	101/103 (98%)	97 (96%)	4 (4%)	0	100	100
2	1	108/110 (98%)	107 (99%)	1 (1%)	0	100	100
3	2	92/100 (92%)	87 (95%)	5 (5%)	0	100	100
4	3	101/104 (97%)	98 (97%)	3 (3%)	0	100	100
5	4	92/94 (98%)	89 (97%)	3 (3%)	0	100	100
9	9	146/165 (88%)	100 (68%)	43 (30%)	3 (2%)	7	37
11	AA	1312/1342 (98%)	1193 (91%)	118 (9%)	1 (0%)	51	83
12	AB	159/162 (98%)	107 (67%)	36 (23%)	16 (10%)	0	3
13	AC	217/329 (66%)	203 (94%)	12 (6%)	2 (1%)	17	56
13	AD	214/329 (65%)	198 (92%)	16 (8%)	0	100	100
14	AE	1331/1407 (95%)	1212 (91%)	113 (8%)	6 (0%)	29	67
15	AF	80/91 (88%)	77 (96%)	3 (4%)	0	100	100
16	C	64/75 (85%)	63 (98%)	1 (2%)	0	100	100
18	E	84/87 (97%)	83 (99%)	1 (1%)	0	100	100

Continued on next page...

Continued from previous page...

Mol	Chain	Analysed	Favoured	Allowed	Outliers	Percentiles	
19	F	68/71 (96%)	68 (100%)	0	0	100	100
20	G	223/241 (92%)	212 (95%)	10 (4%)	1 (0%)	34	69
21	H	255/557 (46%)	182 (71%)	66 (26%)	7 (3%)	5	30
22	I	206/233 (88%)	193 (94%)	13 (6%)	0	100	100
23	J	203/206 (98%)	201 (99%)	2 (1%)	0	100	100
24	K	154/167 (92%)	145 (94%)	8 (5%)	1 (1%)	25	64
25	L	102/135 (76%)	97 (95%)	4 (4%)	1 (1%)	15	54
26	M	149/179 (83%)	140 (94%)	8 (5%)	1 (1%)	22	61
27	N	127/130 (98%)	123 (97%)	4 (3%)	0	100	100
28	O	125/130 (96%)	116 (93%)	8 (6%)	1 (1%)	19	58
29	P	97/103 (94%)	89 (92%)	8 (8%)	0	100	100
30	Q	115/129 (89%)	107 (93%)	8 (7%)	0	100	100
31	R	117/124 (94%)	112 (96%)	5 (4%)	0	100	100
32	S	98/101 (97%)	97 (99%)	1 (1%)	0	100	100
33	T	86/89 (97%)	83 (96%)	3 (4%)	0	100	100
34	U	80/82 (98%)	76 (95%)	4 (5%)	0	100	100
35	V	78/84 (93%)	74 (95%)	4 (5%)	0	100	100
36	W	81/92 (88%)	80 (99%)	1 (1%)	0	100	100
37	X	114/118 (97%)	103 (90%)	9 (8%)	2 (2%)	8	41
38	Y	139/142 (98%)	101 (73%)	38 (27%)	0	100	100
39	Z	28/121 (23%)	22 (79%)	6 (21%)	0	100	100
41	b	74/85 (87%)	73 (99%)	1 (1%)	0	100	100
42	c	75/78 (96%)	72 (96%)	3 (4%)	0	100	100
44	e	60/63 (95%)	57 (95%)	3 (5%)	0	100	100
45	f	56/59 (95%)	52 (93%)	4 (7%)	0	100	100
46	g	64/70 (91%)	62 (97%)	2 (3%)	0	100	100
47	h	269/273 (98%)	255 (95%)	14 (5%)	0	100	100
48	i	54/57 (95%)	49 (91%)	5 (9%)	0	100	100
49	j	207/209 (99%)	198 (96%)	9 (4%)	0	100	100
50	k	50/55 (91%)	50 (100%)	0	0	100	100
51	l	199/201 (99%)	188 (94%)	11 (6%)	0	100	100

Continued on next page...

Continued from previous page...

Mol	Chain	Analysed	Favoured	Allowed	Outliers	Percentiles	
52	m	44/46 (96%)	43 (98%)	1 (2%)	0	100	100
53	n	175/179 (98%)	160 (91%)	14 (8%)	1 (1%)	25	64
54	o	62/65 (95%)	57 (92%)	4 (6%)	1 (2%)	9	43
55	p	173/177 (98%)	162 (94%)	11 (6%)	0	100	100
56	q	36/38 (95%)	35 (97%)	1 (3%)	0	100	100
57	r	147/149 (99%)	139 (95%)	8 (5%)	0	100	100
58	s	140/142 (99%)	133 (95%)	7 (5%)	0	100	100
59	t	121/123 (98%)	114 (94%)	7 (6%)	0	100	100
60	u	142/144 (99%)	134 (94%)	8 (6%)	0	100	100
61	v	134/136 (98%)	129 (96%)	5 (4%)	0	100	100
62	w	117/127 (92%)	112 (96%)	5 (4%)	0	100	100
63	x	114/117 (97%)	107 (94%)	7 (6%)	0	100	100
64	y	112/115 (97%)	105 (94%)	7 (6%)	0	100	100
65	z	115/118 (98%)	111 (96%)	4 (4%)	0	100	100
All	All	9486/10558 (90%)	8732 (92%)	710 (8%)	44 (0%)	32	67

All (44) Ramachandran outliers are listed below:

Mol	Chain	Res	Type
12	AB	52	PRO
12	AB	60	ASP
12	AB	87	ILE
12	AB	98	VAL
12	AB	109	THR
20	G	127	ASP
21	H	304	VAL
26	M	56	LYS
54	o	32	ILE
12	AB	39	VAL
12	AB	45	ALA
12	AB	79	VAL
12	AB	105	VAL
12	AB	106	ASP
14	AE	92	VAL
14	AE	175	GLU
21	H	171	ARG
21	H	305	HIS

Continued on next page...

Continued from previous page...

Mol	Chain	Res	Type
21	H	309	MET
12	AB	61	PRO
12	AB	146	ILE
24	K	78	ASN
25	L	96	VAL
28	O	13	LYS
53	n	177	PHE
12	AB	67	THR
12	AB	72	THR
13	AC	193	GLU
21	H	82	THR
14	AE	74	LYS
14	AE	286	ALA
21	H	143	ASP
37	X	6	GLY
37	X	66	GLU
9	9	79	PRO
9	9	88	HIS
12	AB	74	GLY
13	AC	192	VAL
14	AE	290	ILE
21	H	71	ALA
14	AE	292	VAL
9	9	129	LEU
11	AA	1317	PRO
12	AB	63	VAL

5.3.2 Protein sidechains [i](#)

In the following table, the Percentiles column shows the percent sidechain outliers of the chain as a percentile score with respect to all PDB entries followed by that with respect to all EM entries.

The Analysed column shows the number of residues for which the sidechain conformation was analysed, and the total number of residues.

Mol	Chain	Analysed	Rotameric	Outliers	Percentiles	
1	0	84/84 (100%)	84 (100%)	0	100	100
2	1	93/93 (100%)	93 (100%)	0	100	100
3	2	81/84 (96%)	80 (99%)	1 (1%)	71	88
4	3	84/85 (99%)	84 (100%)	0	100	100

Continued on next page...

Continued from previous page...

Mol	Chain	Analysed	Rotameric	Outliers	Percentiles	
5	4	78/78 (100%)	78 (100%)	0	100	100
9	9	112/123 (91%)	109 (97%)	3 (3%)	44	75
11	AA	1135/1157 (98%)	1133 (100%)	2 (0%)	93	98
12	AB	141/142 (99%)	71 (50%)	70 (50%)	0	0
13	AC	186/286 (65%)	186 (100%)	0	100	100
13	AD	185/286 (65%)	185 (100%)	0	100	100
14	AE	1122/1168 (96%)	1102 (98%)	20 (2%)	59	82
15	AF	70/75 (93%)	70 (100%)	0	100	100
16	C	57/65 (88%)	57 (100%)	0	100	100
18	E	65/66 (98%)	65 (100%)	0	100	100
19	F	60/61 (98%)	60 (100%)	0	100	100
20	G	187/199 (94%)	186 (100%)	1 (0%)	88	95
21	H	137/461 (30%)	137 (100%)	0	100	100
22	I	171/190 (90%)	170 (99%)	1 (1%)	86	94
23	J	172/173 (99%)	171 (99%)	1 (1%)	86	94
24	K	119/126 (94%)	119 (100%)	0	100	100
25	L	91/116 (78%)	91 (100%)	0	100	100
26	M	124/147 (84%)	124 (100%)	0	100	100
27	N	104/105 (99%)	104 (100%)	0	100	100
28	O	105/107 (98%)	104 (99%)	1 (1%)	76	90
29	P	86/90 (96%)	85 (99%)	1 (1%)	71	88
30	Q	90/99 (91%)	90 (100%)	0	100	100
31	R	101/104 (97%)	101 (100%)	0	100	100
32	S	83/84 (99%)	83 (100%)	0	100	100
33	T	76/77 (99%)	76 (100%)	0	100	100
34	U	65/65 (100%)	64 (98%)	1 (2%)	65	85
35	V	74/78 (95%)	73 (99%)	1 (1%)	67	86
36	W	72/79 (91%)	72 (100%)	0	100	100
37	X	94/96 (98%)	94 (100%)	0	100	100
38	Y	109/110 (99%)	108 (99%)	1 (1%)	78	91
39	Z	26/85 (31%)	26 (100%)	0	100	100

Continued on next page...

Continued from previous page...

Mol	Chain	Analysed	Rotameric	Outliers	Percentiles	
41	b	58/63 (92%)	58 (100%)	0	100	100
42	c	67/68 (98%)	67 (100%)	0	100	100
44	e	54/55 (98%)	54 (100%)	0	100	100
45	f	48/49 (98%)	48 (100%)	0	100	100
46	g	59/62 (95%)	59 (100%)	0	100	100
47	h	216/218 (99%)	216 (100%)	0	100	100
48	i	47/48 (98%)	47 (100%)	0	100	100
49	j	164/164 (100%)	164 (100%)	0	100	100
50	k	47/49 (96%)	47 (100%)	0	100	100
51	l	165/165 (100%)	164 (99%)	1 (1%)	86	94
52	m	38/38 (100%)	38 (100%)	0	100	100
53	n	148/150 (99%)	148 (100%)	0	100	100
54	o	51/52 (98%)	51 (100%)	0	100	100
55	p	136/138 (99%)	136 (100%)	0	100	100
56	q	34/34 (100%)	34 (100%)	0	100	100
57	r	114/114 (100%)	114 (100%)	0	100	100
58	s	116/116 (100%)	115 (99%)	1 (1%)	78	91
59	t	104/104 (100%)	103 (99%)	1 (1%)	76	90
60	u	103/103 (100%)	103 (100%)	0	100	100
61	v	109/109 (100%)	109 (100%)	0	100	100
62	w	99/103 (96%)	98 (99%)	1 (1%)	76	90
63	x	86/87 (99%)	86 (100%)	0	100	100
64	y	99/100 (99%)	97 (98%)	2 (2%)	55	80
65	z	89/90 (99%)	88 (99%)	1 (1%)	73	88
All	All	7890/8723 (90%)	7779 (99%)	111 (1%)	68	86

All (111) residues with a non-rotameric sidechain are listed below:

Mol	Chain	Res	Type
3	2	6	ARG
9	9	56	ARG
9	9	73	LYS
9	9	94	ARG
11	AA	477	GLU

Continued on next page...

Continued from previous page...

Mol	Chain	Res	Type
11	AA	914	LYS
12	AB	6	LEU
12	AB	7	LEU
12	AB	8	TYR
12	AB	16	ARG
12	AB	18	GLN
12	AB	19	GLU
12	AB	20	HIS
12	AB	21	LEU
12	AB	22	GLU
12	AB	23	ARG
12	AB	26	VAL
12	AB	34	THR
12	AB	37	LYS
12	AB	39	VAL
12	AB	40	ARG
12	AB	42	LYS
12	AB	43	ARG
12	AB	44	THR
12	AB	47	SER
12	AB	50	LEU
12	AB	59	PHE
12	AB	60	ASP
12	AB	63	VAL
12	AB	64	ILE
12	AB	66	THR
12	AB	67	THR
12	AB	68	THR
12	AB	69	ILE
12	AB	72	THR
12	AB	73	ARG
12	AB	75	VAL
12	AB	78	PHE
12	AB	79	VAL
12	AB	80	ARG
12	AB	81	PHE
12	AB	84	SER
12	AB	87	ILE
12	AB	99	TYR
12	AB	100	LYS
12	AB	102	LYS
12	AB	103	ASP

Continued on next page...

Continued from previous page...

Mol	Chain	Res	Type
12	AB	104	ILE
12	AB	114	ASP
12	AB	115	LYS
12	AB	116	VAL
12	AB	117	ILE
12	AB	118	ILE
12	AB	123	PHE
12	AB	126	PHE
12	AB	127	GLN
12	AB	129	ILE
12	AB	136	GLU
12	AB	138	ARG
12	AB	140	MET
12	AB	141	LEU
12	AB	142	LEU
12	AB	143	LEU
12	AB	144	ASN
12	AB	145	LEU
12	AB	146	ILE
12	AB	149	GLU
12	AB	150	ILE
12	AB	151	LYS
12	AB	153	SER
12	AB	154	VAL
12	AB	156	ASN
12	AB	159	PHE
12	AB	160	ARG
12	AB	161	LYS
12	AB	162	LEU
14	AE	69	GLU
14	AE	70	CYS
14	AE	71	LEU
14	AE	74	LYS
14	AE	76	LYS
14	AE	77	ARG
14	AE	78	LEU
14	AE	79	LYS
14	AE	81	ARG
14	AE	85	CYS
14	AE	87	LYS
14	AE	92	VAL
14	AE	93	THR

Continued on next page...

Continued from previous page...

Mol	Chain	Res	Type
14	AE	290	ILE
14	AE	291	ILE
14	AE	292	VAL
14	AE	431	ARG
14	AE	514	THR
14	AE	744	ARG
14	AE	1369	ARG
20	G	105	LYS
22	I	72	ARG
23	J	47	ARG
28	O	12	ARG
29	P	5	ARG
34	U	35	ARG
35	V	27	ARG
38	Y	44	LYS
51	l	57	LYS
58	s	86	GLN
59	t	108	ARG
62	w	73	ASN
64	y	6	LYS
64	y	38	LYS
65	z	22	LYS

Sometimes sidechains can be flipped to improve hydrogen bonding and reduce clashes. All (78) such sidechains are listed below:

Mol	Chain	Res	Type
1	0	6	GLN
2	1	7	HIS
3	2	15	HIS
9	9	9	GLN
11	AA	69	GLN
11	AA	150	HIS
11	AA	314	ASN
11	AA	387	ASN
11	AA	513	GLN
11	AA	554	HIS
11	AA	580	GLN
11	AA	604	HIS
11	AA	688	GLN
11	AA	1268	GLN
11	AA	1299	ASN
11	AA	1313	HIS

Continued on next page...

Continued from previous page...

Mol	Chain	Res	Type
12	AB	18	GLN
12	AB	20	HIS
12	AB	24	GLN
12	AB	70	ASN
12	AB	94	HIS
12	AB	127	GLN
12	AB	156	ASN
13	AC	147	GLN
13	AD	66	HIS
13	AD	84	ASN
13	AD	117	HIS
13	AD	227	GLN
14	AE	80	HIS
14	AE	157	GLN
14	AE	450	HIS
14	AE	777	HIS
14	AE	805	GLN
14	AE	1108	GLN
14	AE	1326	GLN
14	AE	1367	GLN
15	AF	31	GLN
16	C	54	GLN
18	E	13	GLN
18	E	61	GLN
19	F	9	ASN
20	G	18	HIS
20	G	39	HIS
20	G	109	GLN
22	I	3	GLN
22	I	6	HIS
22	I	32	ASN
22	I	190	HIS
23	J	131	ASN
23	J	198	HIS
24	K	70	ASN
25	L	3	HIS
25	L	68	GLN
26	M	68	ASN
28	O	5	GLN
33	T	80	GLN
34	U	26	ASN
38	Y	5	GLN

Continued on next page...

Continued from previous page...

Mol	Chain	Res	Type
44	e	25	GLN
44	e	31	GLN
45	f	20	HIS
47	h	53	HIS
49	j	173	GLN
51	l	92	HIS
52	m	29	GLN
53	n	5	HIS
54	o	24	HIS
56	q	13	ASN
58	s	132	HIS
61	v	45	GLN
61	v	97	GLN
62	w	18	GLN
63	x	19	GLN
63	x	38	GLN
64	y	10	GLN
64	y	77	HIS
65	z	37	GLN
65	z	72	ASN

5.3.3 RNA [i](#)

Mol	Chain	Analysed	Backbone Outliers	Pucker Outliers
10	A	75/76 (98%)	29 (38%)	8 (10%)
10	B	75/76 (98%)	29 (38%)	8 (10%)
17	D	1515/1542 (98%)	290 (19%)	21 (1%)
40	a	2859/2904 (98%)	508 (17%)	0
43	d	119/120 (99%)	15 (12%)	0
8	7	36/41 (87%)	26 (72%)	5 (13%)
All	All	4679/4759 (98%)	897 (19%)	42 (0%)

All (897) RNA backbone outliers are listed below:

Mol	Chain	Res	Type
8	7	3	G
8	7	4	U
8	7	5	U
8	7	7	U
8	7	8	U
8	7	9	U

Continued on next page...

Continued from previous page...

Mol	Chain	Res	Type
8	7	10	U
8	7	11	U
8	7	12	U
8	7	13	U
8	7	14	U
8	7	15	U
8	7	16	U
8	7	17	U
8	7	18	U
8	7	19	U
8	7	20	U
8	7	21	U
8	7	22	U
8	7	23	U
8	7	29	A
8	7	30	U
8	7	31	U
8	7	32	U
8	7	35	U
8	7	37	A
10	A	2	G
10	A	6	G
10	A	7	G
10	A	8	U
10	A	10	G
10	A	13	C
10	A	14	A
10	A	16	C
10	A	17	C
10	A	18	G
10	A	19	G
10	A	20	U
10	A	21	A
10	A	22	G
10	A	23	C
10	A	30	G
10	A	46	G
10	A	47	U
10	A	48	C
10	A	49	G
10	A	52	G
10	A	57	A

Continued on next page...

Continued from previous page...

Mol	Chain	Res	Type
10	A	58	A
10	A	59	A
10	A	61	C
10	A	66	C
10	A	69	C
10	A	71	C
10	A	73	A
10	B	2	G
10	B	6	G
10	B	7	G
10	B	8	U
10	B	10	G
10	B	13	C
10	B	14	A
10	B	16	C
10	B	17	C
10	B	18	G
10	B	19	G
10	B	20	U
10	B	21	A
10	B	22	G
10	B	23	C
10	B	30	G
10	B	46	G
10	B	47	U
10	B	48	C
10	B	49	G
10	B	52	G
10	B	57	A
10	B	58	A
10	B	59	A
10	B	61	C
10	B	66	C
10	B	69	C
10	B	71	C
10	B	73	A
17	D	4	U
17	D	5	U
17	D	9	G
17	D	22	G
17	D	29	U
17	D	32	A

Continued on next page...

Continued from previous page...

Mol	Chain	Res	Type
17	D	39	G
17	D	47	C
17	D	48	C
17	D	50	A
17	D	51	A
17	D	52	C
17	D	54	C
17	D	68	G
17	D	69	G
17	D	71	A
17	D	72	A
17	D	74	A
17	D	76	G
17	D	82	G
17	D	83	C
17	D	84	U
17	D	87	C
17	D	90	C
17	D	94	G
17	D	95	C
17	D	96	U
17	D	108	G
17	D	120	A
17	D	121	U
17	D	122	G
17	D	131	A
17	D	141	G
17	D	144	G
17	D	148	G
17	D	149	A
17	D	160	A
17	D	164	G
17	D	173	U
17	D	181	A
17	D	182	A
17	D	183	C
17	D	184	G
17	D	197	A
17	D	198	G
17	D	204	G
17	D	208	U
17	D	209	U

Continued on next page...

Continued from previous page...

Mol	Chain	Res	Type
17	D	210	C
17	D	211	G
17	D	212	G
17	D	216	U
17	D	226	G
17	D	245	U
17	D	247	G
17	D	251	G
17	D	253	A
17	D	258	G
17	D	262	A
17	D	266	G
17	D	267	C
17	D	271	C
17	D	279	A
17	D	289	G
17	D	299	G
17	D	306	A
17	D	321	A
17	D	328	C
17	D	329	A
17	D	332	G
17	D	347	G
17	D	352	C
17	D	353	A
17	D	354	G
17	D	355	C
17	D	367	U
17	D	372	C
17	D	373	A
17	D	376	G
17	D	382	A
17	D	384	G
17	D	392	C
17	D	397	A
17	D	398	U
17	D	406	G
17	D	411	A
17	D	412	A
17	D	413	G
17	D	414	A
17	D	421	U

Continued on next page...

Continued from previous page...

Mol	Chain	Res	Type
17	D	422	C
17	D	424	G
17	D	429	U
17	D	446	G
17	D	451	A
17	D	457	G
17	D	458	U
17	D	463	U
17	D	464	U
17	D	467	U
17	D	468	A
17	D	469	C
17	D	478	A
17	D	479	U
17	D	481	G
17	D	484	G
17	D	485	U
17	D	486	U
17	D	496	A
17	D	497	G
17	D	505	G
17	D	511	C
17	D	518	C
17	D	519	C
17	D	526	C
17	D	531	U
17	D	532	A
17	D	533	A
17	D	542	G
17	D	547	A
17	D	559	A
17	D	564	C
17	D	568	G
17	D	572	A
17	D	573	A
17	D	576	C
17	D	577	G
17	D	579	A
17	D	596	A
17	D	628	G
17	D	633	G
17	D	649	A

Continued on next page...

Continued from previous page...

Mol	Chain	Res	Type
17	D	650	G
17	D	653	U
17	D	665	A
17	D	695	A
17	D	700	G
17	D	723	U
17	D	724	G
17	D	731	G
17	D	734	G
17	D	735	C
17	D	747	A
17	D	748	G
17	D	755	G
17	D	760	G
17	D	777	A
17	D	793	U
17	D	794	A
17	D	815	A
17	D	817	C
17	D	828	U
17	D	829	G
17	D	832	G
17	D	841	C
17	D	843	U
17	D	844	G
17	D	845	A
17	D	846	G
17	D	849	G
17	D	874	G
17	D	887	G
17	D	902	G
17	D	914	A
17	D	916	U
17	D	926	G
17	D	934	C
17	D	935	A
17	D	960	U
17	D	963	G
17	D	965	U
17	D	969	A
17	D	972	C
17	D	975	A

Continued on next page...

Continued from previous page...

Mol	Chain	Res	Type
17	D	976	G
17	D	987	G
17	D	991	U
17	D	992	U
17	D	993	G
17	D	996	A
17	D	1004	A
17	D	1008	U
17	D	1009	U
17	D	1017	U
17	D	1018	G
17	D	1021	A
17	D	1024	G
17	D	1026	G
17	D	1028	C
17	D	1030	U
17	D	1031	C
17	D	1037	C
17	D	1043	G
17	D	1044	A
17	D	1046	A
17	D	1065	U
17	D	1085	U
17	D	1094	G
17	D	1095	U
17	D	1099	G
17	D	1101	A
17	D	1108	G
17	D	1124	G
17	D	1133	G
17	D	1135	U
17	D	1136	C
17	D	1137	C
17	D	1139	G
17	D	1140	C
17	D	1141	C
17	D	1142	G
17	D	1143	G
17	D	1145	A
17	D	1146	A
17	D	1151	A
17	D	1152	A

Continued on next page...

Continued from previous page...

Mol	Chain	Res	Type
17	D	1159	U
17	D	1167	A
17	D	1171	A
17	D	1174	G
17	D	1175	G
17	D	1176	A
17	D	1184	G
17	D	1193	G
17	D	1196	A
17	D	1197	A
17	D	1206	G
17	D	1211	U
17	D	1212	U
17	D	1213	A
17	D	1214	C
17	D	1215	G
17	D	1226	C
17	D	1227	A
17	D	1228	C
17	D	1238	A
17	D	1257	A
17	D	1260	G
17	D	1275	A
17	D	1276	G
17	D	1278	G
17	D	1279	G
17	D	1280	A
17	D	1285	A
17	D	1286	U
17	D	1287	A
17	D	1299	A
17	D	1300	G
17	D	1302	C
17	D	1305	G
17	D	1312	G
17	D	1317	C
17	D	1320	C
17	D	1323	G
17	D	1338	G
17	D	1340	A
17	D	1346	A
17	D	1347	G

Continued on next page...

Continued from previous page...

Mol	Chain	Res	Type
17	D	1353	G
17	D	1363	A
17	D	1370	G
17	D	1378	C
17	D	1379	G
17	D	1381	U
17	D	1391	U
17	D	1396	A
17	D	1397	C
17	D	1398	A
17	D	1404	C
17	D	1419	G
17	D	1429	A
17	D	1441	A
17	D	1446	A
17	D	1447	A
17	D	1448	C
17	D	1452	C
17	D	1453	G
17	D	1475	G
17	D	1487	G
17	D	1491	G
17	D	1492	A
17	D	1493	A
17	D	1494	G
17	D	1497	G
17	D	1503	A
17	D	1506	U
17	D	1517	G
17	D	1529	G
17	D	1530	G
17	D	1534	A
40	a	4	U
40	a	10	A
40	a	15	G
40	a	23	G
40	a	34	U
40	a	35	G
40	a	46	G
40	a	58	G
40	a	60	G
40	a	62	U

Continued on next page...

Continued from previous page...

Mol	Chain	Res	Type
40	a	63	A
40	a	71	A
40	a	74	A
40	a	75	G
40	a	83	A
40	a	84	A
40	a	85	G
40	a	96	C
40	a	101	A
40	a	102	U
40	a	103	A
40	a	110	G
40	a	118	A
40	a	119	A
40	a	120	U
40	a	131	A
40	a	136	G
40	a	139	U
40	a	140	C
40	a	141	G
40	a	163	C
40	a	165	A
40	a	181	A
40	a	196	A
40	a	215	G
40	a	216	A
40	a	222	A
40	a	225	C
40	a	248	G
40	a	249	C
40	a	261	G
40	a	264	C
40	a	265	A
40	a	266	G
40	a	267	C
40	a	271	G
40	a	272	A
40	a	275	C
40	a	276	U
40	a	278	A
40	a	285	G
40	a	291	G

Continued on next page...

Continued from previous page...

Mol	Chain	Res	Type
40	a	311	A
40	a	329	G
40	a	330	A
40	a	353	C
40	a	361	G
40	a	362	A
40	a	371	A
40	a	372	G
40	a	373	U
40	a	375	G
40	a	383	C
40	a	386	G
40	a	396	G
40	a	405	U
40	a	411	G
40	a	412	A
40	a	420	C
40	a	424	G
40	a	451	U
40	a	457	A
40	a	477	A
40	a	481	G
40	a	491	G
40	a	501	A
40	a	503	A
40	a	504	A
40	a	505	A
40	a	509	C
40	a	522	A
40	a	529	A
40	a	531	C
40	a	532	A
40	a	537	G
40	a	543	G
40	a	545	U
40	a	546	U
40	a	547	A
40	a	549	G
40	a	551	G
40	a	563	A
40	a	569	U
40	a	573	U

Continued on next page...

Continued from previous page...

Mol	Chain	Res	Type
40	a	575	A
40	a	588	U
40	a	603	A
40	a	609	A
40	a	613	A
40	a	614	A
40	a	615	U
40	a	616	A
40	a	627	A
40	a	637	A
40	a	645	C
40	a	647	G
40	a	654	A
40	a	668	A
40	a	686	U
40	a	710	U
40	a	717	C
40	a	730	A
40	a	738	G
40	a	757	G
40	a	764	A
40	a	765	C
40	a	775	G
40	a	776	G
40	a	782	A
40	a	784	G
40	a	785	G
40	a	800	A
40	a	805	G
40	a	812	C
40	a	819	A
40	a	827	U
40	a	828	U
40	a	845	A
40	a	846	U
40	a	858	G
40	a	859	G
40	a	869	G
40	a	878	A
40	a	881	G
40	a	884	U
40	a	885	C

Continued on next page...

Continued from previous page...

Mol	Chain	Res	Type
40	a	888	C
40	a	891	G
40	a	895	U
40	a	896	A
40	a	897	C
40	a	899	A
40	a	907	G
40	a	910	A
40	a	914	G
40	a	915	C
40	a	931	U
40	a	941	A
40	a	945	A
40	a	946	C
40	a	953	G
40	a	961	C
40	a	974	G
40	a	983	A
40	a	995	C
40	a	996	A
40	a	999	U
40	a	1005	C
40	a	1012	U
40	a	1013	C
40	a	1022	G
40	a	1023	U
40	a	1026	G
40	a	1033	U
40	a	1041	G
40	a	1045	C
40	a	1046	A
40	a	1047	G
40	a	1060	U
40	a	1061	U
40	a	1064	C
40	a	1065	U
40	a	1066	U
40	a	1067	A
40	a	1068	G
40	a	1070	A
40	a	1071	G
40	a	1073	A

Continued on next page...

Continued from previous page...

Mol	Chain	Res	Type
40	a	1074	G
40	a	1079	C
40	a	1080	A
40	a	1081	U
40	a	1082	U
40	a	1083	U
40	a	1084	A
40	a	1087	G
40	a	1088	A
40	a	1090	A
40	a	1095	A
40	a	1101	U
40	a	1107	G
40	a	1111	A
40	a	1112	G
40	a	1119	U
40	a	1122	G
40	a	1128	G
40	a	1132	U
40	a	1134	A
40	a	1135	C
40	a	1142	A
40	a	1169	A
40	a	1170	C
40	a	1173	U
40	a	1174	U
40	a	1175	A
40	a	1176	U
40	a	1177	G
40	a	1178	C
40	a	1179	G
40	a	1180	U
40	a	1186	G
40	a	1238	G
40	a	1248	G
40	a	1253	A
40	a	1256	G
40	a	1266	G
40	a	1271	G
40	a	1272	A
40	a	1273	U
40	a	1300	G

Continued on next page...

Continued from previous page...

Mol	Chain	Res	Type
40	a	1301	A
40	a	1321	A
40	a	1345	C
40	a	1352	U
40	a	1365	A
40	a	1368	G
40	a	1378	A
40	a	1379	U
40	a	1380	G
40	a	1383	A
40	a	1392	A
40	a	1395	A
40	a	1406	U
40	a	1408	G
40	a	1409	U
40	a	1414	C
40	a	1416	G
40	a	1417	C
40	a	1419	A
40	a	1420	A
40	a	1428	C
40	a	1452	G
40	a	1453	A
40	a	1460	U
40	a	1482	G
40	a	1490	A
40	a	1497	U
40	a	1503	A
40	a	1508	A
40	a	1509	A
40	a	1510	G
40	a	1515	A
40	a	1529	G
40	a	1534	U
40	a	1535	A
40	a	1536	C
40	a	1537	G
40	a	1554	U
40	a	1559	U
40	a	1566	A
40	a	1569	A
40	a	1578	U

Continued on next page...

Continued from previous page...

Mol	Chain	Res	Type
40	a	1580	A
40	a	1581	G
40	a	1583	A
40	a	1584	U
40	a	1585	C
40	a	1589	U
40	a	1590	A
40	a	1608	A
40	a	1610	A
40	a	1613	G
40	a	1647	U
40	a	1648	U
40	a	1649	G
40	a	1651	G
40	a	1665	A
40	a	1674	G
40	a	1677	A
40	a	1703	G
40	a	1714	U
40	a	1715	G
40	a	1729	U
40	a	1730	C
40	a	1732	C
40	a	1738	G
40	a	1750	G
40	a	1758	U
40	a	1764	C
40	a	1773	A
40	a	1791	A
40	a	1800	C
40	a	1808	A
40	a	1811	G
40	a	1816	C
40	a	1829	A
40	a	1833	C
40	a	1847	A
40	a	1848	A
40	a	1858	A
40	a	1859	U
40	a	1862	G
40	a	1864	U
40	a	1869	G

Continued on next page...

Continued from previous page...

Mol	Chain	Res	Type
40	a	1870	C
40	a	1872	A
40	a	1873	G
40	a	1906	G
40	a	1907	G
40	a	1913	A
40	a	1914	C
40	a	1919	A
40	a	1920	C
40	a	1922	G
40	a	1923	U
40	a	1924	C
40	a	1925	C
40	a	1926	U
40	a	1929	G
40	a	1930	G
40	a	1936	A
40	a	1938	A
40	a	1955	U
40	a	1965	C
40	a	1967	C
40	a	1970	A
40	a	1971	U
40	a	1972	G
40	a	1987	A
40	a	1991	U
40	a	1992	G
40	a	1993	U
40	a	1997	C
40	a	2002	G
40	a	2020	A
40	a	2022	U
40	a	2023	C
40	a	2027	G
40	a	2033	A
40	a	2043	C
40	a	2051	A
40	a	2052	A
40	a	2055	C
40	a	2056	G
40	a	2060	A
40	a	2061	G

Continued on next page...

Continued from previous page...

Mol	Chain	Res	Type
40	a	2062	A
40	a	2063	C
40	a	2097	A
40	a	2099	U
40	a	2100	G
40	a	2108	A
40	a	2110	G
40	a	2111	U
40	a	2113	U
40	a	2115	G
40	a	2116	G
40	a	2117	A
40	a	2118	U
40	a	2121	G
40	a	2122	U
40	a	2124	G
40	a	2125	G
40	a	2126	A
40	a	2127	G
40	a	2128	G
40	a	2131	U
40	a	2132	U
40	a	2133	G
40	a	2134	A
40	a	2139	U
40	a	2141	G
40	a	2146	C
40	a	2147	A
40	a	2154	A
40	a	2157	G
40	a	2158	A
40	a	2159	G
40	a	2162	G
40	a	2163	A
40	a	2164	C
40	a	2165	C
40	a	2169	A
40	a	2171	A
40	a	2172	U
40	a	2178	C
40	a	2182	U
40	a	2183	A

Continued on next page...

Continued from previous page...

Mol	Chain	Res	Type
40	a	2185	U
40	a	2189	U
40	a	2190	G
40	a	2193	G
40	a	2194	U
40	a	2198	A
40	a	2204	G
40	a	2211	A
40	a	2212	A
40	a	2225	A
40	a	2226	C
40	a	2229	U
40	a	2238	G
40	a	2239	G
40	a	2250	G
40	a	2268	A
40	a	2278	A
40	a	2283	C
40	a	2287	A
40	a	2288	A
40	a	2297	A
40	a	2305	U
40	a	2308	G
40	a	2309	A
40	a	2322	A
40	a	2325	G
40	a	2327	A
40	a	2333	A
40	a	2335	A
40	a	2339	C
40	a	2345	G
40	a	2347	C
40	a	2350	C
40	a	2361	G
40	a	2372	U
40	a	2376	A
40	a	2383	G
40	a	2385	C
40	a	2402	U
40	a	2403	C
40	a	2406	A
40	a	2423	U

Continued on next page...

Continued from previous page...

Mol	Chain	Res	Type
40	a	2424	C
40	a	2425	A
40	a	2426	A
40	a	2429	G
40	a	2430	A
40	a	2431	U
40	a	2434	A
40	a	2435	A
40	a	2441	U
40	a	2447	G
40	a	2448	A
40	a	2470	G
40	a	2474	U
40	a	2476	A
40	a	2478	A
40	a	2484	G
40	a	2491	U
40	a	2502	G
40	a	2506	U
40	a	2512	C
40	a	2513	A
40	a	2518	A
40	a	2520	C
40	a	2525	G
40	a	2529	G
40	a	2535	G
40	a	2554	U
40	a	2566	A
40	a	2567	G
40	a	2573	C
40	a	2574	G
40	a	2585	U
40	a	2586	U
40	a	2602	A
40	a	2603	G
40	a	2609	U
40	a	2610	C
40	a	2613	U
40	a	2629	U
40	a	2630	G
40	a	2663	G
40	a	2669	G

Continued on next page...

Continued from previous page...

Mol	Chain	Res	Type
40	a	2671	G
40	a	2689	U
40	a	2690	U
40	a	2714	G
40	a	2716	C
40	a	2726	A
40	a	2744	G
40	a	2748	A
40	a	2758	A
40	a	2765	A
40	a	2777	G
40	a	2778	A
40	a	2791	G
40	a	2793	C
40	a	2796	U
40	a	2797	U
40	a	2798	U
40	a	2799	A
40	a	2801	G
40	a	2818	U
40	a	2820	A
40	a	2823	A
40	a	2825	G
40	a	2835	A
40	a	2849	U
40	a	2859	G
40	a	2861	U
40	a	2867	G
40	a	2873	A
40	a	2874	C
40	a	2880	C
40	a	2883	A
40	a	2884	U
40	a	2885	G
40	a	2891	U
40	a	2902	C
43	d	2	G
43	d	13	G
43	d	16	G
43	d	17	C
43	d	35	C
43	d	45	A

Continued on next page...

Continued from previous page...

Mol	Chain	Res	Type
43	d	51	G
43	d	56	G
43	d	57	A
43	d	66	A
43	d	88	C
43	d	89	U
43	d	90	C
43	d	99	A
43	d	109	A

All (42) RNA pucker outliers are listed below:

Mol	Chain	Res	Type
8	7	4	U
8	7	7	U
8	7	10	U
8	7	18	U
8	7	28	G
10	A	6	G
10	A	7	G
10	A	9	G
10	A	12	G
10	A	21	A
10	A	22	G
10	A	57	A
10	A	60	U
10	B	6	G
10	B	7	G
10	B	9	G
10	B	12	G
10	B	21	A
10	B	22	G
10	B	57	A
10	B	60	U
17	D	121	U
17	D	181	A
17	D	183	C
17	D	197	A
17	D	209	U
17	D	428	G
17	D	496	A
17	D	517	G

Continued on next page...

Continued from previous page...

Mol	Chain	Res	Type
17	D	991	U
17	D	992	U
17	D	1109	C
17	D	1145	A
17	D	1196	A
17	D	1211	U
17	D	1212	U
17	D	1213	A
17	D	1214	C
17	D	1447	A
17	D	1491	G
17	D	1492	A
17	D	1493	A

5.4 Non-standard residues in protein, DNA, RNA chains [i](#)

There are no non-standard protein/DNA/RNA residues in this entry.

5.5 Carbohydrates [i](#)

There are no monosaccharides in this entry.

5.6 Ligand geometry [i](#)

Of 3 ligands modelled in this entry, 3 are monoatomic - leaving 0 for Mogul analysis.

There are no bond length outliers.

There are no bond angle outliers.

There are no chirality outliers.

There are no torsion outliers.

There are no ring outliers.

No monomer is involved in short contacts.

5.7 Other polymers [i](#)

There are no such residues in this entry.

5.8 Polymer linkage issues

There are no chain breaks in this entry.

6 Map visualisation [i](#)

This section contains visualisations of the EMDB entry EMD-42473. These allow visual inspection of the internal detail of the map and identification of artifacts.

Images derived from a raw map, generated by summing the deposited half-maps, are presented below the corresponding image components of the primary map to allow further visual inspection and comparison with those of the primary map.

6.1 Orthogonal projections [i](#)

6.1.1 Primary map

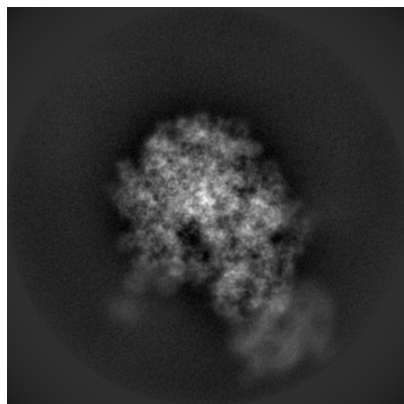

X

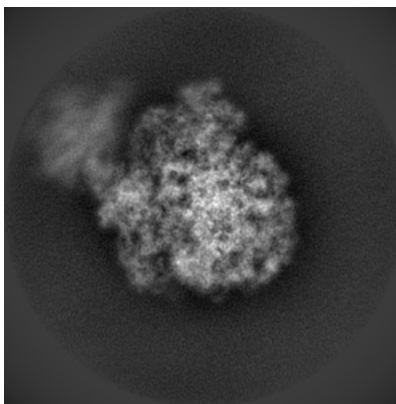

Y

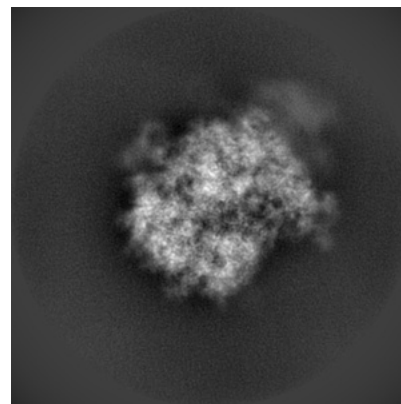

Z

6.1.2 Raw map

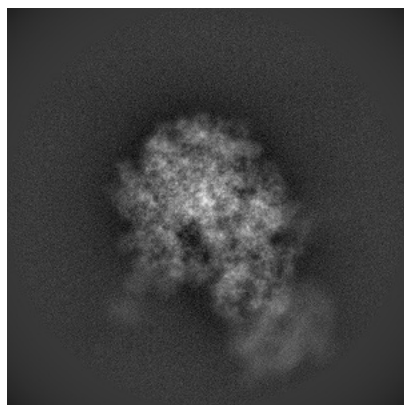

X

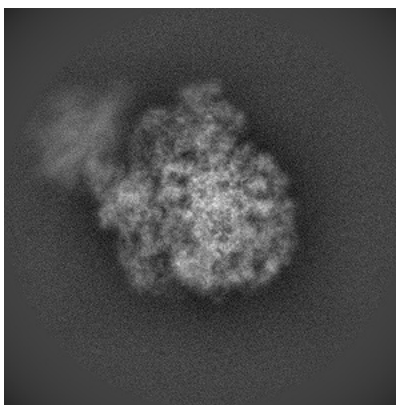

Y

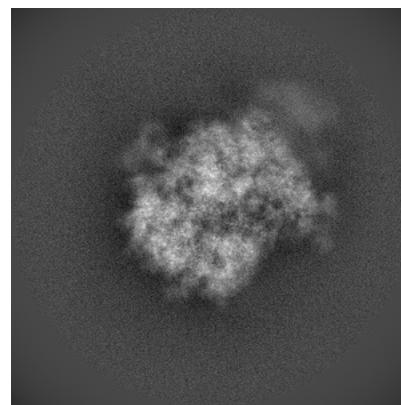

Z

The images above show the map projected in three orthogonal directions.

6.2 Central slices [i](#)

6.2.1 Primary map

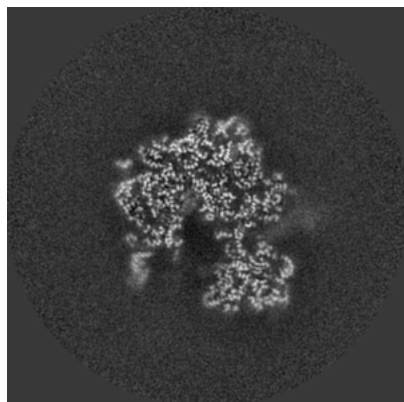

X Index: 288

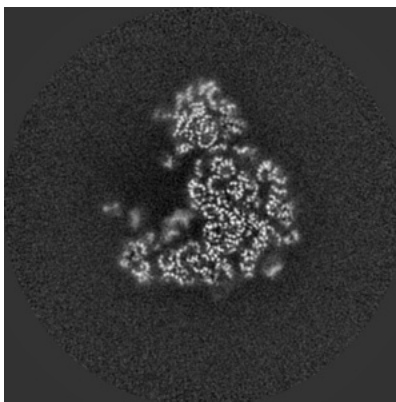

Y Index: 288

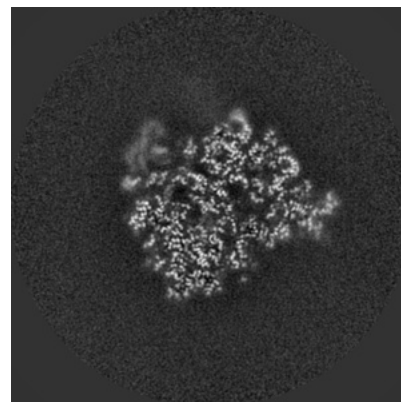

Z Index: 288

6.2.2 Raw map

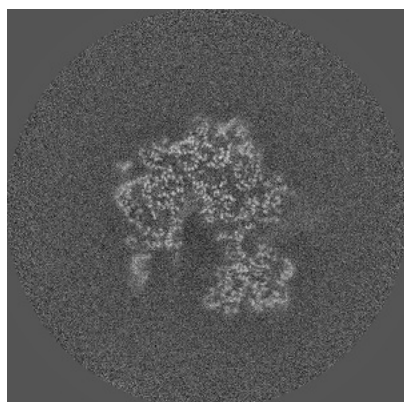

X Index: 288

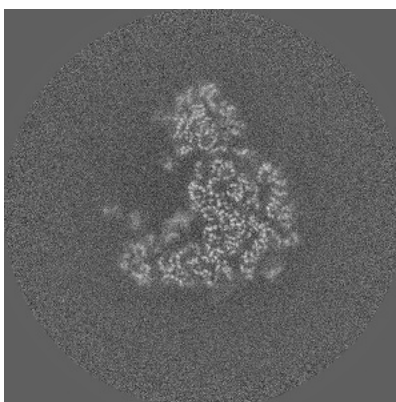

Y Index: 288

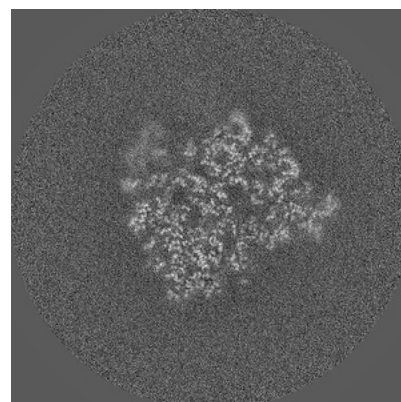

Z Index: 288

The images above show central slices of the map in three orthogonal directions.

6.3 Largest variance slices [i](#)

6.3.1 Primary map

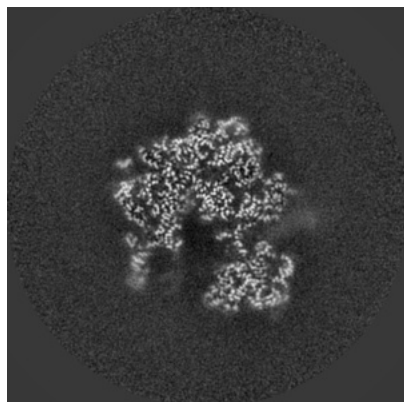

X Index: 290

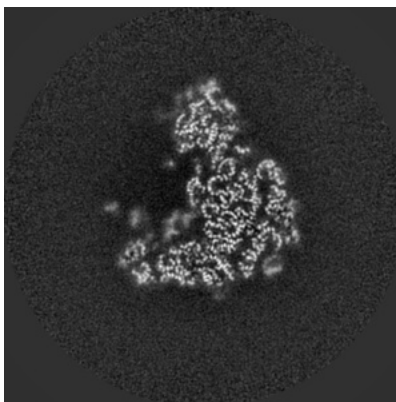

Y Index: 285

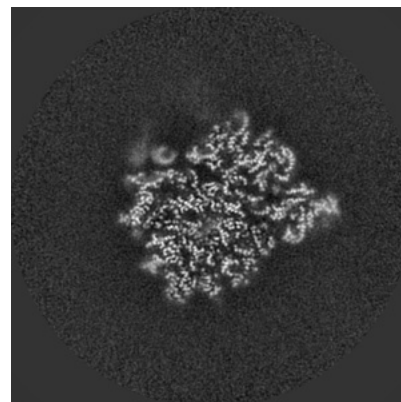

Z Index: 296

6.3.2 Raw map

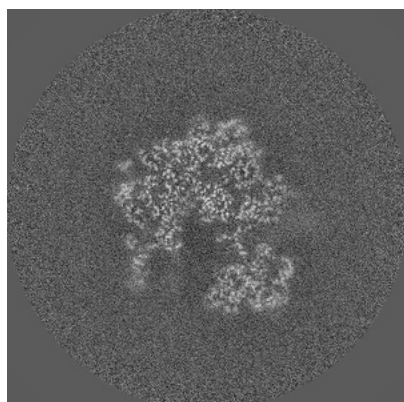

X Index: 290

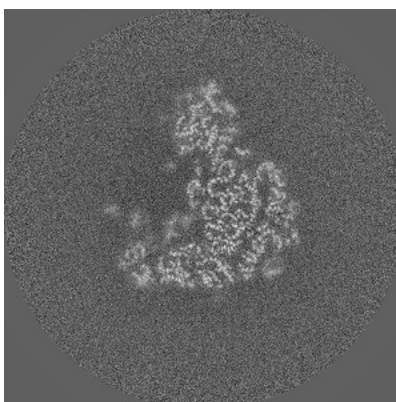

Y Index: 285

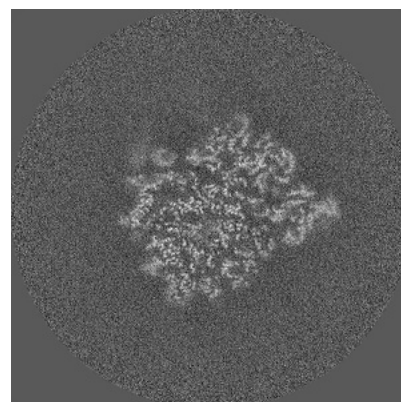

Z Index: 296

The images above show the largest variance slices of the map in three orthogonal directions.

6.4 Orthogonal standard-deviation projections (False-color) [i](#)

6.4.1 Primary map

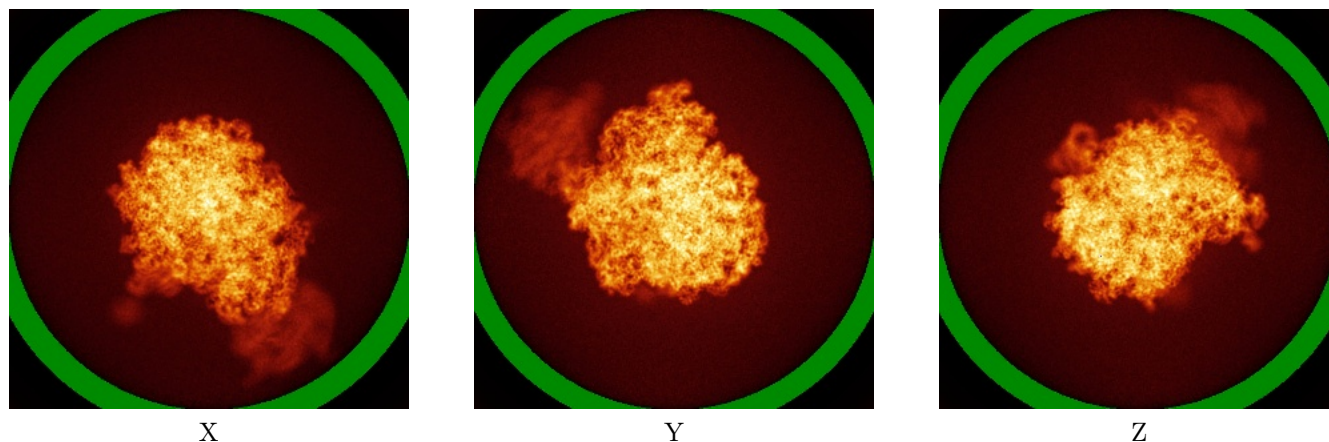

6.4.2 Raw map

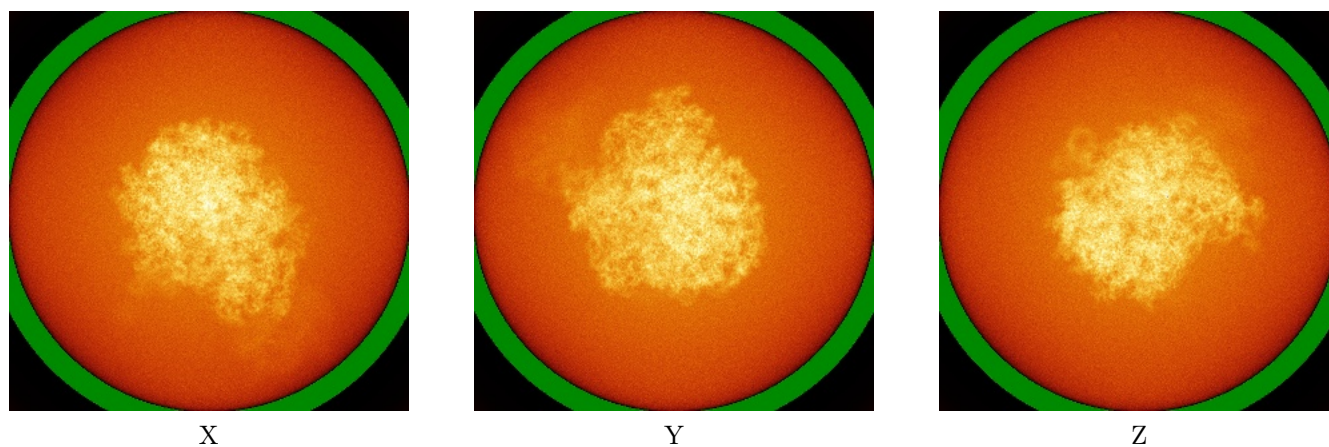

The images above show the map standard deviation projections with false color in three orthogonal directions. Minimum values are shown in green, max in blue, and dark to light orange shades represent small to large values respectively.

6.5 Orthogonal surface views [i](#)

6.5.1 Primary map

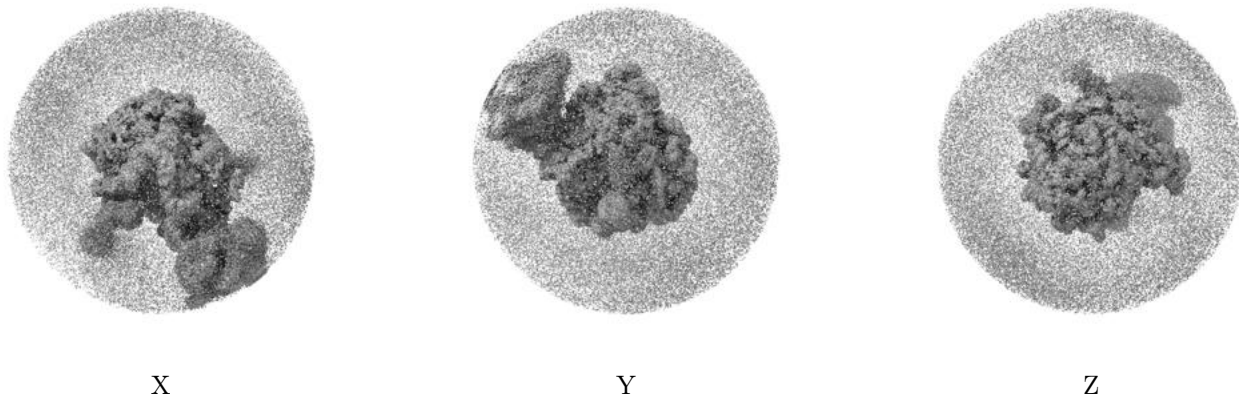

The images above show the 3D surface view of the map at the recommended contour level 0.002. These images, in conjunction with the slice images, may facilitate assessment of whether an appropriate contour level has been provided.

6.5.2 Raw map

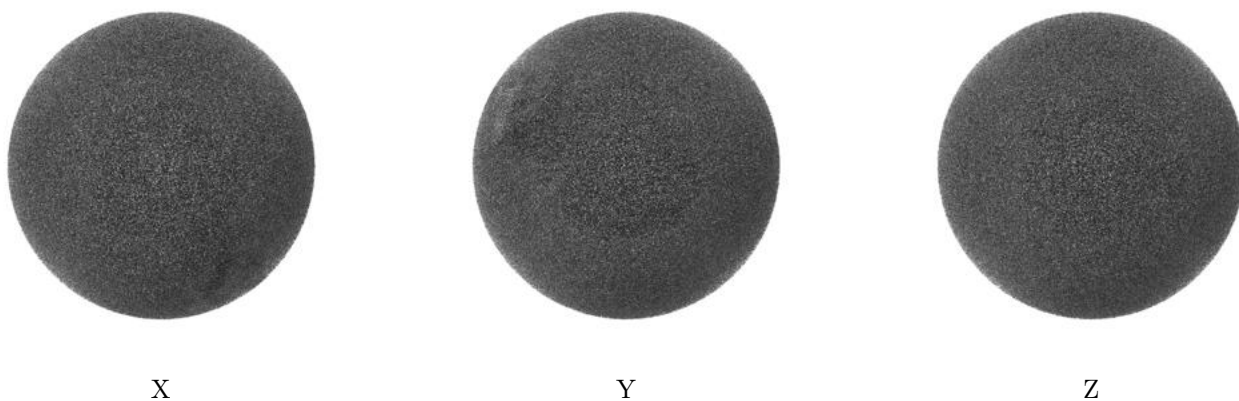

These images show the 3D surface of the raw map. The raw map's contour level was selected so that its surface encloses the same volume as the primary map does at its recommended contour level.

6.6 Mask visualisation [i](#)

This section was not generated. No masks/segmentation were deposited.

7 Map analysis [i](#)

This section contains the results of statistical analysis of the map.

7.1 Map-value distribution [i](#)

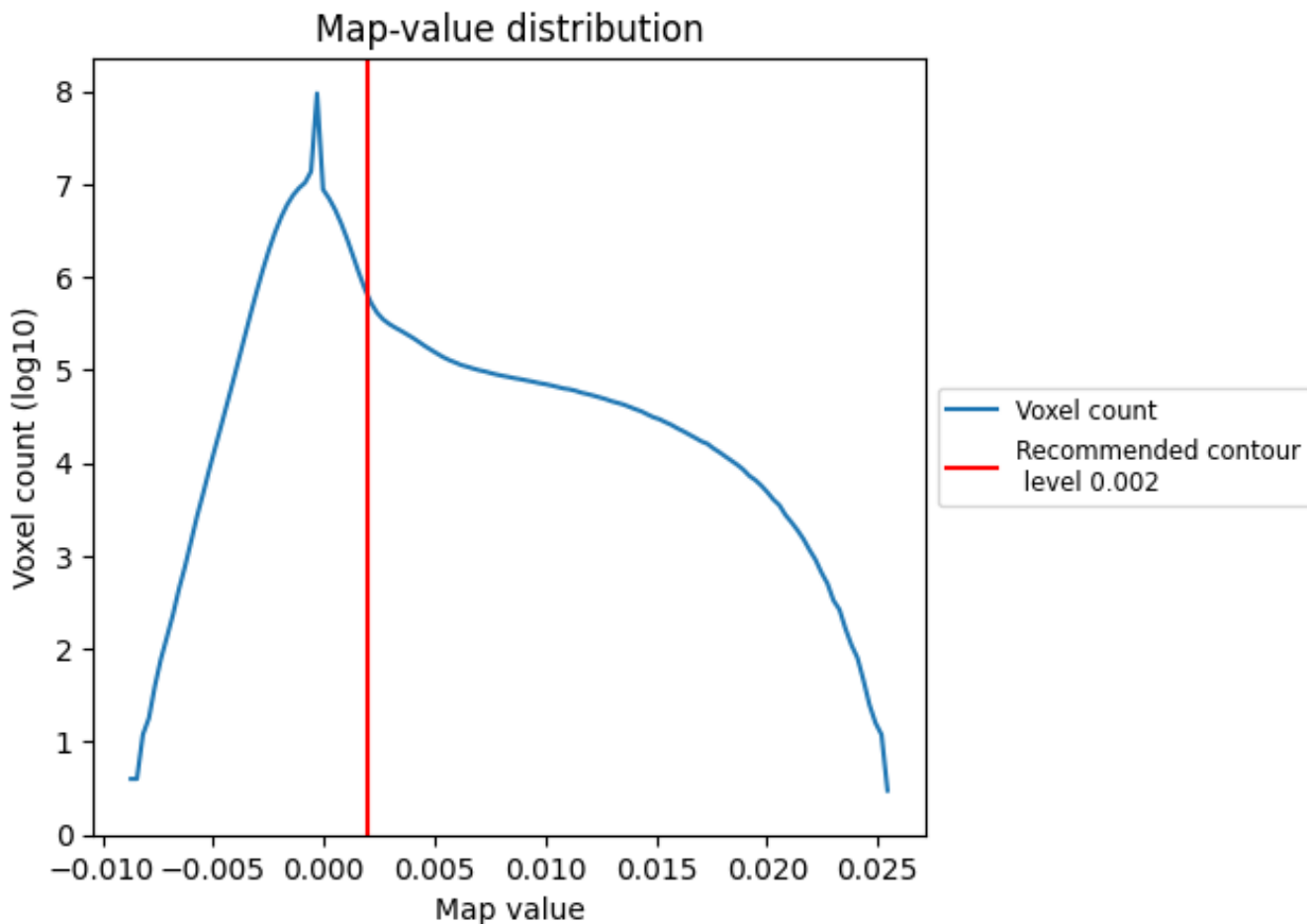

The map-value distribution is plotted in 128 intervals along the x-axis. The y-axis is logarithmic. A spike in this graph at zero usually indicates that the volume has been masked.

7.2 Volume estimate [\(i\)](#)

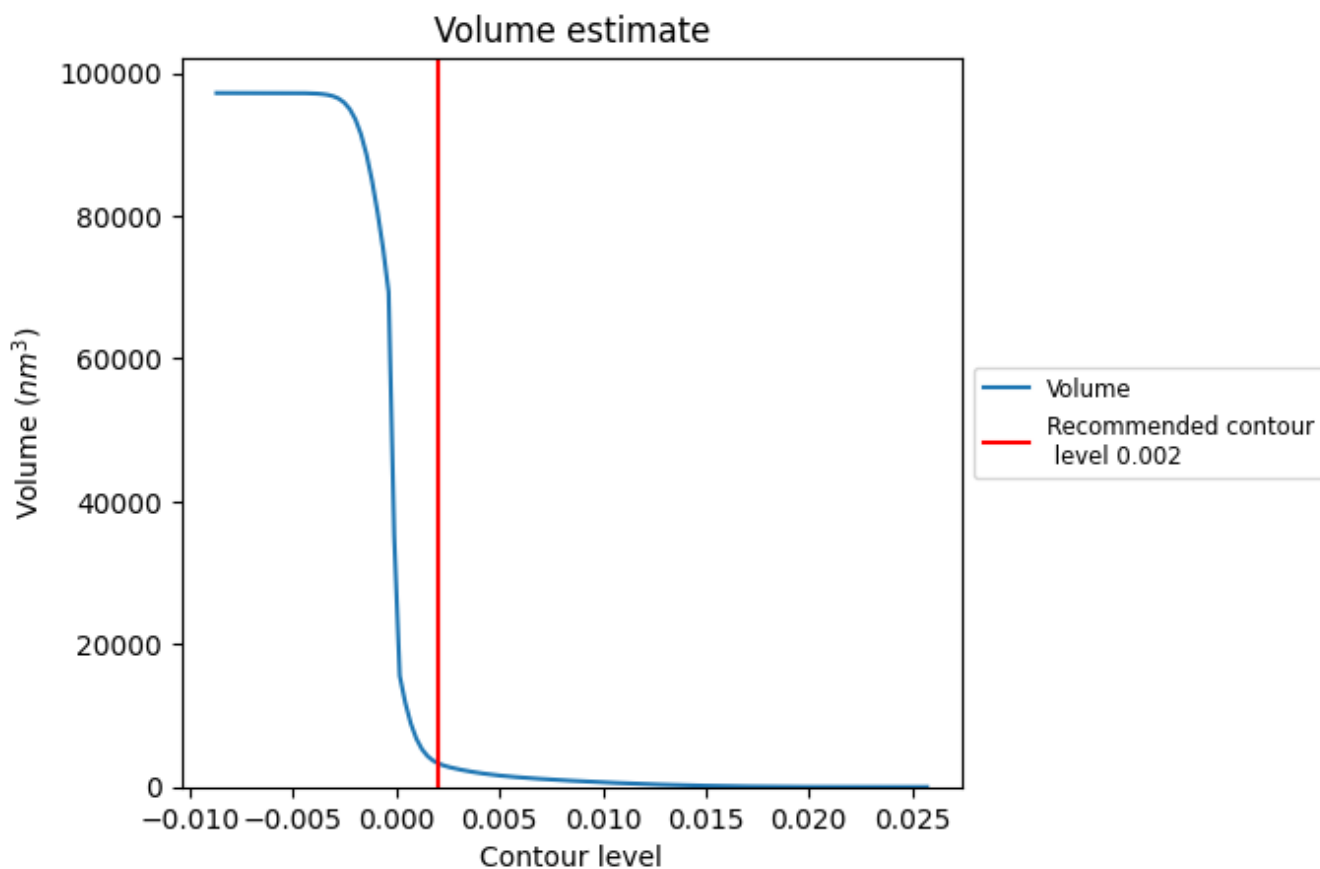

The volume at the recommended contour level is 3357 nm^3 ; this corresponds to an approximate mass of 3032 kDa.

The volume estimate graph shows how the enclosed volume varies with the contour level. The recommended contour level is shown as a vertical line and the intersection between the line and the curve gives the volume of the enclosed surface at the given level.

7.3 Rotationally averaged power spectrum [i](#)

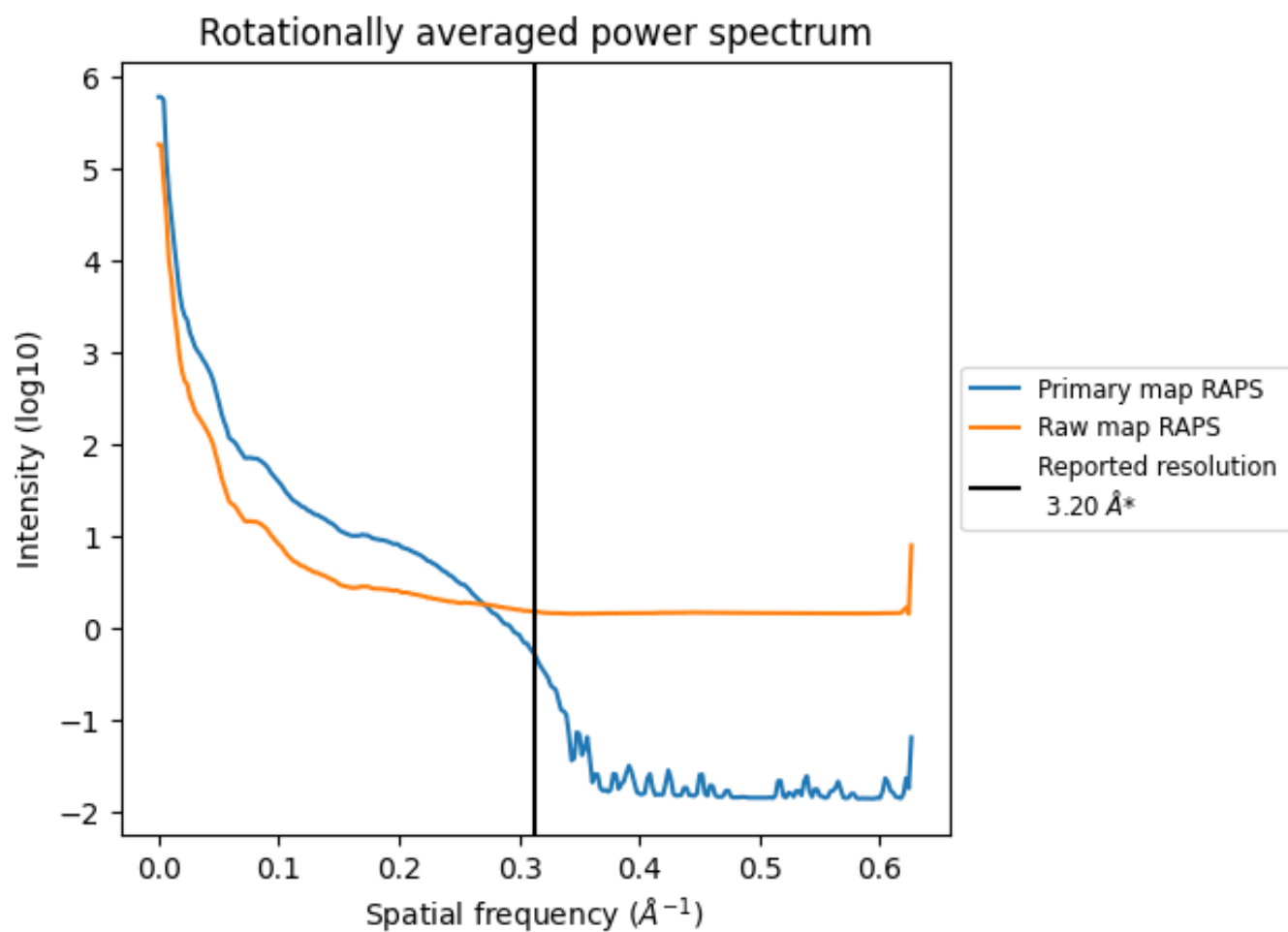

*Reported resolution corresponds to spatial frequency of 0.312 Å⁻¹

8 Fourier-Shell correlation [i](#)

Fourier-Shell Correlation (FSC) is the most commonly used method to estimate the resolution of single-particle and subtomogram-averaged maps. The shape of the curve depends on the imposed symmetry, mask and whether or not the two 3D reconstructions used were processed from a common reference. The reported resolution is shown as a black line. A curve is displayed for the half-bit criterion in addition to lines showing the 0.143 gold standard cut-off and 0.5 cut-off.

8.1 FSC [i](#)

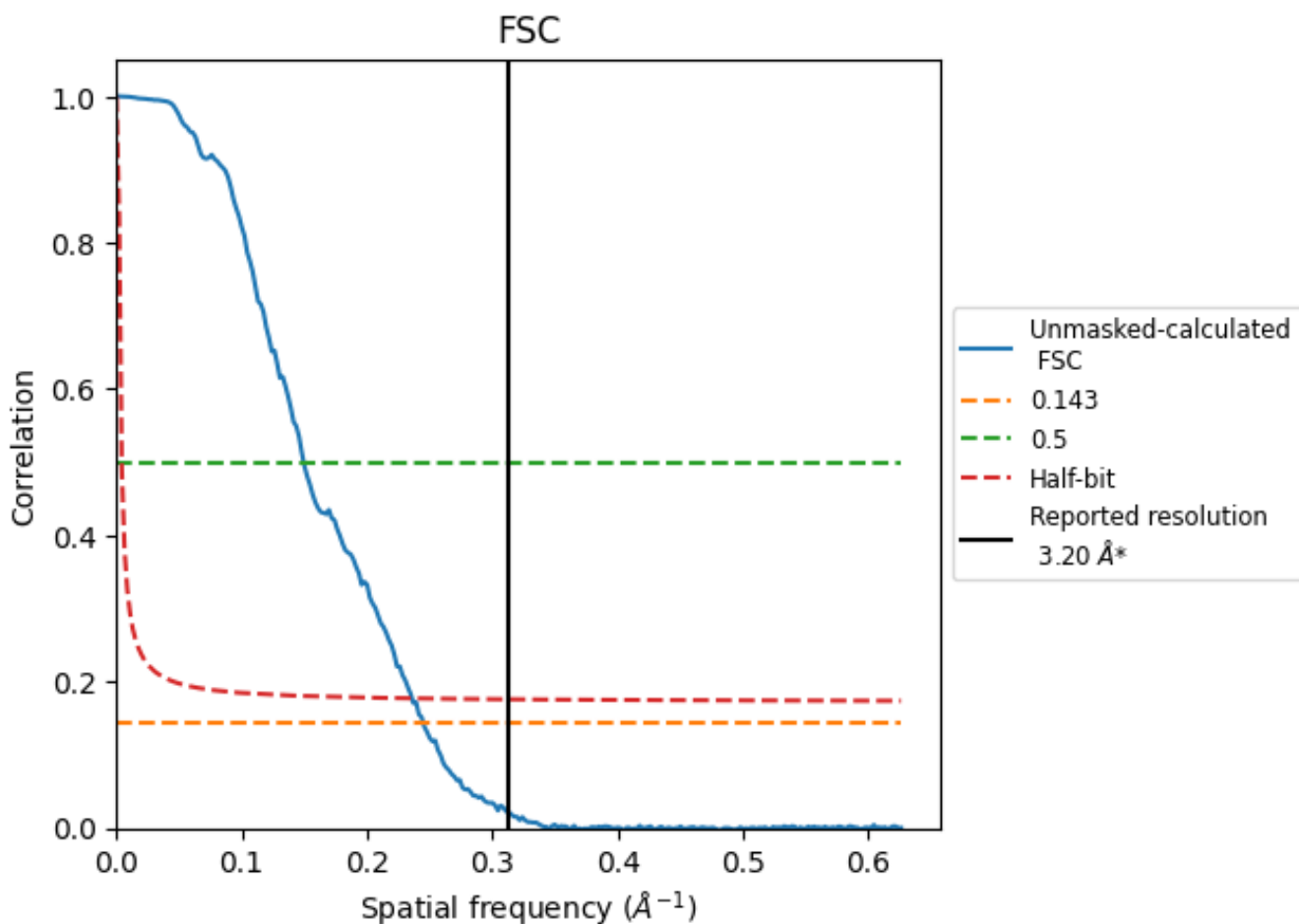

*Reported resolution corresponds to spatial frequency of 0.312 Å⁻¹

8.2 Resolution estimates [i](#)

Resolution estimate (Å)	Estimation criterion (FSC cut-off)		
	0.143	0.5	Half-bit
Reported by author	3.20	-	-
Author-provided FSC curve	-	-	-
Unmasked-calculated*	4.08	6.69	4.24

*Resolution estimate based on FSC curve calculated by comparison of deposited half-maps. The value from deposited half-maps intersecting FSC 0.143 CUT-OFF 4.08 differs from the reported value 3.2 by more than 10 %

9 Map-model fit [i](#)

This section contains information regarding the fit between EMDB map EMD-42473 and PDB model 8UQL. Per-residue inclusion information can be found in section 3 on page 16.

9.1 Map-model overlay [i](#)

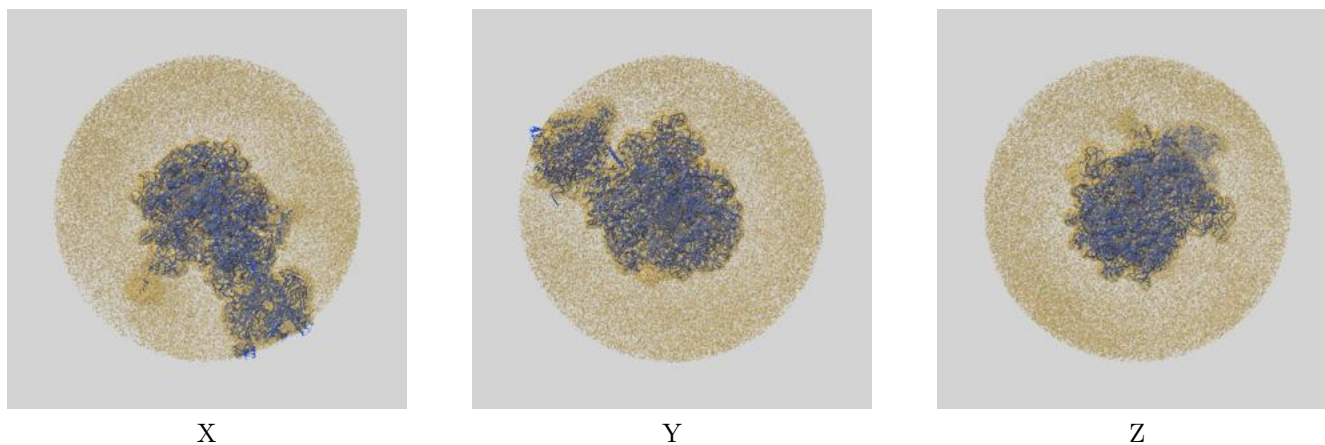

The images above show the 3D surface view of the map at the recommended contour level 0.002 at 50% transparency in yellow overlaid with a ribbon representation of the model coloured in blue. These images allow for the visual assessment of the quality of fit between the atomic model and the map.

9.2 Q-score mapped to coordinate model [i](#)

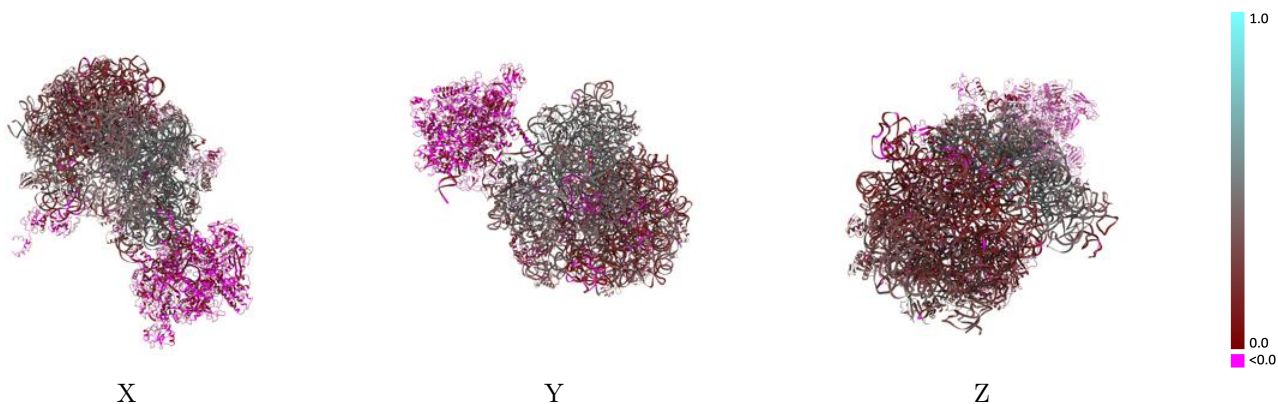

The images above show the model with each residue coloured according to its Q-score. This shows their resolvability in the map with higher Q-score values reflecting better resolvability. Please note: Q-score is calculating the resolvability of atoms, and thus high values are only expected at resolutions at which atoms can be resolved. Low Q-score values may therefore be expected for many entries.

9.3 Atom inclusion mapped to coordinate model [i](#)

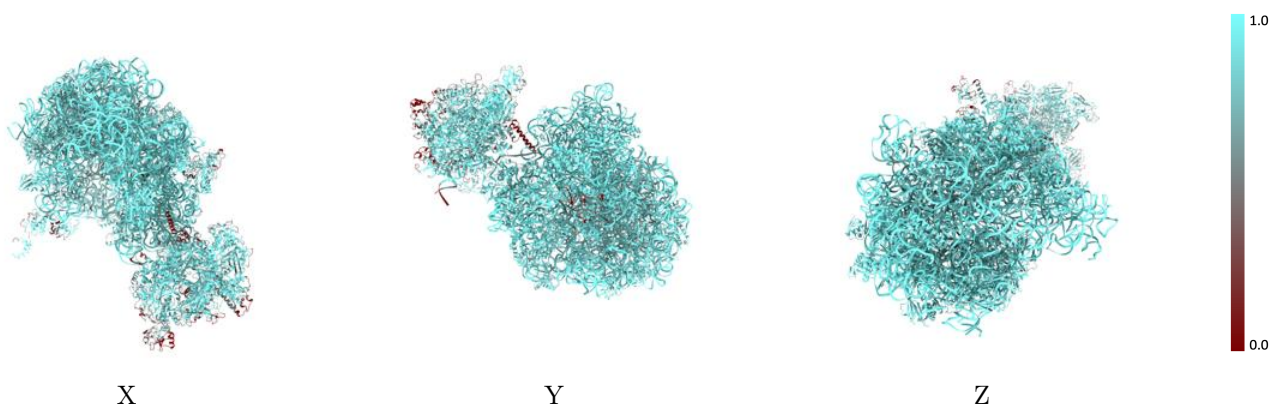

The images above show the model with each residue coloured according to its atom inclusion. This shows to what extent they are inside the map at the recommended contour level (0.002).



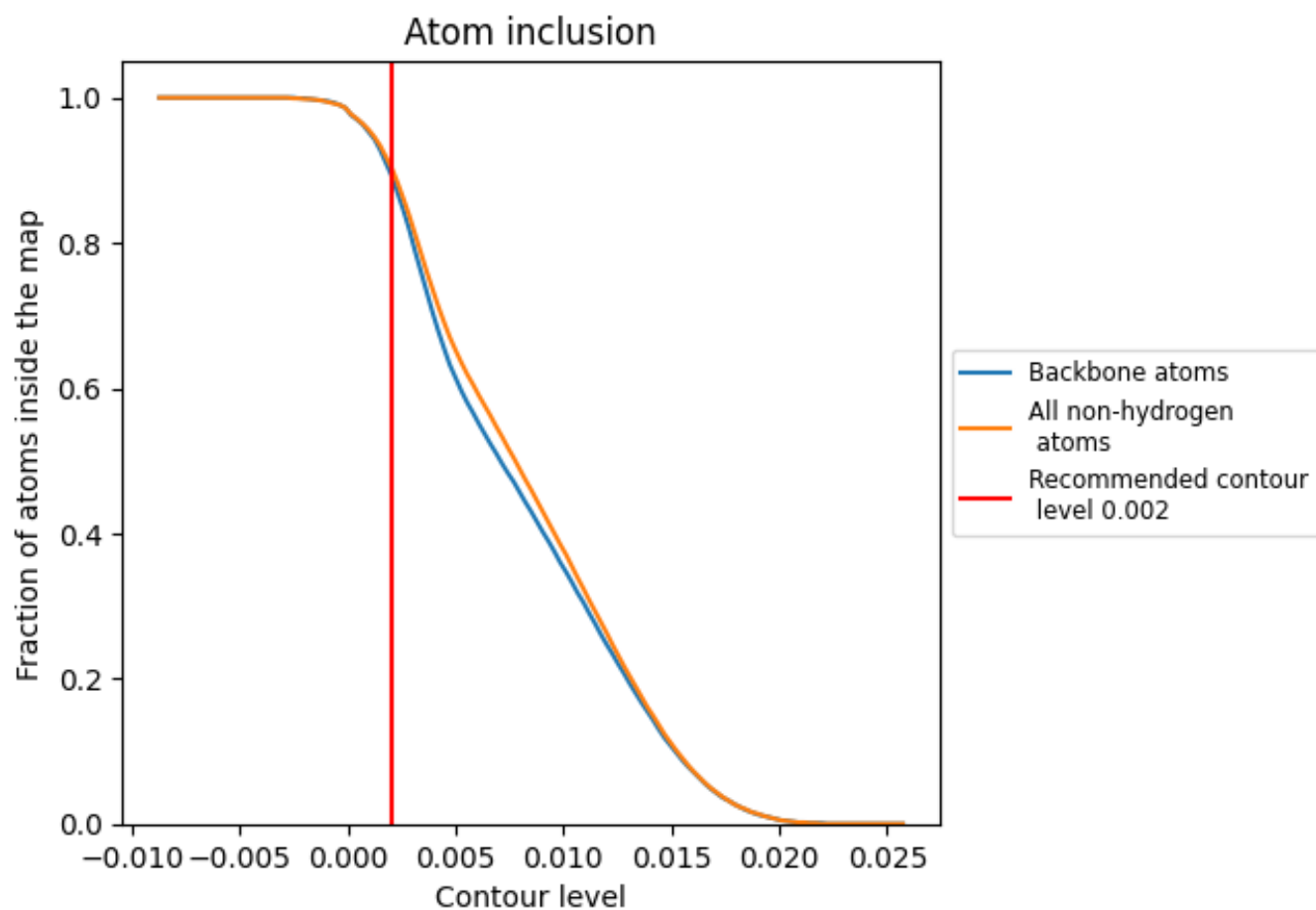



































































9.4 Atom inclusion [i](#)



At the recommended contour level, 90% of all backbone atoms, 91% of all non-hydrogen atoms, are inside the map.

9.5 Map-model fit summary



































































The table lists the average atom inclusion at the recommended contour level (0.002) and Q-score for the entire model and for each chain.

Chain	Atom inclusion	Q-score
All	 0.9060	 0.2520
0	 0.9270	 0.3450
1	 0.8620	 0.2530
2	 0.8740	 0.1910
3	 0.9320	 0.2560
4	 0.9530	 0.3450
5	 0.7740	 0.0840
6	 0.7780	 0.0820
7	 0.7420	 0.0560
9	 0.8640	 0.0440
A	 0.9620	 0.1960
AA	 0.7800	 0.0280
AB	 0.8900	 0.0950
AC	 0.8160	 0.0130
AD	 0.7720	 0.0320
AE	 0.8170	 0.0610
AF	 0.2570	 0.0360
B	 0.8070	 0.1170
C	 0.9540	 0.3960
D	 0.9950	 0.4430
E	 0.9630	 0.3750
F	 0.9110	 0.3380
G	 0.9530	 0.3760
H	 0.5670	 0.0380
I	 0.9400	 0.4160
J	 0.9640	 0.4040
K	 0.9490	 0.4450
L	 0.9490	 0.3490
M	 0.9340	 0.3530
N	 0.9650	 0.4390
O	 0.9750	 0.3940
P	 0.9350	 0.3580
Q	 0.9510	 0.3980
R	 0.9540	 0.4600
S	 0.9560	 0.3870



Continued on next page...

Continued from previous page...

Chain	Atom inclusion	Q-score
T	 0.9670	 0.3920
U	 0.9680	 0.4170
V	 0.9430	 0.4010
W	 0.8590	 0.1450
X	 0.8910	 0.1560
Y	 0.7140	 0.0510
Z	 0.8550	 -0.0160
a	 0.9550	 0.2310
b	 0.8940	 0.3040
c	 0.8370	 0.1670
d	 0.9920	 0.3040
e	 0.9200	 0.2190
f	 0.9290	 0.3320
g	 0.9220	 0.1420
h	 0.7910	 0.1260
i	 0.8810	 0.2110
j	 0.8760	 0.2230
k	 0.8830	 0.1770
l	 0.8700	 0.2490
m	 0.7830	 0.1730
n	 0.9120	 0.1740
o	 0.8290	 0.2540
p	 0.9500	 0.2990
q	 0.8970	 0.3200
r	 0.8100	 0.1190
s	 0.9230	 0.3470
t	 0.7970	 0.1690
u	 0.8790	 0.2510
v	 0.8950	 0.2770
w	 0.8810	 0.2030
x	 0.9460	 0.2400
y	 0.8670	 0.1740
z	 0.8920	 0.3060