



# wwPDB X-ray Structure Validation Summary Report ⓘ

Jan 4, 2024 – 06:52 pm GMT

PDB ID : 4V8P  
Title : T.thermophila 60S ribosomal subunit in complex with initiation factor 6.  
Authors : Klinge, S.; Voigts-Hoffmann, F.; Leibundgut, M.; Arpagaus, S.; Ban, N.  
Deposited on : 2011-09-14  
Resolution : 3.52 Å(reported)

This is a wwPDB X-ray Structure Validation Summary Report for a publicly released PDB entry.

We welcome your comments at [validation@mail.wwpdb.org](mailto:validation@mail.wwpdb.org)

A user guide is available at

<https://www.wwpdb.org/validation/2017/XrayValidationReportHelp>

with specific help available everywhere you see the ⓘ symbol.

The types of validation reports are described at

<http://www.wwpdb.org/validation/2017/FAQs#types>.

---

The following versions of software and data (see [references ⓘ](#)) were used in the production of this report:

MolProbity : 4.02b-467  
Xtriage (Phenix) : 1.13  
EDS : 2.36  
Percentile statistics : 20191225.v01 (using entries in the PDB archive December 25th 2019)  
Refmac : 5.8.0158  
CCP4 : 7.0.044 (Gargrove)  
Ideal geometry (proteins) : Engh & Huber (2001)  
Ideal geometry (DNA, RNA) : Parkinson et al. (1996)  
Validation Pipeline (wwPDB-VP) : 2.36

# 1 Overall quality at a glance i

The following experimental techniques were used to determine the structure:

*X-RAY DIFFRACTION*

The reported resolution of this entry is 3.52 Å.

Percentile scores (ranging between 0-100) for global validation metrics of the entry are shown in the following graphic. The table shows the number of entries on which the scores are based.

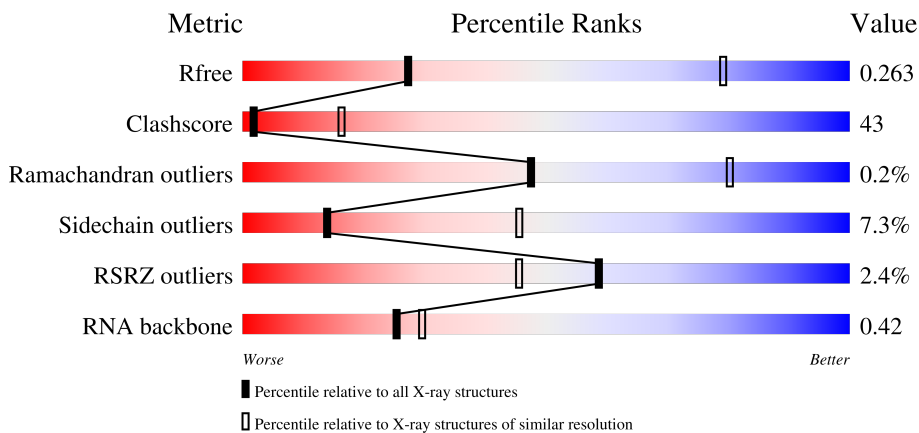

Metric	Whole archive (#Entries)	Similar resolution (#Entries, resolution range(Å))
$R_{free}$	130704	1161 (3.60-3.44)
Clashscore	141614	1244 (3.60-3.44)
Ramachandran outliers	138981	1206 (3.60-3.44)
Sidechain outliers	138945	1207 (3.60-3.44)
RSRZ outliers	127900	1080 (3.60-3.44)
RNA backbone	3102	1003 (4.02-3.00)

The table below summarises the geometric issues observed across the polymeric chains and their fit to the electron density. The red, orange, yellow and green segments of the lower bar indicate the fraction of residues that contain outliers for  $\geq 3$ , 2, 1 and 0 types of geometric quality criteria respectively. A grey segment represents the fraction of residues that are not modelled. The numeric value for each fraction is indicated below the corresponding segment, with a dot representing fractions  $\leq 5\%$ . The upper red bar (where present) indicates the fraction of residues that have poor fit to the electron density. The numeric value is given above the bar.

Mol	Chain	Length	Quality of chain
1	A1	3354	<div style="display: flex; align-items: center;"> <div style="width: 3%; height: 10px; background-color: red; margin-right: 5px;"></div> <div style="width: 18%; height: 10px; background-color: green; margin-right: 5px;"></div> <div style="width: 44%; height: 10px; background-color: yellow; margin-right: 5px;"></div> <div style="width: 29%; height: 10px; background-color: orange; margin-right: 5px;"></div> <div style="width: 7%; height: 10px; background-color: red; margin-right: 5px;"></div> <div style="width: 1%; height: 10px; background-color: grey;"></div> </div> <p style="font-size: small; margin-top: 5px;">3% 18% 44% 29% 7%</p>
1	D1	3354	<div style="display: flex; align-items: center;"> <div style="width: 0%; height: 10px; background-color: red; margin-right: 5px;"></div> <div style="width: 18%; height: 10px; background-color: green; margin-right: 5px;"></div> <div style="width: 44%; height: 10px; background-color: yellow; margin-right: 5px;"></div> <div style="width: 28%; height: 10px; background-color: orange; margin-right: 5px;"></div> <div style="width: 7%; height: 10px; background-color: red; margin-right: 5px;"></div> <div style="width: 1%; height: 10px; background-color: grey;"></div> </div> <p style="font-size: small; margin-top: 5px;">% 18% 44% 28% 7%</p>
1	F1	3354	<div style="display: flex; align-items: center;"> <div style="width: 2%; height: 10px; background-color: red; margin-right: 5px;"></div> <div style="width: 18%; height: 10px; background-color: green; margin-right: 5px;"></div> <div style="width: 44%; height: 10px; background-color: yellow; margin-right: 5px;"></div> <div style="width: 28%; height: 10px; background-color: orange; margin-right: 5px;"></div> <div style="width: 7%; height: 10px; background-color: red; margin-right: 5px;"></div> <div style="width: 1%; height: 10px; background-color: grey;"></div> </div> <p style="font-size: small; margin-top: 5px;">2% 18% 44% 28% 7%</p>
1	H1	3354	<div style="display: flex; align-items: center;"> <div style="width: 4%; height: 10px; background-color: red; margin-right: 5px;"></div> <div style="width: 17%; height: 10px; background-color: green; margin-right: 5px;"></div> <div style="width: 43%; height: 10px; background-color: yellow; margin-right: 5px;"></div> <div style="width: 29%; height: 10px; background-color: orange; margin-right: 5px;"></div> <div style="width: 7%; height: 10px; background-color: red; margin-right: 5px;"></div> <div style="width: 1%; height: 10px; background-color: grey;"></div> </div> <p style="font-size: small; margin-top: 5px;">4% 17% 43% 29% 7%</p>

Continued on next page...

Continued from previous page...

Mol	Chain	Length	Quality of chain
2	AA	94	
2	DA	94	
2	FA	94	
2	HA	94	
3	AB	52	
3	DB	52	
3	FB	52	
3	HB	52	
4	AC	109	
4	DC	109	
4	FC	109	
4	HC	109	
5	AE	191	
5	DE	191	
5	FE	191	
5	HE	191	
6	AF	126	
6	DF	126	
6	FF	126	
6	HF	126	
7	AG	104	
7	DG	104	
7	FG	104	
7	HG	104	
8	AH	113	









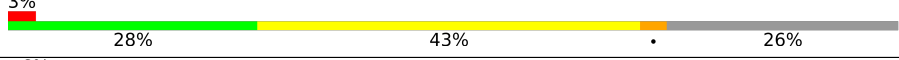
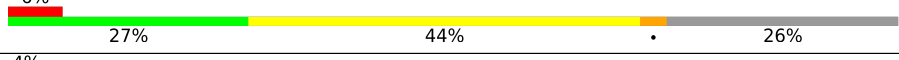
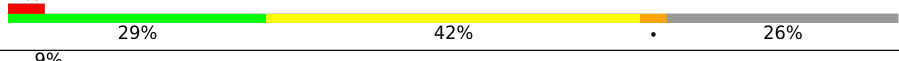
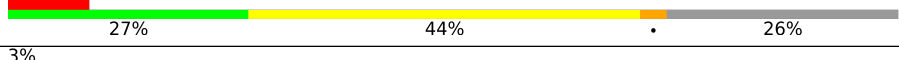
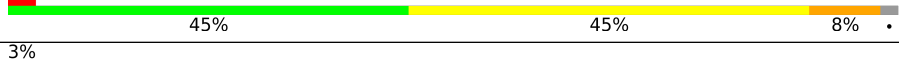
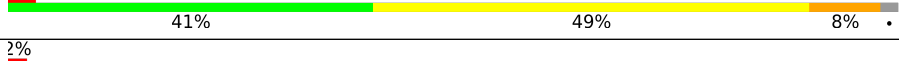
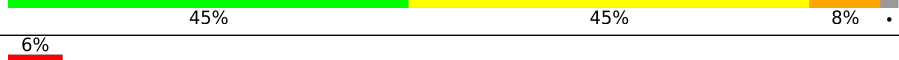

Continued on next page...

Continued from previous page...

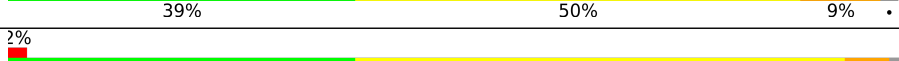
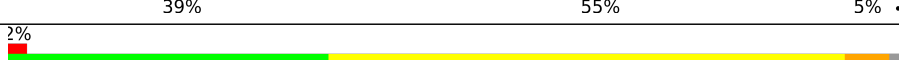
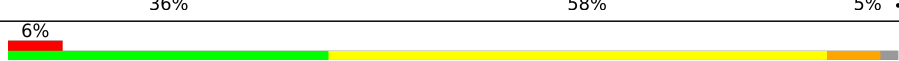
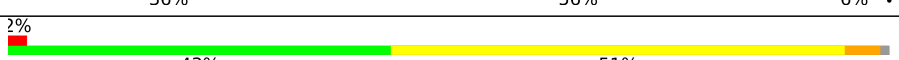
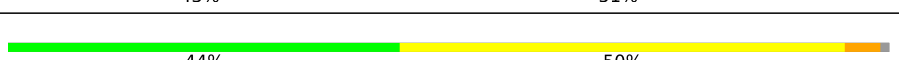
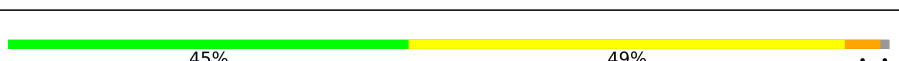
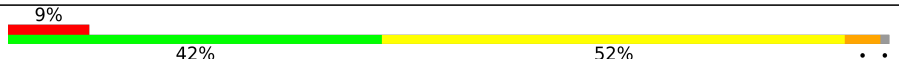
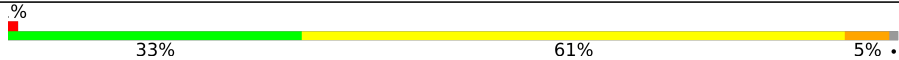
Mol	Chain	Length	Quality of chain
8	DH	113	
8	FH	113	
8	HH	113	
9	AJ	248	
9	DJ	248	
9	FJ	248	
9	HJ	248	
10	AK	129	
10	DK	129	
10	FK	129	
10	HK	129	
11	AL	123	
11	DL	123	
11	FL	123	
11	HL	123	
12	AM	118	
12	DM	118	
12	FM	118	
12	HM	118	
13	AN	144	
13	DN	144	
13	FN	144	
13	HN	144	
14	AO	134	
14	DO	134	

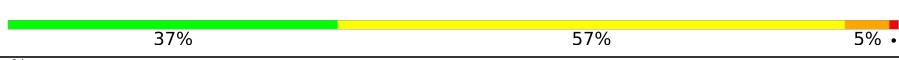
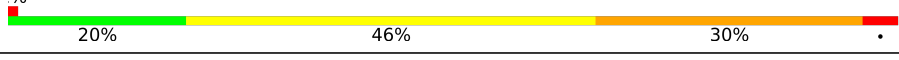

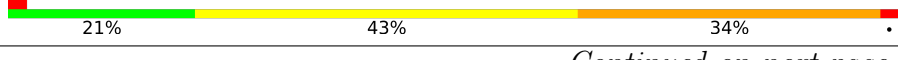



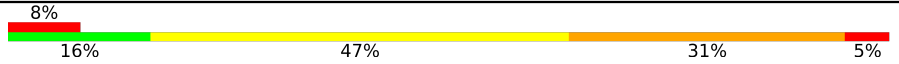
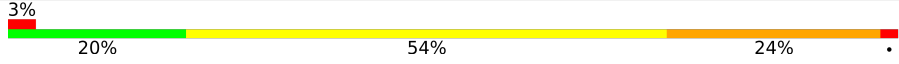
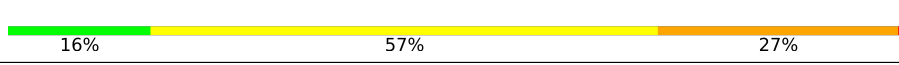
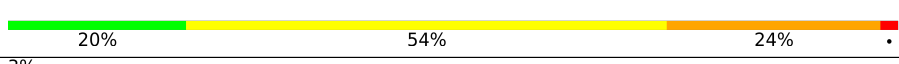
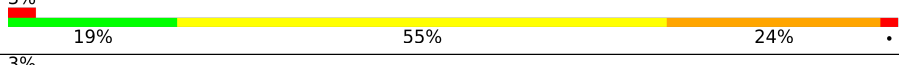
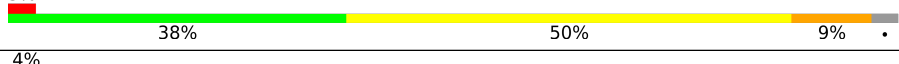
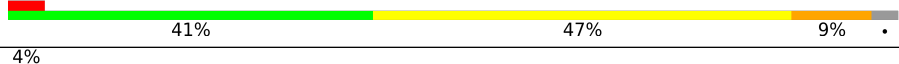
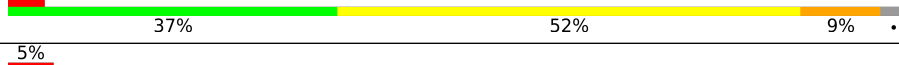
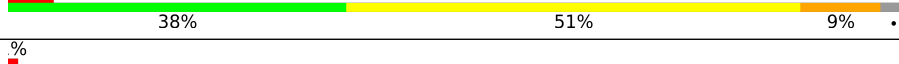
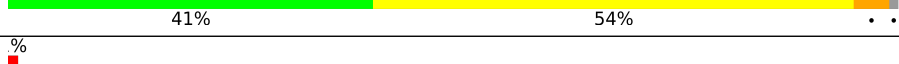

Continued on next page...

Continued from previous page...

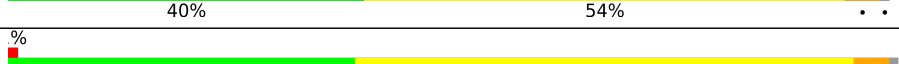
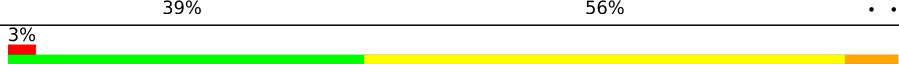
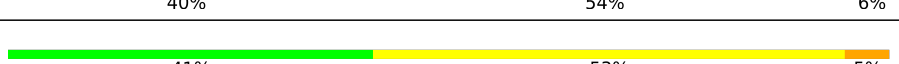
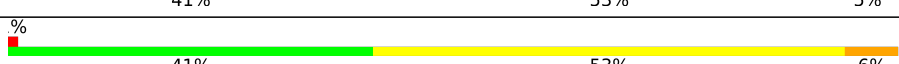
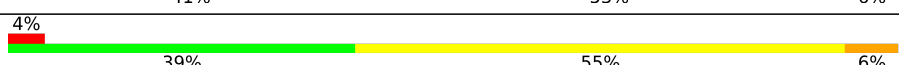
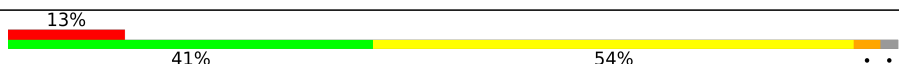
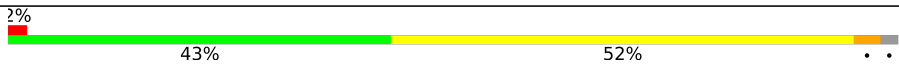
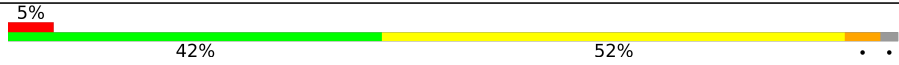
Mol	Chain	Length	Quality of chain
14	FO	134	 % 39% 55% 6%
14	HO	134	 8% 42% 54%
15	AP	89	 3% 28% 43% 26%
15	DP	89	 6% 27% 44% 26%
15	FP	89	 4% 29% 42% 26%
15	HP	89	 9% 27% 44% 26%
16	AQ	104	 3% 45% 45% 8%
16	DQ	104	 3% 41% 49% 8%
16	FQ	104	 2% 45% 45% 8%
16	HQ	104	 6% 45% 45% 8%
17	AT	66	 6% 39% 50% 9%
17	DT	66	 2% 39% 55% 5%
17	FT	66	 2% 36% 58% 5%
17	HT	66	 6% 36% 56% 6%
18	AU	206	 2% 43% 51%
18	DU	206	 44% 50%
18	FU	206	 45% 49%
18	HU	206	 9% 42% 52%
19	AX	189	 % 33% 61% 5%
19	DX	189	 % 33% 60% 6%
19	FX	189	 % 34% 59% 6%
19	HX	189	 % 37% 57% 5%
20	B2	154	 % 20% 46% 30%
20	C2	154	 % 18% 47% 32%
20	E2	154	 2% 21% 43% 34%

Continued on next page...

Continued from previous page...

Mol	Chain	Length	Quality of chain
20	G2	154	
21	B3	120	
21	C3	120	
21	E3	120	
21	G3	120	
22	BA	264	
22	CA	264	
22	EA	264	
22	GA	264	
23	BB	391	
23	CB	391	
23	EB	391	
23	GB	391	
24	BC	410	
24	CC	410	
24	EC	410	
24	GC	410	
25	BD	172	
25	CD	172	
25	ED	172	
25	GD	172	
26	BE	188	
26	CE	188	
26	EE	188	
26	GE	188	













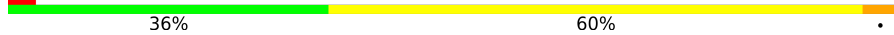
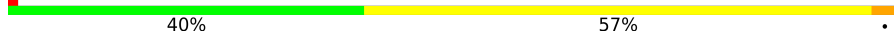
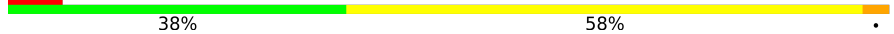
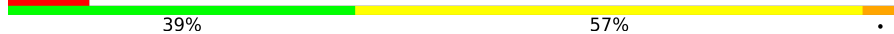
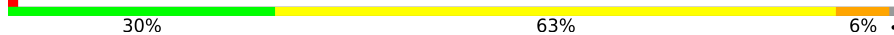
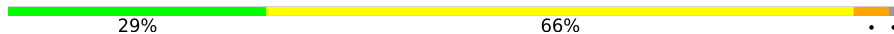
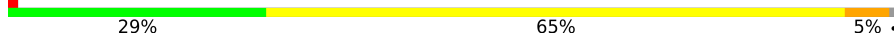
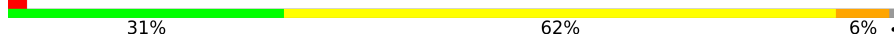

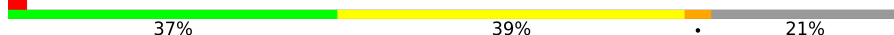
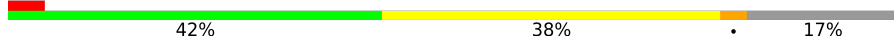

Continued on next page...

Continued from previous page...

Mol	Chain	Length	Quality of chain
27	BF	255	3% 39% 49% 9%
27	CF	255	% 37% 51% 9%
27	EF	255	2% 38% 49% 9%
27	GF	255	7% 38% 49% 9%
28	BG	123	65% 35%
28	CG	123	65% 35%
28	EG	123	67% 33%
28	GG	123	61% 39%
29	BH	215	3% 35% 54% 7%
29	CH	215	32% 58% 7%
29	EH	215	% 32% 57% 7%
29	GH	215	% 33% 56% 5% 7%
30	BI	198	% 37% 57% 6%
30	CI	198	36% 59% 6%
30	EI	198	% 39% 57% 3%
30	GI	198	% 38% 56% 6%
31	BJ	141	55% 41%
31	CJ	141	57% 40%
31	EJ	141	2% 56% 40%
31	GJ	141	% 55% 40%
32	BK	149	3% 37% 54% 7%
32	CK	149	38% 54% 7%
32	EK	149	36% 54% 8%
32	GK	149	7% 37% 54% 7%
33	BL	204	43% 54%

Continued on next page...

Continued from previous page...

Mol	Chain	Length	Quality of chain
33	CL	204	 38% 58%
33	EL	204	 38% 59%
33	GL	204	 37% 58%
34	BM	301	 36% 60%
34	CM	301	 40% 57%
34	EM	301	 38% 58%
34	GM	301	 39% 57%
35	BN	181	 30% 63% 6%
35	CN	181	 29% 66%
35	EN	181	 29% 65% 5%
35	GN	181	 31% 62% 6%
36	BO	185	 49% 48%
36	EO	185	 37% 39% 21%
36	GO	185	 42% 38% 17%
37	BP	157	 44% 50% 5%
37	CP	157	 46% 48%
37	EP	157	 45% 50%
37	GP	157	 46% 48% 5%
38	BQ	183	 39% 41% 5% 14%
38	CQ	183	 37% 42% 7% 14%
38	EQ	183	 39% 40% 7% 14%
38	GQ	183	 35% 44% 7% 14%
39	BR	150	 37% 40% 19%
39	CR	150	 36% 42% 19%
39	ER	150	 34% 43% 19%

Continued on next page...







Continued from previous page...

Mol	Chain	Length	Quality of chain
39	GR	150	6% 34% 43% 19%
40	BS	135	41% 47% 5% 7%
40	CS	135	3% 39% 49% 6% 7%
40	ES	135	4% 41% 48% 7%
40	GS	135	7% 40% 47% 6% 7%
41	BT	158	12% 25% 61%
41	CT	158	11% 25% 61%
41	ET	158	11% 25% 61%
41	GT	158	13% 23% 61%
42	BU	124	39% 54% 6%
42	CU	124	37% 55% 7%
42	EU	124	2% 37% 56% 6%
42	GU	124	15% 35% 58% 6%
43	BV	239	38% 56% 6%
43	CV	239	35% 59% 6%
43	EV	239	35% 59% 5%
43	GV	239	34% 59% 6%
44	BW	111	2% 53% 42% 5%
44	CW	111	50% 45% 5%
44	EW	111	51% 43% 5%
44	GW	111	50% 46% 4%
45	BX	134	37% 46% 11% 7%
45	CX	134	37% 45% 11% 7%
45	EX	134	36% 46% 11% 7%
45	GX	134	3% 36% 46% 11% 7%

Continued on next page...

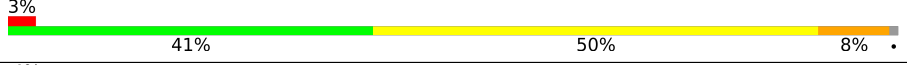
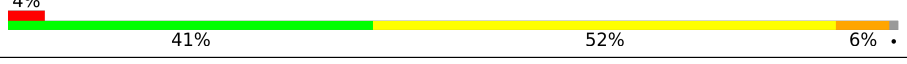
*Continued from previous page...*

Mol	Chain	Length	Quality of chain
46	BY	103	
46	CY	103	
46	EY	103	
46	GY	103	
47	CO	185	

The following table lists non-polymeric compounds, carbohydrate monomers and non-standard residues in protein, DNA, RNA chains that are outliers for geometric or electron-density-fit criteria:

Mol	Type	Chain	Res	Chirality	Geometry	Clashes	Electron density
48	MG	A1	3422	-	-	-	X
48	MG	A1	3428	-	-	-	X
48	MG	A1	3430	-	-	-	X
48	MG	A1	3435	-	-	-	X
48	MG	A1	3437	-	-	-	X
48	MG	A1	3472	-	-	-	X
48	MG	A1	3522	-	-	-	X
48	MG	A1	3530	-	-	-	X
48	MG	A1	3555	-	-	-	X
48	MG	A1	3573	-	-	-	X
48	MG	A1	3579	-	-	-	X
48	MG	A1	3583	-	-	-	X
48	MG	A1	3585	-	-	-	X
48	MG	A1	3587	-	-	-	X
48	MG	A1	3593	-	-	-	X
48	MG	A1	3595	-	-	-	X
48	MG	C3	205	-	-	-	X
48	MG	C3	207	-	-	-	X
48	MG	D1	3424	-	-	-	X
48	MG	D1	3434	-	-	-	X
48	MG	D1	3446	-	-	-	X
48	MG	D1	3463	-	-	-	X
48	MG	D1	3497	-	-	-	X
48	MG	D1	3548	-	-	-	X
48	MG	D1	3550	-	-	-	X
48	MG	D1	3571	-	-	-	X
48	MG	D1	3576	-	-	-	X
48	MG	D1	3592	-	-	-	X

*Continued on next page...*

*Continued from previous page...*

Mol	Type	Chain	Res	Chirality	Geometry	Clashes	Electron density
48	MG	D1	3596	-	-	-	X
48	MG	D1	3597	-	-	-	X
48	MG	D1	3600	-	-	-	X
48	MG	D1	3603	-	-	-	X
48	MG	D1	3606	-	-	-	X
48	MG	D1	3611	-	-	-	X
48	MG	D1	3624	-	-	-	X
48	MG	DJ	301	-	-	-	X
48	MG	E2	205	-	-	-	X
48	MG	E3	204	-	-	-	X
48	MG	F1	3411	-	-	-	X
48	MG	F1	3451	-	-	-	X
48	MG	F1	3493	-	-	-	X
48	MG	F1	3511	-	-	-	X
48	MG	F1	3515	-	-	-	X
48	MG	F1	3539	-	-	-	X
48	MG	F1	3560	-	-	-	X
48	MG	F1	3565	-	-	-	X
48	MG	F1	3566	-	-	-	X
48	MG	F1	3574	-	-	-	X
48	MG	F1	3576	-	-	-	X
48	MG	F1	3578	-	-	-	X
48	MG	G2	204	-	-	-	X
48	MG	G2	206	-	-	-	X
48	MG	G3	202	-	-	-	X
48	MG	G3	205	-	-	-	X
48	MG	GN	201	-	-	-	X
48	MG	GP	201	-	-	-	X
48	MG	H1	3409	-	-	-	X
48	MG	H1	3410	-	-	-	X
48	MG	H1	3412	-	-	-	X
48	MG	H1	3414	-	-	-	X
48	MG	H1	3450	-	-	-	X
48	MG	H1	3479	-	-	-	X
48	MG	H1	3489	-	-	-	X
48	MG	H1	3524	-	-	-	X
48	MG	H1	3531	-	-	-	X
48	MG	H1	3533	-	-	-	X
48	MG	H1	3534	-	-	-	X
48	MG	H1	3535	-	-	-	X
48	MG	H1	3536	-	-	-	X
48	MG	H1	3543	-	-	-	X

*Continued on next page...*

*Continued from previous page...*

<b>Mol</b>	<b>Type</b>	<b>Chain</b>	<b>Res</b>	<b>Chirality</b>	<b>Geometry</b>	<b>Clashes</b>	<b>Electron density</b>
48	MG	H1	3544	-	-	-	X
48	MG	H1	3550	-	-	-	X
48	MG	H1	3551	-	-	-	X
48	MG	H1	3554	-	-	-	X

## 2 Entry composition [i](#)

There are 50 unique types of molecules in this entry. The entry contains 511395 atoms, of which 0 are hydrogens and 0 are deuteriums.

In the tables below, the ZeroOcc column contains the number of atoms modelled with zero occupancy, the AltConf column contains the number of residues with at least one atom in alternate conformation and the Trace column contains the number of residues modelled with at most 2 atoms.

- Molecule 1 is a RNA chain called 26S RRNA.

Mol	Chain	Residues	Atoms					ZeroOcc	AltConf	Trace
			Total	C	N	O	P			
1	A1	3119	66769	29861	12195	21594	3119	0	0	0
1	D1	3119	66769	29861	12195	21594	3119	0	0	0
1	F1	3119	66769	29861	12195	21594	3119	0	0	0
1	H1	3119	66769	29861	12195	21594	3119	0	0	0

- Molecule 2 is a protein called RIBOSOMAL PROTEIN L37.

Mol	Chain	Residues	Atoms					ZeroOcc	AltConf	Trace
			Total	C	N	O	S			
2	AA	91	721	440	158	116	7	0	0	0
2	DA	91	721	440	158	116	7	0	0	0
2	FA	91	721	440	158	116	7	0	0	0
2	HA	91	721	440	158	116	7	0	0	0

- Molecule 3 is a protein called RPL39.

Mol	Chain	Residues	Atoms					ZeroOcc	AltConf	Trace
			Total	C	N	O	S			
3	AB	51	456	288	97	70	1	0	0	0
3	DB	51	456	288	97	70	1	0	0	0
3	FB	51	456	288	97	70	1	0	0	0
3	HB	51	456	288	97	70	1	0	0	0

- Molecule 4 is a protein called 60S RIBOSOMAL PROTEIN L36A.

Mol	Chain	Residues	Atoms					ZeroOcc	AltConf	Trace
			Total	C	N	O	S			
4	AC	103	Total 836	C 526	N 163	O 140	S 7	0	0	0
4	DC	103	Total 836	C 526	N 163	O 140	S 7	0	0	0
4	FC	103	Total 836	C 526	N 163	O 140	S 7	0	0	0
4	HC	103	Total 836	C 526	N 163	O 140	S 7	0	0	0

- Molecule 5 is a protein called RPL6.

Mol	Chain	Residues	Atoms					ZeroOcc	AltConf	Trace
			Total	C	N	O	S			
5	AE	190	Total 1525	C 966	N 286	O 272	S 1	0	0	0
5	DE	190	Total 1525	C 966	N 286	O 272	S 1	0	0	0
5	FE	190	Total 1525	C 966	N 286	O 272	S 1	0	0	0
5	HE	190	Total 1525	C 966	N 286	O 272	S 1	0	0	0

- Molecule 6 is a protein called RPL14.

Mol	Chain	Residues	Atoms					ZeroOcc	AltConf	Trace
			Total	C	N	O	S			
6	AF	125	Total 1021	C 659	N 192	O 169	S 1	0	0	0
6	DF	125	Total 1021	C 659	N 192	O 169	S 1	0	0	0
6	FF	125	Total 1021	C 659	N 192	O 169	S 1	0	0	0
6	HF	125	Total 1021	C 659	N 192	O 169	S 1	0	0	0

- Molecule 7 is a protein called RPL30.

Mol	Chain	Residues	Atoms					ZeroOcc	AltConf	Trace
			Total	C	N	O	S			
7	AG	96	Total 727	C 455	N 129	O 138	S 5	0	0	0
7	DG	96	Total 727	C 455	N 129	O 138	S 5	0	0	0
7	FG	96	Total 727	C 455	N 129	O 138	S 5	0	0	0

*Continued on next page...*

*Continued from previous page...*

Mol	Chain	Residues	Atoms					ZeroOcc	AltConf	Trace
			Total	C	N	O	S			
7	HG	96	727	455	129	138	5	0	0	0

- Molecule 8 is a protein called RPL35A.

Mol	Chain	Residues	Atoms					ZeroOcc	AltConf	Trace
			Total	C	N	O	S			
8	AH	107	850	540	167	142	1	0	0	0
8	DH	107	850	540	167	142	1	0	0	0
8	FH	107	850	540	167	142	1	0	0	0
8	HH	107	850	540	167	142	1	0	0	0

- Molecule 9 is a protein called TRANSLATION INITIATION FACTOR EIF-6, PUTATIVE FAMILY PROTEIN.

Mol	Chain	Residues	Atoms					ZeroOcc	AltConf	Trace
			Total	C	N	O	S			
9	AJ	226	1716	1068	302	336	10	0	0	0
9	DJ	226	1716	1068	302	336	10	0	0	0
9	FJ	226	1716	1068	302	336	10	0	0	0
9	HJ	226	1716	1068	302	336	10	0	0	0

There are 12 discrepancies between the modelled and reference sequences:

Chain	Residue	Modelled	Actual	Comment	Reference
AJ	-2	GLY	-	expression tag	UNP Q245F2
AJ	-1	THR	-	expression tag	UNP Q245F2
AJ	0	SER	-	expression tag	UNP Q245F2
DJ	-2	GLY	-	expression tag	UNP Q245F2
DJ	-1	THR	-	expression tag	UNP Q245F2
DJ	0	SER	-	expression tag	UNP Q245F2
FJ	-2	GLY	-	expression tag	UNP Q245F2
FJ	-1	THR	-	expression tag	UNP Q245F2
FJ	0	SER	-	expression tag	UNP Q245F2
HJ	-2	GLY	-	expression tag	UNP Q245F2
HJ	-1	THR	-	expression tag	UNP Q245F2

*Continued on next page...*

*Continued from previous page...*

Chain	Residue	Modelled	Actual	Comment	Reference
HJ	0	SER	-	expression tag	UNP Q245F2

- Molecule 10 is a protein called UBIQUITIN-60S RIBOSOMAL PROTEIN L40.

Mol	Chain	Residues	Atoms					ZeroOcc	AltConf	Trace
10	AK	52	Total	C	N	O	S	0	0	0
			415	257	83	69	6			
10	DK	52	Total	C	N	O	S	0	0	0
			415	257	83	69	6			
10	FK	52	Total	C	N	O	S	0	0	0
			415	257	83	69	6			
10	HK	52	Total	C	N	O	S	0	0	0
			415	257	83	69	6			

- Molecule 11 is a protein called RPL34.

Mol	Chain	Residues	Atoms					ZeroOcc	AltConf	Trace
11	AL	108	Total	C	N	O	S	0	0	0
			852	529	170	147	6			
11	DL	108	Total	C	N	O	S	0	0	0
			852	529	170	147	6			
11	FL	108	Total	C	N	O	S	0	0	0
			852	529	170	147	6			
11	HL	108	Total	C	N	O	S	0	0	0
			852	529	170	147	6			

- Molecule 12 is a protein called RIBOSOMAL PROTEIN L22.

Mol	Chain	Residues	Atoms					ZeroOcc	AltConf	Trace
12	AM	100	Total	C	N	O	S	0	0	0
			819	530	137	151	1			
12	DM	100	Total	C	N	O	S	0	0	0
			819	530	137	151	1			
12	FM	100	Total	C	N	O	S	0	0	0
			819	530	137	151	1			
12	HM	100	Total	C	N	O	S	0	0	0
			819	530	137	151	1			

- Molecule 13 is a protein called RPL27.



Mol	Chain	Residues	Atoms					ZeroOcc	AltConf	Trace
13	AN	143	Total	C	N	O	S	0	0	0
			1170	755	213	199	3			
13	DN	143	Total	C	N	O	S	0	0	0
			1170	755	213	199	3			
13	FN	143	Total	C	N	O	S	0	0	0
			1170	755	213	199	3			
13	HN	143	Total	C	N	O	S	0	0	0
			1170	755	213	199	3			

- Molecule 14 is a protein called RPL28.

Mol	Chain	Residues	Atoms					ZeroOcc	AltConf	Trace
14	AO	134	Total	C	N	O	S	0	0	0
			1034	650	204	179	1			
14	DO	134	Total	C	N	O	S	0	0	0
			1034	650	204	179	1			
14	FO	134	Total	C	N	O	S	0	0	0
			1034	650	204	179	1			
14	HO	134	Total	C	N	O	S	0	0	0
			1034	650	204	179	1			

- Molecule 15 is a protein called RPL38.

Mol	Chain	Residues	Atoms					ZeroOcc	AltConf	Trace
15	AP	66	Total	C	N	O	S	0	0	0
			551	367	93	90	1			
15	DP	66	Total	C	N	O	S	0	0	0
			551	367	93	90	1			
15	FP	66	Total	C	N	O	S	0	0	0
			551	367	93	90	1			
15	HP	66	Total	C	N	O	S	0	0	0
			551	367	93	90	1			

- Molecule 16 is a protein called 60S RIBOSOMAL PROTEIN L36.

Mol	Chain	Residues	Atoms				ZeroOcc	AltConf	Trace
16	AQ	102	Total	C	N	O	0	0	0
			803	506	165	132			
16	DQ	102	Total	C	N	O	0	0	0
			803	506	165	132			
16	FQ	102	Total	C	N	O	0	0	0
			803	506	165	132			

*Continued on next page...*

*Continued from previous page...*

Mol	Chain	Residues	Atoms				ZeroOcc	AltConf	Trace
			Total	C	N	O			
16	HQ	102	803	506	165	132	0	0	0

- Molecule 17 is a protein called RPL29.

Mol	Chain	Residues	Atoms				ZeroOcc	AltConf	Trace
			Total	C	N	O			
17	AT	65	533	324	117	92	0	0	0
17	DT	65	533	324	117	92	0	0	0
17	FT	65	533	324	117	92	0	0	0
17	HT	65	533	324	117	92	0	0	0

- Molecule 18 is a protein called RPL13.

Mol	Chain	Residues	Atoms					ZeroOcc	AltConf	Trace
			Total	C	N	O	S			
18	AU	203	1624	1015	328	279	2	0	0	0
18	DU	203	1624	1015	328	279	2	0	0	0
18	FU	203	1624	1015	328	279	2	0	0	0
18	HU	203	1624	1015	328	279	2	0	0	0

- Molecule 19 is a protein called RPL18A.

Mol	Chain	Residues	Atoms					ZeroOcc	AltConf	Trace
			Total	C	N	O	S			
19	AX	188	1536	972	287	271	6	0	0	0
19	DX	188	1536	972	287	271	6	0	0	0
19	FX	188	1536	972	287	271	6	0	0	0
19	HX	188	1536	972	287	271	6	0	0	0

- Molecule 20 is a RNA chain called 5.8S RRNA.

Mol	Chain	Residues	Atoms					ZeroOcc	AltConf	Trace
20	B2	154	Total	C	N	O	P	0	0	0
			3300	1475	602	1069	154			
20	C2	154	Total	C	N	O	P	0	0	0
			3300	1475	602	1069	154			
20	E2	154	Total	C	N	O	P	0	0	0
			3300	1475	602	1069	154			
20	G2	154	Total	C	N	O	P	0	0	0
			3300	1475	602	1069	154			

- Molecule 21 is a RNA chain called 5S RRNA.

Mol	Chain	Residues	Atoms					ZeroOcc	AltConf	Trace
21	B3	120	Total	C	N	O	P	0	0	0
			2566	1145	463	838	120			
21	C3	120	Total	C	N	O	P	0	0	0
			2566	1145	463	838	120			
21	E3	120	Total	C	N	O	P	0	0	0
			2566	1145	463	838	120			
21	G3	120	Total	C	N	O	P	0	0	0
			2566	1145	463	838	120			

- Molecule 22 is a protein called RPL8.

Mol	Chain	Residues	Atoms					ZeroOcc	AltConf	Trace
22	BA	257	Total	C	N	O	S	0	0	0
			1977	1226	400	343	8			
22	CA	257	Total	C	N	O	S	0	0	0
			1977	1226	400	343	8			
22	EA	257	Total	C	N	O	S	0	0	0
			1977	1226	400	343	8			
22	GA	257	Total	C	N	O	S	0	0	0
			1977	1226	400	343	8			

- Molecule 23 is a protein called RIBOSOMAL PROTEIN L3.

Mol	Chain	Residues	Atoms					ZeroOcc	AltConf	Trace
23	BB	386	Total	C	N	O	S	0	0	0
			3080	1944	595	530	11			
23	CB	386	Total	C	N	O	S	0	0	0
			3080	1944	595	530	11			
23	EB	386	Total	C	N	O	S	0	0	0
			3080	1944	595	530	11			

*Continued on next page...*

*Continued from previous page...*

Mol	Chain	Residues	Atoms					ZeroOcc	AltConf	Trace
			Total	C	N	O	S			
23	GB	386	3080	1944	595	530	11	0	0	0

- Molecule 24 is a protein called RPL4.

Mol	Chain	Residues	Atoms					ZeroOcc	AltConf	Trace
			Total	C	N	O	S			
24	BC	409	3172	1975	622	571	4	0	0	0
24	CC	409	3172	1975	622	571	4	0	0	0
24	EC	409	3172	1975	622	571	4	0	0	0
24	GC	409	3172	1975	622	571	4	0	0	0

- Molecule 25 is a protein called 60S RIBOSOMAL PROTEIN L11.

Mol	Chain	Residues	Atoms					ZeroOcc	AltConf	Trace
			Total	C	N	O	S			
25	BD	169	1357	851	254	243	9	0	0	0
25	CD	169	1357	851	254	243	9	0	0	0
25	ED	169	1357	851	254	243	9	0	0	0
25	GD	169	1357	851	254	243	9	0	0	0

- Molecule 26 is a protein called 60S RIBOSOMAL PROTEIN L9.

Mol	Chain	Residues	Atoms					ZeroOcc	AltConf	Trace
			Total	C	N	O	S			
26	BE	186	1481	939	272	264	6	0	0	0
26	CE	186	1481	939	272	264	6	0	0	0
26	EE	186	1481	939	272	264	6	0	0	0
26	GE	186	1481	939	272	264	6	0	0	0

- Molecule 27 is a protein called RPL7A.

Mol	Chain	Residues	Atoms					ZeroOcc	AltConf	Trace
27	BF	231	Total	C	N	O	S	0	0	0
			1860	1191	341	327	1			
27	CF	231	Total	C	N	O	S	0	0	0
			1860	1191	341	327	1			
27	EF	231	Total	C	N	O	S	0	0	0
			1860	1191	341	327	1			
27	GF	231	Total	C	N	O	S	0	0	0
			1860	1191	341	327	1			

- Molecule 28 is a protein called RPLP0.

Mol	Chain	Residues	Atoms				ZeroOcc	AltConf	Trace
28	BG	123	Total	C	N	O	0	0	0
			711	465	123	123			
28	CG	123	Total	C	N	O	0	0	0
			711	465	123	123			
28	EG	123	Total	C	N	O	0	0	0
			711	465	123	123			
28	GG	123	Total	C	N	O	0	0	0
			711	465	123	123			

- Molecule 29 is a protein called 60S RIBOSOMAL PROTEIN L10.

Mol	Chain	Residues	Atoms					ZeroOcc	AltConf	Trace
29	BH	201	Total	C	N	O	S	0	0	0
			1620	1027	319	271	3			
29	CH	201	Total	C	N	O	S	0	0	0
			1620	1027	319	271	3			
29	EH	201	Total	C	N	O	S	0	0	0
			1620	1027	319	271	3			
29	GH	201	Total	C	N	O	S	0	0	0
			1620	1027	319	271	3			

- Molecule 30 is a protein called 60S RIBOSOMAL PROTEIN L13A.

Mol	Chain	Residues	Atoms					ZeroOcc	AltConf	Trace
30	BI	198	Total	C	N	O	S	0	0	0
			1594	1019	308	263	4			
30	CI	198	Total	C	N	O	S	0	0	0
			1594	1019	308	263	4			
30	EI	198	Total	C	N	O	S	0	0	0
			1594	1019	308	263	4			

*Continued on next page...*

*Continued from previous page...*

Mol	Chain	Residues	Atoms					ZeroOcc	AltConf	Trace
			Total	C	N	O	S			
30	GI	198	1594	1019	308	263	4	0	0	0

- Molecule 31 is a protein called RPL23.

Mol	Chain	Residues	Atoms					ZeroOcc	AltConf	Trace
			Total	C	N	O	S			
31	BJ	138	1022	643	193	179	7	0	0	0
31	CJ	138	1022	643	193	179	7	0	0	0
31	EJ	138	1022	643	193	179	7	0	0	0
31	GJ	138	1022	643	193	179	7	0	0	0

- Molecule 32 is a protein called 60S RIBOSOMAL PROTEIN L27A.

Mol	Chain	Residues	Atoms					ZeroOcc	AltConf	Trace
			Total	C	N	O	S			
32	BK	148	1161	739	234	182	6	0	0	0
32	CK	148	1161	739	234	182	6	0	0	0
32	EK	148	1161	739	234	182	6	0	0	0
32	GK	148	1161	739	234	182	6	0	0	0

- Molecule 33 is a protein called RIBOSOMAL PROTEIN L15.

Mol	Chain	Residues	Atoms					ZeroOcc	AltConf	Trace
			Total	C	N	O	S			
33	BL	203	1691	1061	351	275	4	0	0	0
33	CL	203	1691	1061	351	275	4	0	0	0
33	EL	203	1691	1061	351	275	4	0	0	0
33	GL	203	1691	1061	351	275	4	0	0	0

- Molecule 34 is a protein called 60S RIBOSOMAL PROTEIN L5.

Mol	Chain	Residues	Atoms					ZeroOcc	AltConf	Trace
34	BM	298	Total	C	N	O	S	0	0	0
			2409	1530	445	430	4			
34	CM	300	Total	C	N	O	S	0	0	0
			2424	1541	447	432	4			
34	EM	300	Total	C	N	O	S	0	0	0
			2424	1541	447	432	4			
34	GM	300	Total	C	N	O	S	0	0	0
			2424	1541	447	432	4			

- Molecule 35 is a protein called RPL18.

Mol	Chain	Residues	Atoms					ZeroOcc	AltConf	Trace
35	BN	180	Total	C	N	O	S	0	0	0
			1441	909	280	249	3			
35	CN	180	Total	C	N	O	S	0	0	0
			1441	909	280	249	3			
35	EN	180	Total	C	N	O	S	0	0	0
			1441	909	280	249	3			
35	GN	180	Total	C	N	O	S	0	0	0
			1441	909	280	249	3			

- Molecule 36 is a protein called RPL19.

Mol	Chain	Residues	Atoms					ZeroOcc	AltConf	Trace
36	BO	184	Total	C	N	O	S	0	0	0
			1491	924	311	251	5			
36	EO	146	Total	C	N	O	S	0	0	0
			1192	745	249	193	5			
36	GO	153	Total	C	N	O	S	0	0	0
			1234	772	256	201	5			

- Molecule 37 is a protein called 60S RIBOSOMAL PROTEIN L21.

Mol	Chain	Residues	Atoms					ZeroOcc	AltConf	Trace
37	BP	156	Total	C	N	O	S	0	0	0
			1272	804	251	215	2			
37	CP	156	Total	C	N	O	S	0	0	0
			1272	804	251	215	2			
37	EP	156	Total	C	N	O	S	0	0	0
			1272	804	251	215	2			
37	GP	156	Total	C	N	O	S	0	0	0
			1272	804	251	215	2			

- Molecule 38 is a protein called RPL17.

Mol	Chain	Residues	Atoms					ZeroOcc	AltConf	Trace
38	BQ	157	Total	C	N	O	S	0	0	0
			1239	771	249	216	3			
38	CQ	157	Total	C	N	O	S	0	0	0
			1239	771	249	216	3			
38	EQ	157	Total	C	N	O	S	0	0	0
			1239	771	249	216	3			
38	GQ	157	Total	C	N	O	S	0	0	0
			1239	771	249	216	3			

- Molecule 39 is a protein called RPL23A.

Mol	Chain	Residues	Atoms					ZeroOcc	AltConf	Trace
39	BR	121	Total	C	N	O	S	0	0	0
			965	613	176	173	3			
39	CR	121	Total	C	N	O	S	0	0	0
			965	613	176	173	3			
39	ER	121	Total	C	N	O	S	0	0	0
			965	613	176	173	3			
39	GR	121	Total	C	N	O	S	0	0	0
			965	613	176	173	3			

- Molecule 40 is a protein called RPL26.

Mol	Chain	Residues	Atoms					ZeroOcc	AltConf	Trace
40	BS	126	Total	C	N	O	S	0	0	0
			1013	638	200	173	2			
40	CS	126	Total	C	N	O	S	0	0	0
			1013	638	200	173	2			
40	ES	126	Total	C	N	O	S	0	0	0
			1013	638	200	173	2			
40	GS	126	Total	C	N	O	S	0	0	0
			1013	638	200	173	2			

- Molecule 41 is a protein called RPL24.

Mol	Chain	Residues	Atoms					ZeroOcc	AltConf	Trace
41	BT	61	Total	C	N	O	S	0	0	0
			510	331	100	76	3			
41	CT	61	Total	C	N	O	S	0	0	0
			510	331	100	76	3			
41	ET	61	Total	C	N	O	S	0	0	0
			510	331	100	76	3			

*Continued on next page...*



*Continued from previous page...*

Mol	Chain	Residues	Atoms					ZeroOcc	AltConf	Trace
			Total	C	N	O	S			
41	GT	61	Total 510	C 331	N 100	O 76	S 3	0	0	0

- Molecule 42 is a protein called RPL35.

Mol	Chain	Residues	Atoms				ZeroOcc	AltConf	Trace
			Total	C	N	O			
42	BU	123	Total 990	C 629	N 196	O 165	0	0	0
42	CU	123	Total 990	C 629	N 196	O 165	0	0	0
42	EU	123	Total 990	C 629	N 196	O 165	0	0	0
42	GU	123	Total 990	C 629	N 196	O 165	0	0	0

- Molecule 43 is a protein called 60S RIBOSOMAL PROTEIN L7.

Mol	Chain	Residues	Atoms					ZeroOcc	AltConf	Trace
			Total	C	N	O	S			
43	BV	234	Total 1910	C 1221	N 362	O 323	S 4	0	0	0
43	CV	234	Total 1910	C 1221	N 362	O 323	S 4	0	0	0
43	EV	234	Total 1910	C 1221	N 362	O 323	S 4	0	0	0
43	GV	234	Total 1910	C 1221	N 362	O 323	S 4	0	0	0

- Molecule 44 is a protein called 60S RIBOSOMAL PROTEIN L31.

Mol	Chain	Residues	Atoms					ZeroOcc	AltConf	Trace
			Total	C	N	O	S			
44	BW	110	Total 901	C 563	N 171	O 164	S 3	0	0	0
44	CW	110	Total 901	C 563	N 171	O 164	S 3	0	0	0
44	EW	110	Total 901	C 563	N 171	O 164	S 3	0	0	0
44	GW	110	Total 901	C 563	N 171	O 164	S 3	0	0	0

- Molecule 45 is a protein called 60S RIBOSOMAL PROTEIN L32.

Mol	Chain	Residues	Atoms					ZeroOcc	AltConf	Trace
45	BX	125	Total	C	N	O	S	0	0	0
			1012	639	205	165	3			
45	CX	125	Total	C	N	O	S	0	0	0
			1012	639	205	165	3			
45	EX	125	Total	C	N	O	S	0	0	0
			1012	639	205	165	3			
45	GX	125	Total	C	N	O	S	0	0	0
			1012	639	205	165	3			

- Molecule 46 is a protein called RPL37A.

Mol	Chain	Residues	Atoms					ZeroOcc	AltConf	Trace
46	BY	102	Total	C	N	O	S	0	0	0
			786	502	148	131	5			
46	CY	102	Total	C	N	O	S	0	0	0
			786	502	148	131	5			
46	EY	102	Total	C	N	O	S	0	0	0
			786	502	148	131	5			
46	GY	102	Total	C	N	O	S	0	0	0
			786	502	148	131	5			

- Molecule 47 is a protein called RPL19.

Mol	Chain	Residues	Atoms					ZeroOcc	AltConf	Trace
47	CO	175	Total	C	N	O	S	0	0	0
			1366	861	278	222	5			

- Molecule 48 is MAGNESIUM ION (three-letter code: MG) (formula: Mg).

Mol	Chain	Residues	Atoms		ZeroOcc	AltConf
48	A1	200	Total	Mg	0	0
			200	200		
48	AA	2	Total	Mg	0	0
			2	2		
48	AK	1	Total	Mg	0	0
			1	1		
48	B2	8	Total	Mg	0	0
			8	8		
48	B3	3	Total	Mg	0	0
			3	3		
48	BJ	1	Total	Mg	0	0
			1	1		

*Continued on next page...*

*Continued from previous page...*

Mol	Chain	Residues	Atoms		ZeroOcc	AltConf
48	BL	1	Total 1	Mg 1	0	0
48	BN	1	Total 1	Mg 1	0	0
48	BP	1	Total 1	Mg 1	0	0
48	BQ	2	Total 2	Mg 2	0	0
48	BW	1	Total 1	Mg 1	0	0
48	C2	6	Total 6	Mg 6	0	0
48	C3	7	Total 7	Mg 7	0	0
48	CD	1	Total 1	Mg 1	0	0
48	CJ	1	Total 1	Mg 1	0	0
48	CL	2	Total 2	Mg 2	0	0
48	CN	1	Total 1	Mg 1	0	0
48	CQ	2	Total 2	Mg 2	0	0
48	CW	1	Total 1	Mg 1	0	0
48	CY	1	Total 1	Mg 1	0	0
48	D1	232	Total 232	Mg 232	0	0
48	DA	2	Total 2	Mg 2	0	0
48	DJ	1	Total 1	Mg 1	0	0
48	DK	1	Total 1	Mg 1	0	0
48	DQ	1	Total 1	Mg 1	0	0
48	E2	7	Total 7	Mg 7	0	0
48	E3	6	Total 6	Mg 6	0	0

*Continued on next page...*

*Continued from previous page...*

Mol	Chain	Residues	Atoms		ZeroOcc	AltConf
48	EJ	1	Total 1	Mg 1	0	0
48	EL	2	Total 2	Mg 2	0	0
48	EN	2	Total 2	Mg 2	0	0
48	EQ	1	Total 1	Mg 1	0	0
48	EW	2	Total 2	Mg 2	0	0
48	F1	184	Total 184	Mg 184	0	0
48	FA	2	Total 2	Mg 2	0	0
48	FK	1	Total 1	Mg 1	0	0
48	FT	1	Total 1	Mg 1	0	0
48	G2	6	Total 6	Mg 6	0	0
48	G3	5	Total 5	Mg 5	0	0
48	GA	1	Total 1	Mg 1	0	0
48	GJ	1	Total 1	Mg 1	0	0
48	GL	1	Total 1	Mg 1	0	0
48	GN	1	Total 1	Mg 1	0	0
48	GO	1	Total 1	Mg 1	0	0
48	GP	2	Total 2	Mg 2	0	0
48	GQ	1	Total 1	Mg 1	0	0
48	GW	1	Total 1	Mg 1	0	0
48	H1	155	Total 155	Mg 155	0	0
48	HT	1	Total 1	Mg 1	0	0

- Molecule 49 is ZINC ION (three-letter code: ZN) (formula: Zn).

Mol	Chain	Residues	Atoms		ZeroOcc	AltConf
49	AA	1	Total 1	Zn 1	0	0
49	AC	1	Total 1	Zn 1	0	0
49	AK	1	Total 1	Zn 1	0	0
49	AL	1	Total 1	Zn 1	0	0
49	BY	1	Total 1	Zn 1	0	0
49	CY	1	Total 1	Zn 1	0	0
49	DA	1	Total 1	Zn 1	0	0
49	DC	1	Total 1	Zn 1	0	0
49	DK	1	Total 1	Zn 1	0	0
49	DL	1	Total 1	Zn 1	0	0
49	EY	1	Total 1	Zn 1	0	0
49	FA	1	Total 1	Zn 1	0	0
49	FC	1	Total 1	Zn 1	0	0
49	FK	1	Total 1	Zn 1	0	0
49	FL	1	Total 1	Zn 1	0	0
49	GY	1	Total 1	Zn 1	0	0
49	HA	1	Total 1	Zn 1	0	0
49	HC	1	Total 1	Zn 1	0	0
49	HK	1	Total 1	Zn 1	0	0
49	HL	1	Total 1	Zn 1	0	0

- Molecule 50 is water.

Mol	Chain	Residues	Atoms		ZeroOcc	AltConf
50	A1	1134	Total 1134	O 1134	0	0
50	AA	8	Total 8	O 8	0	0
50	AB	5	Total 5	O 5	0	0
50	AH	1	Total 1	O 1	0	0
50	AK	3	Total 3	O 3	0	0
50	AM	1	Total 1	O 1	0	0
50	AP	2	Total 2	O 2	0	0
50	AT	3	Total 3	O 3	0	0
50	AU	4	Total 4	O 4	0	0
50	B2	54	Total 54	O 54	0	0
50	B3	23	Total 23	O 23	0	0
50	BA	12	Total 12	O 12	0	0
50	BB	4	Total 4	O 4	0	0
50	BC	7	Total 7	O 7	0	0
50	BE	1	Total 1	O 1	0	0
50	BI	3	Total 3	O 3	0	0
50	BJ	5	Total 5	O 5	0	0
50	BK	3	Total 3	O 3	0	0
50	BL	8	Total 8	O 8	0	0
50	BM	2	Total 2	O 2	0	0
50	BN	5	Total 5	O 5	0	0
50	BO	2	Total 2	O 2	0	0

*Continued on next page...*

*Continued from previous page...*

Mol	Chain	Residues	Atoms		ZeroOcc	AltConf
50	BP	5	Total 5	O 5	0	0
50	BQ	7	Total 7	O 7	0	0
50	BU	1	Total 1	O 1	0	0
50	BV	7	Total 7	O 7	0	0
50	BW	5	Total 5	O 5	0	0
50	BX	6	Total 6	O 6	0	0
50	BY	5	Total 5	O 5	0	0
50	C2	46	Total 46	O 46	0	0
50	C3	39	Total 39	O 39	0	0
50	CA	11	Total 11	O 11	0	0
50	CB	4	Total 4	O 4	0	0
50	CC	7	Total 7	O 7	0	0
50	CD	4	Total 4	O 4	0	0
50	CE	2	Total 2	O 2	0	0
50	CI	1	Total 1	O 1	0	0
50	CJ	4	Total 4	O 4	0	0
50	CK	3	Total 3	O 3	0	0
50	CL	12	Total 12	O 12	0	0
50	CM	6	Total 6	O 6	0	0
50	CN	7	Total 7	O 7	0	0
50	CO	2	Total 2	O 2	0	0

*Continued on next page...*

*Continued from previous page...*

Mol	Chain	Residues	Atoms	ZeroOcc	AltConf
50	CP	6	Total O 6 6	0	0
50	CQ	7	Total O 7 7	0	0
50	CU	1	Total O 1 1	0	0
50	CV	4	Total O 4 4	0	0
50	CW	5	Total O 5 5	0	0
50	CX	6	Total O 6 6	0	0
50	CY	5	Total O 5 5	0	0
50	D1	1341	Total O 1341 1341	0	0
50	DA	10	Total O 10 10	0	0
50	DB	4	Total O 4 4	0	0
50	DE	1	Total O 1 1	0	0
50	DJ	2	Total O 2 2	0	0
50	DK	2	Total O 2 2	0	0
50	DP	1	Total O 1 1	0	0
50	DQ	2	Total O 2 2	0	0
50	DT	4	Total O 4 4	0	0
50	DU	3	Total O 3 3	0	0
50	DX	2	Total O 2 2	0	0
50	E2	44	Total O 44 44	0	0
50	E3	34	Total O 34 34	0	0
50	EA	4	Total O 4 4	0	0

*Continued on next page...*



*Continued from previous page...*

Mol	Chain	Residues	Atoms	ZeroOcc	AltConf
50	EB	3	Total O 3 3	0	0
50	EC	2	Total O 2 2	0	0
50	EE	2	Total O 2 2	0	0
50	EJ	4	Total O 4 4	0	0
50	EK	5	Total O 5 5	0	0
50	EL	10	Total O 10 10	0	0
50	EM	2	Total O 2 2	0	0
50	EN	7	Total O 7 7	0	0
50	EP	6	Total O 6 6	0	0
50	EQ	4	Total O 4 4	0	0
50	EV	6	Total O 6 6	0	0
50	EW	7	Total O 7 7	0	0
50	EX	5	Total O 5 5	0	0
50	EY	5	Total O 5 5	0	0
50	F1	1076	Total O 1076 1076	0	0
50	FA	7	Total O 7 7	0	0
50	FB	4	Total O 4 4	0	0
50	FE	1	Total O 1 1	0	0
50	FH	1	Total O 1 1	0	0
50	FK	2	Total O 2 2	0	0
50	FL	3	Total O 3 3	0	0

*Continued on next page...*

*Continued from previous page...*

Mol	Chain	Residues	Atoms	ZeroOcc	AltConf
50	FP	2	Total O 2 2	0	0
50	FT	4	Total O 4 4	0	0
50	FU	4	Total O 4 4	0	0
50	G2	34	Total O 34 34	0	0
50	G3	26	Total O 26 26	0	0
50	GA	6	Total O 6 6	0	0
50	GB	3	Total O 3 3	0	0
50	GC	2	Total O 2 2	0	0
50	GE	2	Total O 2 2	0	0
50	GI	1	Total O 1 1	0	0
50	GJ	4	Total O 4 4	0	0
50	GK	2	Total O 2 2	0	0
50	GL	5	Total O 5 5	0	0
50	GM	1	Total O 1 1	0	0
50	GN	2	Total O 2 2	0	0
50	GO	2	Total O 2 2	0	0
50	GP	5	Total O 5 5	0	0
50	GQ	4	Total O 4 4	0	0
50	GV	3	Total O 3 3	0	0
50	GW	4	Total O 4 4	0	0
50	GX	5	Total O 5 5	0	0

*Continued on next page...*

*Continued from previous page...*

Mol	Chain	Residues	Atoms		ZeroOcc	AltConf
50	GY	1	Total 1	O 1	0	0
50	H1	924	Total 924	O 924	0	0
50	HA	4	Total 4	O 4	0	0
50	HB	4	Total 4	O 4	0	0
50	HJ	2	Total 2	O 2	0	0
50	HK	2	Total 2	O 2	0	0
50	HP	1	Total 1	O 1	0	0
50	HT	5	Total 5	O 5	0	0
50	HU	2	Total 2	O 2	0	0

### 3 Residue-property plots i

These plots are drawn for all protein, RNA, DNA and oligosaccharide chains in the entry. The first graphic for a chain summarises the proportions of the various outlier classes displayed in the second graphic. The second graphic shows the sequence view annotated by issues in geometry and electron density. Residues are color-coded according to the number of geometric quality criteria for which they contain at least one outlier: green = 0, yellow = 1, orange = 2 and red = 3 or more. A red dot above a residue indicates a poor fit to the electron density ( $RSRZ > 2$ ). Stretches of 2 or more consecutive residues without any outlier are shown as a green connector. Residues present in the sample, but not in the model, are shown in grey.

#### • Molecule 1: 26S RRNA

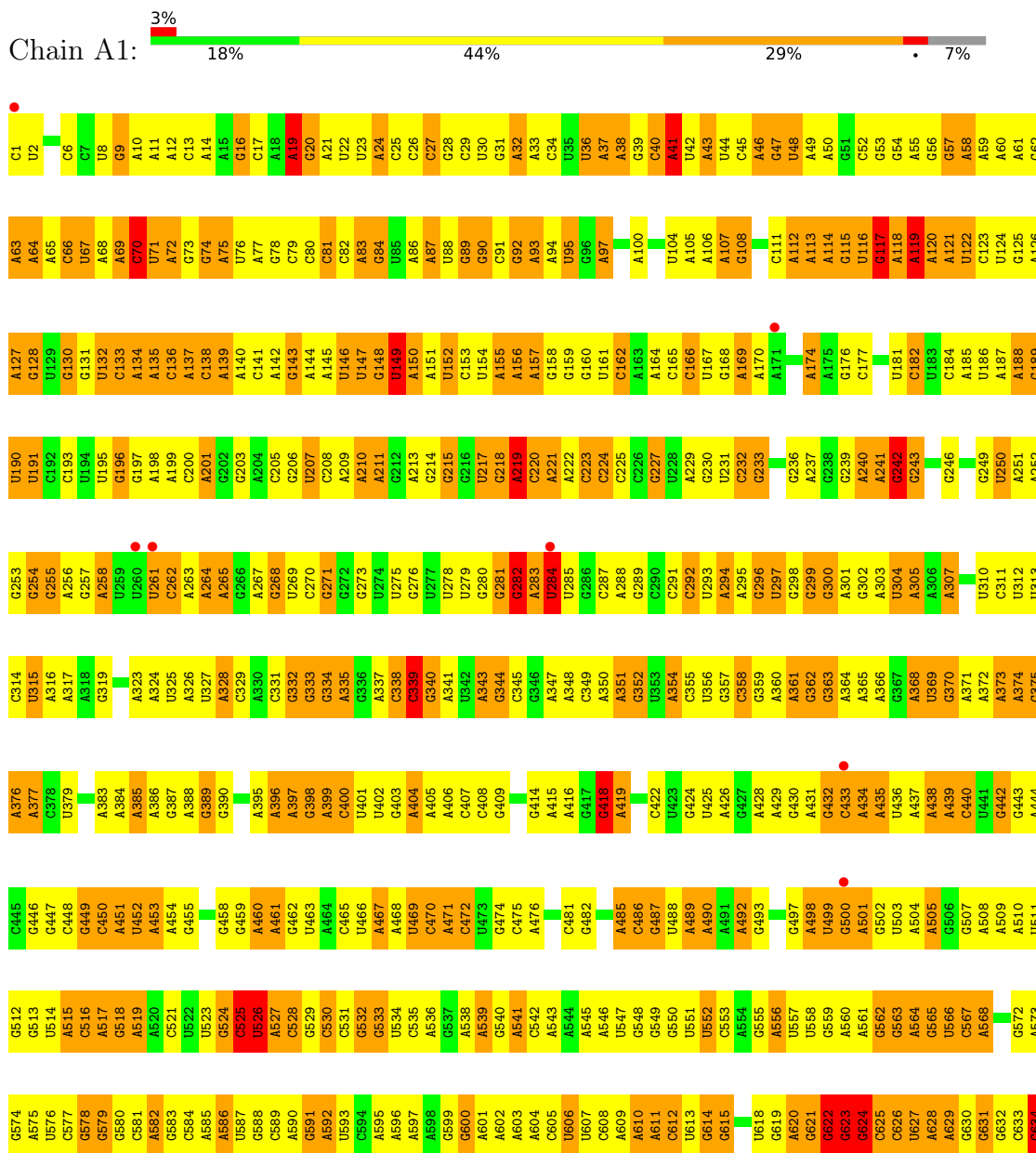

A1459	G1392	G1382	U1332	A1207	C1146	U1083	A1022	U960	G886	U821	C757	A697	A636
G1460	A1593	U1333	G1333	U1208	A1147	G1084	A1023	A961	C886	U822	G757	G698	U636
A1461	G1394	G1334	G1334	G1209	U1148	U1085	A1024	G962	C887	A823	A761	G699	U637
A1462	U1395	U1149	U1149	C1210	U1149	U1086	G1025	C963	C884	G824	G762	G700	U638
C1463	A1396	A1211	A1211	C1211	U1150	A1087	C1026	U954	A895	G825	G763	A701	U639
U1464	G1397	G1212	G1212	C1212	U1151	A1088	G1027	G965	A896	A826	U764	G702	G640
U1465	G1398	G1213	G1213	C1213	U1152	G1089	A1028	G966	A897	C827	A765	U703	U641
G1466	A1399	C1214	C1214	C1214	G1153	A1090	A1029	U967	C898	C828	G766	G704	C642
G1467	G1400	U1215	U1215	C1215	G1154	G1091	U1030	U968	U899	C829	C767	A705	A643
U1468	G1401	C1216	C1216	C1216	U1155	C1092	G1031	C969	U904	G830	A768	U706	A644
G1469	A1402	A1217	A1217	C1217	G1158	G1094	U1034	C970	U905	A831	G769	A707	A645
G1470	C1403	U1218	U1218	C1218	U1159	C1095	U1035	C971	G906	G905	U772	G708	A646
U1471	G1404	C1219	C1219	C1219	G1160	G1096	G1036	C973	A907	A832	U773	U647	U647
A1472	U1405	A1220	A1220	C1220	A1161	G1097	A1037	C974	U908	U836	C773	G710	G648
G1473	G1406	G1221	G1221	C1221	A1162	A1098	A1038	G975	A909	G837	A774	U711	G649
U1474	A1407	A1222	A1222	C1222	A1163	G1099	G1039	G976	U910	G838	C775	G712	G650
A1475	C1408	U1223	U1223	C1223	C1164	A1100	A1040	A977	C911	U839	C776	U651	U651
G1476	G1409	C1224	C1224	C1224	U1165	U1101	U1041	G978	G912	G840	G777	U652	U652
C1477	U1410	C1225	C1225	C1225	G1166	U1102	U1042	U979	C915	A841	A778	A715	C653
U1478	U1411	C1226	C1226	C1226	G1167	A1103	U1043	U980	C916	A842	C780	A716	U654
A1479	U1412	A1227	A1227	C1227	C1168	G1104	G1044	U981	U917	C846	G781	A718	A655
G1480	G1413	G1228	G1228	C1228	U1169	U1105	G1045	C982	U917	C847	G782	C719	C656
U1481	C1414	A1229	A1229	C1229	G1170	U1106	G1046	U983	C918	G847	G783	C720	G658
A1482	C1415	A1230	A1230	C1230	U1171	A1107	G1047	C984	A919	C848	G784	C721	C659
G1483	U1416	U1231	U1231	C1231	G1172	A1108	U1048	U985	A920	U849	G786	G722	C660
U1484	A1417	A1232	A1232	C1232	A1173	U1109	U1049	C986	A921	U850	U787	U723	C661
U1489	U1358	G1233	G1233	C1233	G1174	U1110	C1050	A987	U922	G851	C788	C724	C662
G1490	A1359	U1234	U1234	C1234	U1175	G1111	C1051	U988	G925	A852	U789	C725	G663
A1491	C1360	G1235	G1235	C1235	G1176	U1112	A1052	G989	C926	A853	C790	G726	U664
G1492	U1361	U1236	U1236	C1236	A1177	A1113	G1053	U990	A926	U854	G791	C727	C665
A1493	C1362	U1237	U1237	C1237	U1178	C1114	G1054	U991	G927	A855	C792	U666	U666
A1494	A1363	U1238	U1238	C1238	G1179	U1115	A1055	A992	U928	G856	A793	U729	U667
G1495	U1364	G1239	G1239	C1239	A1180	U1116	C1056	G993	G929	G857	C794	G730	G668
U1496	C1365	A1240	A1240	C1240	A1181	U1117	U1057	C994	U930	G858	G795	A731	A669
G1497	U1366	U1241	U1241	C1241	C1182	U1118	C1058	A995	U931	U859	A796	C732	A670
U1498	A1367	U1242	U1242	C1242	U1183	G1119	U1059	G997	G932	G860	G798	G733	A671
G1499	U1368	G1243	G1243	C1243	U1184	U1120	C1060	A998	G933	A861	A799	A734	C672
A1500	C1369	A1244	A1244	C1244	A1185	A1121	G1061	A999	G934	A862	G799	A735	A673
U1503	G1434	U1245	U1245	C1245	A1186	G1122	A1062	G999	G935	G863	G800	C736	C674
C1504	C1436	C1247	C1247	C1247	C1187	A1125	C1063	G1002	C936	C864	U801	G737	G675
G1505	U1437	G1248	G1248	C1248	U1188	A1126	C1064	A1003	C937	C865	U802	U738	G676
A1506	A1438	G1249	G1249	C1249	U1189	U1127	U1065	G1004	A938	A866	G803	G739	G676
U1507	U1439	A1250	A1250	C1250	G1190	G1128	A1066	U1004	U939	G867	G804	A740	C679
A1508	A1440	C1251	C1251	C1251	G1191	C1129	U1067	A1005	A940	G868	A805	G741	A680
G1509	U1441	G1252	G1252	C1252	A1192	A1130	U1068	C1006	G941	G869	G806	U742	A681
U1510	G1442	A1253	A1253	C1253	G1193	G1131	C1069	G1007	A942	G870	G807	U743	G682
G1511	U1314	C1254	C1254	C1254	A1194	U1132	U1070	C1008	C943	A871	C744	A743	G683
G1512	G1445	A1255	A1255	C1255	U1195	U1133	C1071	A1009	U944	A872	A809	C744	A684
A1513	C1446	G1256	G1256	C1256	A1196	C1134	A1072	G1010	A945	A873	G810	A746	G685
U1516	A1447	A1257	A1257	C1257	A1197	U1135	A1073	U1011	A946	C874	A811	G747	U686
G1517	G1448	A	A	A	G1198	C1136	A1074	U1012	U947	U875	G812	G748	C687
G1518	U1319	C	C	C	G1199	U1137	C1075	U1013	C948	C876	G813	U749	U688
G1519	U1320	G	G	G	C1200	U1138	U1076	U1016	G949	U877	U814	G750	A689
U1520	A1321	U	U	U	G1201	U1139	U1077	U1017	A950	U878	U815	C751	U690
G1521	U1387	G	G	G	C1202	U1140	U1078	U1018	A951	A879	U816	C752	C691
U1522	U1388	G	G	G	C1203	G1142	A1079	A1013	U957	G881	A817	A753	A692
U1486	G1389	C	C	C	C1204	G1143	A1080	G1019	G882	A882	U818	A754	U695
G1523	A1390	G	G	G	A1205	G1144	A1081	G1020	A958	G883	U819	G755	U696
A1524	U1391	U	U	U	A1206	G1145	U1082	U1021	G959	A884	G820	C756	A696

G2371	U2309	G2246	A2178	A2113	U	U1926	U1854	C	A1721	A1653	G1592	U1525
G2372	G2310	A2247	U2179	C2114	U	U1927	U1855	C	U1724	G1654	A1593	G1526
U2375	G2311	G2248	G2180	A2115	U	C1928	C1856	U	U1725	C1655	C1594	A1527
A2376	A2312	U2249	U2181	A2116	G	G1929	G1857	A	A1726	A1656	A1595	G1528
G2377	U2313	G2182	G2182	A2117	C	U1930	U1858	A	U1727	C1657	U1596	
A2378	A2316	U2184	A2183	G2118	U	G1931	C1859		U1728	G1658	U1597	
A2379	G2317	U2185	U2184	G2119	A	A1932	C1861		A1728	A1659	C1598	
U2380	G2318	U2186	U2185	U2120	G	A1933	C1862		U1729	U1660	G1599	
A2381	A2319	C2187	C2187	A2121	C	G1942	A1863		G1730	A1661	G1594	
A2382	G2320	U2188	U2188	U2123	C	U1936	U1864		G1731	A1662	U1601	
U2383	A2321	G2189	G2189	A2124	A	G1937	A1865		C1732	C1663	A1535	
C2384	U2322	C2190	C2190	C2125	G	U1938	A1866		G1733	C1664	U1603	
A2385	U2323	C2191	C2191	G2126	C	C1941	A1867		A1734	C1665	C1604	
G2386	A2324	C2192	C2192	A2127	U	U1942	C1868		U1735	A1666	G1605	
C2387	C2325	A2193	A2193	C2128	U	G1943	C1869		G1736	A1667	U1606	
G2388	C2326	G2194	G2194	U2129	C	U1944	C1870		U1737	A1668	U1607	
C2389	A2327	U2195	U2195	G2130	G	U1945	A1871		A1738	C1669	G1608	
G2390	C2328	G2196	G2196	U2131	C	A1946	U1872		U1739	A1670	U1609	
G2391	U2329	U2197	U2197	U2132	C	C1947	C1873		U1740	C1671	C1610	
A2392	G2330	A2266	A2266	U2133	C	U1948	A1874		U1741	A1672	A1611	
A2393	U2331	G2267	G2267	A2134	G	G1949	C1875		G1742	C1675	A1612	
A2394	C2332	G2268	G2268	A2135	U	U1949	U1876		G1743	A1676	A1613	
G2395	C2333	U2269	U2269	U2136	U	C1950	C1877		A1744	G1677	A1614	
A2396	G2334	A2270	A2270	A2137	C	G1951	A1878		U1745	A1678	G1615	
A2397	U2335	G2271	G2271	A2138	U	U1952	A1879		U1746	C1681	U1549	
G2398	A2336	C2272	C2272	A2139	U	G1953	A1880		U1747	A1682	C1551	
C2400	U2339	A2274	A2274	A2140	G	A1954	C1881		U1748	C1682	U1552	
U2403	A2340	A2275	A2275	A2141	A	U1955	U1882		G1751	U1683	C1553	
G2404	C2341	U2276	U2276	A2142	C	A1956	U1883		U1752	C1684	G1554	
U2405	U2342	G2277	G2277	A2143	C	G1957	A1884		A1753	A1685	G1621	
U2406	G2343	U2278	U2278	A2144	A	U1958	U1885		G1754	C1686	A1622	
G2407	A2344	C2279	C2279	A2145	A	G1963	C1886		U1755	U1691	U1625	
A2408	U2345	G2280	G2280	A2146	U	C1964	U1887		U1756	G1692	G1692	
G2409	A2347	U2281	U2281	C2147	C	U1965	C1888		A1757	U1626	U1627	
C2410	G2348	C2282	C2282	A2148	A	U1966	U1889		U1758	C1693	A1627	
U2411	C2349	G2283	G2283	U2149	C	C1967	U1890		C1759	C1694	A1628	
U2412	G2350	U2284	U2284	U2150	C	U1971	C1891		G1760	C1696	A1630	
G2413	C2351	C2285	C2285	A2154	A	G1972	A1892		A1766	G1698	U1631	
A2414	A2352	A2286	A2286	C2155	G	A1973	C1893		U1767	C1699	U1632	
C2415	C2353	U2289	U2289	G2156	C	U1974	U1903		G1768	G1699	C1633	
U2416	G2354	A2290	A2290	G2157	A	C	A1904		A1769	U1701	G1634	
C2417	C2355	A2291	A2291	C2158	G	G	U1905		A1770	C1635	U1635	
U2418	A2356	U2292	U2292	C2159	A	U	A1906		U1771	G1702	C1636	
A2419	C2357	U2293	U2293	A2162	C	U	U1907		G1772	A1703	C1637	
G2420	A2358	A2294	A2294	G2167	C	G	A1908		G1773	G1704	U1577	
C2422	G2359	U2295	U2295	G2168	G	A	U1909		C1774	A1707	C1578	
U2423	U2361	G2296	G2296	A2165	A	U	A1910		A1775	U1708	U1579	
A2424	A2362	U2297	U2297	G2166	G	A	G1913		G1776	C1709	G1642	
A2425	C2363	G2300	G2300	G2167	A	A	A1917		A1777	U1710	G1643	
C2426	G2364	C2301	C2301	U2168	C	A	U1918		G1778	U1711	A1644	
G2427	G2365	A2299	A2299	G2169	C	G	U1919		A1779	C1645	C1645	
G2428	U2366	C2304	C2304	A2170	G	C	A1920		G1781	G1714	U1646	
A2429	A2367	U2305	U2305	U2171	A	U	A1921		G1782	U1715	U1647	
G2430	C2368	G2306	G2306	G2172	U	U	G1922		U1783	U1716	G1648	
U2431	G2369	A2307	A2307	A2173	G	G	U1923		C1784	U1717	U1649	
A2433	U2370	G2245	G2245	A2177	A	U	A1925		A1785	U1718	A1650	
									C		A1651	
											A1720	
											G1853	

G3276	G3277	G3278	G3279	G3280	G3281	G3282	G3283	G3284	G3285	G3286	G3287	G3288	G3289	G3290	G3291	G3292	G3293	G3294	G3295	G3296	G3297	G3298	G3299	G3300	G3301	G3302	G3303	G3304	G3305	G3306	G3307	G3308	G3309	G3310	G3311	G3312	G3313	G3314	G3315	G3316	G3317	G3318	G3319	G3320	G3321	G3322	G3323	G3324	G3325	G3326	G3327	G3328	G3329	G3330	G3331	G3332	G3333	G3334	G3335	G3336	G3337	G3338	G3339	G3340	G3341	G3342	G3343	G3344	G3345	G3346	G3347	G3348	G3349	G3350	G3351	G3352	G3353	G3354	G3355	G3356	G3357	G3358	G3359	G3360	G3361	G3362	G3363	G3364	G3365	G3366	G3367	G3368	G3369	G3370	G3371	G3372	G3373	G3374	G3375	G3376	G3377	G3378	G3379	G3380	G3381	G3382	G3383	G3384	G3385	G3386	G3387	G3388	G3389	G3390	G3391	G3392	G3393	G3394	G3395	G3396	G3397	G3398	G3399	G3400	G3401	G3402	G3403	G3404	G3405	G3406	G3407	G3408	G3409	G3410	G3411	G3412	G3413	G3414	G3415	G3416	G3417	G3418	G3419	G3420	G3421	G3422	G3423	G3424	G3425	G3426	G3427	G3428	G3429	G3430	G3431	G3432	G3433	G3434	G3435	G3436	G3437	G3438	G3439	G3440	G3441	G3442	G3443	G3444	G3445	G3446	G3447	G3448	G3449	G3450	G3451	G3452	G3453	G3454	G3455	G3456	G3457	G3458	G3459	G3460	G3461	G3462	G3463	G3464	G3465	G3466	G3467	G3468	G3469	G3470	G3471	G3472	G3473	G3474	G3475	G3476	G3477	G3478	G3479	G3480	G3481	G3482	G3483	G3484	G3485	G3486	G3487	G3488	G3489	G3490	G3491	G3492	G3493	G3494	G3495	G3496	G3497	G3498	G3499	G3500	G3501	G3502	G3503	G3504	G3505	G3506	G3507	G3508	G3509	G3510	G3511	G3512	G3513	G3514	G3515	G3516	G3517	G3518	G3519	G3520	G3521	G3522	G3523	G3524	G3525	G3526	G3527	G3528	G3529	G3530	G3531	G3532	G3533	G3534	G3535	G3536	G3537	G3538	G3539	G3540	G3541	G3542	G3543	G3544	G3545	G3546	G3547	G3548	G3549	G3550	G3551	G3552	G3553	G3554	G3555	G3556	G3557	G3558	G3559	G3560
-------	-------	-------	-------	-------	-------	-------	-------	-------	-------	-------	-------	-------	-------	-------	-------	-------	-------	-------	-------	-------	-------	-------	-------	-------	-------	-------	-------	-------	-------	-------	-------	-------	-------	-------	-------	-------	-------	-------	-------	-------	-------	-------	-------	-------	-------	-------	-------	-------	-------	-------	-------	-------	-------	-------	-------	-------	-------	-------	-------	-------	-------	-------	-------	-------	-------	-------	-------	-------	-------	-------	-------	-------	-------	-------	-------	-------	-------	-------	-------	-------	-------	-------	-------	-------	-------	-------	-------	-------	-------	-------	-------	-------	-------	-------	-------	-------	-------	-------	-------	-------	-------	-------	-------	-------	-------	-------	-------	-------	-------	-------	-------	-------	-------	-------	-------	-------	-------	-------	-------	-------	-------	-------	-------	-------	-------	-------	-------	-------	-------	-------	-------	-------	-------	-------	-------	-------	-------	-------	-------	-------	-------	-------	-------	-------	-------	-------	-------	-------	-------	-------	-------	-------	-------	-------	-------	-------	-------	-------	-------	-------	-------	-------	-------	-------	-------	-------	-------	-------	-------	-------	-------	-------	-------	-------	-------	-------	-------	-------	-------	-------	-------	-------	-------	-------	-------	-------	-------	-------	-------	-------	-------	-------	-------	-------	-------	-------	-------	-------	-------	-------	-------	-------	-------	-------	-------	-------	-------	-------	-------	-------	-------	-------	-------	-------	-------	-------	-------	-------	-------	-------	-------	-------	-------	-------	-------	-------	-------	-------	-------	-------	-------	-------	-------	-------	-------	-------	-------	-------	-------	-------	-------	-------	-------	-------	-------	-------	-------	-------	-------	-------	-------	-------	-------	-------	-------	-------	-------	-------	-------	-------	-------	-------	-------	-------	-------	-------	-------	-------	-------	-------	-------	-------	-------	-------	-------	-------	-------	-------	-------	-------	-------	-------	-------	-------

U

• Molecule 1: 26S RRNA

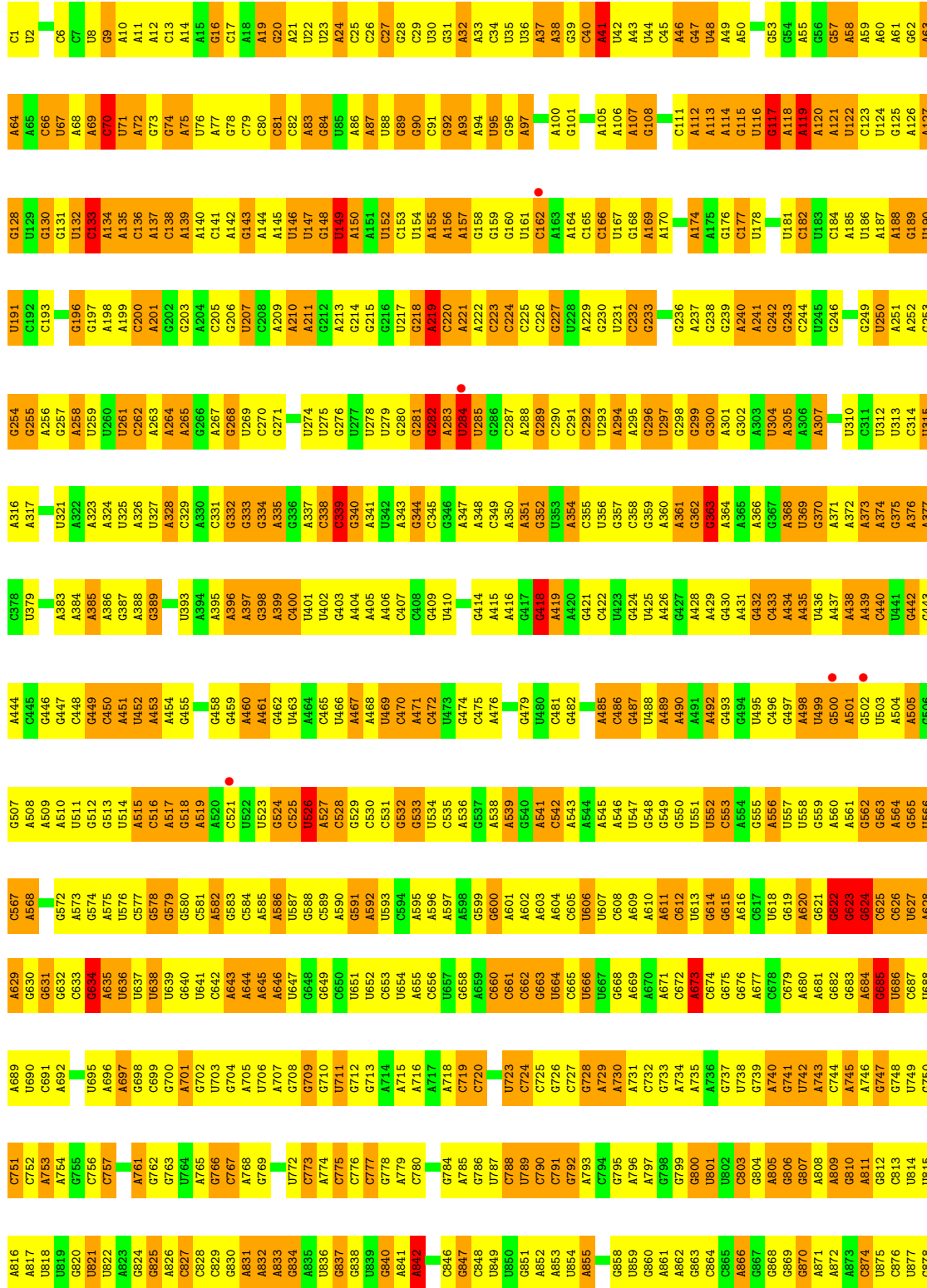
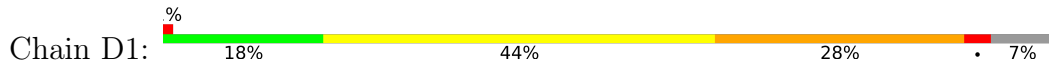



U1708	U1709	U1710	U1711	U1712	U1713	U1714	U1715	U1716	U1717	U1718	U1719	U1720	U1721	U1724	U1725	U1726	U1727	U1728	U1729	U1730	U1731	U1732	U1733	U1734	U1735	U1736	U1737	U1738	U1739	U1740	U1741	U1742	U1743	U1744	U1745	U1746	U1747	U1748	U1751	U1752	U1753	U1754	U1755	U1756	U1757	U1758	U1759	U1760	U1766	U1767	U1768	U1769	U1770	U1771	U1772						
A1838	G1639	G1640	U1641	G1642	G1643	A1644	G1645	G1646	U1647	U1648	G1649	U1650	A1651	U1652	A1653	G1654	G1655	G1656	G1657	G1658	G1659	U1660	A1661	G1662	G1663	G1664	G1665	G1666	U1667	G1668	G1669	U1670	G1671	G1672	G1673	G1674	G1675	G1676	G1677	A1680	G1681	G1682	G1683	G1684	G1685	G1686	U1691	G1692	U1693	G1694	A1695	G1696	U1697	G1698	G1699	A1700	A1701	U1702	A1703	G1704	
C1576	C1577	U1578	U1579	G1580	C1581	A1582	A1583	U1584	U1585	U1586	U1587	U1588	G1589	A1590	U1591	G1592	U1593	G1594	A1595	A1596	U1597	U1598	U1599	U1600	U1601	U1602	U1603	U1604	U1605	U1606	U1607	U1608	U1609	U1610	A1613	A1614	G1615	G1616	G1617	A1618	A1619	U1620	G1621	A1622	U1625	U1626	U1627	U1628	U1629	U1630	U1631	U1632	U1633	C1634	U1635	U1636	U1637	U1638	U1639		
U1510	G1511	G1512	A1513	U1514	A1515	U1516	U1517	U1518	U1519	U1520	U1521	U1522	C1523	U1524	U1525	U1526	U1527	U1528	C1531	U1532	G1533	U1534	A1535	A1536	U1537	U1538	U1539	U1540	U1541	U1542	U1543	U1544	U1545	U1546	U1547	U1548	C1549	U1550	U1551	U1552	U1553	U1554	U1555	U1561	U1562	U1563	U1564	C1565	U1566	U1567	U1570	U1571	U1572	U1573	U1574	U1575					
G1447	G1448	G1449	U1453	U1454	U1455	U1456	G1457	U1458	U1459	U1460	U1461	U1462	U1463	U1464	U1465	U1466	U1467	U1468	U1469	U1470	U1471	U1472	U1473	U1474	U1475	U1476	U1477	U1478	U1479	U1480	U1481	U1482	U1483	U1484	U1485	U1486	U1487	U1488	U1489	U1490	U1491	U1492	U1493	U1494	U1495	U1496	U1497	U1498	U1499	U1500	U1503	U1504	U1505	U1506	U1507	U1508	U1509				
G1384	C1385	U1386	U1387	U1388	A1328	A1329	U1332	G1333	G1334	U1335	U1336	G1337	U1338	C1339	G1340	U1341	U1342	G1343	A1344	A1345	G1346	G1347	G1348	U1349	G1350	U1351	U1352	G1353	C1354	C1355	G1356	U1357	U1358	U1359	U1360	U1361	C1362	A1363	G1364	U1365	U1366	U1367	U1368	C1369	U1370	U1371	U1372	U1373	C1374	U1375	U1376	U1377	U1378	U1379	C1380	G1381	A1382	G1383			
G	G	U	G	C	C	U	A	U	G	C	A	G	U	U	C	A	A	U	A	C	C	A	C	U	U	A	A	G	C	U	U	U	U	U	A	A	C	A	A	A	C	U	U	C	A	A	C1306	C1311	C1312	A1313	C1314	U1315	U1316	C1317	A1318	C1319					
C1200	G1201	C1202	G1203	C1204	A1205	A1206	U1207	U1208	G1209	C1210	A1211	C1212	G1213	G1214	U1215	U1216	A1217	U1218	U1219	A1220	G1221	A1222	U1223	A1224	C1225	A1226	A1227	C1228	A1229	A1230	A1231	A1232	G1233	G1234	U1235	U1236	U1237	U1238	U1239	G1240	U1241	U1242	U1243	A1244	U1245	U1246	C1247	G1248	G1249	A1250	C1251	A1252	G1253	C1254	U1255	G1256	G1257	A	C		
G1140	U1141	G1142	G1143	G1144	C1145	C1146	U1147	U1148	U1149	U1150	U1151	U1152	G1153	U1154	U1155	A1156	U1157	G1158	C1159	C1160	G1161	A1162	A1163	U1164	U1165	G1166	G1167	C1168	G1169	U1170	U1171	U1172	G1173	G1174	U1175	G1176	A1177	U1178	U1179	A1180	A1181	C1182	C1183	U1184	A1185	A1186	C1187	G1188	U1189	U1190	G1191	A1192	G1193	C1194	U1195	A1196	A1197	G1198	G1199		
U1076	U1077	A1078	A1079	U1083	G1084	G1085	U1086	A1087	U1088	A1089	A1090	G1091	C1092	U1093	C1094	C1095	G1096	G1097	A1098	G1099	U1100	U1101	U1102	A1103	C1104	C1105	C1106	U1107	U1108	A1109	U1110	G1111	A1112	U1113	C1114	U1115	C1116	U1117	G1121	U1122	C1123	G1124	A1125	A1126	U1127	G1128	C1129	A1130	G1131	U1132	G1133	U1134	U1135	C1136	U1137	A1138	A1139				
U1011	U1012	U1013	U1016	A1018	G1019	G1020	U1021	A1022	A1023	A1024	G1025	C1026	G1027	A1028	C1034	A1035	G1036	A1037	G1038	G1039	C974	G975	C1041	C1042	C1043	G1044	G1045	U1046	U1047	U1048	U1049	C1050	C1051	A1052	A1053	G1054	A1055	A1056	U1057	U1058	U1059	C1060	C1061	A1062	C1063	G1064	U1065	A1066	U1067	A1002	G1003	C1069	U1070	A1005	C1071	U1006	G1007	A1008	A1009	A1046	U1010
G879	U880	G881	G882	A883	A884	G885	C886	G889	G894	A895	U896	A897	C898	U899	C902	G903	U904	G905	A906	A907	A908	A909	U910	C911	U912	U913	U914	C915	U916	U917	U918	A919	A920	A921	G925	A926	G927	U928	G929	U930	A931	G932	G933	G934	G935	C936	G937	A938	A939	A940	G941	A942	C943	C944	U944	A945	A1009	A1048	U947		

G1773	A1905	G1906	A1973	A	U	G2157	U2289	C2354	U2416	C	U2542	U2630	U2670
C1774	G1906	G1907	U1974	U	C	G2158	A2290	C2355	C2417	U	C2543	U2631	C2671
A1775	A1907	A1908	C	A	G2159	A2291	C2356	U2418	U2419	G	U2544	A2632	U2672
G1776	A1908	A1909	C	G	U2160	A2292	C2357	A2420	A2421	U	G2545	A2633	C2673
A1777	U1840	A1910	G	G	C2161	C2226	G2358	U2422	U2423	A	A2546	G2634	A2674
G1778	A1841	A1911	C	C	A2162	A2227	G2359	U2424	A2425	A	G2547	U2635	U2677
C1779	A1842	A1912	U	U	U2163	A2228	C2360	C2425	A2426	A	U2548	U2636	A2678
U1843	U1843	U1912	A	A	A2164	G2229	U2296	U2361	U2427	C	U2549	U2637	G2679
G1781	U1844	U1913	G	G	A2165	A2230	U2297	U2362	A2428	A	U2550	U2638	U2680
C1782	U1845	A1917	C	A	U2166	A2231	A2298	A2363	A2429	C	U2551	U2639	A2681
U1783	C1846	U1918	C	A	A2167	A2232	C2299	G2364	U2428	C	A2552	U2429	A2682
A1784	A1847	U1919	A	A	U2168	A2233	G2300	G2365	U2429	U	G2553	U2430	A2683
A1785	C1848	A1920	C	C	A2169	C2240	C2301	G2366	U2431	A	G2554	U2431	A2684
C	G1849	A1921	G	G	U2170	G2241	G2302	A2367	U2432	C	U2555	U2432	A2685
C	C1850	G1922	U	U	G2171	G2242	C2303	U2368	U2433	C	U2556	U2433	A2686
C	A1851	G1923	C	A	A2172	C2243	A2304	C2369	U2434	C	U2557	U2434	A2687
U	C1852	G1924	U	U	G2173	G2244	U2305	G2370	A2435	A	U2558	U2435	G2688
A	G1853	A1924	U	U	C2110	G2245	G2306	G2371	A2436	C	U2559	U2436	U2689
A	U1854	A1925	C	A	G2111	G2246	A2307	G2372	A2437	C	U2560	U2437	U2690
A	U1855	G1926	A	A	G2112	A2247	A2308	U2375	U2438	G	U2561	U2438	A2691
G1792	C1856	U1927	U	U	A2113	G2248	U2309	A2376	U2439	U	U2562	U2439	A2692
A1793	G1857	C1928	U	U	U2114	U2249	G2310	A2377	U2440	A	G2563	U2440	A2693
G1794	C1795	U1929	U	U	A2115	A2250	A2311	G2378	C	U2564	U2441	A2694	
C1795	U1796	G1930	C	G	U2116	A2251	A2312	A2379	C	U2565	U2442	A2695	
U1796	U1858	G1931	G	A	G2117	C2252	U2313	A2380	C	U2566	U2443	A2696	
G1797	U1859	C1931	C	U	U2118	U2253	U2314	U2381	U	U2567	U2444	A2697	
U1798	C1862	A1932	A	A	G2119	A2254	A2315	A2382	U	U2568	U2445	A2698	
A1799	A1863	A1933	A	A	U2120	A2255	A2316	A2383	U	U2569	U2446	A2699	
A1800	U1864	A1934	A	A	U2121	A2256	U2317	A2384	U	U2570	U2447	A2700	
A1801	A1865	U1936	G	U	G2122	G2257	G2318	C2385	U	U2571	U2448	U2701	
A1802	A1866	G1937	U	C	U2123	A2258	A2319	U2386	U	U2572	U2449	U2702	
U1803	C1867	G1938	C	A	C2124	C2259	G2320	G2387	U	U2573	U2450	G2703	
G1804	C1868	U1941	C	A	U2125	C2260	A2321	U2388	U	U2574	U2451	A2704	
C1805	G1869	C1942	G	G	G2126	U2261	A2322	C2389	A	U2575	U2452	U2705	
G1806	C1870	G1943	U	U	A2127	U2262	U2323	U2390	U	U2576	U2453	U2706	
C1807	C1807	G1944	U	C	U2128	U2263	U2324	A2324	A	U2577	U2454	U2707	
A1808	A1808	U1944	U	U	U2129	U2264	U2325	A2325	U	U2578	U2455	U2708	
C1809	A1874	A1945	C	G	G2130	A2265	U2326	U2326	U	U2579	U2456	G2709	
A1810	G1875	A1946	G	U	U2131	A2266	U2327	U2327	U	U2580	U2457	A2710	
U1811	G1876	C1947	U	U	U2132	A2267	U2328	A2328	U	U2581	U2458	U2711	
G1812	C1880	U1948	C	U	G2133	C2268	U2329	U2329	U	U2582	U2459	U2712	
A1813	C1881	U1949	C	G	U2134	U2269	U2330	A2330	U	U2583	U2460	U2713	
U1814	C1882	C1950	C	G	A2135	G2201	C2331	U2331	U	U2584	U2461	U2714	
G1815	A1882	G1951	G	U	U2136	A2202	C2332	G2332	A	U2585	U2462	C2715	
A1816	A1883	U1952	C	A	A2137	C2203	U2333	C2333	U	U2586	U2463	A2716	
U1817	G1884	G1953	U	G	U2138	U2204	U2334	A2334	U	U2587	U2464	G2717	
C1818	G1885	A1954	U	U	A2139	C2272	U2335	U2335	U	U2588	U2465	U2718	
U1819	U1886	U1955	U	G	U2140	C2273	U2336	C2400	G	U2589	U2466	A2719	
U1820	U1886	A1956	U	U	A2141	A2274	U2337	U2403	G	U2590	U2467	G2720	
G1821	C1890	A1957	U	G	G2142	A2275	C2340	G2404	C	U2591	U2468	G2721	
U1822	A1891	G1958	A	C	A2143	A2276	U2341	U2405	U	U2592	U2469	A2722	
A1823	G1892	C	C	A	U2144	U2277	U2342	U2406	A	U2593	U2470	A2723	
A1824	U1895	G1964	A	A	A2145	C2278	A2343	U2407	C	U2594	U2471	U2724	
A1825	C1896	C1965	A	A	G2146	G2279	U2344	A2408	C	U2595	U2472	A2725	
U1828	U1897	U1966	U	C	U2147	U2280	A2345	A2409	A	U2596	U2473	C2726	
U1829	U1897	C1967	A	C	U2148	G2281	C2346	U2410	A	U2597	U2474	A2727	
C1901	C1901	U1968	U	A	U2149	C2282	C2347	U2411	U	U2598	U2475	A2728	
G1832	A1902	G1969	A	A	U2150	U2284	G2350	U2412	G	U2599	U2476	C2730	
A1833	A1903	A1970	C	C	A2151	C2285	A2351	G2413	U	U2600	U2477	C2731	
U1904	G1972	G1972	G	A	G2156	A2286	C2352	U2414	U	U2601	U2478	G2732	
							C2353	C2415	C	U2602	U2479	C2733	

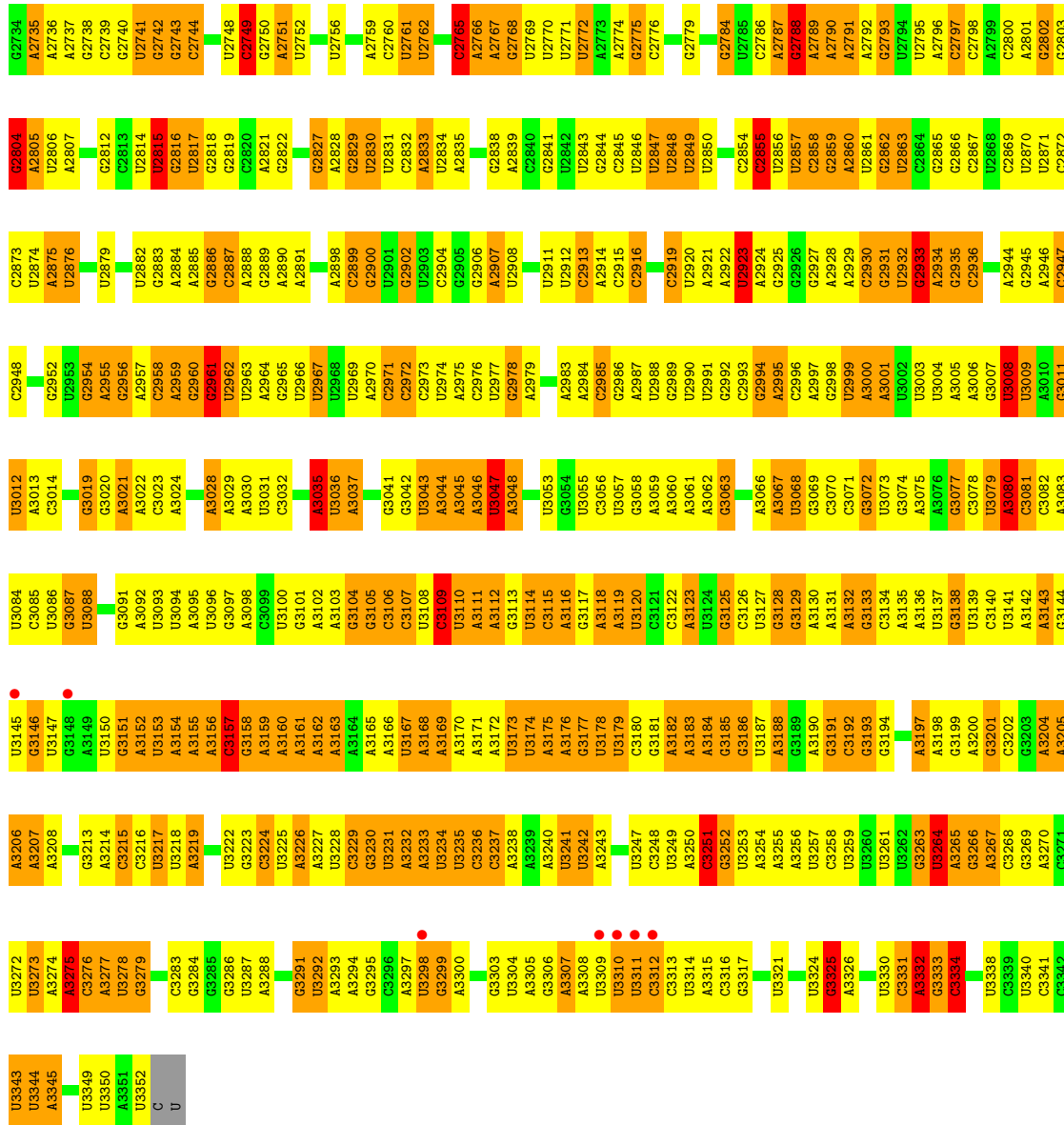

• Molecule 1: 26S RRNA

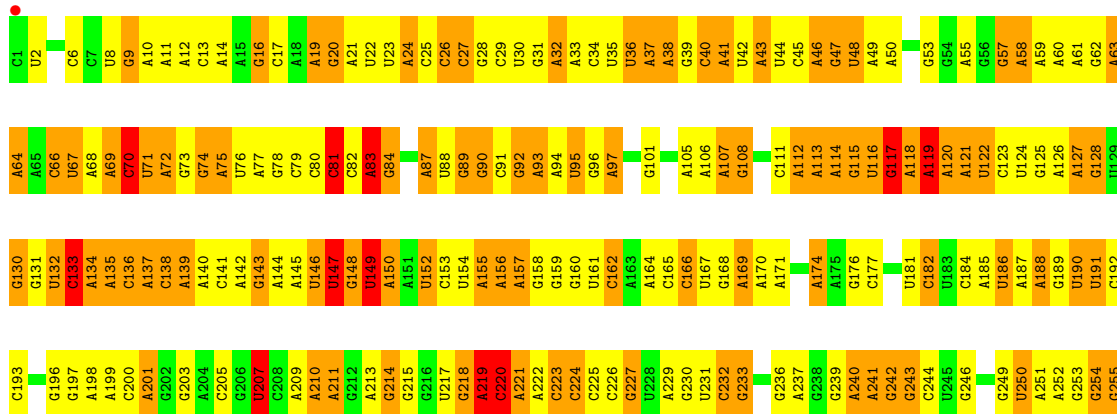
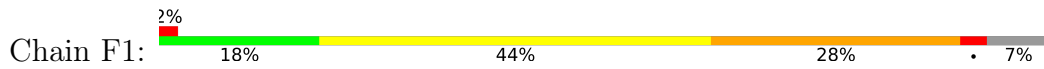

C1159	G1096	U1034	C829	G762	G700	U636	U576	U514	G447	A383	C320	A256
A1160	G1097	A1035	G830	A765	A701	U637	C577	A615	C446	A384	C320	C257
A1161	A1098	G1036	A831	A766	G702	U638	G578	C516	C449	A385	A323	A258
A1162	G1099	A1037	A832	G766	U703	U639	G579	A517	C450	A386	A324	U261
A1163	U1100	G1038	A833	C767	A704	G640	G580	G518	A451	A387	A325	C262
C1164	U1101	A1039	G834	A768	G705	U641	C581	A519	U452	A388	A326	A263
U1165	U1102	A908	A835	G769	U706	C642	A582	A520	A453	A389	U327	A264
U1166	A1040	A909	U836	A643	A707	A643	G583	C521	A454	A390	A328	A285
G1167	U1042	G911	G837	U772	G708	A644	C584	U522	C455	A391	A329	G286
C1168	G1043	G912	G838	C773	A709	A645	A585	U523	G458	A392	C329	G287
G1169	U1044	U913	U839	A774	G710	A646	A586	G524	A459	A393	A330	U266
A1170	G1045	U914	G840	C775	U711	U647	U587	C525	A460	A394	C331	G268
U1171	A841	A915	A841	C776	G712	U647	G588	U526	A461	A395	G332	U269
G1172	G916	C916	A842	C777	G713	U651	C589	A527	A462	A396	C333	C270
A1173	U917	U917	G778	G778	A714	U652	A590	C528	C462	A397	G334	G271
G1174	C846	C918	G778	G778	A715	U653	A591	C529	U463	A398	G335	G272
G1175	G847	A919	A716	G784	A716	C653	G591	C530	A464	A399	A336	G273
G1176	C848	A920	A716	A785	A717	U655	A592	C531	C465	A400	G337	U274
U1177	C849	A921	A718	G786	A718	C656	G593	C532	U465	U401	C338	U275
U1178	U850	U922	A719	U857	C719	U658	A595	G533	A467	U402	C339	G276
G1179	G851	G925	C720	G788	C720	U659	A596	U534	U468	U403	G340	U277
A1180	A852	A926	G721	U789	G721	A659	A597	C535	U469	A404	A341	U278
A1181	A853	G927	G722	C790	G722	C660	A598	C536	C470	A405	U342	U279
C1182	U854	G928	U723	C791	U723	C661	G599	G537	A471	A406	A343	G280
C1183	A855	U928	G724	G792	C724	C662	G600	A538	C472	C407	G344	G281
U1184	A929	G929	C725	A793	C725	G663	A601	A539	U473	G488	C345	G282
A1185	G858	U930	G726	C794	G726	U664	A602	G540	C474	G409	G346	A283
A1186	U859	U931	G727	G795	C727	A603	A603	G541	U485	U419	A347	U284
G1187	G860	G932	A728	A796	G728	U666	A604	C542	C486	A354	A348	U285
G1188	A861	A933	A729	A797	G729	U667	C505	A543	C487	A415	C349	G286
U1189	A862	G934	A730	G804	A730	G668	U606	A544	U488	A416	A350	C287
U1190	G863	G935	A731	A805	A731	U669	U607	A545	C481	G417	A351	A288
G1191	C936	C936	C732	G800	C732	U670	C608	A546	G482	G418	G352	G289
A1192	U864	G937	G733	U801	G733	C672	A609	U547	U485	A419	U353	C290
G1193	A865	A938	A734	U802	A734	A673	A610	G548	C486	A354	A354	C291
A1194	G867	A939	A735	C803	A735	C674	A611	G549	U487	C422	C355	C292
U1195	G870	A940	A736	G804	A736	G675	G550	G550	U488	H423	U356	U293
A1196	G871	G841	G737	A805	G737	G676	U613	U551	A489	G424	G357	A294
A1197	A871	A942	U738	G806	U738	C679	G614	U552	U490	U425	C358	A295
G1198	A872	C943	G739	G807	G739	U680	G615	C553	A491	U426	G359	G296
G1199	A873	U944	A740	A808	A740	A680	A616	A554	G427	A426	A360	U297
C1200	C874	A945	G741	A809	G741	A681	C617	G555	C493	G427	A361	U298
G1201	U875	A946	U742	G810	U742	G682	U618	A556	A429	A429	G362	G299
C1202	C876	U947	A743	A811	A743	G683	G619	U557	G497	G430	G363	G300
C1203	U877	C948	C744	G812	C744	A684	A620	U558	U498	A364	A364	A301
C1204	U878	C948	A745	C813	A745	G685	G621	G559	U499	G432	A365	G302
A1205	U880	U957	A746	U814	A746	U686	G622	A560	G500	C433	A366	A303
A1206	G881	A958	G747	U815	G747	C687	G623	A561	A501	C433	G367	U304
A1207	G882	G959	G748	A816	G748	U688	G624	G562	G502	A368	A368	A305
U1208	A883	U960	U749	A817	U749	A689	C625	G563	U503	A435	U369	A306
G1209	A884	A961	G750	U818	G750	U690	C626	A564	A504	U436	G370	A307
C1210	G885	G962	U751	U819	U751	U691	U627	G565	A505	A437	A371	U310
A1211	C886	C963	C752	G820	C752	A692	A628	U566	G506	A438	A372	U311
C1212	G887	U964	A753	U821	A753	A693	A629	C567	G507	A439	A373	C311
G1213	A888	G965	U754	U822	G754	G630	G630	A568	U441	A441	A374	U312
C1214	G889	G966	A755	U823	A755	U694	G631	G631	A508	G442	A375	U313
U1215	U886	U967	C756	G825	C756	A696	G632	G572	A510	G443	A376	C314
C1216	A887	U968	C757	A826	C757	A697	C633	A573	U511	A444	A377	U315
A1217	C888	C969	U758	G827	U758	G698	G634	G574	G512	C378	A378	A316
U1218	U889	C970	A761	C828	A761	C699	A635	A575	G513	G446	U379	A317

A	A2100	G2097	U	A1933	A1863	A1793	A1728	A1662	U1600	G1583	G1470	C1403	U1342	U	A1231	G1233	A1231	C1219
A	A1864	G1794	A	U1729	C1663	U1601	G1584	C1664	U1602	G1583	U1471	G1404	G1343	C	A1220	G1236	A1220	A1220
G	A1865	U1798	G	G1731	C1665	U1603	U1537	C1666	U1604	U1537	G1472	U1406	G1344	C	A1222	U1237	A1222	A1222
G	A1866	C1799	C	C1732	C1667	U1605	G1539	A1666	C1604	U1539	U1473	A1407	A1345	C	A1223	U1238	A1223	A1223
A	C1868	A1800	A	C1733	A1667	G1605	U1540	A1668	C1605	G1540	G1475	U1408	G1348	U	A1224	U1239	A1224	A1224
A	G1869	G1801	A	A1734	A1668	U1606	U1541	A1669	U1606	U1541	G1476	C1409	G1349	A	C1225	U1240	C1225	C1225
G	C1870	U1802	G	U1735	G1669	U1607	G1542	G1670	U1607	G1542	C1477	U1410	G1350	A	A1226	G1239	A1226	A1226
U	C1873	G1803	U	G1736	A1670	G1608	C1541	C1671	G1608	C1541	U1478	U1411	G1351	G	A1227	U1241	A1227	A1227
U	A1874	G1804	U	A1737	C1672	U1609	A1543	C1673	U1609	A1543	A1479	U1412	G1352	G	A1228	U1242	A1228	A1228
U	G1875	C1805	U	A1738	C1674	C1610	U1544	C1675	C1610	U1544	A1480	U1413	G1353	G	A1229	U1243	A1229	A1229
C	G1875	G1806	C	A1739	C1675	C1611	G1545	C1676	U1606	G1545	U1481	U1414	G1354	A	A1230	U1244	A1230	A1230
G	U1807	C1807	G	U1740	G1676	U1620	G1546	G1677	U1620	G1546	U1482	U1415	G1355	U	A1231	U1245	A1231	A1231
U	A1808	U1807	U	U1741	G1677	A1622	G1547	U1677	A1622	G1547	U1483	U1416	G1356	G	A1232	U1246	A1232	A1232
U	C1881	A1809	U	G1742	A1680	U1621	U1548	A1681	U1621	U1548	U1484	U1417	G1357	U	A1233	U1247	A1233	A1233
G	A1882	C1810	G	G1743	A1680	G1690	U1549	C1681	U1626	U1549	U1485	G1418	G1358	U	A1234	U1248	A1234	A1234
G	A1883	U1811	U	A1744	C1681	U1691	A1550	C1682	A1627	A1550	U1486	G1419	G1359	U	A1235	U1249	A1235	A1235
U	G1884	C1812	U	U1745	G1682	U1692	U1551	C1683	U1629	U1551	U1487	U1423	G1360	U	A1236	U1250	A1236	A1236
C	G1885	A1813	C	U1746	U1683	U1693	U1552	U1684	U1629	U1552	U1488	U1424	G1361	A	A1237	U1251	A1237	A1237
U	A1954	U1814	U	A1747	C1684	U1694	C1583	C1685	U1630	C1583	U1489	U1425	C1362	C	A1238	U1252	A1238	A1238
U	C1890	G1815	U	U1748	A1685	G1621	G1554	U1686	A1622	G1554	U1490	U1426	A1363	A	A1239	U1253	A1239	A1239
U	A1891	A1816	U	A1751	U1686	A1622	U1555	A1687	A1622	U1555	U1491	U1427	A1364	A	U1241	U1254	U1241	U1241
U	G1892	C1817	U	A1752	G1687	A1622	U1556	U1688	A1622	U1556	U1492	U1428	G1365	C	U1242	U1255	U1242	U1242
U	U1895	C1818	U	A1753	U1688	U1622	U1557	U1689	A1622	U1557	U1493	U1429	G1366	A	U1243	U1256	U1243	U1243
U	C1896	U1820	U	G1754	G1689	U1626	G1562	U1690	U1626	G1562	U1494	U1430	A1367	C	A1244	U1257	A1244	A1244
C	U1897	U1821	C	U1755	U1691	A1627	C1564	U1692	A1627	C1564	U1495	U1431	U1368	A	U1245	U1258	U1245	U1245
A	G1898	G1822	A	U1756	U1692	U1692	A1566	U1693	U1629	A1566	U1496	G1432	C1369	C	U1246	U1259	U1246	U1246
A	U1899	A1823	A	A1757	U1693	U1693	A1567	U1694	U1629	A1567	U1497	U1433	G1371	C	C1247	U1260	C1247	C1247
U	C1901	A1824	U	U1758	C1694	U1694	U1570	U1695	U1630	U1570	U1498	U1434	G1372	U	A1248	U1261	A1248	A1248
U	C1902	U1824	U	C1759	A1696	U1632	U1571	U1696	U1632	U1571	U1499	U1435	A1372	C	A1249	U1262	A1249	A1249
C	A1903	G1828	C	G1760	U1697	C1633	A1572	U1697	C1633	A1572	U1500	U1436	G1373	C	A1250	U1263	A1250	A1250
C	U1904	U1829	C	U1761	G1698	C1634	A1573	U1698	C1634	A1573	A1503	U1437	C1374	C	C1251	U1264	C1251	C1251
G	A1905	G1830	G	U1762	G1699	U1635	A1574	U1699	U1635	A1574	U1504	U1438	A1375	C	A1252	U1265	A1252	A1252
G	U1906	G1831	G	G1763	A1700	C1636	C1574	U1700	C1636	C1574	C1504	U1439	A1376	C	A1253	U1266	A1253	A1253
U	A1907	G1832	C	G1764	A1701	U1637	U1575	U1701	U1637	U1575	C1505	U1440	A1377	U	A1254	U1267	A1254	A1254
A	A1908	G1833	C	U1765	G1702	A1638	C1576	U1702	A1638	C1576	G1506	U1441	A1378	C	A1255	U1268	A1255	A1255
A	C1909	G1834	A	A1770	A1703	G1639	C1577	U1703	G1639	C1577	U1507	U1442	G1379	C	A1256	U1269	A1256	A1256
G	U1910	A1839	G	U1771	G1704	C1640	U1578	U1704	C1640	U1578	U1508	G1445	C1380	A	G1257	U1270	G1257	G1257
A	A1911	U1840	A	G1772	U1705	U1641	U1579	U1705	U1641	U1579	A1582	G1446	G1381	C	A	U1271	A	A
U	G1912	A1841	U	G1773	U1706	G1642	U1580	U1706	G1642	U1580	U1510	A1447	A1382	C	A	U1272	A	A
U	A1913	A1842	U	C1774	A1707	G1643	C1581	U1707	G1643	C1581	G1511	G1448	G1383	G	A	U1273	A	A
C	A1917	U1843	C	G1775	U1710	A1644	A1582	U1710	A1644	A1582	G1512	C1449	G1384	C	A	U1274	A	A
A	U1918	U1844	U	G1776	U1711	C1645	A1583	U1711	C1645	A1583	A1513	U1453	G1385	U	A	U1275	A	A
A	A1919	U1845	G	G1777	U1712	G1646	U1584	U1712	G1646	U1584	A1516	A1454	U1386	C	A	U1276	A	A
A	A1920	C1846	A	G1778	U1713	U1647	C1585	U1713	U1647	C1585	G1517	G1455	U1387	C	A	U1277	A	A
C	G1921	A1847	C	A1779	U1714	G1648	C1586	U1714	G1648	C1586	G1518	G1456	U1388	C	A	U1278	A	A
C	A1922	C1848	C	U1781	U1715	U1649	A1587	U1715	U1649	A1587	G1519	U1457	G1389	U	A	U1279	A	A
C	G1923	U1852	C	U1782	U1716	G1650	A1588	U1716	G1650	A1588	U1520	C1458	A1390	C	A	U1280	A	A
A	U1924	A1853	A	U1783	U1717	A1651	G1589	U1717	A1651	G1589	C1521	A1459	A1391	U	A	U1281	A	A
U	A1925	G1853	U	C1784	U1718	U1652	A1590	U1718	U1652	A1590	C1522	G1460	G1392	G	A	U1282	A	A
G	U1926	U1854	G	A1785	A1719	G1653	A1591	U1719	G1653	A1591	C1523	A1461	A1393	A	A	U1283	A	A
C	U1927	U1855	C	C	A1720	G1654	U1592	U1720	G1654	U1592	A1524	U1462	G1394	A	A	U1284	A	A
A	C1928	G1856	A	C	A1721	A1655	A1593	U1721	A1655	A1593	U1525	C1463	A1395	G	A	U1285	A	A
U	A1929	C1857	U	C	U1724	G1656	U1594	U1724	G1656	U1594	G1656	U1464	G1397	U	A	U1286	A	A
U	G1930	U1858	U	U	A1725	C1657	A1595	U1725	C1657	A1595	A1527	U1465	U1398	U	A	U1287	A	A
U	A1931	C1861	U	A	A1726	G1658	U1596	U1726	G1658	U1596	G1528	G1466	A1399	A	A	U1288	A	A
G	U1932	C1862	G	A	C1726	U1659	U1597	U1727	U1659	U1597	C1531	U1467	G1400	G	A	U1289	A	A
C	A1933	C1863	C	G1792	U1727	A1661	G1599	U1727	A1661	G1599	A1532	G1469	G1402	C	A	U1290	A	A



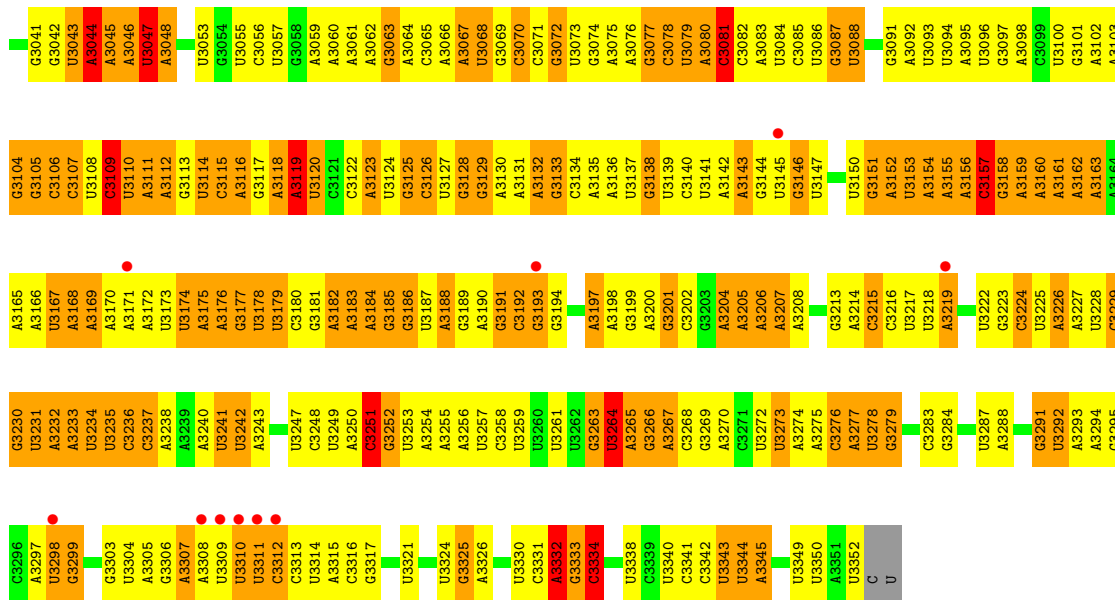

• Molecule 1: 26S RRNA

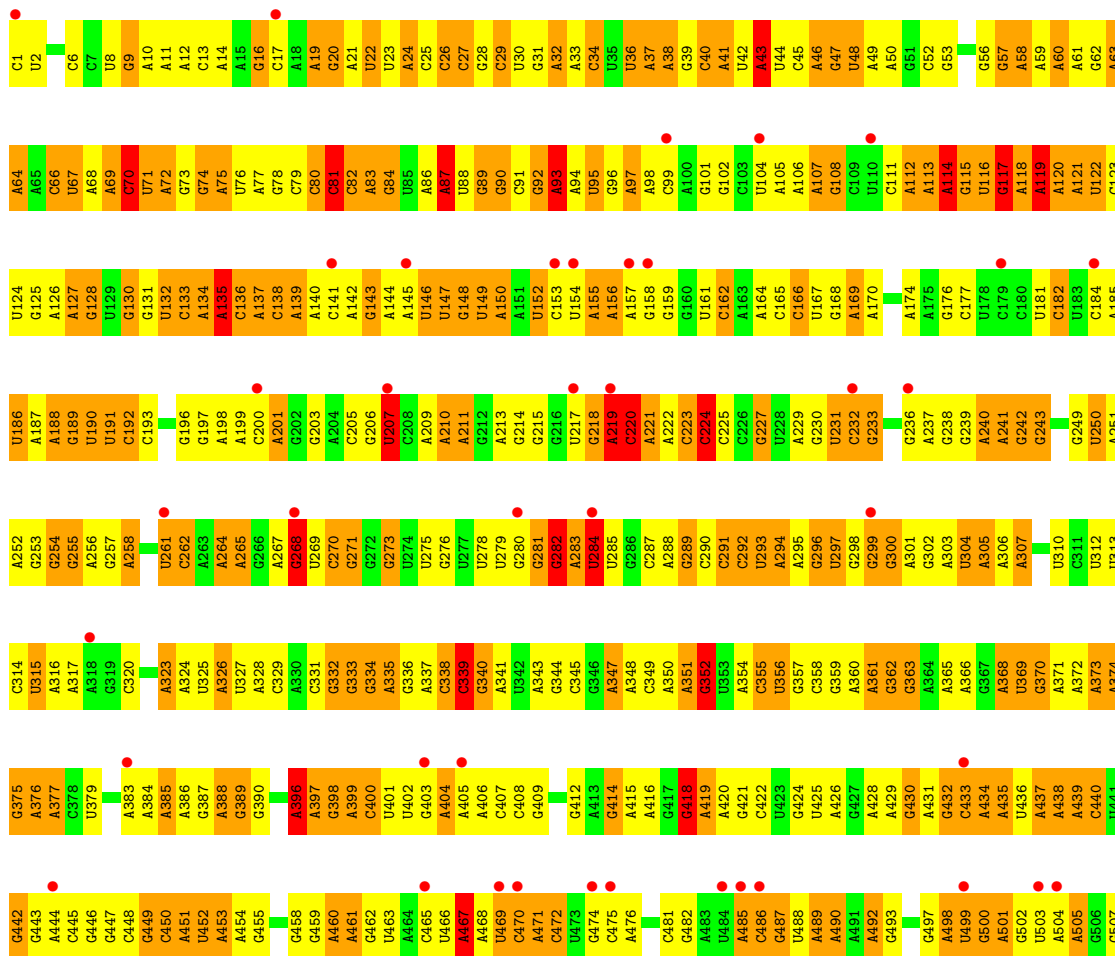
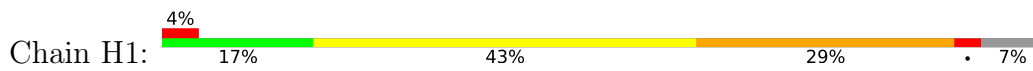





C2222	A2154	G1906	C1838	A1777	C1714	A1644	C1581	C1449	U1386
A2223	C2155	A1907	A1839	G1778	U1715	C1645	A1582	A1516	U1387
A2227	G2156	A1908	U1840	C1779	A1716	U1646	A1583	G1517	U1388
G2228	A2157	C1909	A1841	A1780	U1717	U1647	U1584	G1455	U1389
G2229	C2097	A1910	A1842	G1781	U1718	G1648	C1585	U1456	U1390
C2230	U2100	U1911	U1843	C1782	U1719	U1650	C1586	G1457	U1391
A2238	G2101	U1912	U1844	U1783	U1720	A1651	A1587	C1458	G1392
A2239	A2102	G1913	C1845	C1784	A1721	U1652	A1588	G1459	A1393
C2240	A2103	U1914	A1846	A1785	A1722	A1653	G1589	A1460	G1394
G2241	C2104	C1915	C1847	C	A1723	A1654	A1590	A1461	U1395
G2242	U2105	A1916	C1848	C	A1724	A1655	A1591	U1462	A1396
C2243	G2106	A1917	A1852	U	U1725	G1656	A1592	G1463	G1397
G2244	A2107	U1918	G1853	A	C1726	C1657	C1594	U1464	G1398
G2245	A2108	A1919	U1854	A	U1727	G1658	U1595	U1465	A1399
G2246	G2109	G1920	U1855	A	A1728	G1659	U1596	G1466	G1400
G2247	C2110	U1921	G1856	G1792	U1729	U1660	A1532	G1467	G1401
A2248	G2111	G1922	G1857	A1793	U1730	A1661	C1598	U1468	A1402
A2249	C2112	A1923	U1858	G1794	G1731	A1662	C1599	G1470	G1403
A2250	A2113	U1924	U1859	C1795	C1732	C1663	U1601	U1471	U1404
A2251	C2114	A1925	C1861	U1796	C1733	G1664	U1602	A1472	U1405
A2252	A2115	G1926	C1862	G1797	A1734	C1665	U1603	A1475	U1407
A2253	G2116	U1927	A1863	C1798	U1735	A1666	U1604	A1476	U1408
A2254	A2117	C1928	C1864	U1799	G1736	A1667	C1604	G1476	A1409
A2255	G2118	G1929	U1864	A1800	G1737	A1668	G1605	G1477	G1410
U2255	A2119	A1930	A1865	G1801	A1738	G1669	U1606	A1478	U1411
G2256	G2120	C1931	A1866	U1802	U1739	A1670	U1607	U1479	U1412
U2257	A2121	A1932	C1868	U1803	A1740	G1671	G1608	A1480	G1413
U2258	U2122	G1933	G1869	G1804	U1741	C1672	U1609	A1481	A1414
U2259	C2123	U1934	C1870	C1805	G1742	A1673	C1610	U1482	C1415
C2260	A2124	U1935	A1871	G1806	G1743	G1674	C1611	U1483	U1416
U2261	G2125	G1936	U1872	A1808	A1744	G1675	G1612	U1484	A1417
C2262	G2126	U1937	C1873	C1809	U1745	A1680	A1614	U1485	G1418
U2263	A2127	C1938	A1874	U1810	U1746	G1681	G1615	U1486	A1419
U2264	C2128	C1941	G1875	U1811	A1747	G1682	G1616	A1487	U1423
A2265	U2129	G1942	U1876	G1812	U1748	U1683	G1617	U1488	A1424
A2266	G2130	U1943	C1877	A1813	U1749	A1684	A1618	U1489	U1425
G2267	U2131	U1944	C1880	U1814	A1751	A1685	U1620	G1490	U1426
G2268	U2132	A1945	C1881	G1815	G1752	G1686	G1621	A1491	G1427
U2269	U2133	A1946	A1882	U1816	A1753	U1691	A1622	A1492	G1428
A2270	A2134	U1947	A1883	A1817	G1754	G1692	G1623	A1493	G1429
G2271	A2135	C1948	G1884	C1818	A1755	U1693	U1625	G1495	U1430
C2272	U2136	U1949	G1885	U1819	U1756	C1694	U1626	U1496	U1431
A2203	C1950	C1950	U1886	U1820	A1757	A1695	A1627	U1497	G1432
U2204	G1951	G1952	C1890	U1821	U1758	A1696	A1628	A1500	G1433
A2208	A2139	G1953	A1891	G1822	C1759	A1697	U1629	G1434	C1435
A2209	U2141	U1954	G1892	A1823	G1760	U1698	A1630	A1503	C1436
G2210	C2142	U1955	C1893	A1824	G1761	U1699	U1631	C1504	U1437
U2211	A2143	A1956	U1894	U1825	U1762	A1700	U1632	C1505	A1438
U2212	A2144	A1957	U1895	A1826	A1763	A1701	C1636	G1506	U1439
G2213	A2145	G1958	C1896	U1827	G1764	G1702	A1637	A1507	A1440
A2214	G2146	U1959	U1897	C1828	U1765	A1703	A1638	A1508	U1441
C2215	C2147	A1964	G1898	U1829	U1766	G1704	G1639	G1509	G1445
G2216	A2148	C1965	C1901	G1830	U1767	U1708	C1640	U1510	C1446
G2217	U2149	U1966	C1902	G1831	G1768	C1709	U1641	G1511	A1447
A2218	U2150	C1967	A1903	G1832	U1769	U1710	G1642	A1512	G1448
U2219	G2151	U1971	U1904	G1833	C1774	U1711	G1643	A1513	
U2220	U2152	C1972	A1905	A1837	G1775				
U2221	G2153				G1776				

A2290 A2291 U2292 U2293 A2294 G2295	U2416 C2417 U2418 A2419 G2420 U2421 C2422 U2423 A2424 C2425 A2426 U2427 G2428 A2429 C2430 U2431 A2432 C2433 U2434 A2435 G2436 A2437 C2438 U2439 A2440	C2353 C2354 C2355 A2356 C2357 A2358 C2359 C2360 U2361 A2362 C2363 U2364 A2365 C2366 U2367 A2368 C2369 U2370 A2371 C2372	U2542 C2543 U2544 A2545 C2546 U2547 A2548 U2549 C2550 A2551 C2552 U2553 A2554 C2555 U2556 A2557 C2558 U2559 A2560 C2561 U2562 A2563 C2564 U2565 A2566 C2567 U2568 A2569 C2570 U2571 A2572 C2573 U2574 A2575 C2576 U2577 A2578 C2579 U2580 A2581 C2582 U2583 A2584 C2585 U2586 A2587 C2588 U2589 A2590 C2591 U2592 A2593 C2594 U2594 A2595 C2596 U2597 A2598 C2599 U2600 A2601 C2602 U2603	U2604 C2605 U2606 A2607 C2608 U2609 A2610 C2611 U2612 A2613 C2614 U2615 A2616 C2617 U2618 A2619 C2620 U2621 A2622 C2623 U2624 A2625 C2626 U2627 A2628 C2629 U2630 A2631 C2632 U2633 A2634 C2635 U2636 A2637 C2638 U2639 A2640 C2641 U2642 A2643 C2644 U2645 A2646 C2647 U2648 A2649 C2650 U2651 A2652 C2653 U2654 A2655 C2656 U2657 A2658 C2659 U2660 A2661 C2662 U2663 A2664 C2665 U2666	U2666 A2667 C2668 U2669 A2670 C2671 U2672 A2673 C2674 U2675 A2676 C2677 U2678 A2679 C2680 U2681 A2682 C2683 U2684 A2685 C2686 U2687 A2688 C2689 U2690 A2691 C2692 U2693 A2694 C2695 U2696 A2697 C2698 U2699 A2700 C2701 U2702 A2703 C2704 U2705 A2706 C2707 U2708 A2709 C2710 U2711 A2712 C2713 U2714 A2715 C2716 U2717 A2718 C2719 U2720 A2721 C2722 U2723 A2724 C2725 U2726 A2727 C2728 U2729 A2730 C2731	G2732 C2733 U2734 A2735 C2736 U2737 A2738 C2739 U2740 A2741 C2742 U2743 A2744 C2745 U2746 A2747 C2748 U2749 A2750 C2751 U2752 A2753 C2754 U2755 A2756 C2757 U2758 A2759 C2760 U2761 A2762 C2763 U2764 A2765 C2766 U2767 A2768 C2769 U2770 A2771 C2772 U2773 A2774 C2775 U2776 A2777 C2778 U2779 A2780 C2781 U2782 A2783 C2784 U2785 A2786 C2787 U2788 A2789 C2790 U2791 A2792 C2793 U2794 A2795	A2796 C2797 U2798 A2799 C2800 U2801 A2802 C2803 U2804 A2805 C2806 U2807 A2808 C2809 U2810 A2811 C2812 U2813 A2814 C2815 U2816 A2817 C2818 U2819 A2820 C2821 U2822 A2823 C2824 U2825 A2826 C2827 U2828 A2829 C2829 U2830 A2831 C2832 U2833 A2834 C2835 U2836 A2837 C2838 U2839 A2840 C2841 U2842 A2843 C2844 U2845 A2846 C2847 U2848 A2849 C2850 U2851 A2852 C2853 U2854 A2855 C2856 U2857 A2858 C2859 U2860 A2861 C2862 U2863 A2864 C2865 U2866 A2867 C2868 U2869 A2870 C2871 U2872 A2873 C2874 U2875 A2876 C2877 U2878 A2879 C2880 U2881 A2882 C2883 U2884 A2885 C2886 U2887 A2888 C2889 U2890 A2891 C2892 U2893 A2894 C2895 U2896 A2897 C2898 U2899 A2900 C2901 U2902 A2903 C2904 U2905 A2906 C2907 U2908 A2909 C2910 U2911 A2912 C2913 U2914 A2915 C2916 U2917 A2918 C2919 U2920 A2921 C2922 U2923 A2924 C2925 U2926 A2927 C2928 U2929 A2929 C2930 U2931 A2932 C2933	A2934 G2935 C2936 U2937 A2938 C2939 U2940 A2941 C2942 U2943 A2944 C2945 U2946 A2947 C2948 U2949 A2950 C2951 U2952 A2953 C2954 U2955 A2956 C2957 U2958 A2959 C2960 U2961 A2962 C2963 U2964 A2965 C2966 U2967 A2968 C2969 U2970 A2971 C2972 U2973 A2974 C2975 U2976 A2977 C2978 U2979 A2980 C2981 U2982 A2983 C2984 U2985 A2986 C2987 U2988 A2989 C2990 U2991 A2992 C2993 U2994 A2995 C2996 U2997 A2998 C2999 U3000	G2998 U2999 A3000 C3001 U3002 A3003 C3004 U3005 A3006 C3007 U3008 A3009 C3010 U3011 A3012 C3013 U3014 A3015 C3016 U3017 A3018 C3019 U3020 A3021 C3022 U3023 A3024 C3025 U3026 A3027 C3028 U3029 A3030 C3031 U3032 A3033 C3034 U3035 A3036 C3037 U3038 A3039 C3040 U3041 A3042 C3043 U3044 A3045 C3046 U3047 A3048 C3049 U3050 A3051 C3052 U3053 A3054 C3055 U3056 A3057 C3058 A3059 U3060 A3061 C3062 U3063 A3064 C3065 U3066 A3067 C3068 U3069 A3070 C3071 U3072 A3073 C3074 U3075 A3076 C3077 U3078 A3079 C3080 U3081 A3082 C3083 U3084 A3085 C3086 U3087 A3088 C3089 U3090 A3091 C3092 U3093 A3094 C3095 U3096 A3097 C3098 U3099 A3100 C3101 U3102 A3103 C3104 U3105 A3106 C3107 U3108 A3109 C3110 U3111 A3112 C3113 U3114 A3115 C3116 U3117 A3118 C3119 U3120 A3121 C3122 U3123 A3124 C3125 U3126 A3127 C3128 U3129 A3130	A3130 A3131 G3132 A3133 C3134 A3135 U3136 A3137 G3138 U3139 A3140 C3141 U3142 A3143 G3144 U3145 A3146 C3147 U3148 G3149 U3150 G3151 A3152 C3153 U3154 A3155 C3156 G3157 A3158 U3159 A3160 C3161 A3162 G3163 U3164 A3165 C3166 U3167 A3168 C3169 A3170 U3171 A3172 C3173 U3174 A3175 C3176 U3177 A3178 C3179 U3180 A3181 C3182 U3183 A3184 C3185 U3186 A3187 C3188 U3189 A3190
--	---	--	---	---	--	--	--	---	---	---

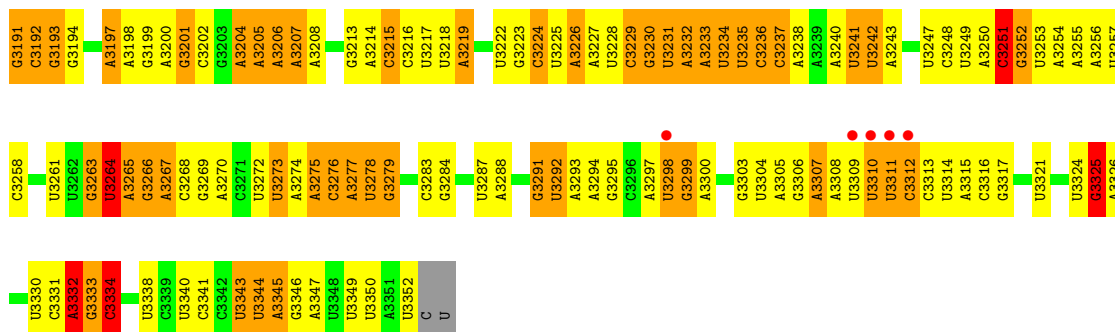

- Molecule 2: RIBOSOMAL PROTEIN L37

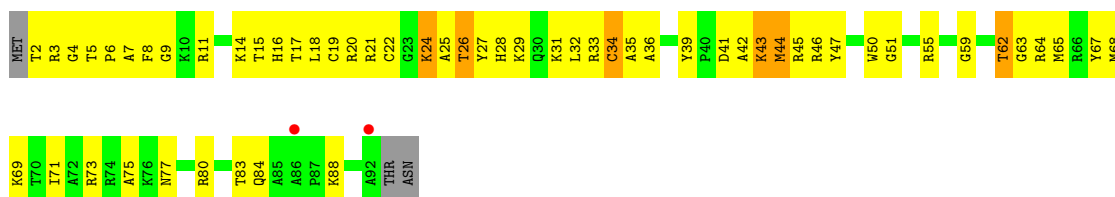

- Molecule 2: RIBOSOMAL PROTEIN L37

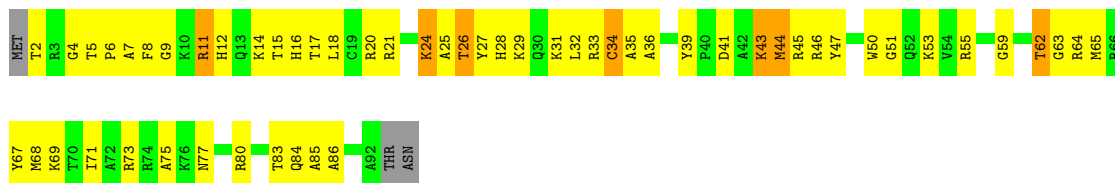
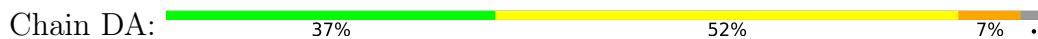

- Molecule 2: RIBOSOMAL PROTEIN L37

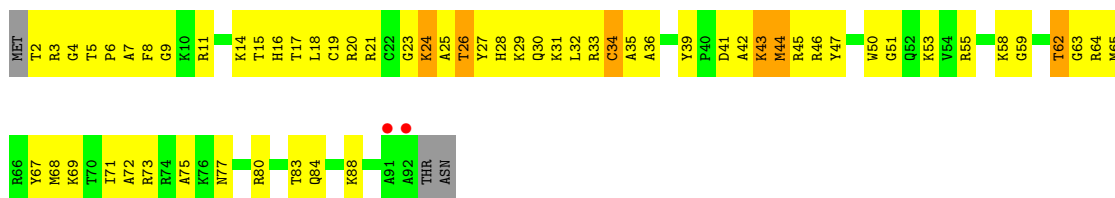

- Molecule 2: RIBOSOMAL PROTEIN L37



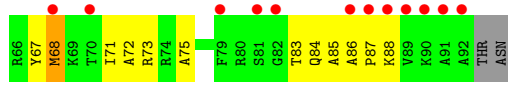

• Molecule 3: RPL39



• Molecule 3: RPL39

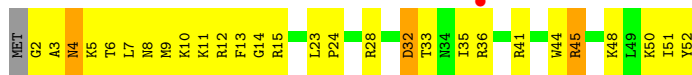

• Molecule 3: RPL39



• Molecule 3: RPL39



• Molecule 4: 60S RIBOSOMAL PROTEIN L36A

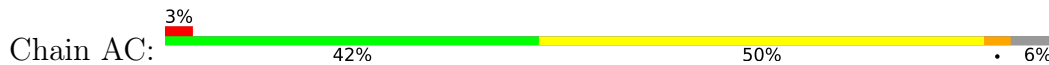

• Molecule 4: 60S RIBOSOMAL PROTEIN L36A





● Molecule 4: 60S RIBOSOMAL PROTEIN L36A

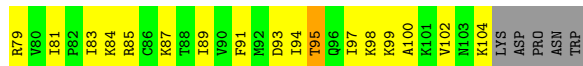

● Molecule 4: 60S RIBOSOMAL PROTEIN L36A

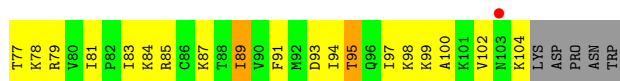
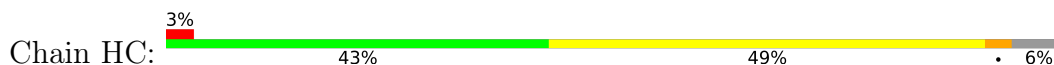

● Molecule 5: RPL6

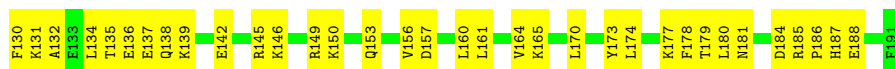
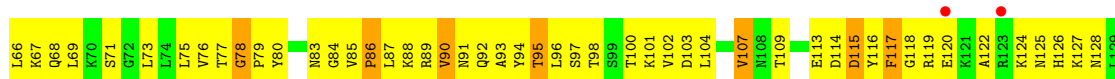
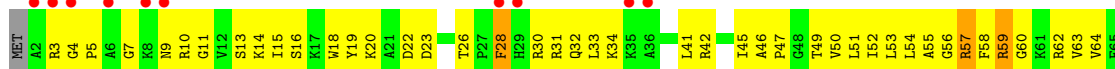

● Molecule 5: RPL6

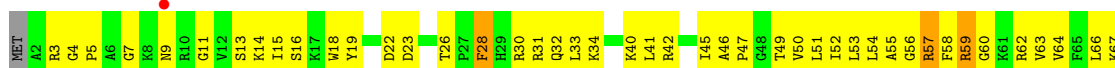



• Molecule 5: RPL6

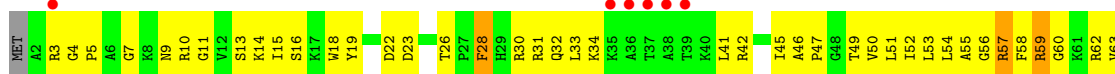

• Molecule 5: RPL6

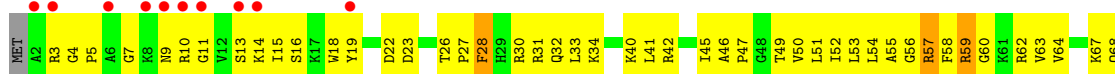

• Molecule 6: RPL14



• Molecule 6: RPL14





• Molecule 6: RPL14

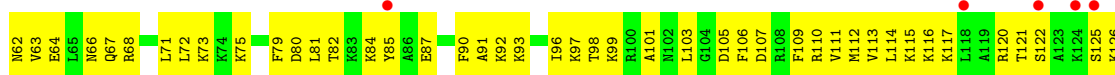

• Molecule 6: RPL14

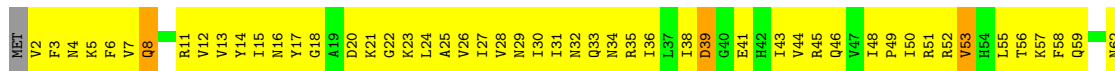
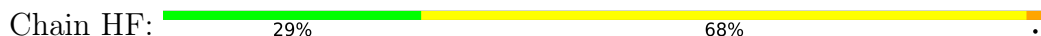

• Molecule 7: RPL30

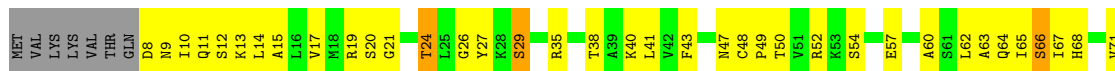

• Molecule 7: RPL30

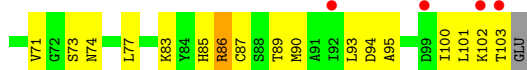
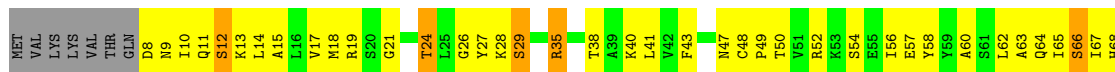

• Molecule 7: RPL30



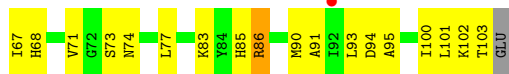
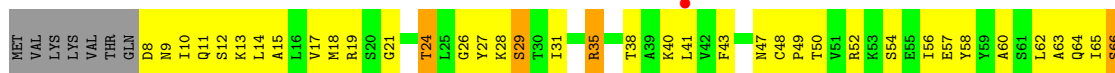

• Molecule 7: RPL30

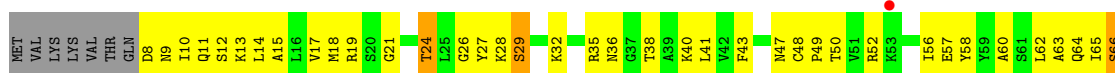

• Molecule 8: RPL35A

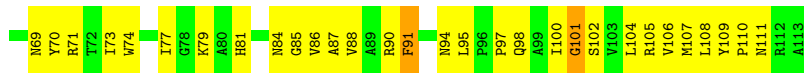

• Molecule 8: RPL35A

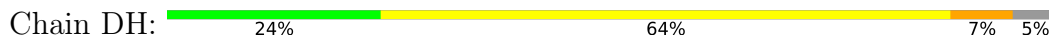

• Molecule 8: RPL35A

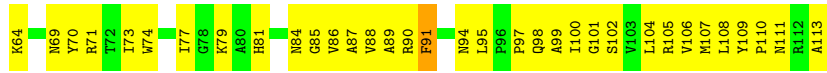

• Molecule 8: RPL35A

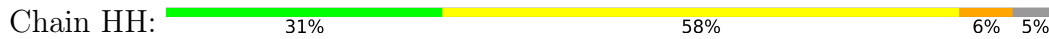



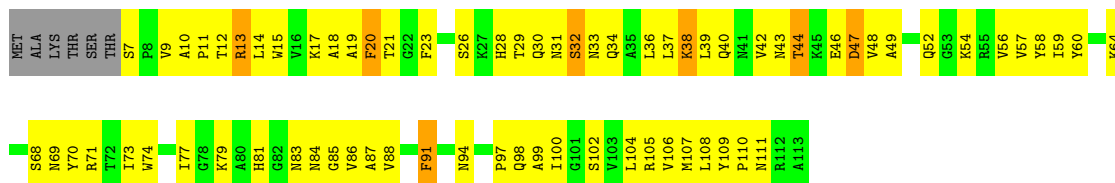

● Molecule 9: TRANSLATION INITIATION FACTOR EIF-6, PUTATIVE FAMILY PROTEIN

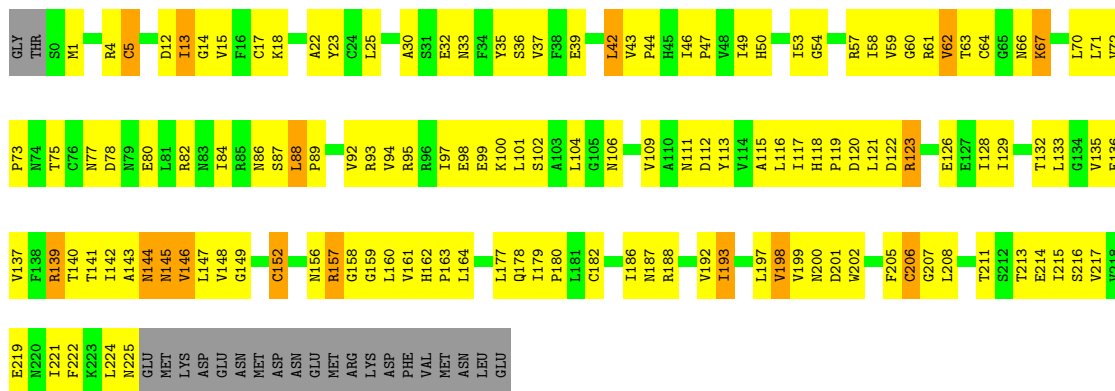
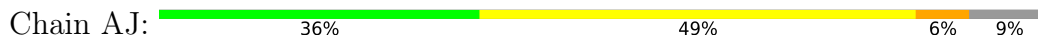

● Molecule 9: TRANSLATION INITIATION FACTOR EIF-6, PUTATIVE FAMILY PROTEIN

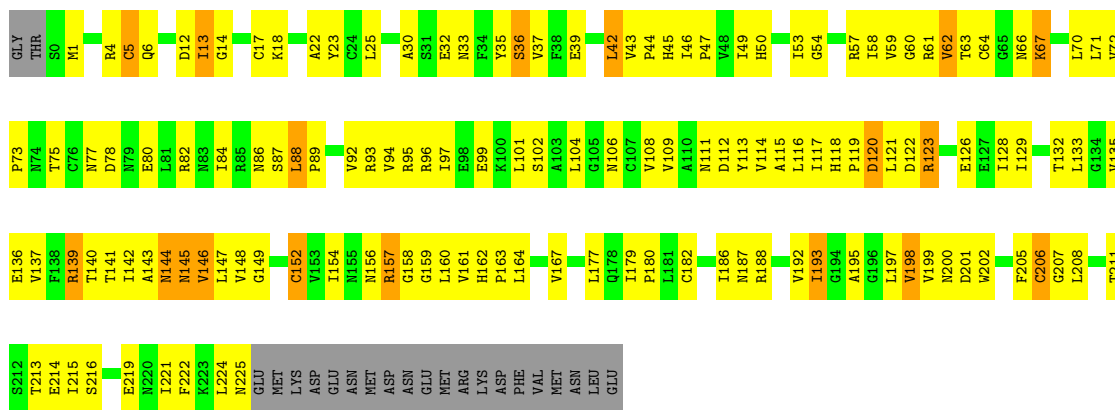

● Molecule 9: TRANSLATION INITIATION FACTOR EIF-6, PUTATIVE FAMILY PROTEIN

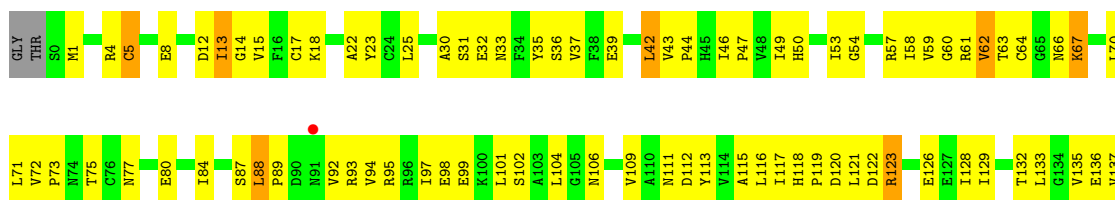





• Molecule 10: UBIQUITIN-60S RIBOSOMAL PROTEIN L40

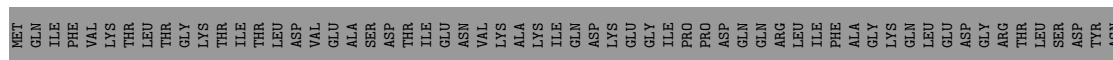

• Molecule 11: RPL34

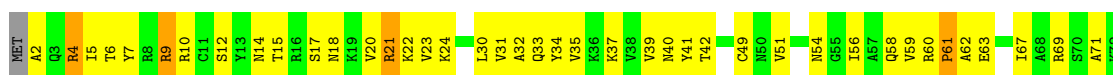

• Molecule 11: RPL34



• Molecule 11: RPL34



• Molecule 11: RPL34

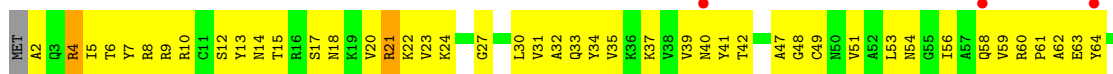

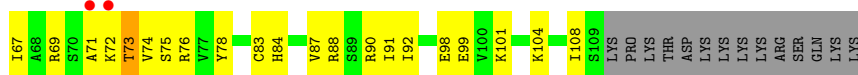

● Molecule 12: RIBOSOMAL PROTEIN L22

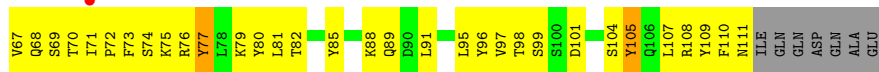
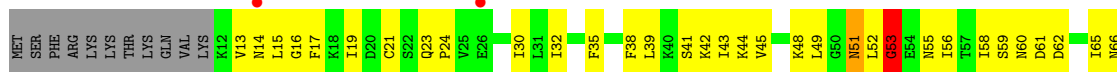

● Molecule 12: RIBOSOMAL PROTEIN L22



● Molecule 12: RIBOSOMAL PROTEIN L22

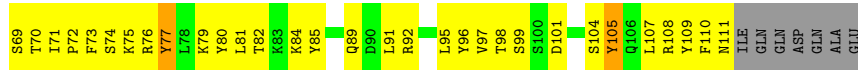

● Molecule 12: RIBOSOMAL PROTEIN L22



● Molecule 13: RPL27



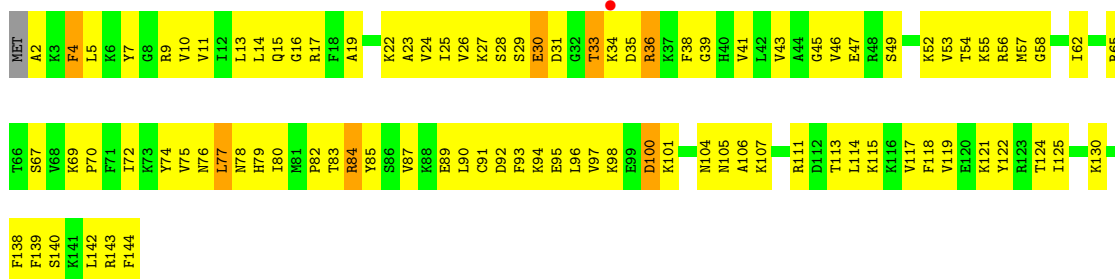

- Molecule 13: RPL27

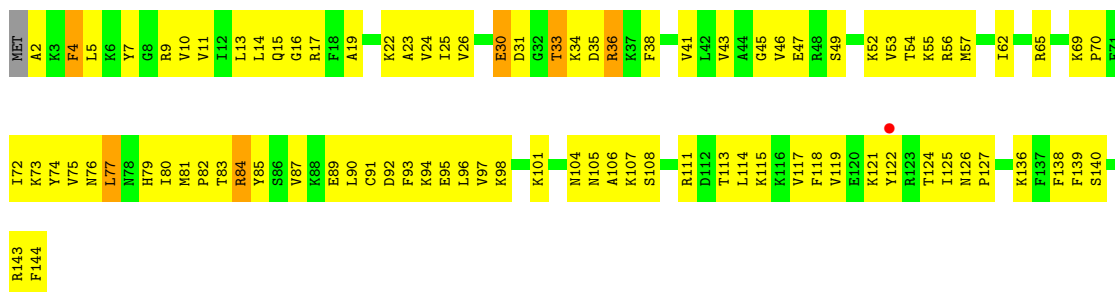

- Molecule 13: RPL27



- Molecule 13: RPL27

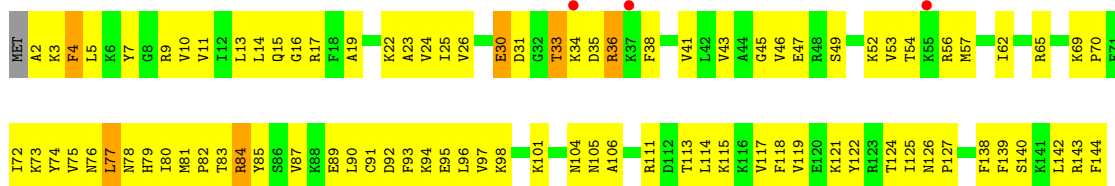
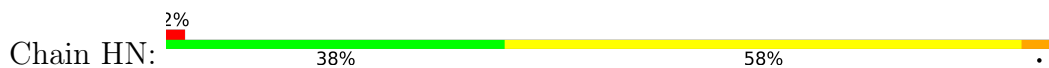

- Molecule 14: RPL28



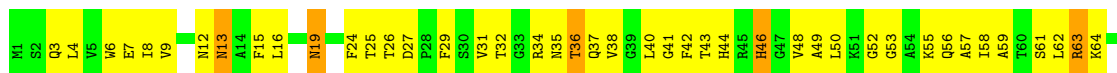

• Molecule 14: RPL28

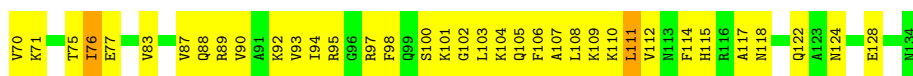
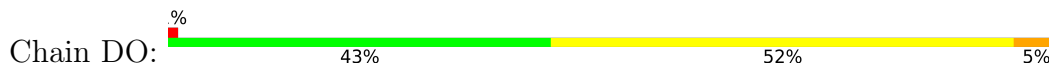

• Molecule 14: RPL28



• Molecule 14: RPL28

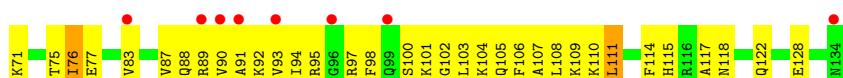
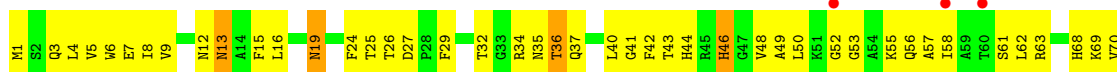

• Molecule 15: RPL38



• Molecule 15: RPL38

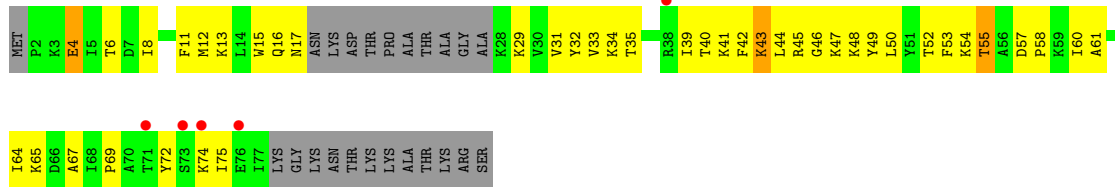

• Molecule 15: RPL38

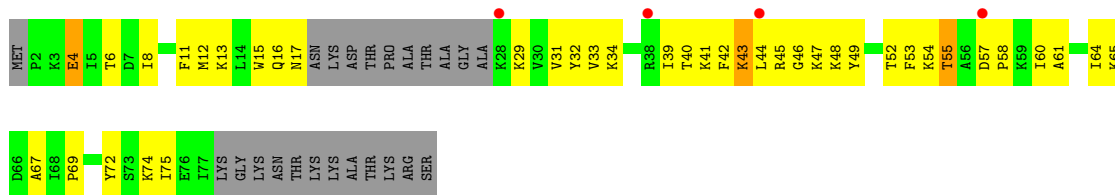

• Molecule 15: RPL38

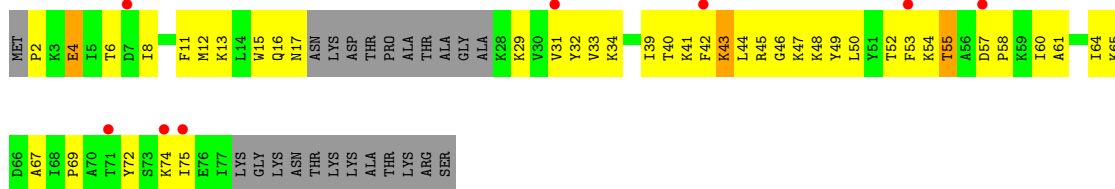

• Molecule 16: 60S RIBOSOMAL PROTEIN L36

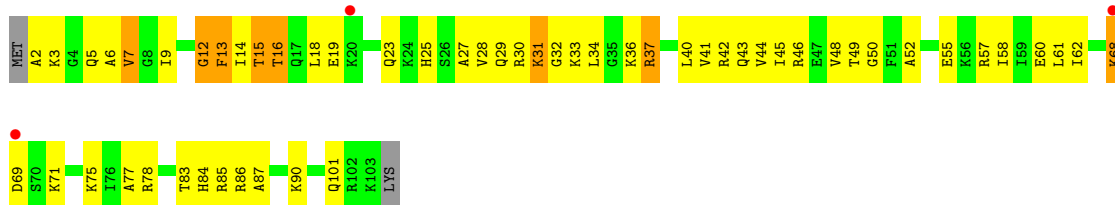

• Molecule 16: 60S RIBOSOMAL PROTEIN L36



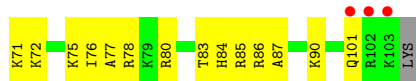

- Molecule 16: 60S RIBOSOMAL PROTEIN L36

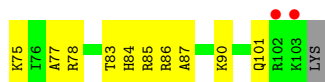

- Molecule 16: 60S RIBOSOMAL PROTEIN L36

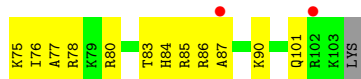

- Molecule 17: RPL29

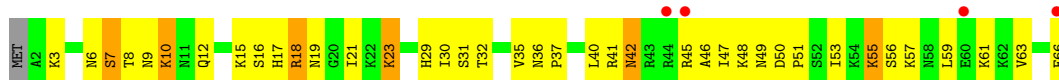

- Molecule 17: RPL29

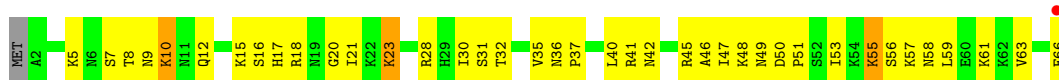

- Molecule 17: RPL29

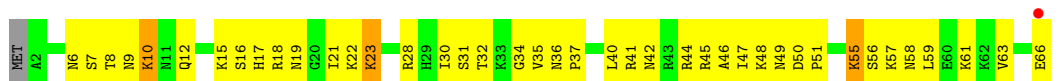
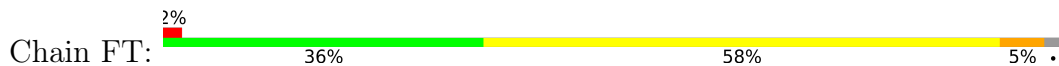

- Molecule 17: RPL29





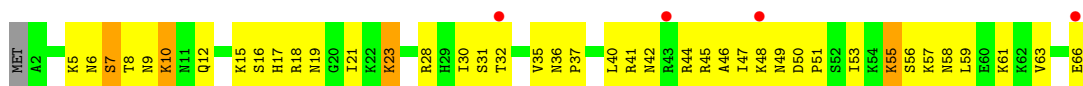

• Molecule 18: RPL13

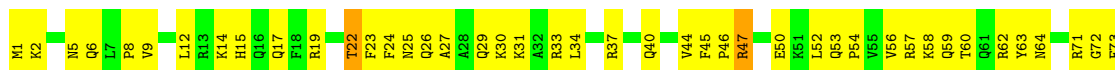
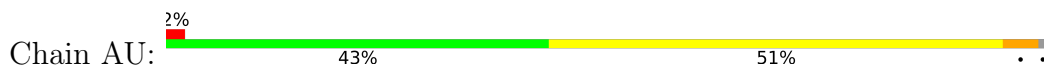

• Molecule 18: RPL13

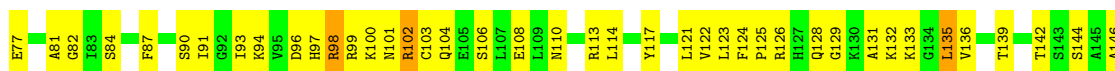

• Molecule 18: RPL13

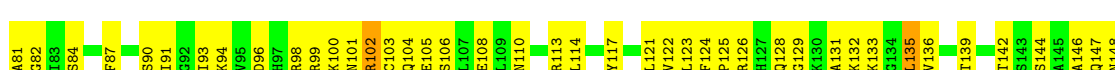

• Molecule 18: RPL13

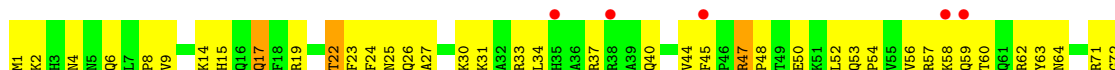
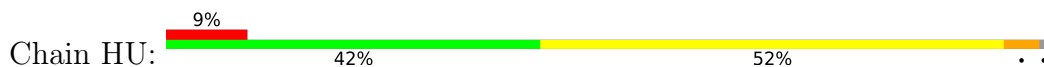

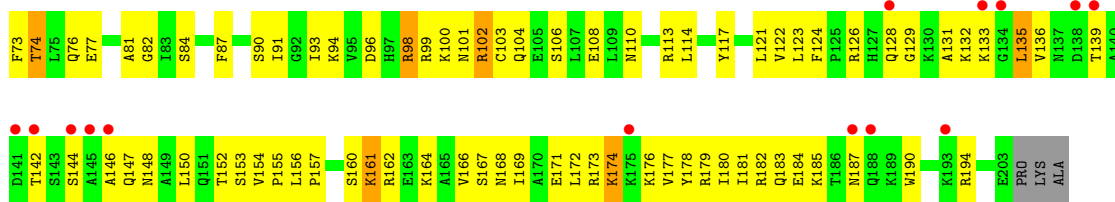

- Molecule 19: RPL18A

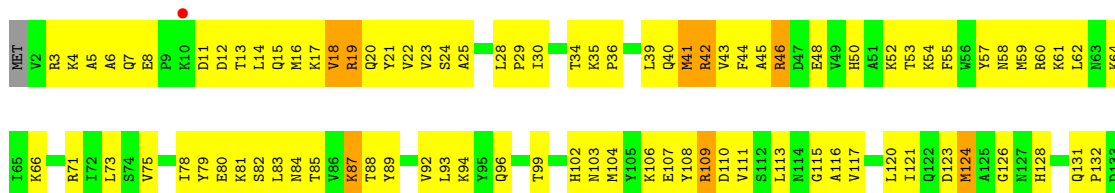

- Molecule 19: RPL18A



- Molecule 19: RPL18A

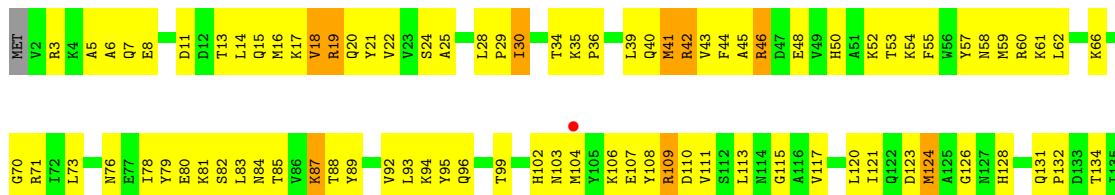

- Molecule 19: RPL18A



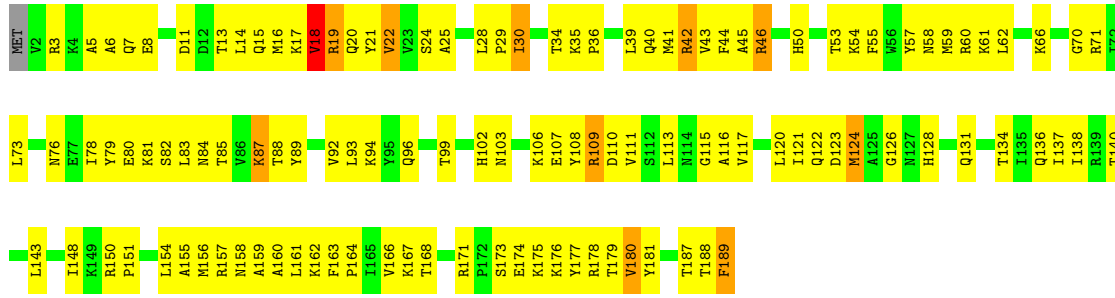

• Molecule 20: 5.8S RRNA

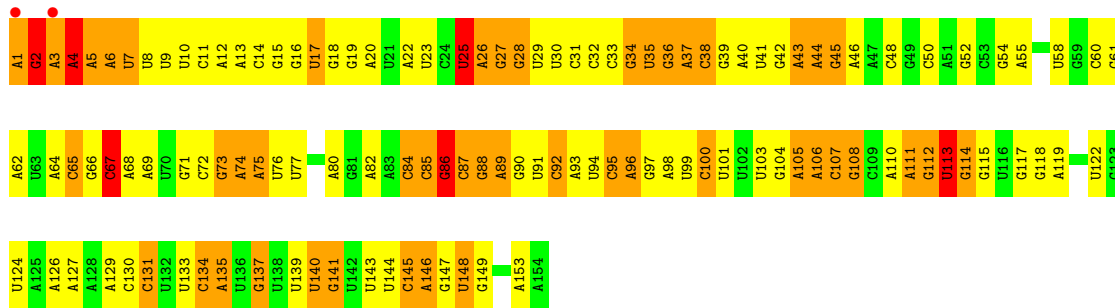
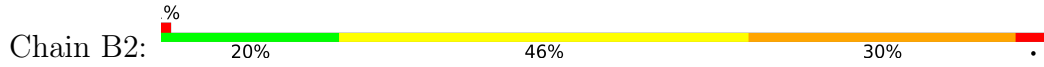

• Molecule 20: 5.8S RRNA

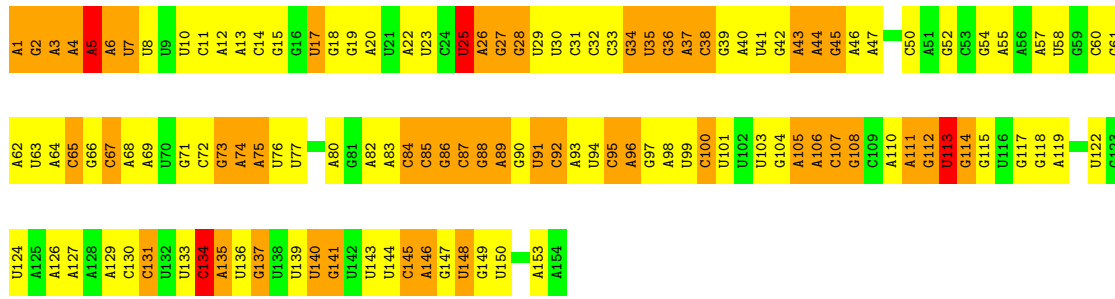
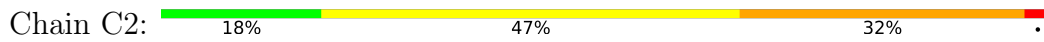

• Molecule 20: 5.8S RRNA

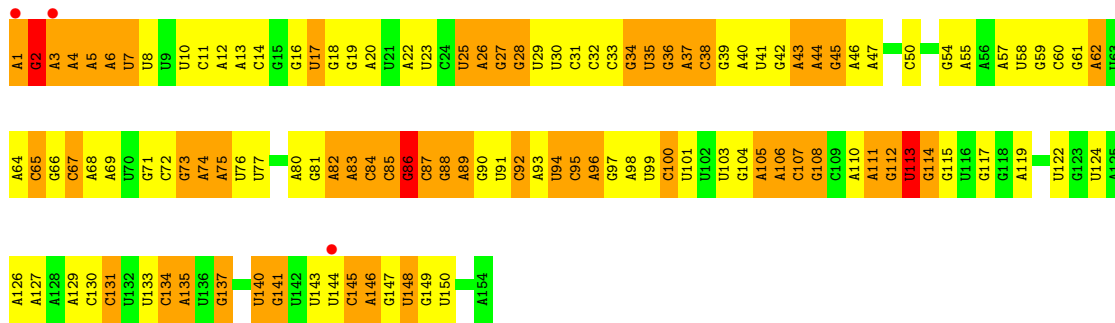
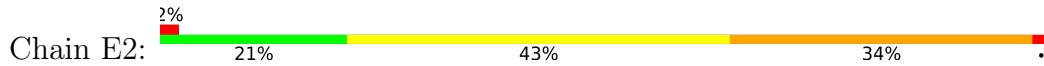

- Molecule 20: 5.8S RRNA

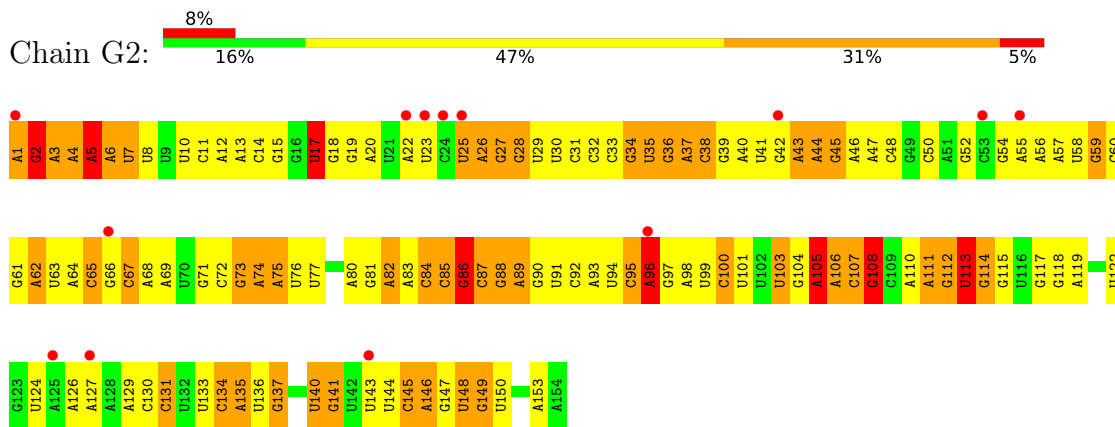

- Molecule 21: 5S RRNA

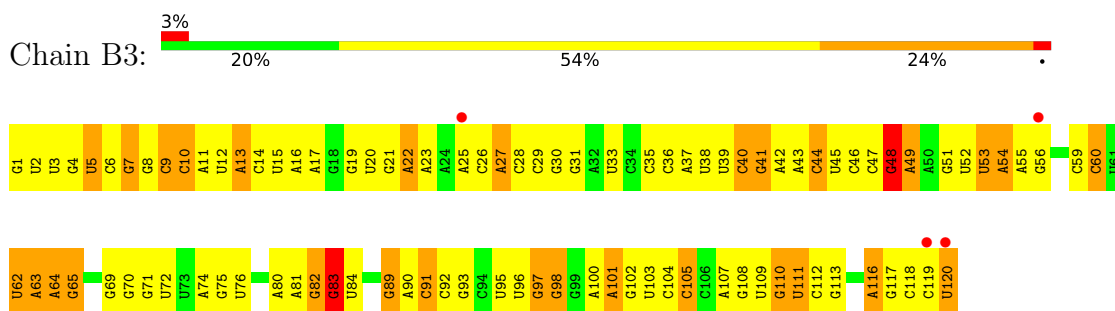

- Molecule 21: 5S RRNA



- Molecule 21: 5S RRNA

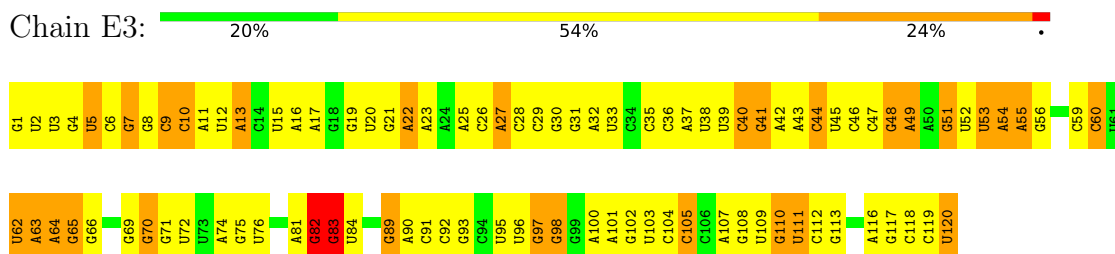

- Molecule 21: 5S RRNA

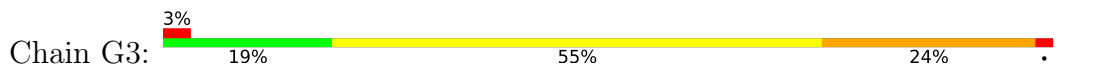

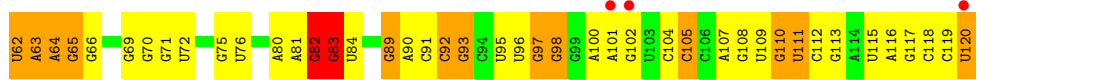
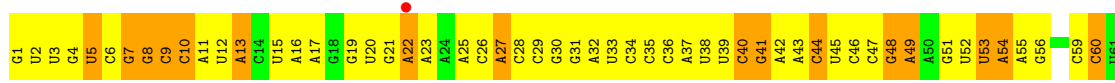

• Molecule 22: RPL8

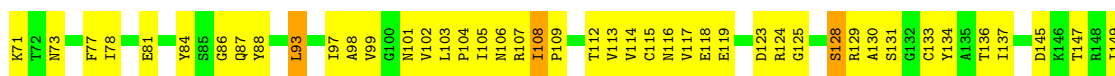

• Molecule 22: RPL8

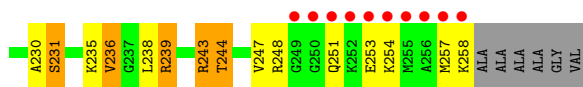
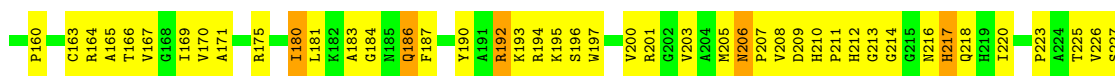
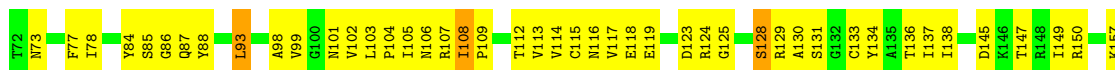
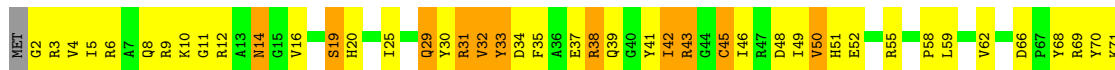

• Molecule 22: RPL8

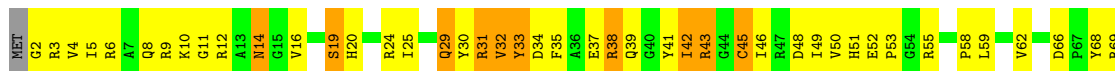

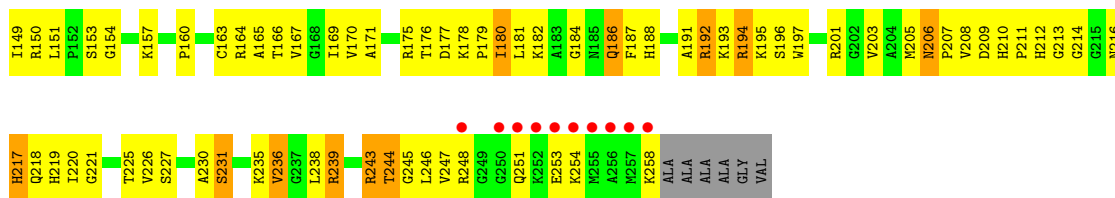

• Molecule 22: RPL8

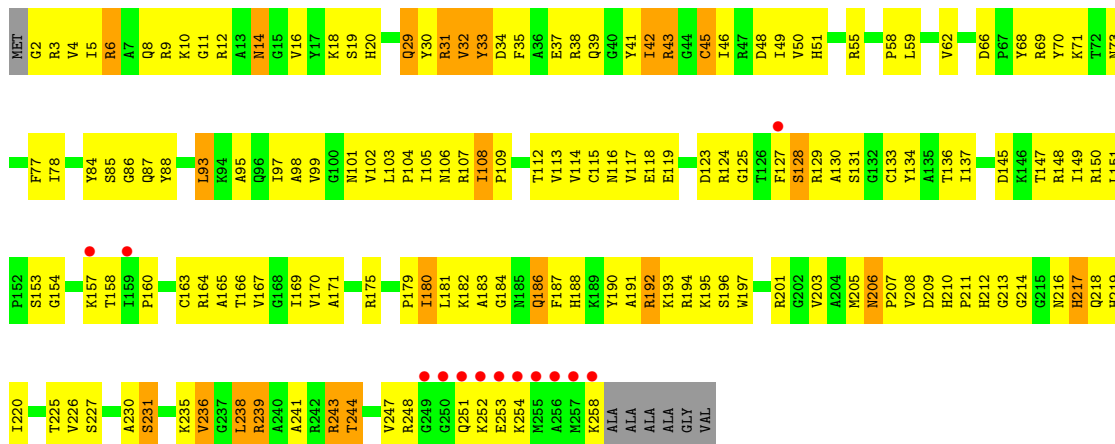

• Molecule 23: RIBOSOMAL PROTEIN L3

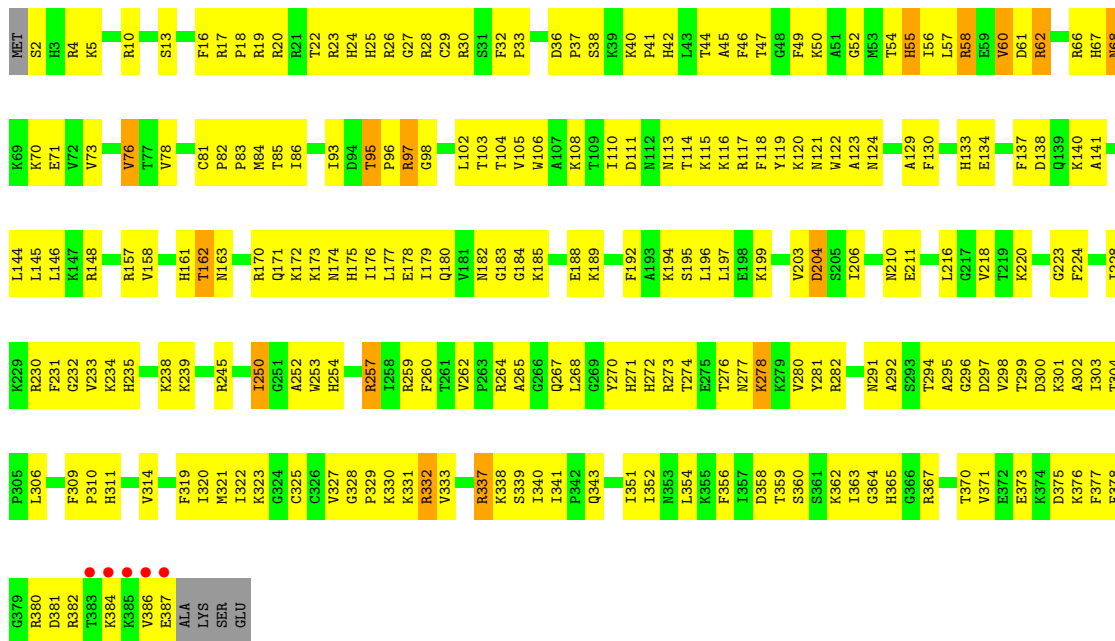

• Molecule 23: RIBOSOMAL PROTEIN L3



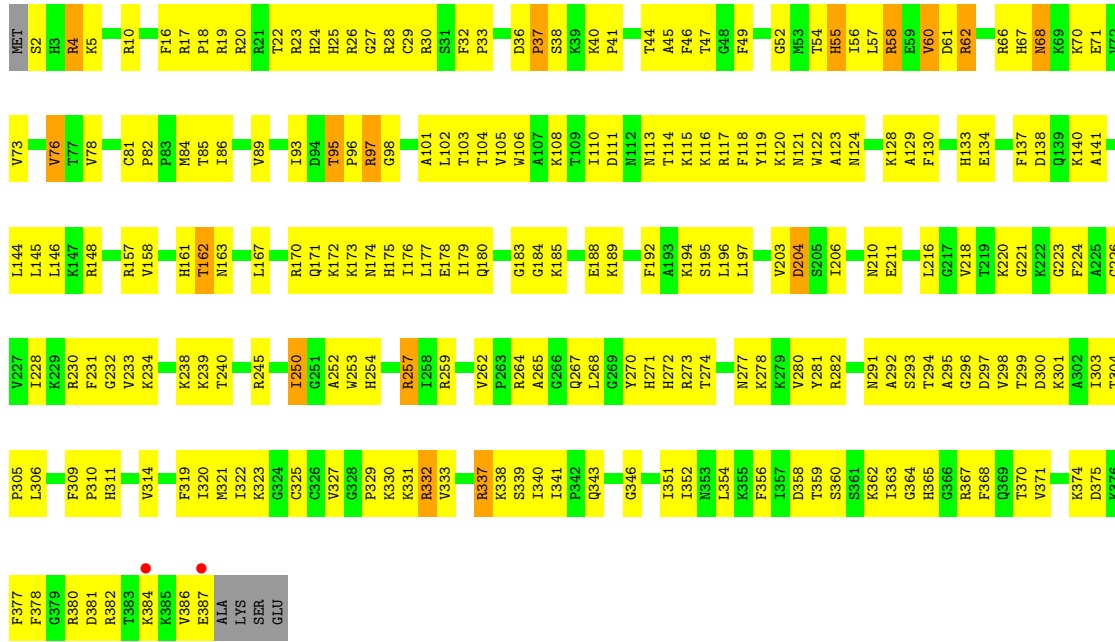

• Molecule 23: RIBOSOMAL PROTEIN L3

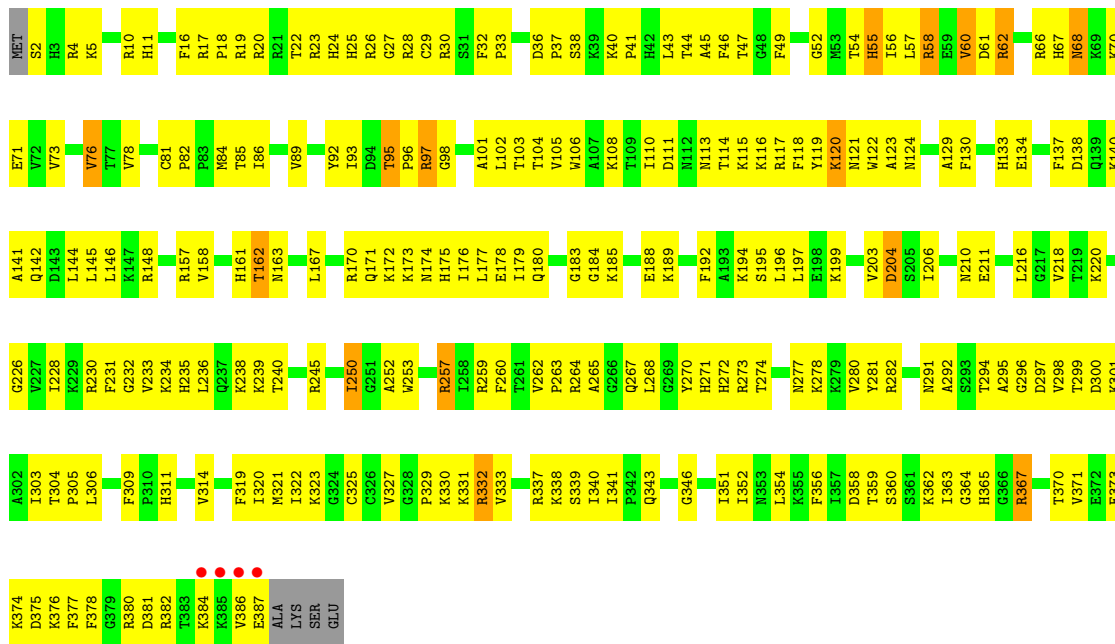

• Molecule 23: RIBOSOMAL PROTEIN L3

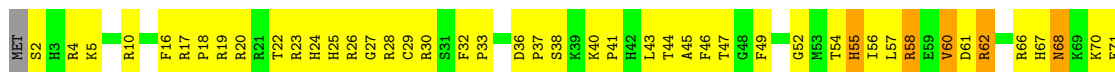

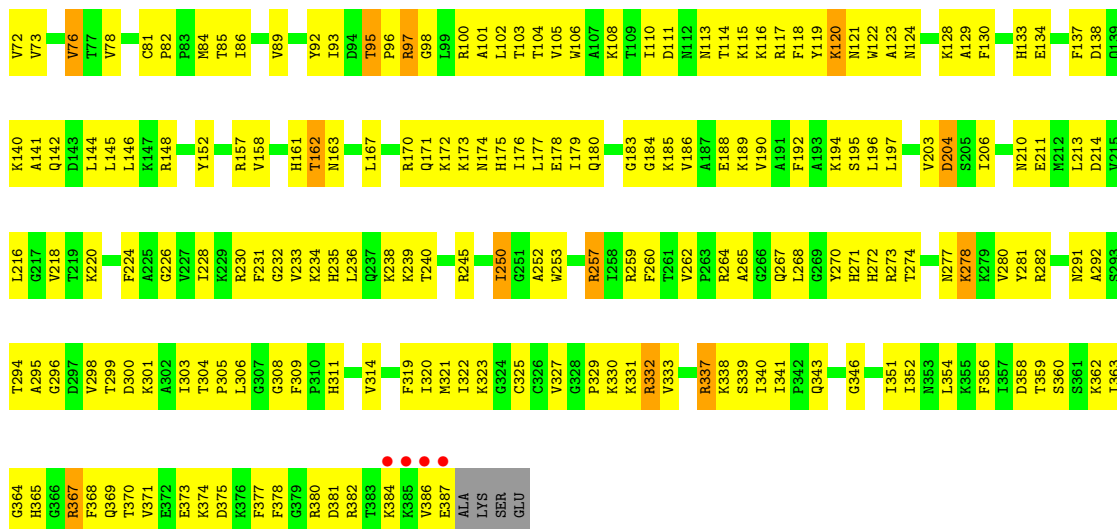

● Molecule 24: RPL4

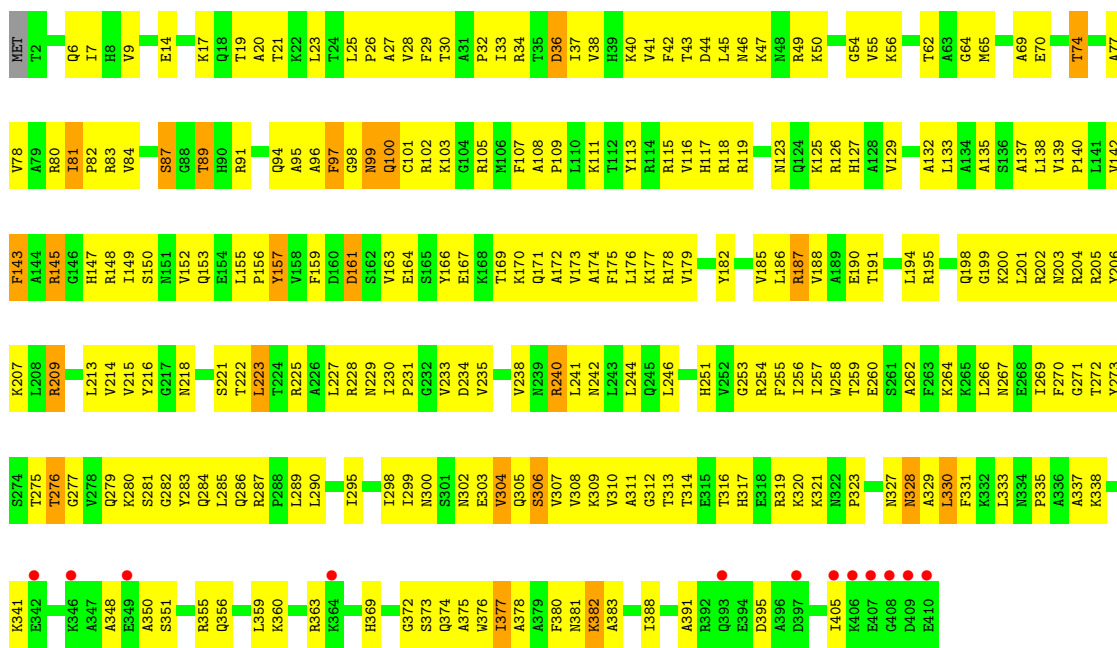

● Molecule 24: RPL4

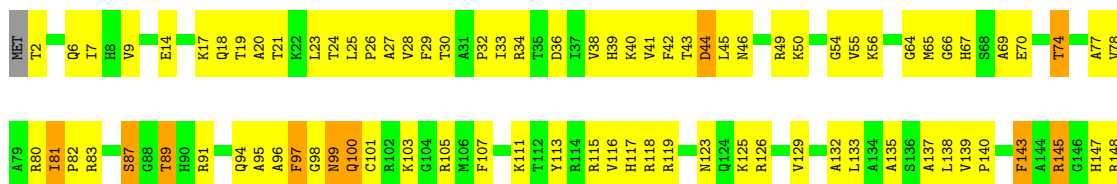



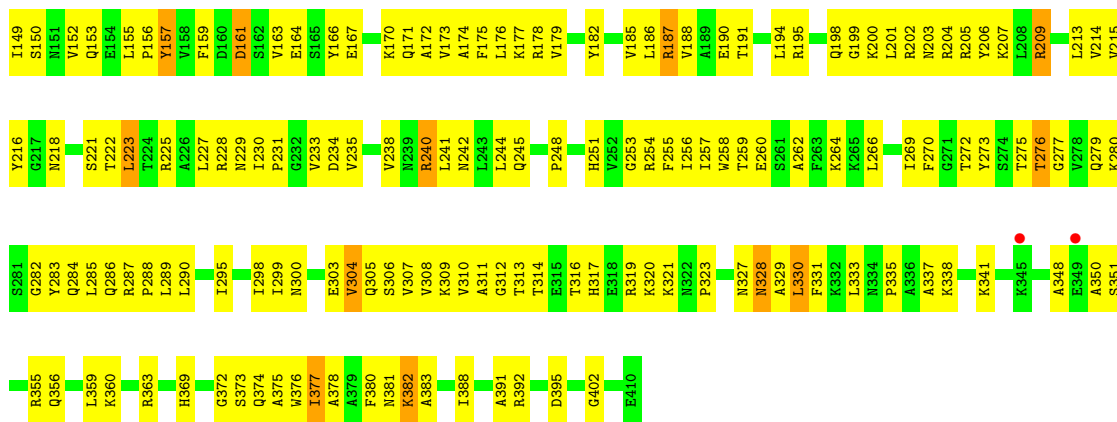

● Molecule 24: RPL4

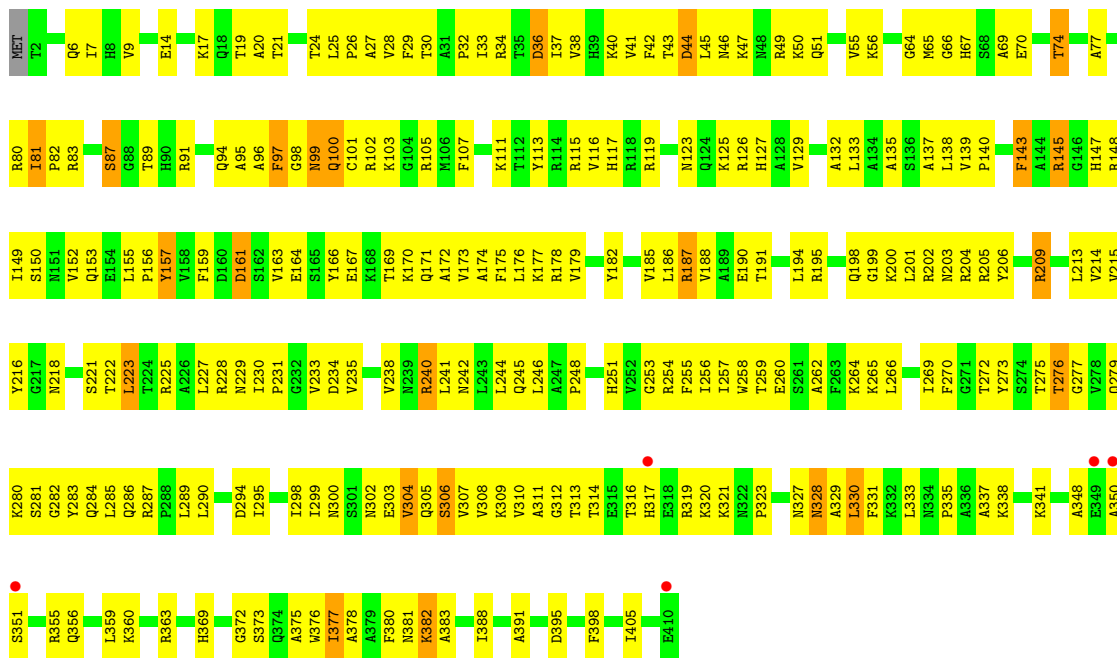

● Molecule 24: RPL4

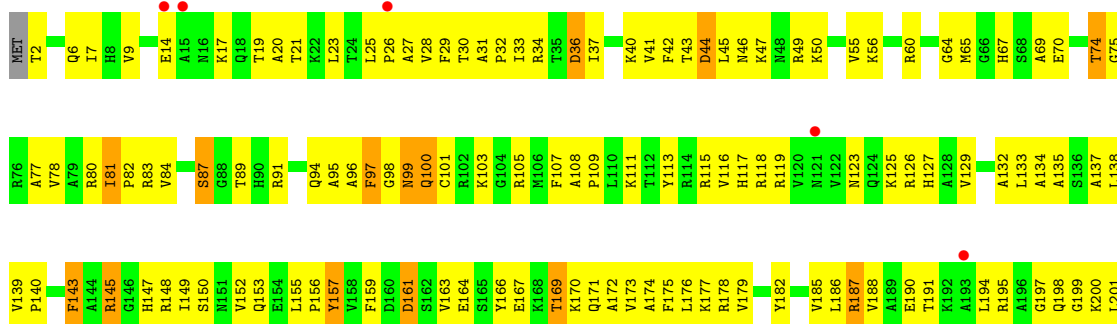

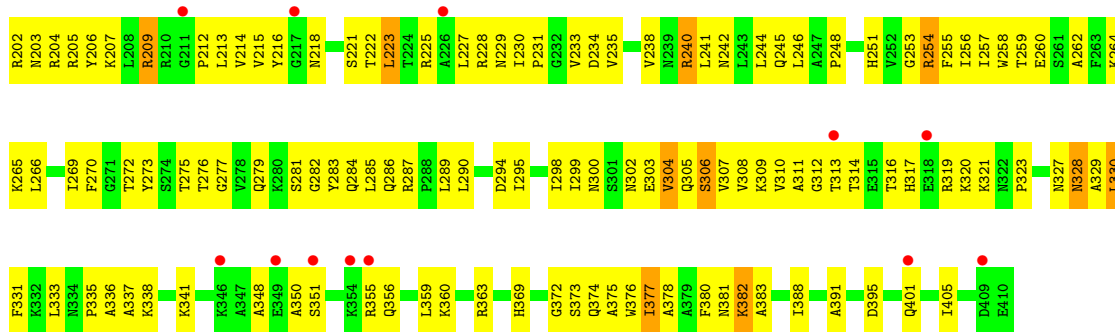

• Molecule 25: 60S RIBOSOMAL PROTEIN L11

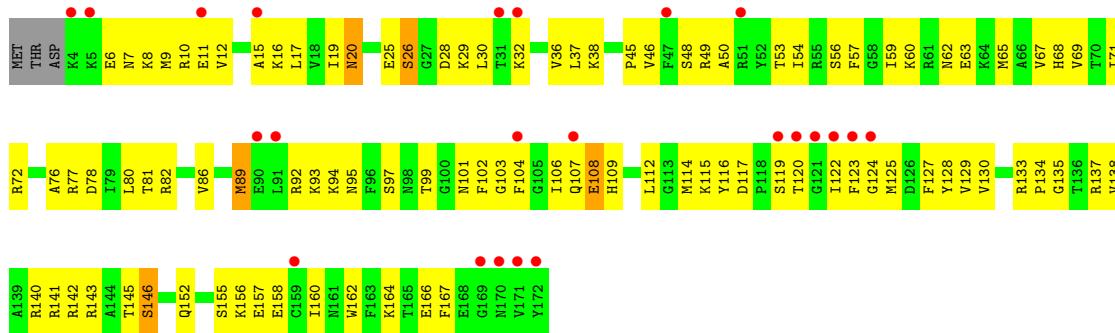
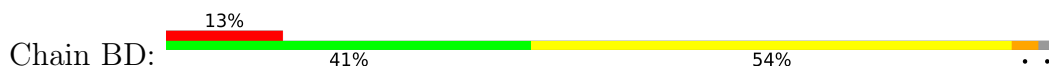

• Molecule 25: 60S RIBOSOMAL PROTEIN L11

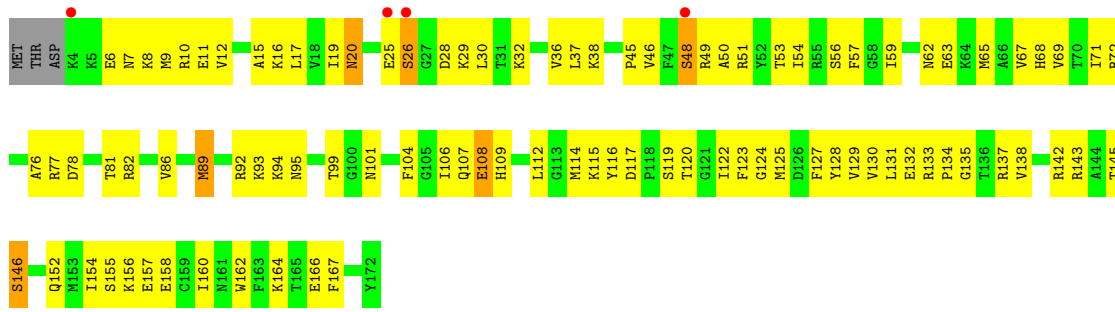
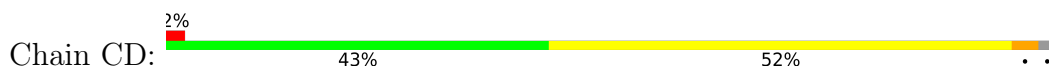

• Molecule 25: 60S RIBOSOMAL PROTEIN L11

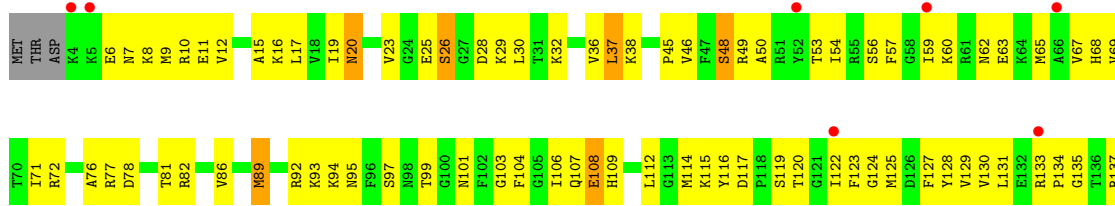

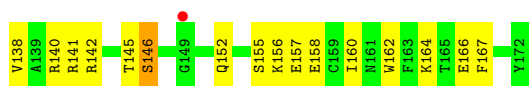

- Molecule 25: 60S RIBOSOMAL PROTEIN L11

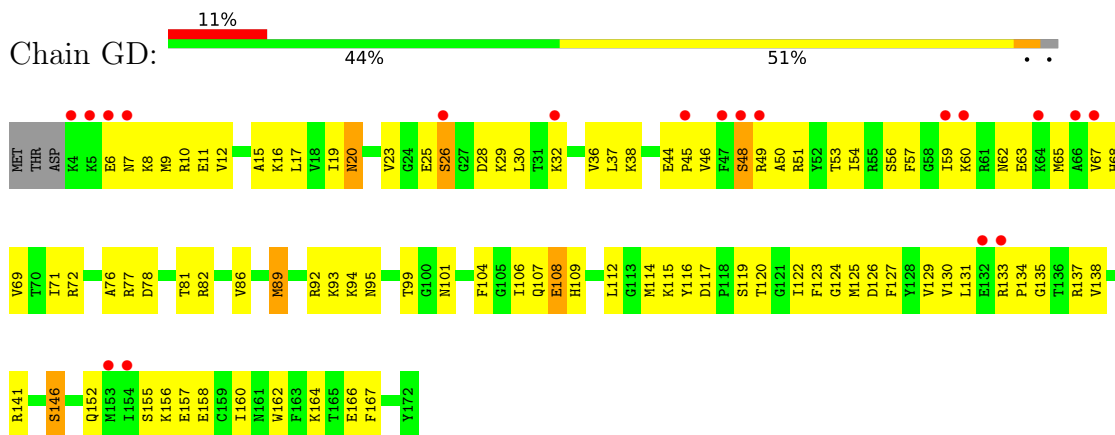

- Molecule 26: 60S RIBOSOMAL PROTEIN L9



- Molecule 26: 60S RIBOSOMAL PROTEIN L9

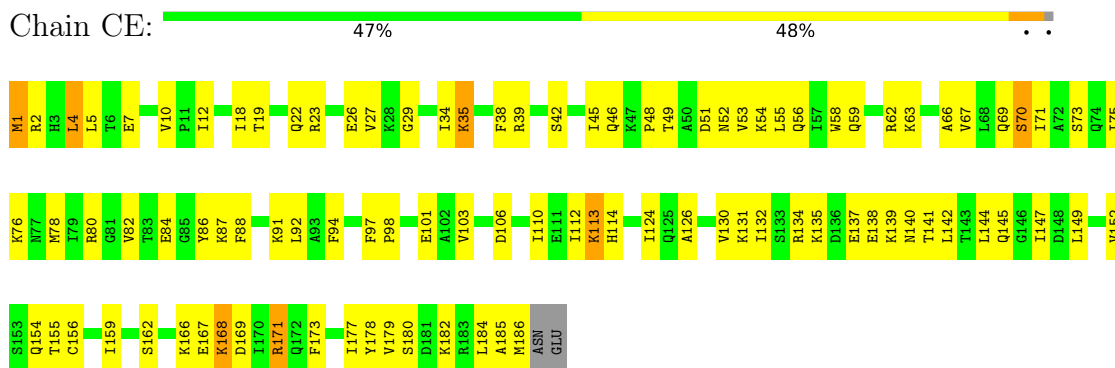

- Molecule 26: 60S RIBOSOMAL PROTEIN L9



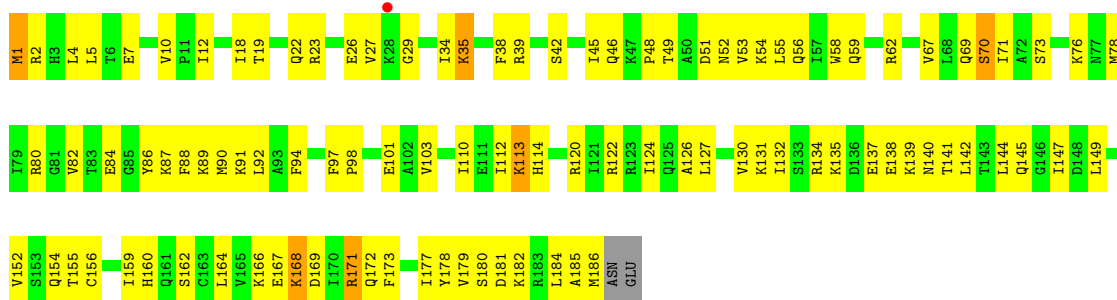

• Molecule 26: 60S RIBOSOMAL PROTEIN L9

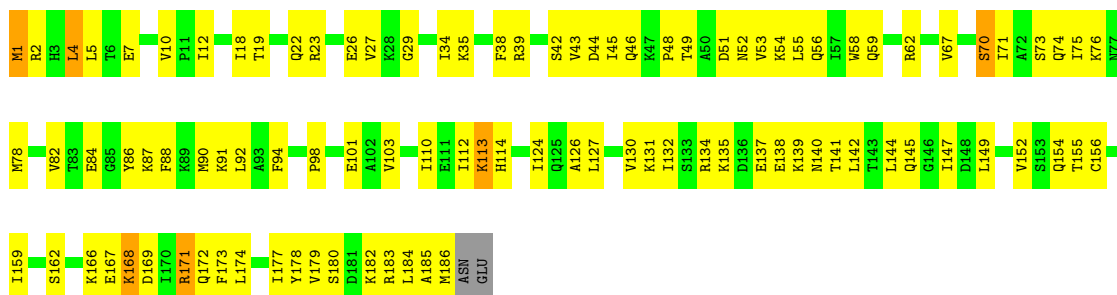

• Molecule 27: RPL7A

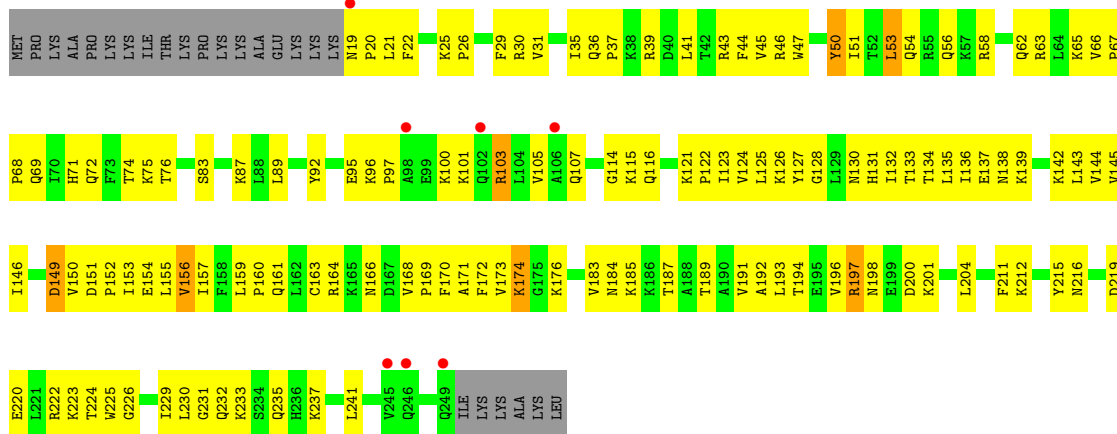

• Molecule 27: RPL7A

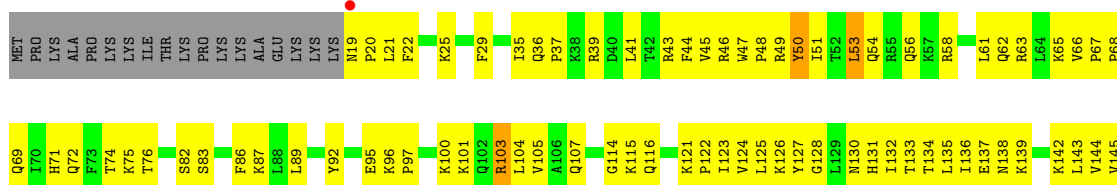

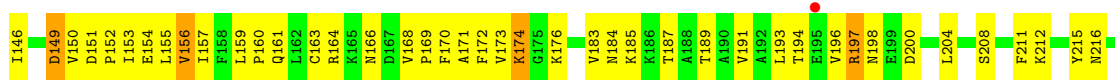

• Molecule 27: RPL7A

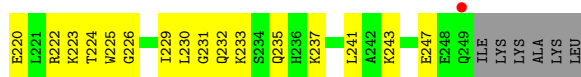
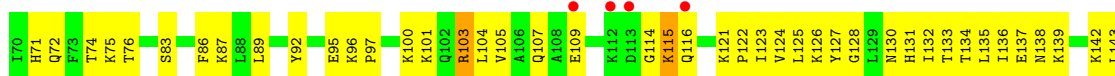

• Molecule 27: RPL7A

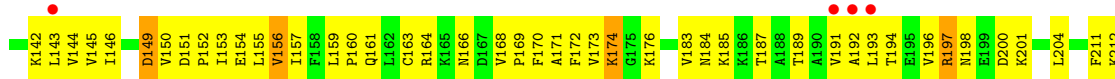
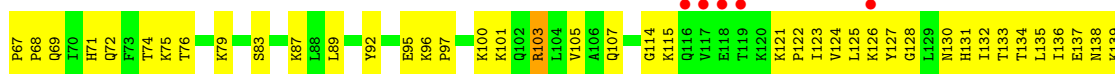
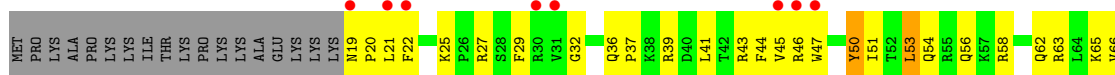

• Molecule 28: RPLP0





• Molecule 28: RPLP0

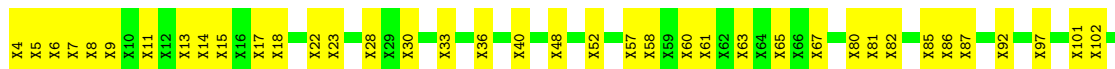

• Molecule 28: RPLP0



• Molecule 28: RPLP0

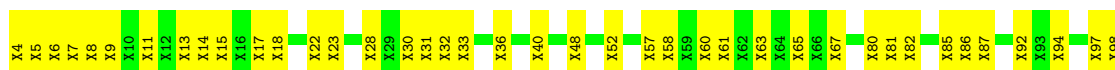

• Molecule 29: 60S RIBOSOMAL PROTEIN L10

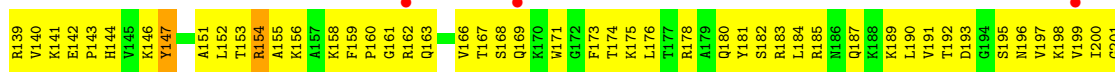
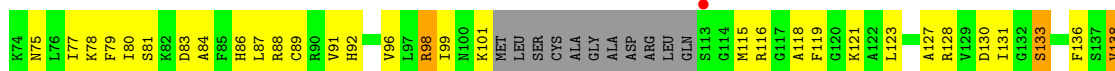
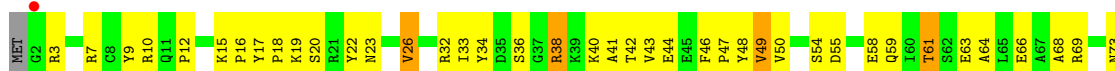

• Molecule 29: 60S RIBOSOMAL PROTEIN L10

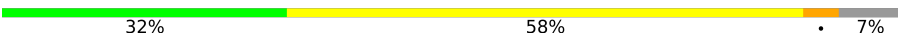
Chain CH: 

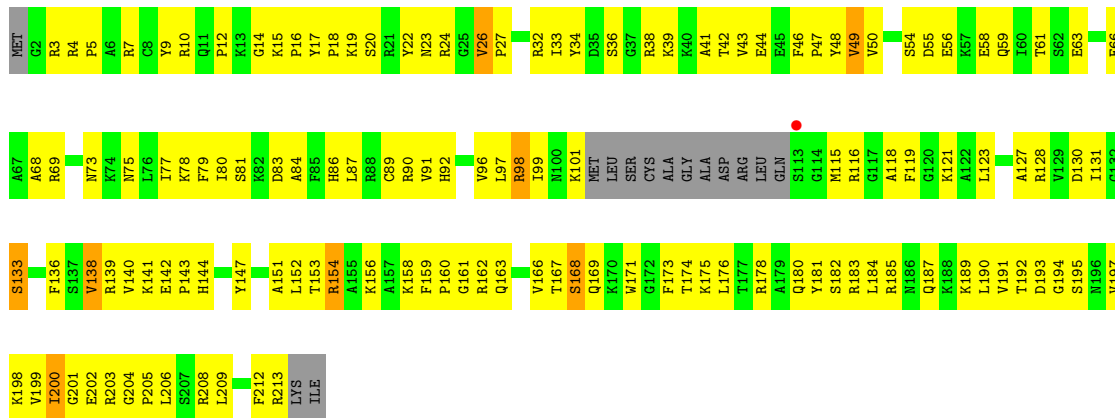

• Molecule 29: 60S RIBOSOMAL PROTEIN L10

Chain EH: 

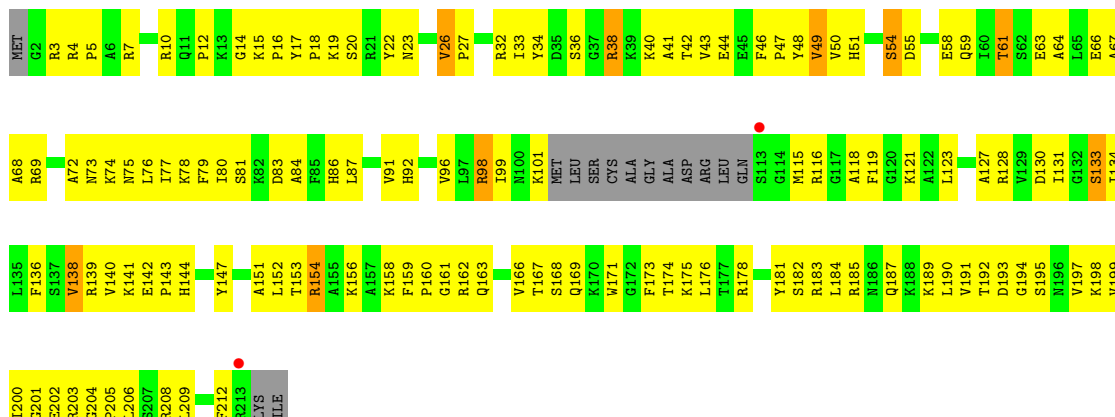

• Molecule 29: 60S RIBOSOMAL PROTEIN L10

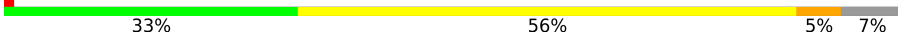
Chain GH: 

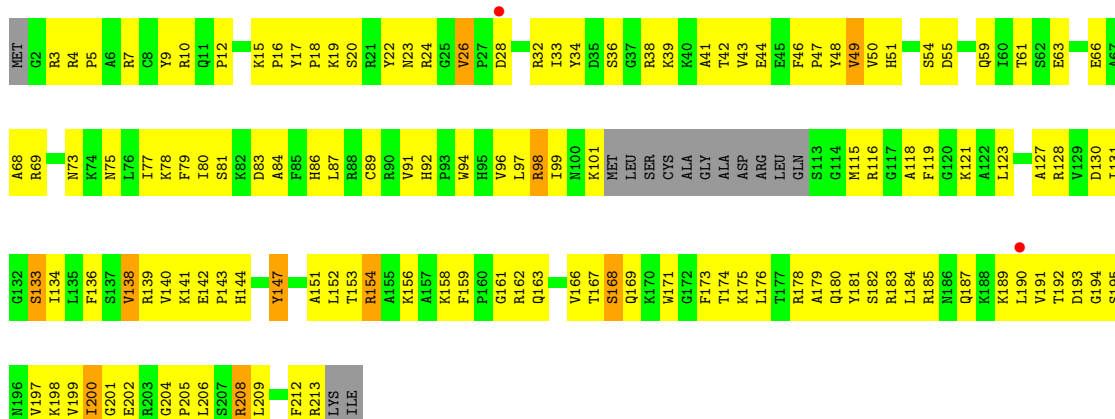

- Molecule 30: 60S RIBOSOMAL PROTEIN L13A



- Molecule 30: 60S RIBOSOMAL PROTEIN L13A



- Molecule 30: 60S RIBOSOMAL PROTEIN L13A



- Molecule 30: 60S RIBOSOMAL PROTEIN L13A

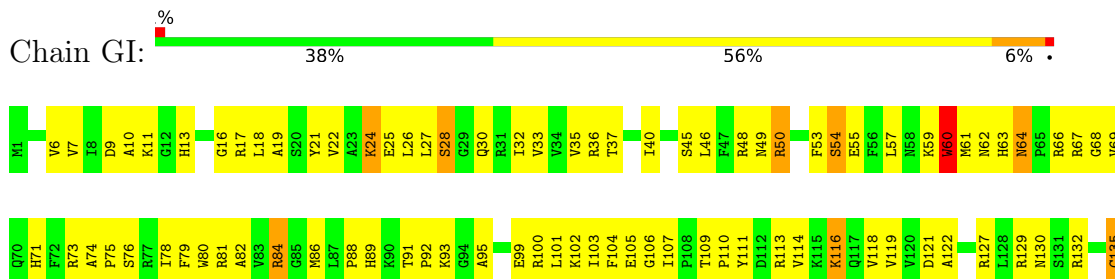



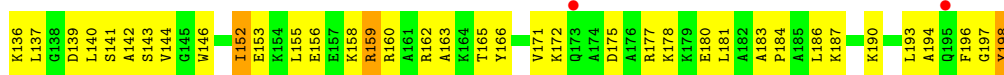

- Molecule 31: RPL23

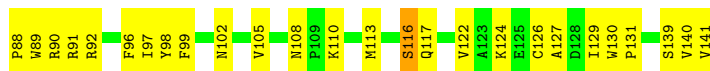

- Molecule 31: RPL23

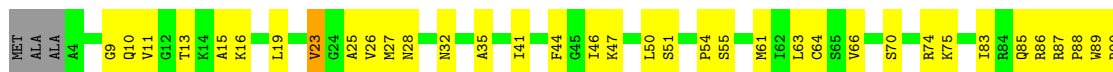

- Molecule 31: RPL23

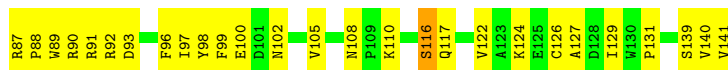

- Molecule 31: RPL23

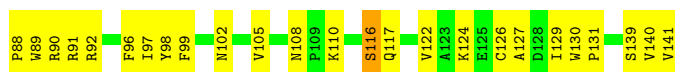
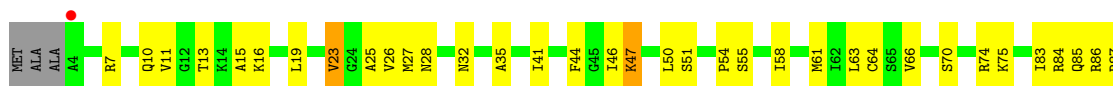

- Molecule 32: 60S RIBOSOMAL PROTEIN L27A



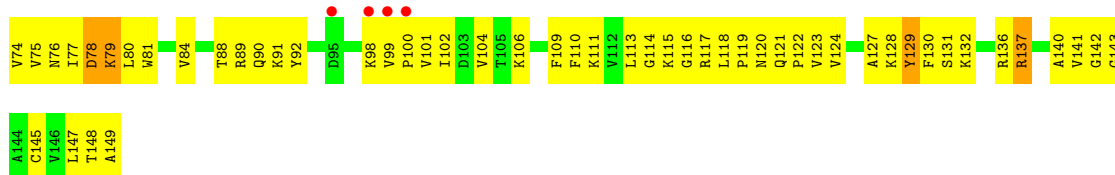

- Molecule 32: 60S RIBOSOMAL PROTEIN L27A

Chain CK: 38% 54% 7% ..

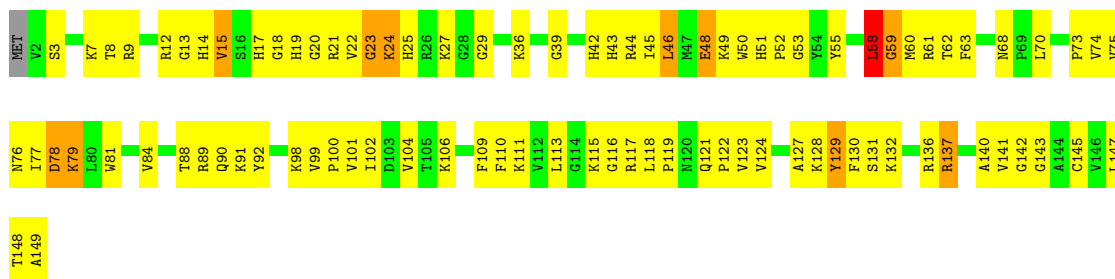

- Molecule 32: 60S RIBOSOMAL PROTEIN L27A

Chain EK: 36% 54% 8% ..

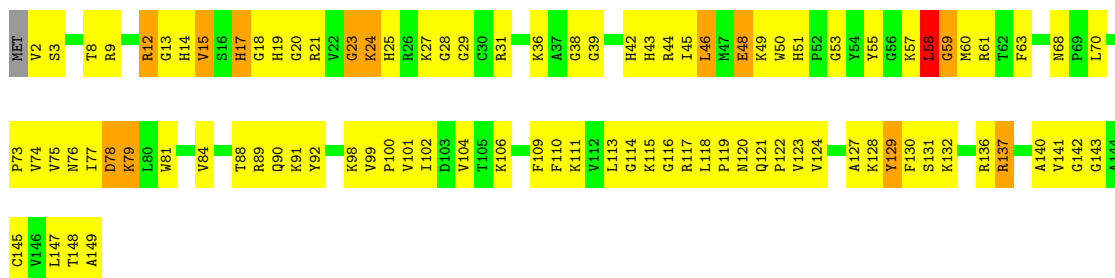

- Molecule 32: 60S RIBOSOMAL PROTEIN L27A

Chain GK: 7% 37% 54% 7% ..

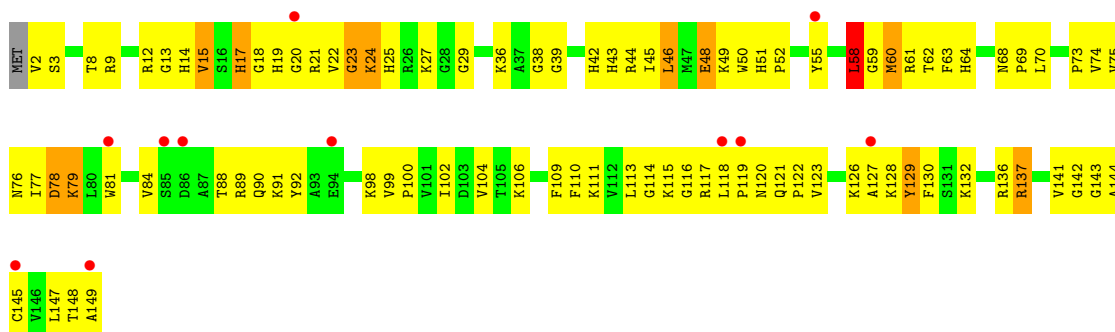

- Molecule 33: RIBOSOMAL PROTEIN L15

Chain BL: 43% 54% ..

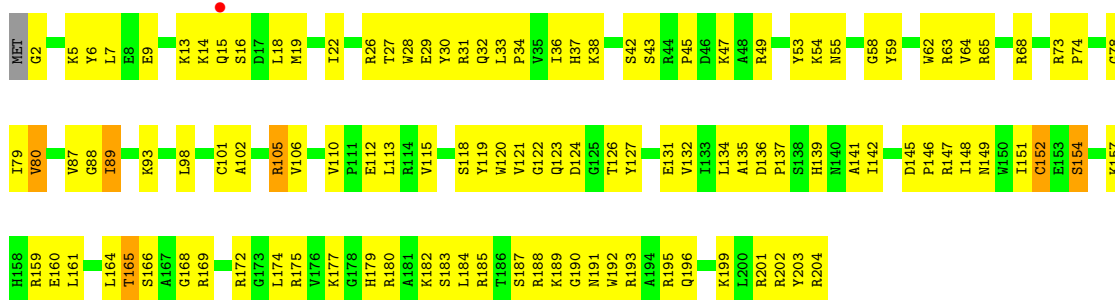

- Molecule 33: RIBOSOMAL PROTEIN L15

Chain CL: 38% 58%

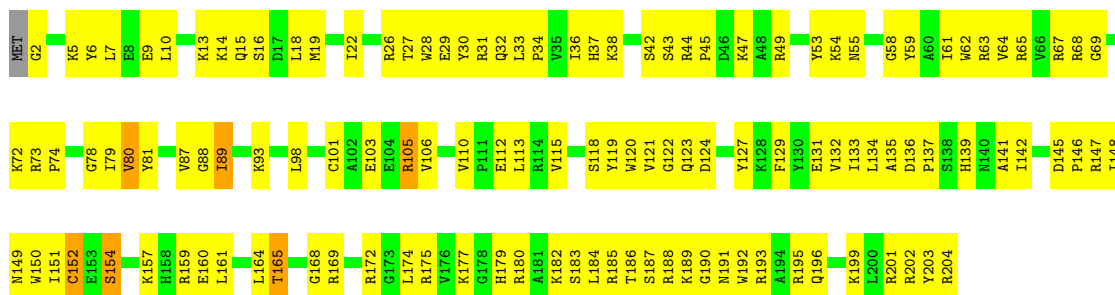

- Molecule 33: RIBOSOMAL PROTEIN L15

Chain EL: 38% 59%

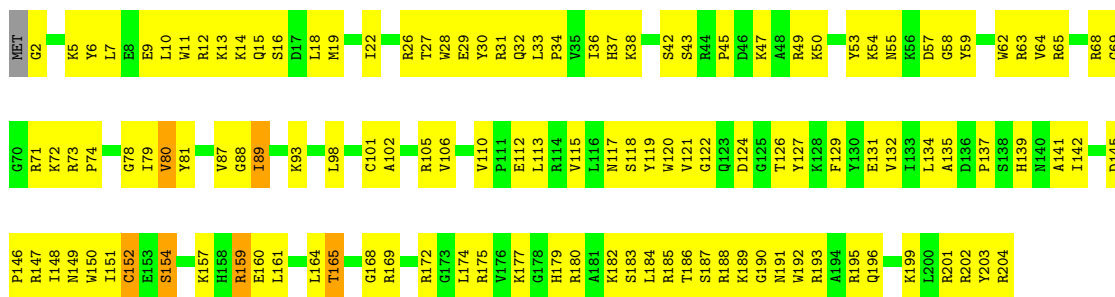

- Molecule 33: RIBOSOMAL PROTEIN L15

Chain GL: 3% 37% 58%

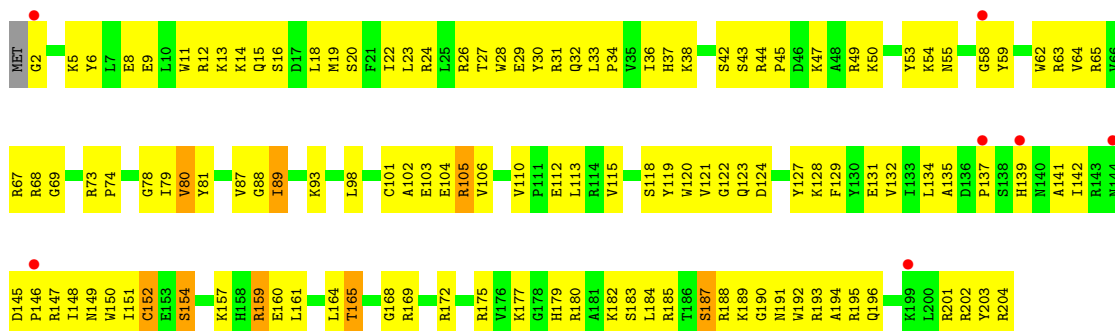

• Molecule 34: 60S RIBOSOMAL PROTEIN L5

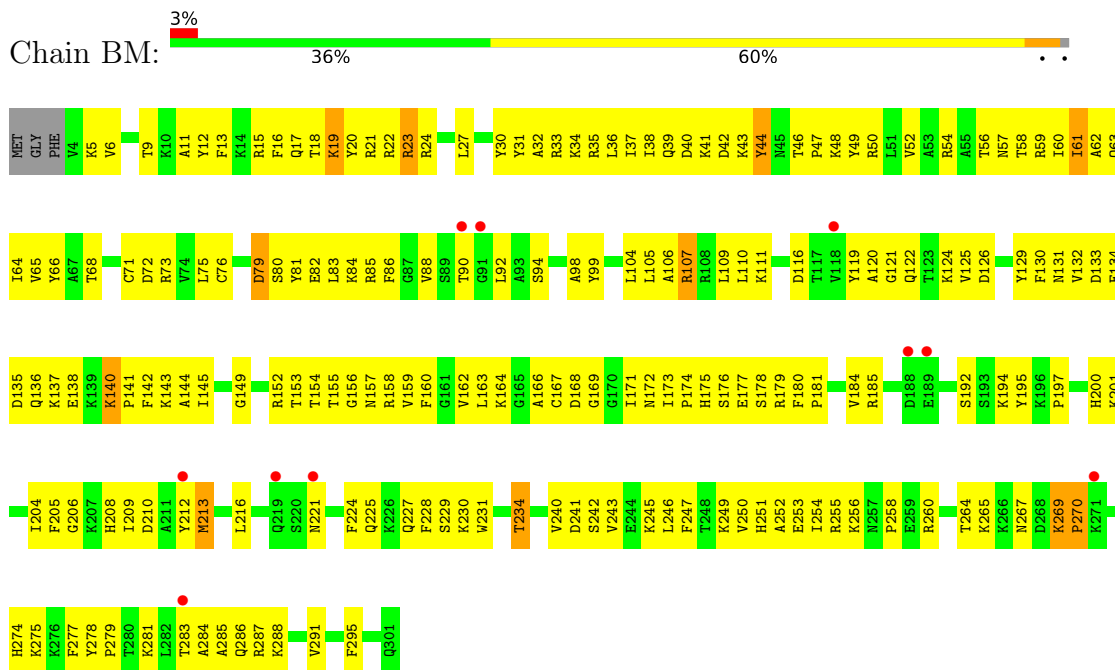

• Molecule 34: 60S RIBOSOMAL PROTEIN L5

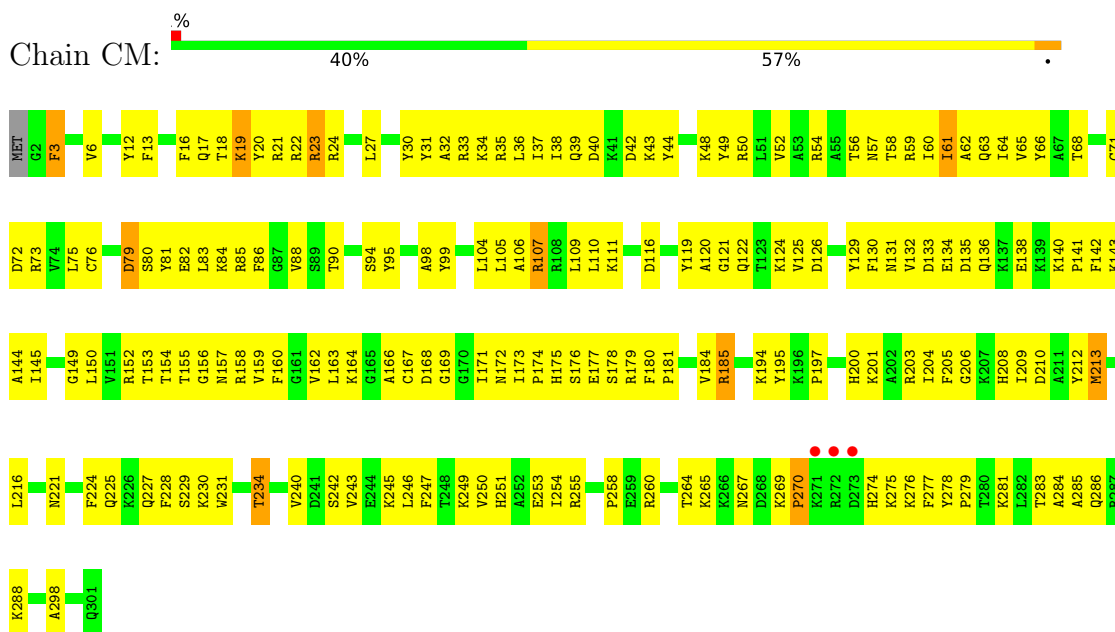

• Molecule 34: 60S RIBOSOMAL PROTEIN L5

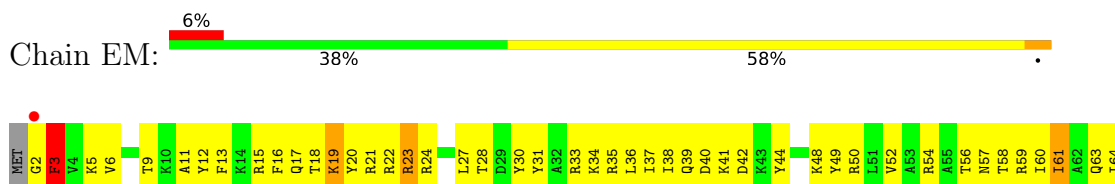



• Molecule 34: 60S RIBOSOMAL PROTEIN L5

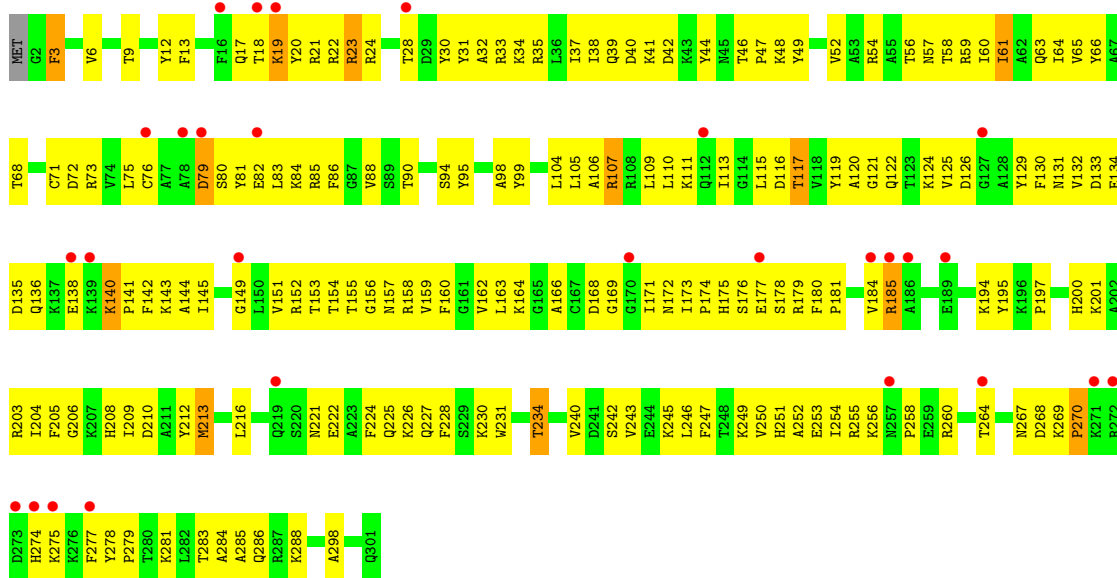

• Molecule 35: RPL18

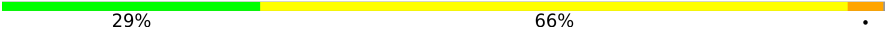

• Molecule 35: RPL18

Chain CN:  29% 66%

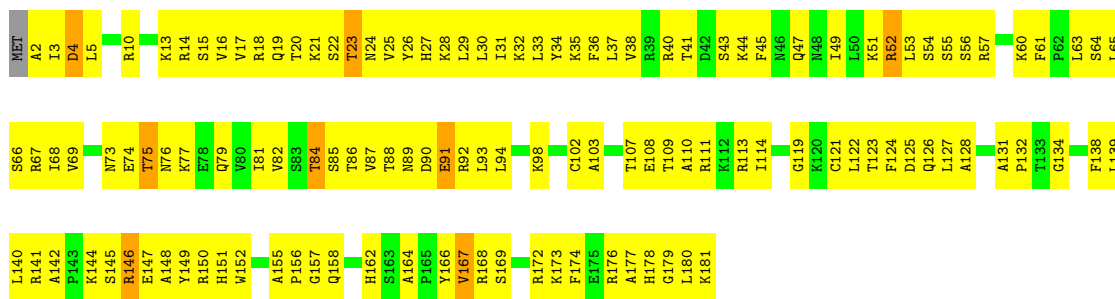

• Molecule 35: RPL18

Chain EN:  29% 65% 5%

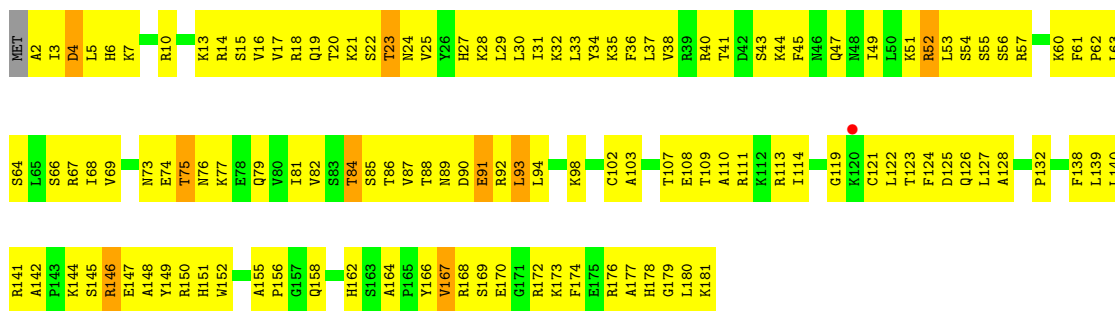

• Molecule 35: RPL18

Chain GN:  2% 31% 62% 6%

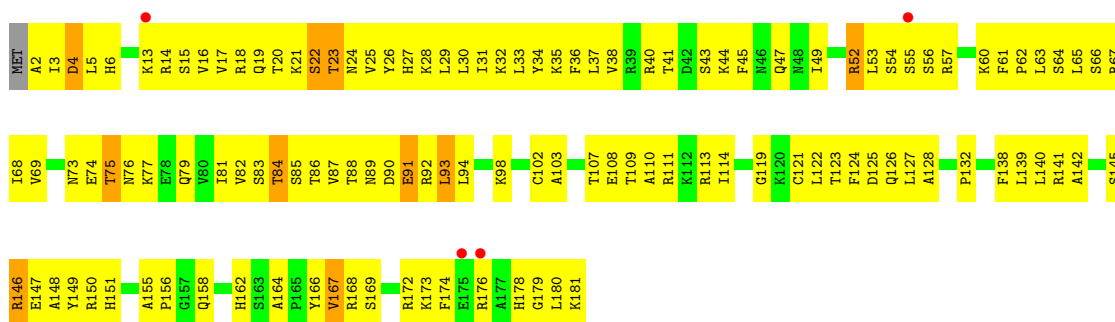

• Molecule 36: RPL19

Chain BO:  8% 49% 48%

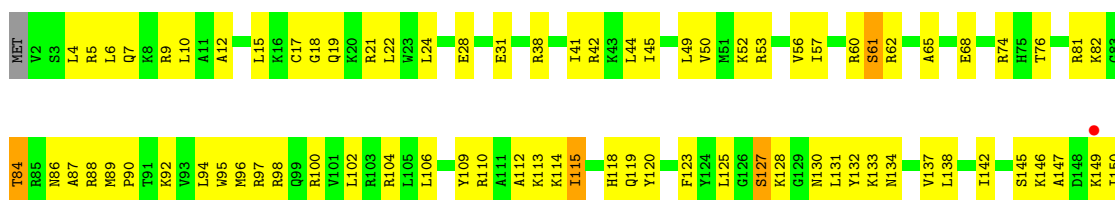

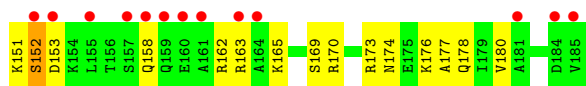

• Molecule 36: RPL19

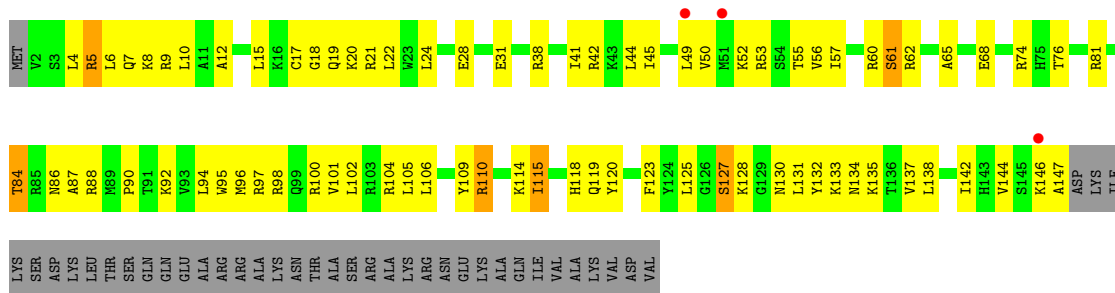

• Molecule 36: RPL19

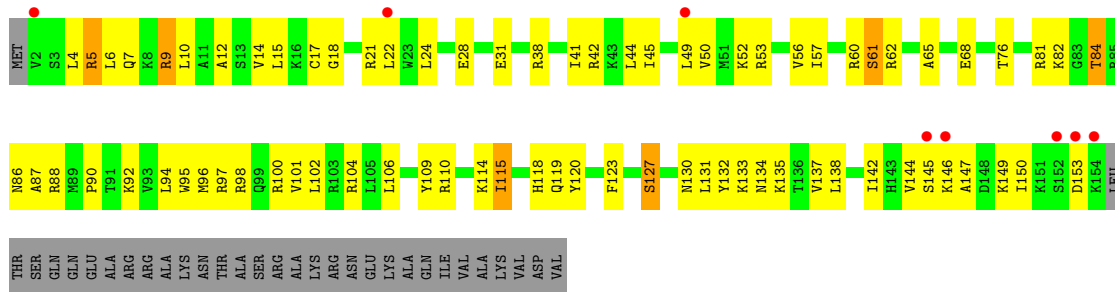

• Molecule 37: 60S RIBOSOMAL PROTEIN L21

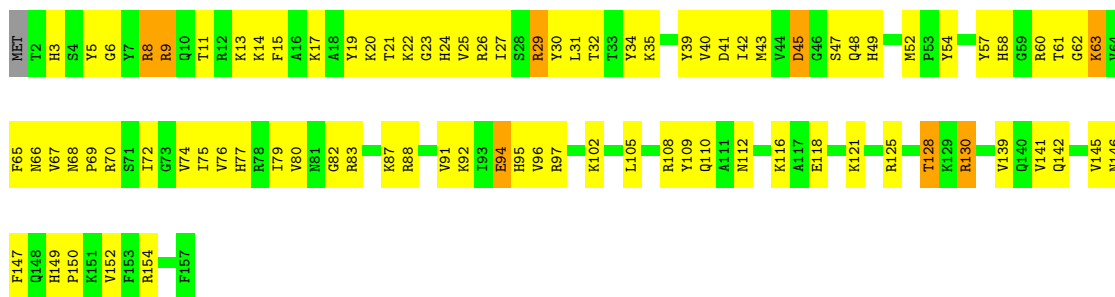

• Molecule 37: 60S RIBOSOMAL PROTEIN L21

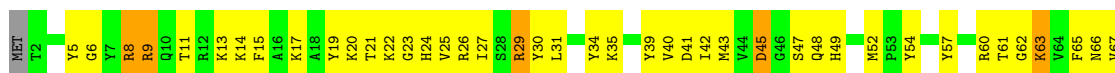

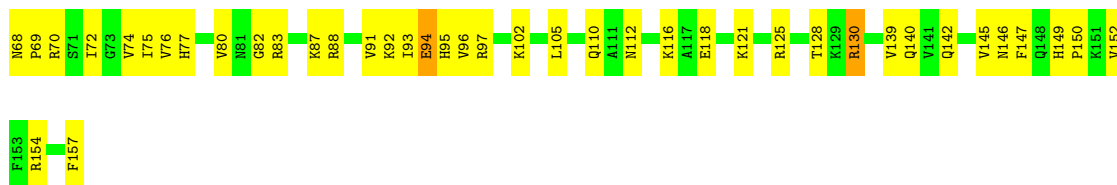

• Molecule 37: 60S RIBOSOMAL PROTEIN L21

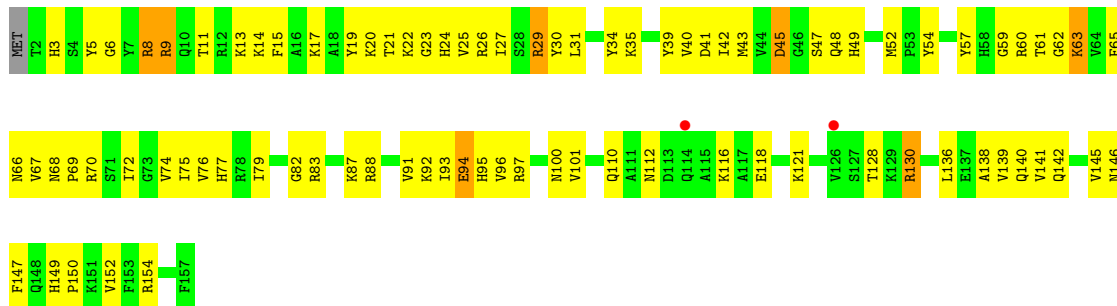

• Molecule 37: 60S RIBOSOMAL PROTEIN L21

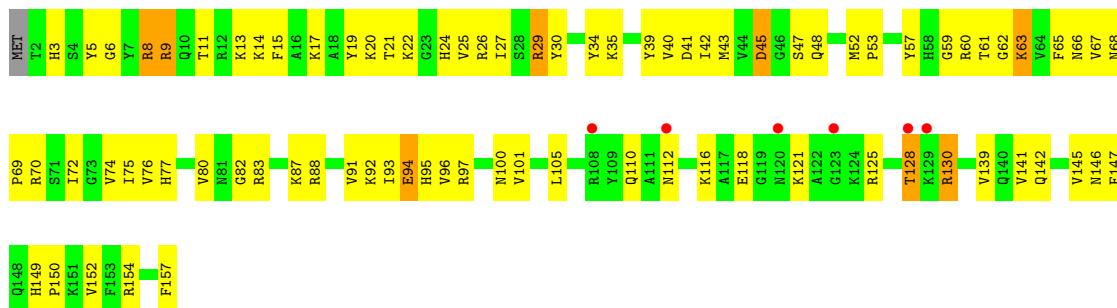

• Molecule 38: RPL17

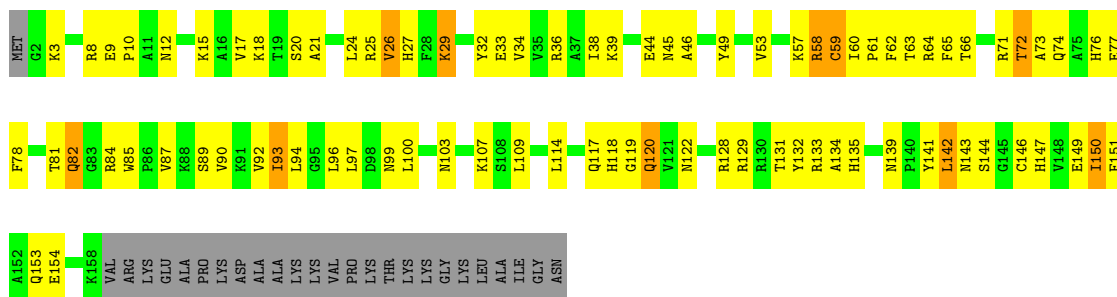

• Molecule 38: RPL17





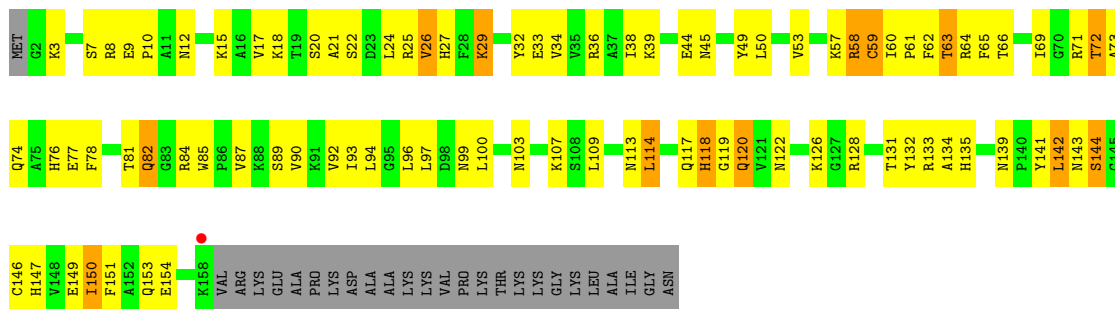

- Molecule 38: RPL17

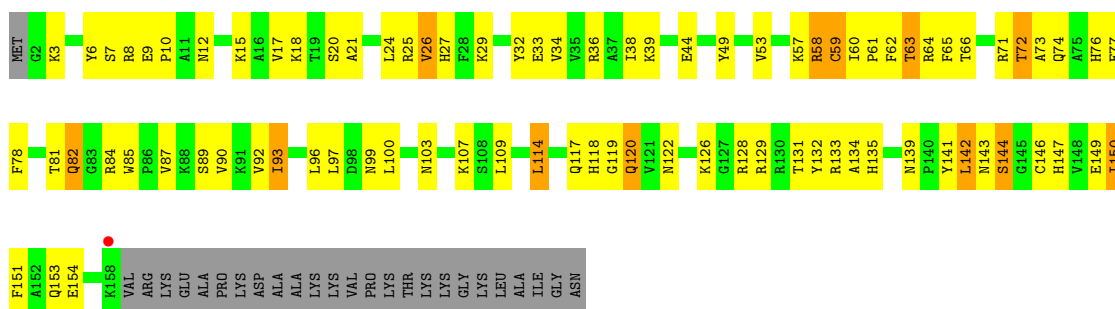

- Molecule 38: RPL17

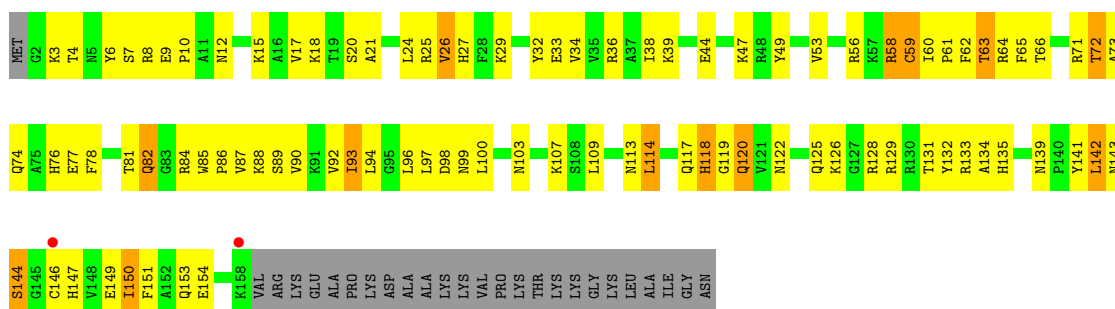

- Molecule 39: RPL23A

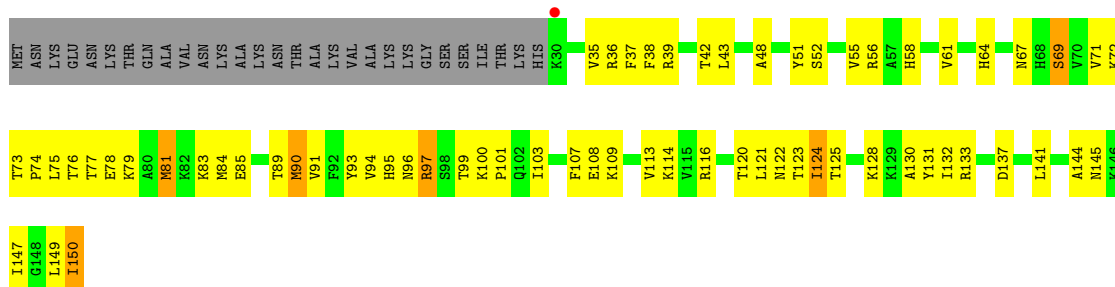

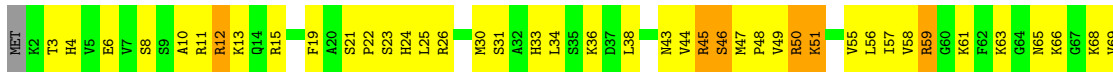

## ● Molecule 40: RPL26

Chain CS:  3% 39% 49% 6% 7%

## ● Molecule 40: RPL26

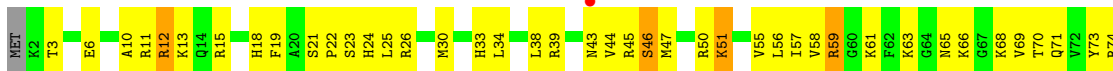
Chain ES:  4% 41% 48% 7%

## ● Molecule 40: RPL26

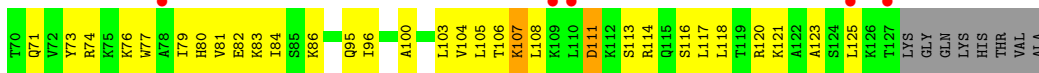
Chain GS:  7% 40% 47% 6% 7%

## ● Molecule 41: RPL24

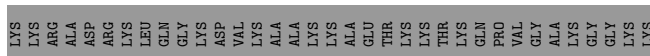
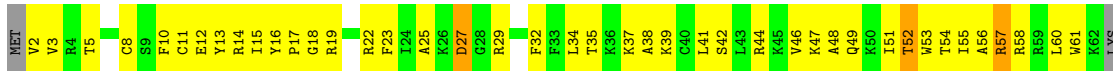
Chain BT:  12% 25% 61%

## ● Molecule 41: RPL24

Chain CT:  11% 25% 61%

VAL  
LYS  
LYS  
ALA  
THR  
R4  
ASP  
ASP  
ILE  
ALA  
GLN  
LYS  
GLN  
LYS  
LYS  
LYS  
LYS  
LYS  
LYS  
LYS  
VAL  
VAL  
THR  
VAL  
LYS  
LYS  
ALA  
ALA  
ARG  
ALA  
ALA  
ILE  
THR  
VAL  
GLY  
GLY  
ILE  
K26  
THR  
LYS  
SER  
LEU  
GLN  
PRO  
GLU  
GLU  
VAL  
VAL  
GLY  
ILE  
ALA  
ASN  
ARG  
LYS  
ARG  
ARG  
LYS  
ASN  
LEU  
ASP  
ALA  
ALA  
SER  
HIS  
LYS  
LYS  
LYS  
ALA  
ALA  
VAL  
ARG  
GLU  
LEU  
LEU  
GLU  
GLU

LYS  
LYS  
ARG  
ALA  
ALA  
ASP  
ASP  
LYS  
LYS  
LEU  
GLN  
GLY  
GLY  
ASP  
VAL  
VAL  
LYS  
LYS  
ALA  
ALA  
ALA  
GLU  
THR  
LYS  
LYS  
GLY  
GLY  
THR  
LYS  
LYS  
GLN  
PRO  
GLU  
VAL  
VAL  
GLY  
ILE  
ALA  
ASN  
ARG  
LYS  
ARG  
ARG  
GLY  
GLY  
LYS

- Molecule 41: RPL24

Chain ET: 11% 25% 61%

MET  
V2  
V3  
R4  
T5  
C8  
S9  
F10  
C11  
E12  
Y13  
R14  
I15  
Y16  
P17  
G18  
R19  
R22  
F23  
I24  
A25  
K26  
D27  
G28  
R29  
F32  
F33  
F33  
L34  
T35  
K36  
K37  
A38  
K39  
C40  
L41  
S42  
L43  
R44  
K45  
V46  
K47  
A48  
Q49  
K50  
I51  
T52  
W53  
T54  
I55  
A56  
R57  
R58  
R59  
L60  
W61  
K62  
LYS

VAL  
LYS  
LYS  
THR  
ASP  
ASP  
ILE  
ALA  
GLN  
LYS  
GLN  
LYS  
GLY  
LYS  
LYS  
ASP  
VAL  
VAL  
LYS  
LYS  
VAL  
VAL  
THR  
VAL  
LYS  
LYS  
ALA  
ALA  
ARG  
GLU  
THR  
ILE  
ALA  
VAL  
GLY  
GLY  
ILE  
K26  
THR  
LYS  
SER  
LEU  
GLN  
PRO  
GLU  
VAL  
VAL  
GLY  
ILE  
ALA  
ASN  
ARG  
LYS  
ARG  
ARG  
LYS  
GLY  
GLY  
LYS

LYS  
LYS  
ARG  
ALA  
ASP  
ASP  
LYS  
LYS  
LEU  
GLN  
GLY  
LYS  
LYS  
ASP  
VAL  
VAL  
LYS  
LYS  
VAL  
VAL  
THR  
VAL  
LYS  
LYS  
ALA  
ALA  
ARG  
GLU  
THR  
ILE  
ALA  
VAL  
GLY  
GLY  
ILE  
K26  
THR  
LYS  
SER  
LEU  
GLN  
PRO  
GLU  
VAL  
VAL  
GLY  
ILE  
ALA  
ASN  
ARG  
LYS  
ARG  
ARG  
LYS  
GLY  
GLY  
LYS

- Molecule 41: RPL24

Chain GT: 13% 23% 61%

MET  
V2  
T5  
C8  
S9  
F10  
C11  
E12  
Y13  
R14  
I15  
Y16  
P17  
G18  
R19  
R22  
F23  
I24  
A25  
K26  
D27  
G28  
R29  
F32  
F33  
F33  
L34  
T35  
K36  
K37  
A38  
K39  
C40  
L41  
S42  
L43  
R44  
K45  
V46  
K47  
A48  
Q49  
K50  
I51  
T52  
W53  
T54  
I55  
A56  
R57  
R58  
R59  
L60  
W61  
K62  
VAL

LYS  
ALA  
THR  
ASP  
ILE  
ALA  
GLN  
LYS  
LYS  
LYS  
GLY  
LYS  
ASP  
VAL  
VAL  
LYS  
LYS  
VAL  
VAL  
THR  
VAL  
LYS  
LYS  
ALA  
ALA  
ARG  
GLU  
THR  
ILE  
ALA  
VAL  
GLY  
GLY  
ILE  
K26  
THR  
LYS  
SER  
LEU  
GLN  
PRO  
GLU  
VAL  
VAL  
GLY  
ILE  
ALA  
ASN  
ARG  
LYS  
ARG  
ARG  
LYS  
GLY  
GLY  
LYS

LYS  
ARG  
ALA  
ASP  
ARG  
LYS  
LEU  
GLN  
GLY  
LYS  
LYS  
ASP  
VAL  
VAL  
LYS  
LYS  
VAL  
VAL  
THR  
VAL  
LYS  
LYS  
ALA  
ALA  
ARG  
GLU  
THR  
ILE  
ALA  
VAL  
GLY  
GLY  
ILE  
K26  
THR  
LYS  
SER  
LEU  
GLN  
PRO  
GLU  
VAL  
VAL  
GLY  
ILE  
ALA  
ASN  
ARG  
LYS  
ARG  
ARG  
LYS  
GLY  
GLY  
LYS

- Molecule 42: RPL35

Chain BU: 39% 54% 6%

MET  
D2  
K3  
R11  
T12  
Q13  
E14  
H15  
Q17  
G20  
E21  
L22  
G23  
K24  
L25  
E28  
L32  
R33  
I34  
A35  
K36  
I37  
T41  
A42  
M43  
K44  
L45  
G46  
R47  
I48  
V51  
R52  
K53  
A54  
I55  
Y58  
L59  
T60  
I61  
I62  
N63  
E64  
K65  
R66  
R67  
Q68  
A69  
D72  
Q73  
F74  
K75

G76  
K77  
S78  
L79  
K80  
P81  
L82  
D83  
I84  
R85  
E86  
Q87  
K88  
T89  
R90  
A91  
R92  
R93  
R94  
K95  
L96  
T97  
K98  
K99  
Q100  
R101  
E102  
A103  
V104  
L105  
T108  
Q109  
N113  
R118  
K119  
F120  
R121  
L122  
K123  
I124

- Molecule 42: RPL35

Chain CU: 37% 55% 7%

MET  
D2  
K3  
V7  
R11  
T12  
Q13  
E14  
H15  
Q17  
G20  
E21  
L22  
G23  
K24  
L25  
E28  
L32  
R33  
I34  
A35  
K36  
I37  
T41  
A42  
M43  
K44  
L45  
G46  
R47  
I48  
V51  
R52  
K53  
A54  
I55  
Y58  
L59  
T60  
I61  
I62  
N63  
E64  
K65  
R66  
R67  
Q68  
A69  
D72

Q73  
F74  
K75  
G76  
S77  
R78  
L79  
K80  
P81  
R80  
L82  
D83  
I84  
R85  
E86  
Q87  
K88  
T89  
R90  
A91  
R92  
R93  
R94  
K95  
L96  
T97  
K98  
K99  
Q100  
R101  
E102  
A103  
V104  
L105  
T108  
Q109  
N113  
R118  
K119  
R120  
F120  
A121  
L122  
K123  
I124

- Molecule 42: RPL35

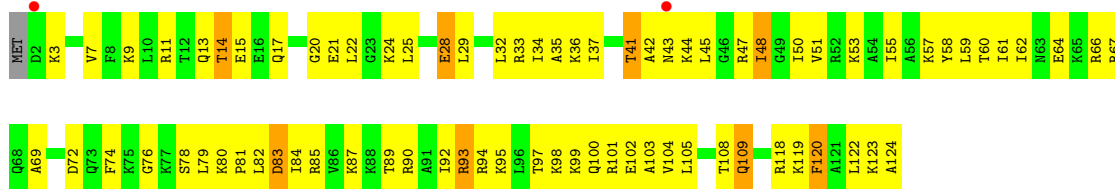

• Molecule 42: RPL35

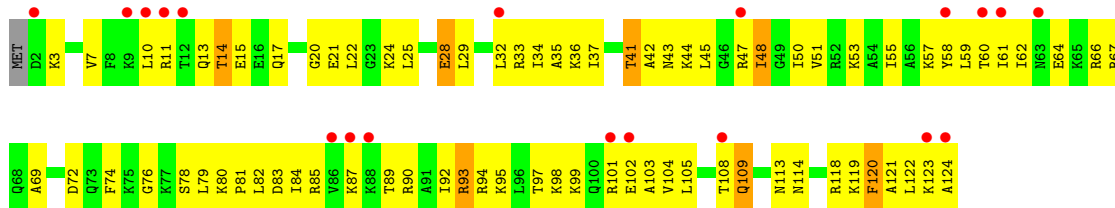

• Molecule 43: 60S RIBOSOMAL PROTEIN L7

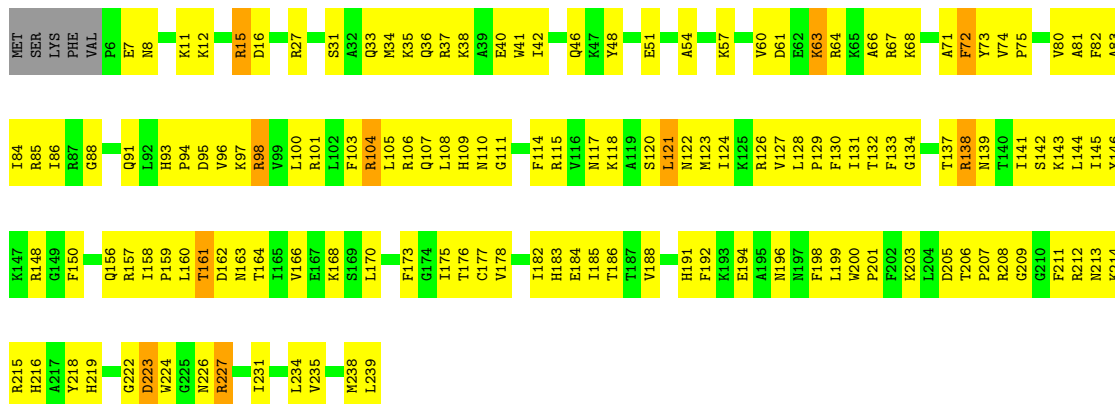

• Molecule 43: 60S RIBOSOMAL PROTEIN L7

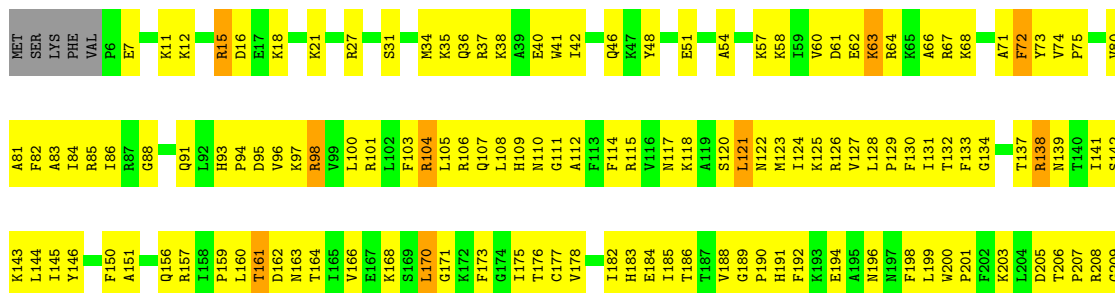



• Molecule 43: 60S RIBOSOMAL PROTEIN L7

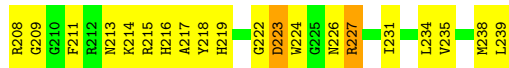
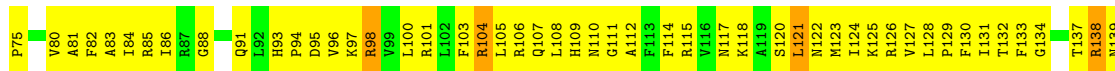

• Molecule 43: 60S RIBOSOMAL PROTEIN L7

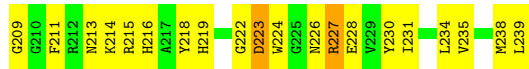
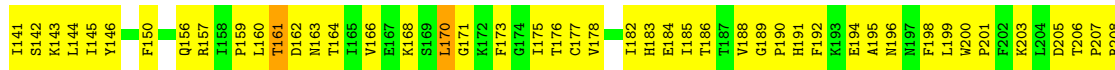
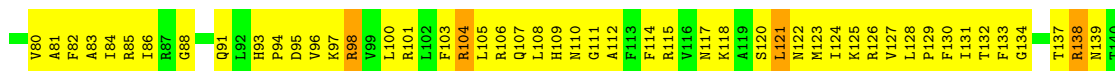

• Molecule 44: 60S RIBOSOMAL PROTEIN L31

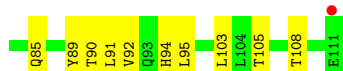
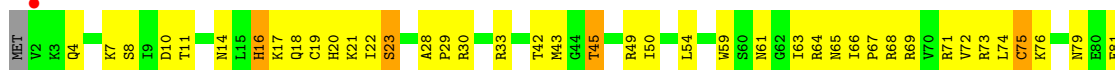

• Molecule 44: 60S RIBOSOMAL PROTEIN L31



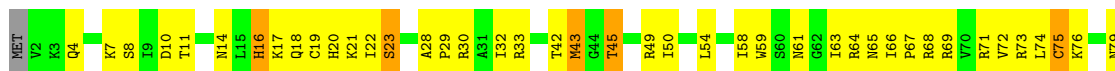

• Molecule 44: 60S RIBOSOMAL PROTEIN L31



• Molecule 44: 60S RIBOSOMAL PROTEIN L31

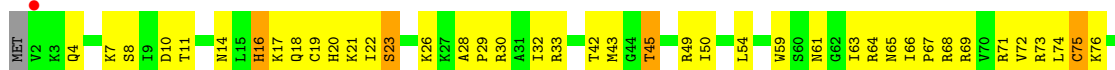

• Molecule 45: 60S RIBOSOMAL PROTEIN L32



• Molecule 45: 60S RIBOSOMAL PROTEIN L32



• Molecule 45: 60S RIBOSOMAL PROTEIN L32

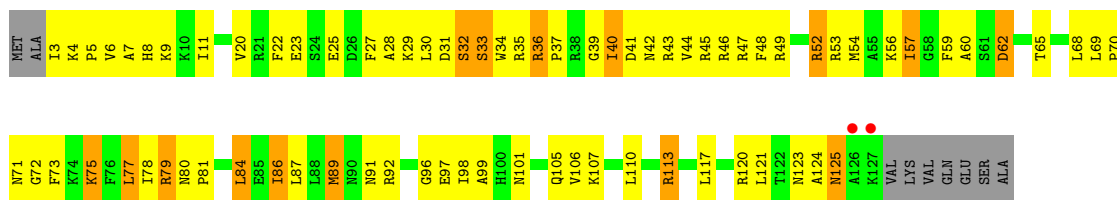

• Molecule 45: 60S RIBOSOMAL PROTEIN L32

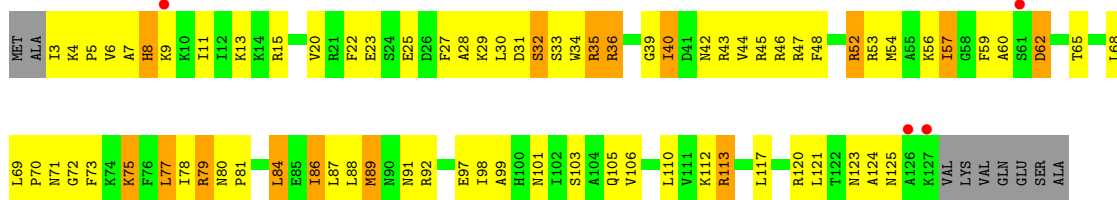

• Molecule 46: RPL37A

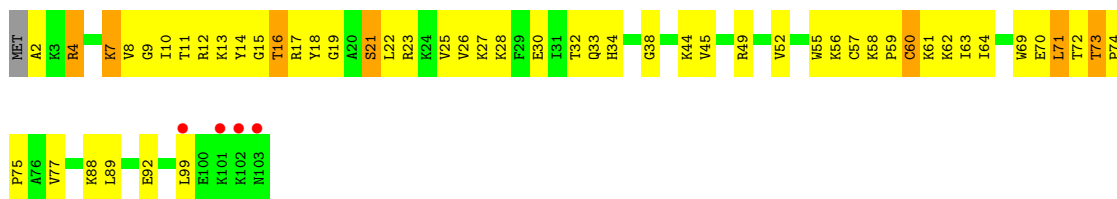

• Molecule 46: RPL37A



• Molecule 46: RPL37A

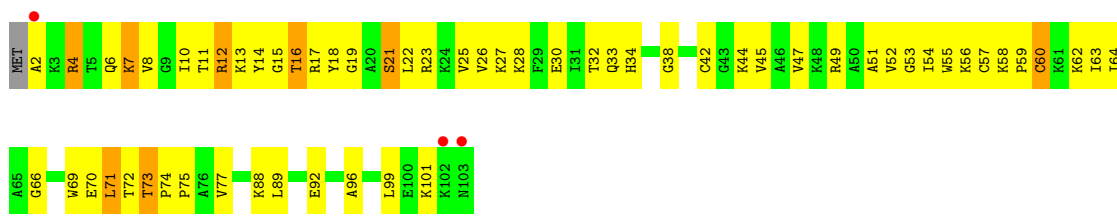



- Molecule 46: RPL37A

Chain GY:  4% 41% 52% 6%

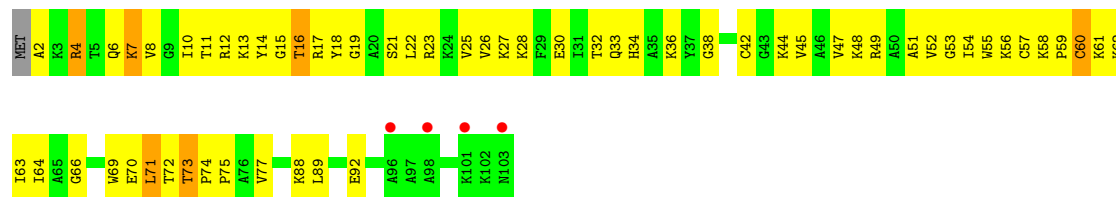

- Molecule 47: RPL19

Chain CO:  44% 48% 5%

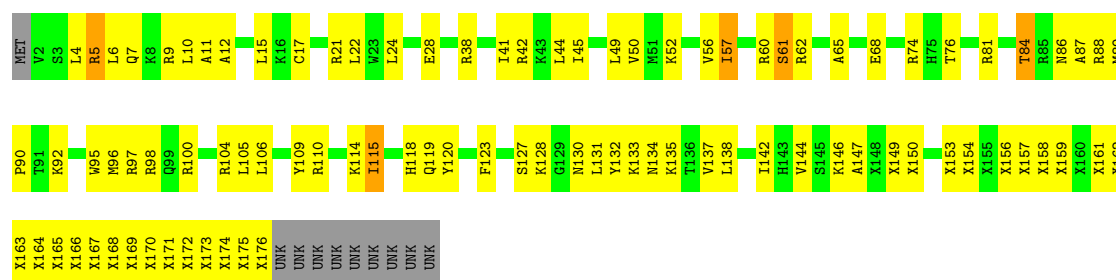

## 4 Data and refinement statistics i

Property	Value	Source
Space group	P 1 21 1	Depositor
Cell constants a, b, c, $\alpha$ , $\beta$ , $\gamma$	320.19Å 289.25Å 535.04Å 90.00° 91.22° 90.00°	Depositor
Resolution (Å)	20.00 – 3.52 39.96 – 3.52	Depositor EDS
% Data completeness (in resolution range)	99.4 (20.00-3.52) 99.4 (39.96-3.52)	Depositor EDS
$R_{merge}$	0.13	Depositor
$R_{sym}$	(Not available)	Depositor
$\langle I/\sigma(I) \rangle$ <sup>1</sup>	1.87 (at 3.48Å)	Xtrriage
Refinement program	PHENIX (PHENIX.REFINE)	Depositor
R, $R_{free}$	0.216 , 0.244 0.238 , 0.263	Depositor DCC
$R_{free}$ test set	10000 reflections (0.84%)	wwPDB-VP
Wilson B-factor (Å <sup>2</sup> )	96.9	Xtrriage
Anisotropy	0.228	Xtrriage
Bulk solvent $k_{sol}$ (e/Å <sup>3</sup> ), $B_{sol}$ (Å <sup>2</sup> )	0.27 , 73.9	EDS
L-test for twinning <sup>2</sup>	$\langle  L  \rangle = 0.45$ , $\langle L^2 \rangle = 0.28$	Xtrriage
Estimated twinning fraction	0.028 for h,-k,-l	Xtrriage
$F_o, F_c$ correlation	0.91	EDS
Total number of atoms	511395	wwPDB-VP
Average B, all atoms (Å <sup>2</sup> )	108.0	wwPDB-VP

Xtrriage's analysis on translational NCS is as follows: *The largest off-origin peak in the Patterson function is 1.51% of the height of the origin peak. No significant pseudotranslation is detected.*

<sup>1</sup>Intensities estimated from amplitudes.

<sup>2</sup>Theoretical values of  $\langle |L| \rangle$ ,  $\langle L^2 \rangle$  for acentric reflections are 0.5, 0.333 respectively for untwinned datasets, and 0.375, 0.2 for perfectly twinned datasets.

## 5 Model quality

### 5.1 Standard geometry

Bond lengths and bond angles in the following residue types are not validated in this section: MG, ZN

The Z score for a bond length (or angle) is the number of standard deviations the observed value is removed from the expected value. A bond length (or angle) with  $|Z| > 5$  is considered an outlier worth inspection. RMSZ is the root-mean-square of all Z scores of the bond lengths (or angles).

Mol	Chain	Bond lengths		Bond angles	
		RMSZ	# Z  >5	RMSZ	# Z  >5
1	A1	0.75	14/74792 (0.0%)	1.12	353/116594 (0.3%)
1	D1	0.82	60/74792 (0.1%)	1.14	368/116594 (0.3%)
1	F1	0.74	57/74792 (0.1%)	1.12	384/116594 (0.3%)
1	H1	0.78	8/74792 (0.0%)	1.15	436/116594 (0.4%)
2	AA	0.64	1/734 (0.1%)	0.77	0/972
2	DA	0.63	0/734	0.76	0/972
2	FA	0.61	1/734 (0.1%)	0.75	0/972
2	HA	0.63	0/734	0.77	0/972
3	AB	0.54	0/466	0.62	0/619
3	DB	0.46	0/466	0.62	0/619
3	FB	0.48	0/466	0.62	0/619
3	HB	0.51	0/466	0.62	0/619
4	AC	0.58	0/848	0.71	1/1123 (0.1%)
4	DC	0.53	0/848	0.69	0/1123
4	FC	0.54	0/848	0.70	0/1123
4	HC	0.57	0/848	0.71	1/1123 (0.1%)
5	AE	0.47	0/1550	0.74	2/2077 (0.1%)
5	DE	0.47	0/1550	0.74	2/2077 (0.1%)
5	FE	0.48	0/1550	0.75	2/2077 (0.1%)
5	HE	0.47	0/1550	0.75	2/2077 (0.1%)
6	AF	0.51	0/1033	0.71	0/1380
6	DF	0.51	0/1033	0.71	0/1380
6	FF	0.53	0/1033	0.71	0/1380
6	HF	0.53	0/1033	0.72	0/1380
7	AG	0.50	0/736	0.74	0/990
7	DG	0.47	0/736	0.73	0/990
7	FG	0.47	0/736	0.72	0/990
7	HG	0.46	0/736	0.72	0/990
8	AH	0.63	0/870	0.81	0/1175
8	DH	0.62	0/870	0.82	0/1175
8	FH	0.63	0/870	0.81	0/1175
8	HH	0.58	0/870	0.81	0/1175

Mol	Chain	Bond lengths		Bond angles	
		RMSZ	# Z  >5	RMSZ	# Z  >5
9	AJ	0.51	0/1739	0.70	0/2368
9	DJ	0.49	0/1739	0.70	0/2368
9	FJ	0.53	0/1739	0.70	0/2368
9	HJ	0.54	0/1739	0.70	0/2368
10	AK	0.48	0/421	0.69	0/558
10	DK	0.45	0/421	0.70	0/558
10	FK	0.46	0/421	0.69	0/558
10	HK	0.48	0/421	0.71	0/558
11	AL	0.64	0/861	0.77	1/1154 (0.1%)
11	DL	0.57	0/861	0.72	0/1154
11	FL	0.51	0/861	0.73	0/1154
11	HL	0.51	0/861	0.74	0/1154
12	AM	0.41	0/832	0.67	0/1113
12	DM	0.41	0/832	0.67	0/1113
12	FM	0.41	0/832	0.67	0/1113
12	HM	0.42	0/832	0.66	0/1113
13	AN	0.43	0/1190	0.63	1/1582 (0.1%)
13	DN	0.38	0/1190	0.58	0/1582
13	FN	0.38	0/1190	0.58	0/1582
13	HN	0.38	0/1190	0.58	0/1582
14	AO	0.47	0/1047	0.77	1/1400 (0.1%)
14	DO	0.47	0/1047	0.77	1/1400 (0.1%)
14	FO	0.46	0/1047	0.76	1/1400 (0.1%)
14	HO	0.51	0/1047	0.78	1/1400 (0.1%)
15	AP	0.41	0/561	0.61	0/745
15	DP	0.38	0/561	0.62	0/745
15	FP	0.40	0/561	0.60	0/745
15	HP	0.40	0/561	0.62	0/745
16	AQ	0.48	0/808	0.70	0/1068
16	DQ	0.48	0/808	0.69	0/1068
16	FQ	0.49	0/808	0.73	0/1068
16	HQ	0.50	0/808	0.70	0/1068
17	AT	0.48	0/539	0.72	0/711
17	DT	0.48	0/539	0.72	0/711
17	FT	0.49	0/539	0.71	0/711
17	HT	0.52	0/539	0.72	0/711
18	AU	0.53	0/1647	0.74	1/2201 (0.0%)
18	DU	0.51	0/1647	0.74	1/2201 (0.0%)
18	FU	0.54	0/1647	0.74	1/2201 (0.0%)
18	HU	0.58	0/1647	0.74	1/2201 (0.0%)
19	AX	0.48	0/1563	0.74	0/2104
19	DX	0.50	0/1563	0.75	1/2104 (0.0%)
19	FX	0.49	0/1563	0.74	0/2104

Mol	Chain	Bond lengths		Bond angles	
		RMSZ	# Z  >5	RMSZ	# Z  >5
19	HX	0.50	0/1563	0.74	2/2104 (0.1%)
20	B2	0.69	0/3696	1.06	10/5761 (0.2%)
20	C2	0.69	0/3696	1.07	7/5761 (0.1%)
20	E2	0.63	0/3696	1.07	10/5761 (0.2%)
20	G2	0.86	1/3696 (0.0%)	1.17	24/5761 (0.4%)
21	B3	0.70	0/2870	0.96	7/4473 (0.2%)
21	C3	0.61	0/2870	0.97	5/4473 (0.1%)
21	E3	0.59	0/2870	0.95	4/4473 (0.1%)
21	G3	0.63	0/2870	0.98	10/4473 (0.2%)
22	BA	0.63	0/2019	0.79	1/2712 (0.0%)
22	CA	0.61	0/2019	0.77	1/2712 (0.0%)
22	EA	0.61	0/2019	0.77	1/2712 (0.0%)
22	GA	0.60	0/2019	0.76	1/2712 (0.0%)
23	BB	0.56	0/3144	0.72	0/4213
23	CB	0.54	0/3144	0.71	0/4213
23	EB	0.54	0/3144	0.71	0/4213
23	GB	0.52	0/3144	0.72	0/4213
24	BC	0.47	0/3222	0.67	0/4338
24	CC	0.49	0/3222	0.68	0/4338
24	EC	0.49	0/3222	0.68	0/4338
24	GC	0.53	0/3222	0.69	1/4338 (0.0%)
25	BD	0.48	0/1376	0.66	0/1833
25	CD	0.45	0/1376	0.66	0/1833
25	ED	0.46	0/1376	0.66	0/1833
25	GD	0.47	0/1376	0.67	0/1833
26	BE	0.49	0/1501	0.72	2/2015 (0.1%)
26	CE	0.48	0/1501	0.72	2/2015 (0.1%)
26	EE	0.50	0/1501	0.72	1/2015 (0.0%)
26	GE	0.50	0/1501	0.74	2/2015 (0.1%)
27	BF	0.48	0/1893	0.66	0/2548
27	CF	0.48	0/1893	0.66	0/2548
27	EF	0.48	0/1893	0.65	0/2548
27	GF	0.49	0/1893	0.66	0/2548
29	BH	0.48	0/1652	0.68	0/2213
29	CH	0.48	0/1652	0.66	0/2213
29	EH	0.46	0/1652	0.66	0/2213
29	GH	0.46	0/1652	0.67	0/2213
30	BI	0.48	0/1624	0.66	0/2176
30	CI	0.49	0/1624	0.68	0/2176
30	EI	0.49	0/1624	0.66	0/2176
30	GI	0.87	6/1624 (0.4%)	0.92	7/2176 (0.3%)
31	BJ	0.64	1/1038 (0.1%)	0.77	0/1394
31	CJ	0.67	1/1038 (0.1%)	0.77	1/1394 (0.1%)

Mol	Chain	Bond lengths		Bond angles	
		RMSZ	# Z  >5	RMSZ	# Z  >5
31	EJ	0.64	1/1038 (0.1%)	0.76	0/1394
31	GJ	0.68	1/1038 (0.1%)	0.77	2/1394 (0.1%)
32	BK	0.53	0/1189	0.71	0/1589
32	CK	0.53	0/1189	0.73	1/1589 (0.1%)
32	EK	0.52	0/1189	0.73	1/1589 (0.1%)
32	GK	0.58	0/1189	0.74	0/1589
33	BL	0.53	0/1727	0.71	0/2308
33	CL	0.53	0/1727	0.71	0/2308
33	EL	0.53	0/1727	0.72	0/2308
33	GL	0.59	0/1727	0.73	0/2308
34	BM	0.49	0/2453	0.70	1/3285 (0.0%)
34	CM	0.48	0/2469	0.69	1/3306 (0.0%)
34	EM	0.54	1/2469 (0.0%)	0.71	1/3306 (0.0%)
34	GM	0.53	1/2469 (0.0%)	0.72	1/3306 (0.0%)
35	BN	0.54	0/1464	0.77	1/1965 (0.1%)
35	CN	0.52	0/1464	0.77	0/1965
35	EN	0.53	0/1464	0.76	0/1965
35	GN	0.60	0/1464	0.78	1/1965 (0.1%)
36	BO	0.58	0/1507	0.67	0/2001
36	EO	0.44	0/1208	0.62	0/1604
36	GO	0.50	0/1250	0.65	0/1660
37	BP	0.53	0/1300	0.64	0/1743
37	CP	0.49	0/1300	0.62	0/1743
37	EP	0.50	0/1300	0.63	0/1743
37	GP	0.54	0/1300	0.64	0/1743
38	BQ	0.60	0/1259	0.77	0/1693
38	CQ	0.57	0/1259	0.75	1/1693 (0.1%)
38	EQ	0.55	0/1259	0.75	1/1693 (0.1%)
38	GQ	0.56	0/1259	0.78	1/1693 (0.1%)
39	BR	0.52	0/981	0.67	0/1320
39	CR	0.47	0/981	0.66	0/1320
39	ER	0.46	0/981	0.66	0/1320
39	GR	0.52	0/981	0.67	0/1320
40	BS	0.44	0/1028	0.62	0/1372
40	CS	0.42	0/1028	0.61	0/1372
40	ES	0.44	0/1028	0.61	0/1372
40	GS	0.50	0/1028	0.63	0/1372
41	BT	0.60	0/521	0.72	0/693
41	CT	0.57	0/521	0.69	0/693
41	ET	0.55	0/521	0.71	0/693
41	GT	0.53	0/521	0.70	0/693
42	BU	0.44	0/995	0.65	0/1318
42	CU	0.44	0/995	0.64	0/1318

Mol	Chain	Bond lengths		Bond angles	
		RMSZ	# Z  >5	RMSZ	# Z  >5
42	EU	0.44	0/995	0.65	0/1318
42	GU	0.51	0/995	0.66	0/1318
43	BV	0.48	0/1950	0.66	0/2614
43	CV	0.49	0/1950	0.67	1/2614 (0.0%)
43	EV	0.50	0/1950	0.67	1/2614 (0.0%)
43	GV	0.49	0/1950	0.66	1/2614 (0.0%)
44	BW	0.60	0/913	0.68	0/1222
44	CW	0.55	0/913	0.68	0/1222
44	EW	0.51	0/913	0.67	0/1222
44	GW	0.51	0/913	0.68	0/1222
45	BX	0.48	0/1028	0.67	0/1371
45	CX	0.51	0/1028	0.67	0/1371
45	EX	0.47	0/1028	0.67	0/1371
45	GX	0.56	0/1028	0.68	0/1371
46	BY	0.60	0/799	0.79	0/1069
46	CY	0.60	0/799	0.75	0/1069
46	EY	0.57	0/799	0.76	0/1069
46	GY	0.55	0/799	0.75	0/1069
47	CO	0.46	0/1208	0.63	0/1604
All	All	0.68	154/540737 (0.0%)	0.99	1677/795620 (0.2%)

Chiral center outliers are detected by calculating the chiral volume of a chiral center and verifying if the center is modelled as a planar moiety or with the opposite hand. A planarity outlier is detected by checking planarity of atoms in a peptide group, atoms in a mainchain group or atoms of a sidechain that are expected to be planar.

Mol	Chain	#Chirality outliers	#Planarity outliers
2	AA	0	1
2	DA	0	1
2	FA	0	1
2	HA	0	1
8	AH	0	1
12	AM	0	1
12	DM	0	1
12	FM	0	1
12	HM	0	1
16	AQ	0	1
16	DQ	0	1
16	FQ	0	1
16	HQ	0	1
18	FU	0	1
27	BF	0	1

*Continued on next page...*

Continued from previous page...

Mol	Chain	#Chirality outliers	#Planarity outliers
27	CF	0	1
27	EF	0	1
27	GF	0	1
32	BK	0	2
32	CK	0	2
32	EK	0	2
32	GK	0	2
38	CQ	0	1
38	GQ	0	1
42	CU	0	1
45	GX	0	1
All	All	0	30

The worst 5 of 154 bond length outliers are listed below:

Mol	Chain	Res	Type	Atoms	Z	Observed(Å)	Ideal(Å)
1	F1	2239	A	O3'-P	25.66	1.92	1.61
30	GI	60	TRP	NE1-CE2	-18.39	1.13	1.37
1	D1	2254	A	C5-C4	17.31	1.50	1.38
1	D1	2254	A	N7-C5	15.90	1.48	1.39
1	D1	2254	A	N3-C4	15.68	1.44	1.34

The worst 5 of 1677 bond angle outliers are listed below:

Mol	Chain	Res	Type	Atoms	Z	Observed(°)	Ideal(°)
1	F1	2253	U	C5-C6-N1	-21.57	111.92	122.70
30	GI	60	TRP	CE2-CD2-CG	-18.64	92.39	107.30
1	D1	284	U	C6-N1-C2	-15.54	111.67	121.00
1	F1	119	A	N1-C6-N6	15.41	127.85	118.60
1	H1	1053	A	C6-N1-C2	-15.06	109.57	118.60

There are no chirality outliers.

5 of 30 planarity outliers are listed below:

Mol	Chain	Res	Type	Group
2	AA	51	GLY	Peptide
8	AH	101	GLY	Peptide
12	AM	53	GLY	Peptide
16	AQ	12	GLY	Peptide
27	BF	174	LYS	Peptide



## 5.2 Too-close contacts

In the following table, the Non-H and H(model) columns list the number of non-hydrogen atoms and hydrogen atoms in the chain respectively. The H(added) column lists the number of hydrogen atoms added and optimized by MolProbity. The Clashes column lists the number of clashes within the asymmetric unit, whereas Symm-Clashes lists symmetry-related clashes.

Mol	Chain	Non-H	H(model)	H(added)	Clashes	Symm-Clashes
1	A1	66769	0	33570	4643	2
1	D1	66769	0	33568	4655	1
1	F1	66769	0	33568	4661	3
1	H1	66769	0	33570	4682	4
2	AA	721	0	744	102	0
2	DA	721	0	744	103	0
2	FA	721	0	744	110	0
2	HA	721	0	744	114	0
3	AB	456	0	483	51	0
3	DB	456	0	483	52	0
3	FB	456	0	483	53	0
3	HB	456	0	483	51	0
4	AC	836	0	912	64	0
4	DC	836	0	911	62	0
4	FC	836	0	911	65	0
4	HC	836	0	911	67	0
5	AE	1525	0	1600	230	0
5	DE	1525	0	1600	225	0
5	FE	1525	0	1600	221	0
5	HE	1525	0	1600	231	0
6	AF	1021	0	1119	147	0
6	DF	1021	0	1119	152	0
6	FF	1021	0	1119	152	0
6	HF	1021	0	1119	152	0
7	AG	727	0	747	103	0
7	DG	727	0	747	92	0
7	FG	727	0	747	88	0
7	HG	727	0	747	88	0
8	AH	850	0	870	134	0
8	DH	850	0	870	139	0
8	FH	850	0	870	139	0
8	HH	850	0	870	129	0
9	AJ	1716	0	1712	162	0
9	DJ	1716	0	1712	181	0
9	FJ	1716	0	1712	178	0
9	HJ	1716	0	1712	176	0
10	AK	415	0	446	42	0

*Continued on next page...*

*Continued from previous page...*

Mol	Chain	Non-H	H(model)	H(added)	Clashes	Symm-Clashes
10	DK	415	0	446	38	0
10	FK	415	0	446	36	0
10	HK	415	0	446	35	0
11	AL	852	0	906	90	0
11	DL	852	0	906	94	0
11	FL	852	0	906	88	0
11	HL	852	0	906	90	0
12	AM	819	0	855	75	0
12	DM	819	0	855	73	0
12	FM	819	0	855	77	0
12	HM	819	0	855	74	0
13	AN	1170	0	1259	156	0
13	DN	1170	0	1259	134	0
13	FN	1170	0	1259	155	0
13	HN	1170	0	1259	134	0
14	AO	1034	0	1101	143	0
14	DO	1034	0	1101	127	0
14	FO	1034	0	1101	130	0
14	HO	1034	0	1101	119	0
15	AP	551	0	614	53	0
15	DP	551	0	614	57	2
15	FP	551	0	614	49	0
15	HP	551	0	614	58	0
16	AQ	803	0	907	87	2
16	DQ	803	0	907	98	0
16	FQ	803	0	907	100	0
16	HQ	803	0	907	82	0
17	AT	533	0	578	65	0
17	DT	533	0	578	55	0
17	FT	533	0	578	56	0
17	HT	533	0	578	62	0
18	AU	1624	0	1733	210	0
18	DU	1624	0	1733	215	0
18	FU	1624	0	1733	209	0
18	HU	1624	0	1733	236	0
19	AX	1536	0	1613	221	0
19	DX	1536	0	1613	220	0
19	FX	1536	0	1613	222	0
19	HX	1536	0	1613	211	0
20	B2	3300	0	1657	219	1
20	C2	3300	0	1657	225	0
20	E2	3300	0	1657	227	0

*Continued on next page...*

*Continued from previous page...*

Mol	Chain	Non-H	H(model)	H(added)	Clashes	Symm-Clashes
20	G2	3300	0	1657	234	0
21	B3	2566	0	1294	179	0
21	C3	2566	0	1294	195	0
21	E3	2566	0	1294	191	0
21	G3	2566	0	1294	187	0
22	BA	1977	0	2000	233	0
22	CA	1977	0	2000	221	0
22	EA	1977	0	2000	240	0
22	GA	1977	0	2000	247	0
23	BB	3080	0	3187	338	0
23	CB	3080	0	3187	332	0
23	EB	3080	0	3187	364	0
23	GB	3080	0	3187	361	0
24	BC	3172	0	3274	422	0
24	CC	3172	0	3274	428	0
24	EC	3172	0	3274	438	0
24	GC	3172	0	3274	443	0
25	BD	1357	0	1400	124	0
25	CD	1357	0	1400	123	0
25	ED	1357	0	1400	125	0
25	GD	1357	0	1400	127	0
26	BE	1481	0	1574	124	0
26	CE	1481	0	1574	119	0
26	EE	1481	0	1574	124	0
26	GE	1481	0	1574	123	0
27	BF	1860	0	1968	208	0
27	CF	1860	0	1968	217	0
27	EF	1860	0	1968	197	1
27	GF	1860	0	1968	208	0
28	BG	711	0	644	56	0
28	CG	711	0	644	44	0
28	EG	711	0	644	46	0
28	GG	711	0	644	86	0
29	BH	1620	0	1701	159	0
29	CH	1620	0	1701	155	0
29	EH	1620	0	1701	165	0
29	GH	1620	0	1701	160	0
30	BI	1594	0	1701	172	0
30	CI	1594	0	1701	179	0
30	EI	1594	0	1701	170	0
30	GI	1594	0	1701	179	0
31	BJ	1022	0	1078	65	0

*Continued on next page...*

*Continued from previous page...*

Mol	Chain	Non-H	H(model)	H(added)	Clashes	Symm-Clashes
31	CJ	1022	0	1079	64	0
31	EJ	1022	0	1079	70	0
31	GJ	1022	0	1078	71	0
32	BK	1161	0	1227	189	0
32	CK	1161	0	1227	180	0
32	EK	1161	0	1227	183	0
32	GK	1161	0	1227	195	0
33	BL	1691	0	1762	183	0
33	CL	1691	0	1762	187	0
33	EL	1691	0	1762	195	0
33	GL	1691	0	1762	203	0
34	BM	2409	0	2497	327	0
34	CM	2424	0	2509	312	1
34	EM	2424	0	2509	311	4
34	GM	2424	0	2509	286	2
35	BN	1441	0	1534	218	0
35	CN	1441	0	1534	232	0
35	EN	1441	0	1534	223	0
35	GN	1441	0	1534	234	0
36	BO	1491	0	1618	106	0
36	EO	1192	0	1296	87	0
36	GO	1234	0	1323	87	0
37	BP	1272	0	1310	136	0
37	CP	1272	0	1310	129	0
37	EP	1272	0	1310	137	0
37	GP	1272	0	1310	126	0
38	BQ	1239	0	1276	126	0
38	CQ	1239	0	1276	132	0
38	EQ	1239	0	1276	125	0
38	GQ	1239	0	1276	133	0
39	BR	965	0	1020	96	0
39	CR	965	0	1020	82	0
39	ER	965	0	1020	90	0
39	GR	965	0	1020	97	0
40	BS	1013	0	1101	90	0
40	CS	1013	0	1101	96	1
40	ES	1013	0	1101	94	0
40	GS	1013	0	1101	92	0
41	BT	510	0	546	51	0
41	CT	510	0	546	51	0
41	ET	510	0	546	59	0
41	GT	510	0	546	52	0

*Continued on next page...*

*Continued from previous page...*

Mol	Chain	Non-H	H(model)	H(added)	Clashes	Symm-Clashes
42	BU	990	0	1123	98	0
42	CU	990	0	1123	106	0
42	EU	990	0	1123	109	0
42	GU	990	0	1123	117	0
43	BV	1910	0	1983	203	0
43	CV	1910	0	1983	202	0
43	EV	1910	0	1983	212	0
43	GV	1910	0	1983	199	0
44	BW	901	0	937	65	0
44	CW	901	0	937	68	0
44	EW	901	0	937	70	0
44	GW	901	0	937	69	0
45	BX	1012	0	1079	110	0
45	CX	1012	0	1079	108	0
45	EX	1012	0	1079	114	0
45	GX	1012	0	1079	120	0
46	BY	786	0	851	83	0
46	CY	786	0	849	90	0
46	EY	786	0	851	105	0
46	GY	786	0	851	94	0
47	CO	1366	0	1470	140	0
48	A1	200	0	0	0	0
48	AA	2	0	0	0	0
48	AK	1	0	0	0	0
48	B2	8	0	0	0	0
48	B3	3	0	0	0	0
48	BJ	1	0	0	0	0
48	BL	1	0	0	0	0
48	BN	1	0	0	0	0
48	BP	1	0	0	0	0
48	BQ	2	0	0	0	0
48	BW	1	0	0	0	0
48	C2	6	0	0	0	0
48	C3	7	0	0	0	0
48	CD	1	0	0	0	0
48	CJ	1	0	0	0	0
48	CL	2	0	0	0	0
48	CN	1	0	0	0	0
48	CQ	2	0	0	0	0
48	CW	1	0	0	0	0
48	CY	1	0	0	0	0
48	D1	232	0	0	0	0

*Continued on next page...*

*Continued from previous page...*

Mol	Chain	Non-H	H(model)	H(added)	Clashes	Symm-Clashes
48	DA	2	0	0	0	0
48	DJ	1	0	0	0	0
48	DK	1	0	0	0	0
48	DQ	1	0	0	0	0
48	E2	7	0	0	0	0
48	E3	6	0	0	0	0
48	EJ	1	0	0	0	0
48	EL	2	0	0	0	0
48	EN	2	0	0	0	0
48	EQ	1	0	0	0	0
48	EW	2	0	0	0	0
48	F1	184	0	0	0	0
48	FA	2	0	0	0	0
48	FK	1	0	0	0	0
48	FT	1	0	0	0	0
48	G2	6	0	0	0	0
48	G3	5	0	0	0	0
48	GA	1	0	0	0	0
48	GJ	1	0	0	0	0
48	GL	1	0	0	0	0
48	GN	1	0	0	0	0
48	GO	1	0	0	0	0
48	GP	2	0	0	0	0
48	GQ	1	0	0	0	0
48	GW	1	0	0	0	0
48	H1	155	0	0	0	0
48	HT	1	0	0	0	0
49	AA	1	0	0	0	0
49	AC	1	0	0	0	0
49	AK	1	0	0	0	0
49	AL	1	0	0	0	0
49	BY	1	0	0	0	0
49	CY	1	0	0	0	0
49	DA	1	0	0	0	0
49	DC	1	0	0	0	0
49	DK	1	0	0	0	0
49	DL	1	0	0	0	0
49	EY	1	0	0	0	0
49	FA	1	0	0	0	0
49	FC	1	0	0	0	0
49	FK	1	0	0	0	0
49	FL	1	0	0	0	0

*Continued on next page...*

*Continued from previous page...*

Mol	Chain	Non-H	H(model)	H(added)	Clashes	Symm-Clashes
49	GY	1	0	0	0	0
49	HA	1	0	0	0	0
49	HC	1	0	0	0	0
49	HK	1	0	0	0	0
49	HL	1	0	0	0	0
50	A1	1134	0	0	292	0
50	AA	8	0	0	2	0
50	AB	5	0	0	2	0
50	AH	1	0	0	0	0
50	AK	3	0	0	1	0
50	AM	1	0	0	0	0
50	AP	2	0	0	0	0
50	AT	3	0	0	3	0
50	AU	4	0	0	3	0
50	B2	54	0	0	5	0
50	B3	23	0	0	6	0
50	BA	12	0	0	3	0
50	BB	4	0	0	1	0
50	BC	7	0	0	0	0
50	BE	1	0	0	0	0
50	BI	3	0	0	1	0
50	BJ	5	0	0	1	0
50	BK	3	0	0	1	0
50	BL	8	0	0	0	0
50	BM	2	0	0	1	0
50	BN	5	0	0	0	0
50	BO	2	0	0	2	0
50	BP	5	0	0	2	0
50	BQ	7	0	0	3	0
50	BU	1	0	0	0	0
50	BV	7	0	0	1	0
50	BW	5	0	0	0	0
50	BX	6	0	0	1	0
50	BY	5	0	0	0	0
50	C2	46	0	0	3	0
50	C3	39	0	0	10	0
50	CA	11	0	0	3	0
50	CB	4	0	0	0	0
50	CC	7	0	0	0	0
50	CD	4	0	0	0	0
50	CE	2	0	0	1	0
50	CI	1	0	0	0	0

*Continued on next page...*

*Continued from previous page...*

Mol	Chain	Non-H	H(model)	H(added)	Clashes	Symm-Clashes
50	CJ	4	0	0	3	0
50	CK	3	0	0	1	0
50	CL	12	0	0	2	0
50	CM	6	0	0	1	0
50	CN	7	0	0	5	0
50	CO	2	0	0	1	0
50	CP	6	0	0	1	0
50	CQ	7	0	0	5	0
50	CU	1	0	0	0	0
50	CV	4	0	0	1	0
50	CW	5	0	0	0	0
50	CX	6	0	0	0	0
50	CY	5	0	0	0	0
50	D1	1341	0	0	313	0
50	DA	10	0	0	1	0
50	DB	4	0	0	2	0
50	DE	1	0	0	0	0
50	DJ	2	0	0	1	0
50	DK	2	0	0	0	0
50	DP	1	0	0	0	0
50	DQ	2	0	0	2	0
50	DT	4	0	0	3	0
50	DU	3	0	0	0	0
50	DX	2	0	0	0	0
50	E2	44	0	0	8	0
50	E3	34	0	0	4	0
50	EA	4	0	0	4	0
50	EB	3	0	0	0	0
50	EC	2	0	0	0	0
50	EE	2	0	0	0	0
50	EJ	4	0	0	1	0
50	EK	5	0	0	1	0
50	EL	10	0	0	1	0
50	EM	2	0	0	0	0
50	EN	7	0	0	6	0
50	EP	6	0	0	1	0
50	EQ	4	0	0	4	0
50	EV	6	0	0	1	0
50	EW	7	0	0	0	0
50	EX	5	0	0	2	0
50	EY	5	0	0	0	0
50	F1	1076	0	0	268	0

*Continued on next page...*



*Continued from previous page...*

Mol	Chain	Non-H	H(model)	H(added)	Clashes	Symm-Clashes
50	FA	7	0	0	2	0
50	FB	4	0	0	1	0
50	FE	1	0	0	0	0
50	FH	1	0	0	0	0
50	FK	2	0	0	0	0
50	FL	3	0	0	1	0
50	FP	2	0	0	0	0
50	FT	4	0	0	4	0
50	FU	4	0	0	0	0
50	G2	34	0	0	2	0
50	G3	26	0	0	9	0
50	GA	6	0	0	6	0
50	GB	3	0	0	0	0
50	GC	2	0	0	0	0
50	GE	2	0	0	0	0
50	GI	1	0	0	0	0
50	GJ	4	0	0	2	0
50	GK	2	0	0	2	0
50	GL	5	0	0	1	0
50	GM	1	0	0	1	0
50	GN	2	0	0	1	0
50	GO	2	0	0	1	0
50	GP	5	0	0	0	0
50	GQ	4	0	0	2	0
50	GV	3	0	0	0	0
50	GW	4	0	0	0	0
50	GX	5	0	0	1	0
50	GY	1	0	0	0	0
50	H1	924	0	0	217	0
50	HA	4	0	0	1	0
50	HB	4	0	0	2	0
50	HJ	2	0	0	0	0
50	HK	2	0	0	0	0
50	HP	1	0	0	0	0
50	HT	5	0	0	5	0
50	HU	2	0	0	0	0
All	All	511395	0	371708	37500	12

The all-atom clashscore is defined as the number of clashes found per 1000 atoms (including hydrogen atoms). The all-atom clashscore for this structure is 43.

The worst 5 of 37500 close contacts within the same asymmetric unit are listed below, sorted by their clash magnitude.

Atom-1	Atom-2	Interatomic distance (Å)	Clash overlap (Å)
28:GG:8:UNK:CG	1:H1:1248:G:N2	1.82	1.41
28:GG:8:UNK:HG3	1:H1:1248:G:N2	1.34	1.40
1:F1:452:U:H5'	14:FO:56:GLN:NE2	1.41	1.35
13:AN:130:LYS:HG2	1:H1:2664:C:OP1	1.22	1.33
46:CY:28:LYS:NZ	1:F1:2252:C:OP1	1.60	1.33

The worst 5 of 12 symmetry-related close contacts are listed below. The label for Atom-2 includes the symmetry operator and encoded unit-cell translations to be applied.

Atom-1	Atom-2	Interatomic distance (Å)	Clash overlap (Å)
34:CM:276:LYS:NZ	1:D1:259:U:O3'[2_546]	1.54	0.66
34:GM:117:THR:OG1	1:H1:192:C:C4'[2_445]	1.57	0.63
34:EM:214:LYS:NZ	1:F1:171:A:O4'[2_456]	1.76	0.44
20:B2:87:C:N4	40:CS:82:GLU:OE2[1_545]	1.84	0.36
1:A1:1840:U:O4	15:DP:74:LYS:N[1_545]	1.88	0.32

## 5.3 Torsion angles [i](#)

### 5.3.1 Protein backbone [i](#)

In the following table, the Percentiles column shows the percent Ramachandran outliers of the chain as a percentile score with respect to all X-ray entries followed by that with respect to entries of similar resolution.

The Analysed column shows the number of residues for which the backbone conformation was analysed, and the total number of residues.

Mol	Chain	Analysed	Favoured	Allowed	Outliers	Percentiles	
2	AA	89/94 (95%)	85 (96%)	4 (4%)	0	100	100
2	DA	89/94 (95%)	85 (96%)	4 (4%)	0	100	100
2	FA	89/94 (95%)	85 (96%)	4 (4%)	0	100	100
2	HA	89/94 (95%)	85 (96%)	4 (4%)	0	100	100
3	AB	49/52 (94%)	46 (94%)	3 (6%)	0	100	100
3	DB	49/52 (94%)	46 (94%)	3 (6%)	0	100	100
3	FB	49/52 (94%)	46 (94%)	3 (6%)	0	100	100
3	HB	49/52 (94%)	46 (94%)	3 (6%)	0	100	100
4	AC	101/109 (93%)	99 (98%)	2 (2%)	0	100	100
4	DC	101/109 (93%)	99 (98%)	2 (2%)	0	100	100

*Continued on next page...*

*Continued from previous page...*

Mol	Chain	Analysed	Favoured	Allowed	Outliers	Percentiles	
4	FC	101/109 (93%)	99 (98%)	2 (2%)	0	100	100
4	HC	101/109 (93%)	99 (98%)	2 (2%)	0	100	100
5	AE	188/191 (98%)	178 (95%)	9 (5%)	1 (0%)	29	67
5	DE	188/191 (98%)	176 (94%)	11 (6%)	1 (0%)	29	67
5	FE	188/191 (98%)	178 (95%)	9 (5%)	1 (0%)	29	67
5	HE	188/191 (98%)	177 (94%)	10 (5%)	1 (0%)	29	67
6	AF	123/126 (98%)	115 (94%)	8 (6%)	0	100	100
6	DF	123/126 (98%)	116 (94%)	7 (6%)	0	100	100
6	FF	123/126 (98%)	115 (94%)	8 (6%)	0	100	100
6	HF	123/126 (98%)	114 (93%)	9 (7%)	0	100	100
7	AG	94/104 (90%)	90 (96%)	4 (4%)	0	100	100
7	DG	94/104 (90%)	90 (96%)	4 (4%)	0	100	100
7	FG	94/104 (90%)	90 (96%)	4 (4%)	0	100	100
7	HG	94/104 (90%)	90 (96%)	4 (4%)	0	100	100
8	AH	105/113 (93%)	100 (95%)	5 (5%)	0	100	100
8	DH	105/113 (93%)	100 (95%)	5 (5%)	0	100	100
8	FH	105/113 (93%)	100 (95%)	4 (4%)	1 (1%)	15	54
8	HH	105/113 (93%)	100 (95%)	5 (5%)	0	100	100
9	AJ	224/248 (90%)	211 (94%)	11 (5%)	2 (1%)	17	57
9	DJ	224/248 (90%)	211 (94%)	11 (5%)	2 (1%)	17	57
9	FJ	224/248 (90%)	212 (95%)	10 (4%)	2 (1%)	17	57
9	HJ	224/248 (90%)	213 (95%)	9 (4%)	2 (1%)	17	57
10	AK	50/129 (39%)	43 (86%)	7 (14%)	0	100	100
10	DK	50/129 (39%)	44 (88%)	6 (12%)	0	100	100
10	FK	50/129 (39%)	44 (88%)	6 (12%)	0	100	100
10	HK	50/129 (39%)	43 (86%)	7 (14%)	0	100	100
11	AL	106/123 (86%)	98 (92%)	8 (8%)	0	100	100
11	DL	106/123 (86%)	98 (92%)	8 (8%)	0	100	100
11	FL	106/123 (86%)	98 (92%)	8 (8%)	0	100	100
11	HL	106/123 (86%)	98 (92%)	8 (8%)	0	100	100
12	AM	98/118 (83%)	92 (94%)	5 (5%)	1 (1%)	15	54

*Continued on next page...*

*Continued from previous page...*

Mol	Chain	Analysed	Favoured	Allowed	Outliers	Percentiles	
12	DM	98/118 (83%)	94 (96%)	3 (3%)	1 (1%)	15	54
12	FM	98/118 (83%)	93 (95%)	4 (4%)	1 (1%)	15	54
12	HM	98/118 (83%)	92 (94%)	5 (5%)	1 (1%)	15	54
13	AN	141/144 (98%)	133 (94%)	7 (5%)	1 (1%)	22	62
13	DN	141/144 (98%)	133 (94%)	7 (5%)	1 (1%)	22	62
13	FN	141/144 (98%)	133 (94%)	8 (6%)	0	100	100
13	HN	141/144 (98%)	133 (94%)	7 (5%)	1 (1%)	22	62
14	AO	132/134 (98%)	125 (95%)	7 (5%)	0	100	100
14	DO	132/134 (98%)	125 (95%)	7 (5%)	0	100	100
14	FO	132/134 (98%)	125 (95%)	7 (5%)	0	100	100
14	HO	132/134 (98%)	125 (95%)	7 (5%)	0	100	100
15	AP	62/89 (70%)	58 (94%)	4 (6%)	0	100	100
15	DP	62/89 (70%)	58 (94%)	4 (6%)	0	100	100
15	FP	62/89 (70%)	58 (94%)	4 (6%)	0	100	100
15	HP	62/89 (70%)	58 (94%)	4 (6%)	0	100	100
16	AQ	100/104 (96%)	89 (89%)	9 (9%)	2 (2%)	7	41
16	DQ	100/104 (96%)	89 (89%)	9 (9%)	2 (2%)	7	41
16	FQ	100/104 (96%)	88 (88%)	10 (10%)	2 (2%)	7	41
16	HQ	100/104 (96%)	89 (89%)	9 (9%)	2 (2%)	7	41
17	AT	63/66 (96%)	59 (94%)	3 (5%)	1 (2%)	9	45
17	DT	63/66 (96%)	60 (95%)	2 (3%)	1 (2%)	9	45
17	FT	63/66 (96%)	60 (95%)	2 (3%)	1 (2%)	9	45
17	HT	63/66 (96%)	60 (95%)	2 (3%)	1 (2%)	9	45
18	AU	201/206 (98%)	188 (94%)	12 (6%)	1 (0%)	29	67
18	DU	201/206 (98%)	187 (93%)	13 (6%)	1 (0%)	29	67
18	FU	201/206 (98%)	187 (93%)	13 (6%)	1 (0%)	29	67
18	HU	201/206 (98%)	189 (94%)	11 (6%)	1 (0%)	29	67
19	AX	186/189 (98%)	177 (95%)	8 (4%)	1 (0%)	29	67
19	DX	186/189 (98%)	178 (96%)	6 (3%)	2 (1%)	14	53
19	FX	186/189 (98%)	178 (96%)	6 (3%)	2 (1%)	14	53
19	HX	186/189 (98%)	177 (95%)	7 (4%)	2 (1%)	14	53

*Continued on next page...*

*Continued from previous page...*

Mol	Chain	Analysed	Favoured	Allowed	Outliers	Percentiles	
22	BA	255/264 (97%)	236 (92%)	19 (8%)	0	100	100
22	CA	255/264 (97%)	235 (92%)	20 (8%)	0	100	100
22	EA	255/264 (97%)	234 (92%)	21 (8%)	0	100	100
22	GA	255/264 (97%)	237 (93%)	18 (7%)	0	100	100
23	BB	384/391 (98%)	371 (97%)	13 (3%)	0	100	100
23	CB	384/391 (98%)	371 (97%)	13 (3%)	0	100	100
23	EB	384/391 (98%)	371 (97%)	13 (3%)	0	100	100
23	GB	384/391 (98%)	370 (96%)	14 (4%)	0	100	100
24	BC	407/410 (99%)	383 (94%)	24 (6%)	0	100	100
24	CC	407/410 (99%)	387 (95%)	20 (5%)	0	100	100
24	EC	407/410 (99%)	384 (94%)	23 (6%)	0	100	100
24	GC	407/410 (99%)	386 (95%)	21 (5%)	0	100	100
25	BD	167/172 (97%)	156 (93%)	11 (7%)	0	100	100
25	CD	167/172 (97%)	156 (93%)	11 (7%)	0	100	100
25	ED	167/172 (97%)	156 (93%)	11 (7%)	0	100	100
25	GD	167/172 (97%)	156 (93%)	11 (7%)	0	100	100
26	BE	184/188 (98%)	171 (93%)	13 (7%)	0	100	100
26	CE	184/188 (98%)	171 (93%)	13 (7%)	0	100	100
26	EE	184/188 (98%)	171 (93%)	13 (7%)	0	100	100
26	GE	184/188 (98%)	171 (93%)	13 (7%)	0	100	100
27	BF	229/255 (90%)	219 (96%)	10 (4%)	0	100	100
27	CF	229/255 (90%)	219 (96%)	10 (4%)	0	100	100
27	EF	229/255 (90%)	219 (96%)	9 (4%)	1 (0%)	34	71
27	GF	229/255 (90%)	219 (96%)	10 (4%)	0	100	100
29	BH	197/215 (92%)	186 (94%)	11 (6%)	0	100	100
29	CH	197/215 (92%)	187 (95%)	10 (5%)	0	100	100
29	EH	197/215 (92%)	186 (94%)	11 (6%)	0	100	100
29	GH	197/215 (92%)	186 (94%)	11 (6%)	0	100	100
30	BI	196/198 (99%)	189 (96%)	7 (4%)	0	100	100
30	CI	196/198 (99%)	189 (96%)	7 (4%)	0	100	100
30	EI	196/198 (99%)	189 (96%)	7 (4%)	0	100	100

*Continued on next page...*

*Continued from previous page...*

Mol	Chain	Analysed	Favoured	Allowed	Outliers	Percentiles	
30	GI	196/198 (99%)	189 (96%)	7 (4%)	0	100	100
31	BJ	136/141 (96%)	132 (97%)	4 (3%)	0	100	100
31	CJ	136/141 (96%)	132 (97%)	4 (3%)	0	100	100
31	EJ	136/141 (96%)	131 (96%)	5 (4%)	0	100	100
31	GJ	136/141 (96%)	132 (97%)	4 (3%)	0	100	100
32	BK	146/149 (98%)	136 (93%)	8 (6%)	2 (1%)	11	47
32	CK	146/149 (98%)	135 (92%)	8 (6%)	3 (2%)	7	39
32	EK	146/149 (98%)	137 (94%)	7 (5%)	2 (1%)	11	47
32	GK	146/149 (98%)	135 (92%)	8 (6%)	3 (2%)	7	39
33	BL	201/204 (98%)	191 (95%)	10 (5%)	0	100	100
33	CL	201/204 (98%)	191 (95%)	10 (5%)	0	100	100
33	EL	201/204 (98%)	191 (95%)	10 (5%)	0	100	100
33	GL	201/204 (98%)	193 (96%)	7 (4%)	1 (0%)	29	67
34	BM	296/301 (98%)	282 (95%)	13 (4%)	1 (0%)	41	75
34	CM	298/301 (99%)	282 (95%)	15 (5%)	1 (0%)	41	75
34	EM	298/301 (99%)	283 (95%)	14 (5%)	1 (0%)	41	75
34	GM	298/301 (99%)	285 (96%)	12 (4%)	1 (0%)	41	75
35	BN	178/181 (98%)	168 (94%)	10 (6%)	0	100	100
35	CN	178/181 (98%)	168 (94%)	10 (6%)	0	100	100
35	EN	178/181 (98%)	168 (94%)	10 (6%)	0	100	100
35	GN	178/181 (98%)	168 (94%)	10 (6%)	0	100	100
36	BO	182/185 (98%)	170 (93%)	11 (6%)	1 (0%)	29	67
36	EO	144/185 (78%)	137 (95%)	7 (5%)	0	100	100
36	GO	151/185 (82%)	143 (95%)	8 (5%)	0	100	100
37	BP	154/157 (98%)	148 (96%)	6 (4%)	0	100	100
37	CP	154/157 (98%)	147 (96%)	7 (4%)	0	100	100
37	EP	154/157 (98%)	148 (96%)	6 (4%)	0	100	100
37	GP	154/157 (98%)	147 (96%)	7 (4%)	0	100	100
38	BQ	155/183 (85%)	146 (94%)	9 (6%)	0	100	100
38	CQ	155/183 (85%)	147 (95%)	8 (5%)	0	100	100
38	EQ	155/183 (85%)	147 (95%)	8 (5%)	0	100	100

*Continued on next page...*

*Continued from previous page...*

Mol	Chain	Analysed	Favoured	Allowed	Outliers	Percentiles	
38	GQ	155/183 (85%)	147 (95%)	8 (5%)	0	100	100
39	BR	119/150 (79%)	115 (97%)	4 (3%)	0	100	100
39	CR	119/150 (79%)	116 (98%)	3 (2%)	0	100	100
39	ER	119/150 (79%)	115 (97%)	4 (3%)	0	100	100
39	GR	119/150 (79%)	114 (96%)	5 (4%)	0	100	100
40	BS	124/135 (92%)	119 (96%)	5 (4%)	0	100	100
40	CS	124/135 (92%)	119 (96%)	5 (4%)	0	100	100
40	ES	124/135 (92%)	119 (96%)	5 (4%)	0	100	100
40	GS	124/135 (92%)	118 (95%)	6 (5%)	0	100	100
41	BT	59/158 (37%)	57 (97%)	2 (3%)	0	100	100
41	CT	59/158 (37%)	56 (95%)	3 (5%)	0	100	100
41	ET	59/158 (37%)	57 (97%)	2 (3%)	0	100	100
41	GT	59/158 (37%)	57 (97%)	2 (3%)	0	100	100
42	BU	121/124 (98%)	112 (93%)	9 (7%)	0	100	100
42	CU	121/124 (98%)	111 (92%)	10 (8%)	0	100	100
42	EU	121/124 (98%)	113 (93%)	8 (7%)	0	100	100
42	GU	121/124 (98%)	112 (93%)	9 (7%)	0	100	100
43	BV	232/239 (97%)	216 (93%)	16 (7%)	0	100	100
43	CV	232/239 (97%)	216 (93%)	16 (7%)	0	100	100
43	EV	232/239 (97%)	216 (93%)	15 (6%)	1 (0%)	34	71
43	GV	232/239 (97%)	216 (93%)	15 (6%)	1 (0%)	34	71
44	BW	108/111 (97%)	102 (94%)	6 (6%)	0	100	100
44	CW	108/111 (97%)	102 (94%)	6 (6%)	0	100	100
44	EW	108/111 (97%)	101 (94%)	7 (6%)	0	100	100
44	GW	108/111 (97%)	102 (94%)	6 (6%)	0	100	100
45	BX	123/134 (92%)	119 (97%)	4 (3%)	0	100	100
45	CX	123/134 (92%)	117 (95%)	6 (5%)	0	100	100
45	EX	123/134 (92%)	118 (96%)	5 (4%)	0	100	100
45	GX	123/134 (92%)	117 (95%)	6 (5%)	0	100	100
46	BY	100/103 (97%)	91 (91%)	9 (9%)	0	100	100
46	CY	100/103 (97%)	90 (90%)	10 (10%)	0	100	100

*Continued on next page...*

Continued from previous page...

Mol	Chain	Analysed	Favoured	Allowed	Outliers	Percentiles	
46	EY	100/103 (97%)	90 (90%)	10 (10%)	0	100	100
46	GY	100/103 (97%)	90 (90%)	10 (10%)	0	100	100
47	CO	145/185 (78%)	138 (95%)	7 (5%)	0	100	100
All	All	26160/28348 (92%)	24720 (94%)	1378 (5%)	62 (0%)	47	80

5 of 62 Ramachandran outliers are listed below:

Mol	Chain	Res	Type
16	AQ	7	VAL
32	BK	24	LYS
32	CK	24	LYS
16	DQ	7	VAL
32	EK	24	LYS

### 5.3.2 Protein sidechains [i](#)

In the following table, the Percentiles column shows the percent sidechain outliers of the chain as a percentile score with respect to all X-ray entries followed by that with respect to entries of similar resolution.

The Analysed column shows the number of residues for which the sidechain conformation was analysed, and the total number of residues.

Mol	Chain	Analysed	Rotameric	Outliers	Percentiles	
2	AA	69/72 (96%)	58 (84%)	11 (16%)	2	15
2	DA	69/72 (96%)	58 (84%)	11 (16%)	2	15
2	FA	69/72 (96%)	59 (86%)	10 (14%)	3	19
2	HA	69/72 (96%)	58 (84%)	11 (16%)	2	15
3	AB	48/49 (98%)	44 (92%)	4 (8%)	11	40
3	DB	48/49 (98%)	44 (92%)	4 (8%)	11	40
3	FB	48/49 (98%)	44 (92%)	4 (8%)	11	40
3	HB	48/49 (98%)	44 (92%)	4 (8%)	11	40
4	AC	95/101 (94%)	92 (97%)	3 (3%)	39	69
4	DC	95/101 (94%)	92 (97%)	3 (3%)	39	69
4	FC	95/101 (94%)	92 (97%)	3 (3%)	39	69
4	HC	95/101 (94%)	92 (97%)	3 (3%)	39	69
5	AE	162/163 (99%)	152 (94%)	10 (6%)	18	52

Continued on next page...



*Continued from previous page...*

Mol	Chain	Analysed	Rotameric	Outliers	Percentiles	
5	DE	162/163 (99%)	152 (94%)	10 (6%)	18	52
5	FE	162/163 (99%)	151 (93%)	11 (7%)	16	48
5	HE	162/163 (99%)	151 (93%)	11 (7%)	16	48
6	AF	111/112 (99%)	107 (96%)	4 (4%)	35	66
6	DF	111/112 (99%)	106 (96%)	5 (4%)	27	62
6	FF	111/112 (99%)	107 (96%)	4 (4%)	35	66
6	HF	111/112 (99%)	107 (96%)	4 (4%)	35	66
7	AG	80/88 (91%)	76 (95%)	4 (5%)	24	58
7	DG	80/88 (91%)	74 (92%)	6 (8%)	13	44
7	FG	80/88 (91%)	75 (94%)	5 (6%)	18	51
7	HG	80/88 (91%)	76 (95%)	4 (5%)	24	58
8	AH	87/92 (95%)	78 (90%)	9 (10%)	7	32
8	DH	87/92 (95%)	78 (90%)	9 (10%)	7	32
8	FH	87/92 (95%)	78 (90%)	9 (10%)	7	32
8	HH	87/92 (95%)	78 (90%)	9 (10%)	7	32
9	AJ	195/216 (90%)	177 (91%)	18 (9%)	9	37
9	DJ	195/216 (90%)	176 (90%)	19 (10%)	8	34
9	FJ	195/216 (90%)	177 (91%)	18 (9%)	9	37
9	HJ	195/216 (90%)	177 (91%)	18 (9%)	9	37
10	AK	46/113 (41%)	43 (94%)	3 (6%)	17	50
10	DK	46/113 (41%)	43 (94%)	3 (6%)	17	50
10	FK	46/113 (41%)	43 (94%)	3 (6%)	17	50
10	HK	46/113 (41%)	43 (94%)	3 (6%)	17	50
11	AL	92/107 (86%)	87 (95%)	5 (5%)	22	56
11	DL	92/107 (86%)	87 (95%)	5 (5%)	22	56
11	FL	92/107 (86%)	88 (96%)	4 (4%)	29	62
11	HL	92/107 (86%)	87 (95%)	5 (5%)	22	56
12	AM	93/110 (84%)	90 (97%)	3 (3%)	39	69
12	DM	93/110 (84%)	90 (97%)	3 (3%)	39	69
12	FM	93/110 (84%)	90 (97%)	3 (3%)	39	69
12	HM	93/110 (84%)	90 (97%)	3 (3%)	39	69

*Continued on next page...*

*Continued from previous page...*

Mol	Chain	Analysed	Rotameric	Outliers	Percentiles	
13	AN	130/131 (99%)	123 (95%)	7 (5%)	22	56
13	DN	130/131 (99%)	122 (94%)	8 (6%)	18	52
13	FN	130/131 (99%)	123 (95%)	7 (5%)	22	56
13	HN	130/131 (99%)	123 (95%)	7 (5%)	22	56
14	AO	108/108 (100%)	102 (94%)	6 (6%)	21	55
14	DO	108/108 (100%)	102 (94%)	6 (6%)	21	55
14	FO	108/108 (100%)	100 (93%)	8 (7%)	13	45
14	HO	108/108 (100%)	102 (94%)	6 (6%)	21	55
15	AP	60/77 (78%)	56 (93%)	4 (7%)	16	49
15	DP	60/77 (78%)	56 (93%)	4 (7%)	16	49
15	FP	60/77 (78%)	56 (93%)	4 (7%)	16	49
15	HP	60/77 (78%)	56 (93%)	4 (7%)	16	49
16	AQ	81/83 (98%)	75 (93%)	6 (7%)	13	45
16	DQ	81/83 (98%)	75 (93%)	6 (7%)	13	45
16	FQ	81/83 (98%)	75 (93%)	6 (7%)	13	45
16	HQ	81/83 (98%)	75 (93%)	6 (7%)	13	45
17	AT	61/62 (98%)	55 (90%)	6 (10%)	8	34
17	DT	61/62 (98%)	57 (93%)	4 (7%)	16	50
17	FT	61/62 (98%)	57 (93%)	4 (7%)	16	50
17	HT	61/62 (98%)	57 (93%)	4 (7%)	16	50
18	AU	169/171 (99%)	159 (94%)	10 (6%)	19	53
18	DU	169/171 (99%)	161 (95%)	8 (5%)	26	60
18	FU	169/171 (99%)	160 (95%)	9 (5%)	22	56
18	HU	169/171 (99%)	161 (95%)	8 (5%)	26	60
19	AX	167/168 (99%)	153 (92%)	14 (8%)	11	40
19	DX	167/168 (99%)	152 (91%)	15 (9%)	9	38
19	FX	167/168 (99%)	151 (90%)	16 (10%)	8	35
19	HX	167/168 (99%)	154 (92%)	13 (8%)	12	43
22	BA	196/198 (99%)	165 (84%)	31 (16%)	2	16
22	CA	196/198 (99%)	164 (84%)	32 (16%)	2	14
22	EA	196/198 (99%)	164 (84%)	32 (16%)	2	14

*Continued on next page...*

*Continued from previous page...*

Mol	Chain	Analysed	Rotameric	Outliers	Percentiles	
22	GA	196/198 (99%)	165 (84%)	31 (16%)	2	16
23	BB	330/334 (99%)	306 (93%)	24 (7%)	14	45
23	CB	330/334 (99%)	307 (93%)	23 (7%)	15	47
23	EB	330/334 (99%)	308 (93%)	22 (7%)	16	49
23	GB	330/334 (99%)	306 (93%)	24 (7%)	14	45
24	BC	325/326 (100%)	302 (93%)	23 (7%)	14	47
24	CC	325/326 (100%)	302 (93%)	23 (7%)	14	47
24	EC	325/326 (100%)	300 (92%)	25 (8%)	13	43
24	GC	325/326 (100%)	300 (92%)	25 (8%)	13	43
25	BD	146/149 (98%)	136 (93%)	10 (7%)	16	48
25	CD	146/149 (98%)	136 (93%)	10 (7%)	16	48
25	ED	146/149 (98%)	135 (92%)	11 (8%)	13	44
25	GD	146/149 (98%)	136 (93%)	10 (7%)	16	48
26	BE	163/165 (99%)	157 (96%)	6 (4%)	34	65
26	CE	163/165 (99%)	157 (96%)	6 (4%)	34	65
26	EE	163/165 (99%)	157 (96%)	6 (4%)	34	65
26	GE	163/165 (99%)	157 (96%)	6 (4%)	34	65
27	BF	201/222 (90%)	194 (96%)	7 (4%)	36	67
27	CF	201/222 (90%)	194 (96%)	7 (4%)	36	67
27	EF	201/222 (90%)	194 (96%)	7 (4%)	36	67
27	GF	201/222 (90%)	194 (96%)	7 (4%)	36	67
29	BH	169/180 (94%)	155 (92%)	14 (8%)	11	40
29	CH	169/180 (94%)	155 (92%)	14 (8%)	11	40
29	EH	169/180 (94%)	156 (92%)	13 (8%)	13	43
29	GH	169/180 (94%)	153 (90%)	16 (10%)	8	35
30	BI	166/166 (100%)	150 (90%)	16 (10%)	8	35
30	CI	166/166 (100%)	149 (90%)	17 (10%)	7	32
30	EI	166/166 (100%)	150 (90%)	16 (10%)	8	35
30	GI	166/166 (100%)	150 (90%)	16 (10%)	8	35
31	BJ	107/108 (99%)	98 (92%)	9 (8%)	11	40
31	CJ	107/108 (99%)	99 (92%)	8 (8%)	13	44

*Continued on next page...*

*Continued from previous page...*

Mol	Chain	Analysed	Rotameric	Outliers	Percentiles	
31	EJ	107/108 (99%)	99 (92%)	8 (8%)	13	44
31	GJ	107/108 (99%)	99 (92%)	8 (8%)	13	44
32	BK	120/121 (99%)	110 (92%)	10 (8%)	11	40
32	CK	120/121 (99%)	111 (92%)	9 (8%)	13	44
32	EK	120/121 (99%)	110 (92%)	10 (8%)	11	40
32	GK	120/121 (99%)	110 (92%)	10 (8%)	11	40
33	BL	174/175 (99%)	165 (95%)	9 (5%)	23	57
33	CL	174/175 (99%)	165 (95%)	9 (5%)	23	57
33	EL	174/175 (99%)	165 (95%)	9 (5%)	23	57
33	GL	174/175 (99%)	166 (95%)	8 (5%)	27	61
34	BM	252/254 (99%)	239 (95%)	13 (5%)	23	57
34	CM	253/254 (100%)	242 (96%)	11 (4%)	29	62
34	EM	253/254 (100%)	242 (96%)	11 (4%)	29	62
34	GM	253/254 (100%)	240 (95%)	13 (5%)	24	58
35	BN	159/160 (99%)	145 (91%)	14 (9%)	10	39
35	CN	159/160 (99%)	146 (92%)	13 (8%)	11	41
35	EN	159/160 (99%)	145 (91%)	14 (9%)	10	39
35	GN	159/160 (99%)	146 (92%)	13 (8%)	11	41
36	BO	158/159 (99%)	148 (94%)	10 (6%)	18	51
36	EO	126/159 (79%)	116 (92%)	10 (8%)	12	42
36	GO	127/159 (80%)	117 (92%)	10 (8%)	12	42
37	BP	134/135 (99%)	124 (92%)	10 (8%)	13	44
37	CP	134/135 (99%)	126 (94%)	8 (6%)	19	53
37	EP	134/135 (99%)	125 (93%)	9 (7%)	16	49
37	GP	134/135 (99%)	125 (93%)	9 (7%)	16	49
38	BQ	128/148 (86%)	115 (90%)	13 (10%)	7	32
38	CQ	128/148 (86%)	115 (90%)	13 (10%)	7	32
38	EQ	128/148 (86%)	115 (90%)	13 (10%)	7	32
38	GQ	128/148 (86%)	115 (90%)	13 (10%)	7	32
39	BR	108/132 (82%)	101 (94%)	7 (6%)	17	50
39	CR	108/132 (82%)	101 (94%)	7 (6%)	17	50

*Continued on next page...*

*Continued from previous page...*

Mol	Chain	Analysed	Rotameric	Outliers	Percentiles	
39	ER	108/132 (82%)	102 (94%)	6 (6%)	21	55
39	GR	108/132 (82%)	103 (95%)	5 (5%)	27	61
40	BS	113/120 (94%)	105 (93%)	8 (7%)	14	47
40	CS	113/120 (94%)	104 (92%)	9 (8%)	12	42
40	ES	113/120 (94%)	105 (93%)	8 (7%)	14	47
40	GS	113/120 (94%)	104 (92%)	9 (8%)	12	42
41	BT	52/130 (40%)	46 (88%)	6 (12%)	5	27
41	CT	52/130 (40%)	46 (88%)	6 (12%)	5	27
41	ET	52/130 (40%)	46 (88%)	6 (12%)	5	27
41	GT	52/130 (40%)	46 (88%)	6 (12%)	5	27
42	BU	105/106 (99%)	96 (91%)	9 (9%)	10	39
42	CU	105/106 (99%)	96 (91%)	9 (9%)	10	39
42	EU	105/106 (99%)	96 (91%)	9 (9%)	10	39
42	GU	105/106 (99%)	96 (91%)	9 (9%)	10	39
43	BV	197/202 (98%)	186 (94%)	11 (6%)	21	55
43	CV	197/202 (98%)	187 (95%)	10 (5%)	24	58
43	EV	197/202 (98%)	188 (95%)	9 (5%)	27	61
43	GV	197/202 (98%)	187 (95%)	10 (5%)	24	58
44	BW	100/101 (99%)	96 (96%)	4 (4%)	31	64
44	CW	100/101 (99%)	95 (95%)	5 (5%)	24	58
44	EW	100/101 (99%)	95 (95%)	5 (5%)	24	58
44	GW	100/101 (99%)	96 (96%)	4 (4%)	31	64
45	BX	104/111 (94%)	88 (85%)	16 (15%)	2	17
45	CX	104/111 (94%)	87 (84%)	17 (16%)	2	14
45	EX	104/111 (94%)	88 (85%)	16 (15%)	2	17
45	GX	104/111 (94%)	88 (85%)	16 (15%)	2	17
46	BY	79/80 (99%)	72 (91%)	7 (9%)	9	38
46	CY	79/80 (99%)	71 (90%)	8 (10%)	7	33
46	EY	79/80 (99%)	71 (90%)	8 (10%)	7	33
46	GY	79/80 (99%)	73 (92%)	6 (8%)	13	44
47	CO	126/127 (99%)	116 (92%)	10 (8%)	12	42

*Continued on next page...*

Continued from previous page...

Mol	Chain	Analysed	Rotameric	Outliers	Percentiles
All	All	22468/23988 (94%)	20823 (93%)	1645 (7%)	14 45

5 of 1645 residues with a non-rotameric sidechain are listed below:

Mol	Chain	Res	Type
27	EF	103	ARG
7	FG	86	ARG
13	HN	36	ARG
30	EI	135	CYS
27	EF	74	THR

Sometimes sidechains can be flipped to improve hydrogen bonding and reduce clashes. 5 of 750 such sidechains are listed below:

Mol	Chain	Res	Type
38	EQ	139	ASN
23	GB	210	ASN
43	EV	219	HIS
38	EQ	135	HIS
11	FL	58	GLN

### 5.3.3 RNA [i](#)

Mol	Chain	Analysed	Backbone Outliers	Pucker Outliers
1	A1	3114/3354 (92%)	1118 (35%)	209 (6%)
1	D1	3114/3354 (92%)	1113 (35%)	215 (6%)
1	F1	3114/3354 (92%)	1113 (35%)	211 (6%)
1	H1	3114/3354 (92%)	1113 (35%)	210 (6%)
20	B2	154/154 (100%)	58 (37%)	13 (8%)
20	C2	154/154 (100%)	60 (38%)	13 (8%)
20	E2	154/154 (100%)	60 (38%)	13 (8%)
20	G2	154/154 (100%)	60 (38%)	13 (8%)
21	B3	119/120 (99%)	38 (31%)	1 (0%)
21	C3	119/120 (99%)	39 (32%)	1 (0%)
21	E3	119/120 (99%)	38 (31%)	1 (0%)
21	G3	119/120 (99%)	38 (31%)	1 (0%)
All	All	13548/14512 (93%)	4848 (35%)	901 (6%)

5 of 4848 RNA backbone outliers are listed below:

Mol	Chain	Res	Type
1	A1	9	G
1	A1	16	G
1	A1	17	C
1	A1	19	A
1	A1	20	G

5 of 901 RNA pucker outliers are listed below:

Mol	Chain	Res	Type
20	E2	112	G
1	H1	3205	A
1	F1	1617	G
1	H1	3162	A
1	H1	1617	G

#### 5.4 Non-standard residues in protein, DNA, RNA chains [i](#)

There are no non-standard protein/DNA/RNA residues in this entry.

#### 5.5 Carbohydrates [i](#)

There are no monosaccharides in this entry.

#### 5.6 Ligand geometry [i](#)

Of 885 ligands modelled in this entry, 885 are monoatomic - leaving 0 for Mogul analysis.

There are no bond length outliers.

There are no bond angle outliers.

There are no chirality outliers.

There are no torsion outliers.

There are no ring outliers.

No monomer is involved in short contacts.

#### 5.7 Other polymers [i](#)

There are no such residues in this entry.

## 5.8 Polymer linkage issues

The following chains have linkage breaks:

Mol	Chain	Number of breaks
1	F1	1

All chain breaks are listed below:

Model	Chain	Residue-1	Atom-1	Residue-2	Atom-2	Distance (Å)
1	F1	2239:A	O3'	2240:C	P	1.91



## 6 Fit of model and data i

### 6.1 Protein, DNA and RNA chains i

In the following table, the column labelled ‘#RSRZ> 2’ contains the number (and percentage) of RSRZ outliers, followed by percent RSRZ outliers for the chain as percentile scores relative to all X-ray entries and entries of similar resolution. The OWAB column contains the minimum, median, 95<sup>th</sup> percentile and maximum values of the occupancy-weighted average B-factor per residue. The column labelled ‘Q< 0.9’ lists the number of (and percentage) of residues with an average occupancy less than 0.9.

Mol	Chain	Analysed	<RSRZ>	#RSRZ>2	OWAB(Å <sup>2</sup> )	Q<0.9
1	A1	3119/3354 (92%)	0.13	90 (2%) 51 38	42, 91, 187, 390	0
1	D1	3119/3354 (92%)	0.05	34 (1%) 80 69	40, 79, 164, 330	0
1	F1	3119/3354 (92%)	0.18	62 (1%) 65 52	51, 94, 176, 357	0
1	H1	3119/3354 (92%)	0.49	136 (4%) 34 25	54, 121, 213, 367	0
2	AA	91/94 (96%)	-0.16	2 (2%) 62 48	29, 65, 120, 243	0
2	DA	91/94 (96%)	-0.09	0 100 100	34, 66, 123, 226	0
2	FA	91/94 (96%)	0.21	2 (2%) 62 48	47, 83, 132, 204	0
2	HA	91/94 (96%)	0.86	12 (13%) 3 3	74, 119, 186, 243	0
3	AB	51/52 (98%)	-0.20	1 (1%) 65 52	44, 63, 110, 148	0
3	DB	51/52 (98%)	-0.13	1 (1%) 65 52	49, 69, 111, 146	0
3	FB	51/52 (98%)	0.09	0 100 100	59, 86, 118, 167	0
3	HB	51/52 (98%)	0.79	8 (15%) 2 2	90, 114, 144, 197	0
4	AC	103/109 (94%)	0.37	3 (2%) 51 38	73, 117, 154, 228	0
4	DC	103/109 (94%)	-0.01	0 100 100	46, 84, 135, 194	0
4	FC	103/109 (94%)	0.01	1 (0%) 82 71	58, 96, 156, 192	0
4	HC	103/109 (94%)	0.32	3 (2%) 51 38	81, 130, 176, 199	0
5	AE	190/191 (99%)	0.19	12 (6%) 20 15	69, 122, 171, 214	0
5	DE	190/191 (99%)	0.08	1 (0%) 91 84	74, 124, 169, 226	0
5	FE	190/191 (99%)	0.20	8 (4%) 36 27	60, 123, 176, 227	0
5	HE	190/191 (99%)	0.35	14 (7%) 14 12	76, 141, 194, 227	0
6	AF	125/126 (99%)	0.02	5 (4%) 38 28	71, 111, 156, 213	0
6	DF	125/126 (99%)	-0.22	2 (1%) 72 59	70, 106, 157, 190	0
6	FF	125/126 (99%)	0.01	6 (4%) 30 23	63, 109, 166, 245	0
6	HF	125/126 (99%)	0.02	0 100 100	74, 113, 163, 224	0

*Continued on next page...*

Continued from previous page...

Mol	Chain	Analysed	<RSRZ>	#RSRZ>2	OWAB(Å <sup>2</sup> )	Q<0.9
7	AG	96/104 (92%)	0.08	1 (1%) 82 71	62, 103, 188, 218	0
7	DG	96/104 (92%)	0.06	4 (4%) 36 27	57, 114, 179, 222	0
7	FG	96/104 (92%)	0.18	2 (2%) 63 50	81, 112, 176, 199	0
7	HG	96/104 (92%)	0.21	1 (1%) 82 71	94, 134, 183, 218	0
8	AH	107/113 (94%)	-0.11	0 100 100	61, 91, 127, 159	0
8	DH	107/113 (94%)	-0.12	0 100 100	54, 89, 127, 138	0
8	FH	107/113 (94%)	-0.04	0 100 100	57, 89, 122, 164	0
8	HH	107/113 (94%)	0.14	0 100 100	68, 109, 141, 181	0
9	AJ	226/248 (91%)	-0.40	0 100 100	52, 90, 138, 190	0
9	DJ	226/248 (91%)	-0.36	0 100 100	51, 89, 136, 206	0
9	FJ	226/248 (91%)	-0.41	1 (0%) 92 87	38, 82, 130, 183	0
9	HJ	226/248 (91%)	-0.49	0 100 100	40, 78, 123, 155	0
10	AK	52/129 (40%)	0.12	2 (3%) 40 30	73, 101, 146, 182	0
10	DK	52/129 (40%)	-0.32	1 (1%) 66 53	53, 79, 134, 151	0
10	FK	52/129 (40%)	-0.40	0 100 100	56, 81, 139, 189	0
10	HK	52/129 (40%)	-0.27	0 100 100	61, 77, 118, 158	0
11	AL	108/123 (87%)	-0.12	1 (0%) 84 73	38, 73, 130, 165	0
11	DL	108/123 (87%)	-0.10	1 (0%) 84 73	47, 85, 144, 217	0
11	FL	108/123 (87%)	0.13	1 (0%) 84 73	66, 98, 135, 174	0
11	HL	108/123 (87%)	0.51	5 (4%) 32 24	90, 117, 156, 183	0
12	AM	100/118 (84%)	0.20	3 (3%) 50 37	72, 121, 155, 185	0
12	DM	100/118 (84%)	0.16	4 (4%) 38 28	73, 126, 179, 199	0
12	FM	100/118 (84%)	0.29	2 (2%) 65 52	93, 144, 196, 208	0
12	HM	100/118 (84%)	0.06	2 (2%) 65 52	98, 151, 195, 214	0
13	AN	143/144 (99%)	-0.20	1 (0%) 87 79	59, 97, 163, 189	0
13	DN	143/144 (99%)	-0.06	1 (0%) 87 79	73, 121, 179, 214	0
13	FN	143/144 (99%)	-0.02	1 (0%) 87 79	72, 122, 175, 208	0
13	HN	143/144 (99%)	0.30	3 (2%) 63 50	92, 148, 189, 217	0
14	AO	134/134 (100%)	-0.20	1 (0%) 87 79	66, 116, 162, 202	0
14	DO	134/134 (100%)	-0.11	1 (0%) 87 79	52, 99, 151, 209	0
14	FO	134/134 (100%)	0.04	2 (1%) 73 61	65, 118, 167, 219	0

Continued on next page...

Continued from previous page...

Mol	Chain	Analysed	<RSRZ>	#RSRZ>2	OWAB(Å <sup>2</sup> )	Q<0.9
14	HO	134/134 (100%)	0.48	11 (8%) 11 10	96, 143, 197, 227	0
15	AP	66/89 (74%)	0.39	3 (4%) 33 24	55, 128, 209, 241	0
15	DP	66/89 (74%)	0.32	5 (7%) 13 11	73, 116, 176, 245	0
15	FP	66/89 (74%)	0.56	4 (6%) 21 16	99, 143, 202, 214	0
15	HP	66/89 (74%)	1.03	8 (12%) 4 4	99, 149, 219, 247	0
16	AQ	102/104 (98%)	0.09	3 (2%) 51 38	72, 122, 172, 208	0
16	DQ	102/104 (98%)	-0.01	3 (2%) 51 38	63, 105, 151, 186	0
16	FQ	102/104 (98%)	0.01	2 (1%) 65 52	72, 114, 166, 190	0
16	HQ	102/104 (98%)	0.57	6 (5%) 22 16	110, 154, 195, 203	0
17	AT	65/66 (98%)	0.37	4 (6%) 20 15	76, 121, 156, 193	0
17	DT	65/66 (98%)	0.11	1 (1%) 73 61	51, 87, 122, 211	0
17	FT	65/66 (98%)	0.26	1 (1%) 73 61	51, 107, 144, 201	0
17	HT	65/66 (98%)	0.76	4 (6%) 20 15	69, 136, 171, 222	0
18	AU	203/206 (98%)	0.09	4 (1%) 65 52	74, 122, 179, 233	0
18	DU	203/206 (98%)	-0.13	0 100 100	48, 98, 158, 198	0
18	FU	203/206 (98%)	-0.07	1 (0%) 91 84	67, 116, 174, 203	0
18	HU	203/206 (98%)	0.54	19 (9%) 8 6	102, 155, 206, 240	0
19	AX	188/189 (99%)	-0.20	1 (0%) 91 84	72, 105, 145, 201	0
19	DX	188/189 (99%)	-0.29	0 100 100	54, 89, 128, 170	0
19	FX	188/189 (99%)	-0.09	1 (0%) 91 84	62, 98, 141, 179	0
19	HX	188/189 (99%)	-0.03	0 100 100	74, 106, 135, 193	0
20	B2	154/154 (100%)	-0.11	2 (1%) 77 65	61, 80, 118, 192	0
20	C2	154/154 (100%)	-0.03	0 100 100	54, 80, 120, 186	0
20	E2	154/154 (100%)	0.16	3 (1%) 66 53	74, 105, 142, 189	0
20	G2	154/154 (100%)	0.73	13 (8%) 11 9	98, 146, 182, 210	0
21	B3	120/120 (100%)	0.46	4 (3%) 46 35	90, 150, 184, 217	0
21	C3	120/120 (100%)	-0.10	0 100 100	64, 98, 116, 161	0
21	E3	120/120 (100%)	0.03	0 100 100	72, 120, 147, 172	0
21	G3	120/120 (100%)	0.45	4 (3%) 46 35	95, 138, 175, 235	0
22	BA	257/264 (97%)	-0.02	9 (3%) 44 33	30, 70, 134, 233	0
22	CA	257/264 (97%)	-0.18	10 (3%) 39 29	31, 75, 139, 238	0

Continued on next page...

Continued from previous page...

Mol	Chain	Analysed	<RSRZ>	#RSRZ>2	OWAB(Å <sup>2</sup> )	Q<0.9
22	EA	257/264 (97%)	-0.16	10 (3%) 39 29	40, 79, 136, 217	0
22	GA	257/264 (97%)	0.22	13 (5%) 28 20	60, 106, 157, 242	0
23	BB	386/391 (98%)	-0.32	5 (1%) 77 65	33, 69, 120, 227	0
23	CB	386/391 (98%)	-0.44	2 (0%) 91 84	34, 75, 123, 222	0
23	EB	386/391 (98%)	-0.36	4 (1%) 82 71	38, 75, 123, 230	0
23	GB	386/391 (98%)	-0.35	4 (1%) 82 71	51, 82, 132, 217	0
24	BC	409/410 (99%)	-0.01	12 (2%) 51 38	37, 107, 173, 241	0
24	CC	409/410 (99%)	-0.20	2 (0%) 91 84	40, 91, 151, 206	0
24	EC	409/410 (99%)	-0.07	5 (1%) 79 67	54, 107, 162, 237	0
24	GC	409/410 (99%)	0.34	17 (4%) 36 27	77, 143, 195, 252	0
25	BD	169/172 (98%)	0.96	23 (13%) 3 3	116, 159, 200, 225	0
25	CD	169/172 (98%)	0.12	4 (2%) 59 45	70, 110, 151, 188	0
25	ED	169/172 (98%)	0.49	8 (4%) 31 23	89, 133, 179, 209	0
25	GD	169/172 (98%)	0.66	19 (11%) 5 5	96, 139, 182, 216	0
26	BE	186/188 (98%)	-0.08	0 100 100	65, 109, 150, 194	0
26	CE	186/188 (98%)	-0.19	0 100 100	59, 94, 131, 171	0
26	EE	186/188 (98%)	-0.08	1 (0%) 91 84	60, 94, 139, 195	0
26	GE	186/188 (98%)	-0.12	0 100 100	53, 91, 135, 220	0
27	BF	231/255 (90%)	0.18	7 (3%) 50 37	70, 122, 176, 252	0
27	CF	231/255 (90%)	-0.14	3 (1%) 77 65	71, 115, 175, 233	0
27	EF	231/255 (90%)	0.00	6 (2%) 56 42	76, 120, 187, 241	0
27	GF	231/255 (90%)	0.60	17 (7%) 14 12	112, 166, 210, 233	0
28	BG	0/123	-	-	-	-
28	CG	0/123	-	-	-	-
28	EG	0/123	-	-	-	-
28	GG	0/123	-	-	-	-
29	BH	201/215 (93%)	0.18	6 (2%) 50 37	79, 133, 181, 221	0
29	CH	201/215 (93%)	-0.24	1 (0%) 91 84	42, 93, 139, 153	0
29	EH	201/215 (93%)	-0.15	2 (0%) 82 71	50, 105, 158, 202	0
29	GH	201/215 (93%)	0.08	2 (0%) 82 71	71, 118, 171, 203	0
30	BI	198/198 (100%)	-0.21	2 (1%) 82 71	51, 85, 152, 185	0
30	CI	198/198 (100%)	-0.36	0 100 100	48, 78, 149, 208	0

Continued on next page...

Continued from previous page...

Mol	Chain	Analysed	<RSRZ>	#RSRZ>2	OWAB(Å <sup>2</sup> )	Q<0.9
30	EI	198/198 (100%)	-0.26	2 (1%) 82 71	47, 79, 152, 174	0
30	GI	198/198 (100%)	-0.20	2 (1%) 82 71	53, 91, 151, 195	0
31	BJ	138/141 (97%)	-0.43	0 100 100	42, 68, 112, 160	0
31	CJ	138/141 (97%)	-0.47	0 100 100	40, 65, 108, 150	0
31	EJ	138/141 (97%)	-0.44	3 (2%) 62 48	40, 65, 108, 202	0
31	GJ	138/141 (97%)	-0.41	1 (0%) 87 79	30, 60, 98, 186	0
32	BK	148/149 (99%)	0.01	4 (2%) 54 41	50, 105, 158, 221	0
32	CK	148/149 (99%)	-0.27	0 100 100	36, 74, 124, 184	0
32	EK	148/149 (99%)	-0.10	0 100 100	50, 95, 140, 228	0
32	GK	148/149 (99%)	0.53	11 (7%) 14 12	78, 129, 181, 208	0
33	BL	203/204 (99%)	-0.26	1 (0%) 91 84	57, 83, 120, 153	0
33	CL	203/204 (99%)	-0.36	0 100 100	37, 74, 106, 180	0
33	EL	203/204 (99%)	-0.10	0 100 100	51, 89, 121, 160	0
33	GL	203/204 (99%)	0.39	7 (3%) 45 34	89, 133, 165, 205	0
34	BM	298/301 (99%)	0.35	10 (3%) 45 34	87, 152, 201, 240	0
34	CM	300/301 (99%)	-0.12	3 (1%) 82 71	61, 110, 166, 208	0
34	EM	300/301 (99%)	0.23	17 (5%) 23 17	76, 127, 183, 233	0
34	GM	300/301 (99%)	0.69	28 (9%) 8 7	98, 157, 204, 233	0
35	BN	180/181 (99%)	0.04	1 (0%) 89 81	68, 110, 150, 224	0
35	CN	180/181 (99%)	-0.33	0 100 100	47, 82, 125, 185	0
35	EN	180/181 (99%)	-0.10	1 (0%) 89 81	63, 101, 142, 187	0
35	GN	180/181 (99%)	0.28	4 (2%) 62 48	94, 139, 188, 248	0
36	BO	184/185 (99%)	0.27	14 (7%) 13 11	29, 78, 184, 207	0
36	EO	146/185 (78%)	0.19	3 (2%) 63 50	57, 95, 128, 194	0
36	GO	153/185 (82%)	0.39	8 (5%) 27 20	67, 109, 153, 262	0
37	BP	156/157 (99%)	0.16	0 100 100	70, 116, 169, 203	0
37	CP	156/157 (99%)	-0.27	0 100 100	42, 79, 136, 152	0
37	EP	156/157 (99%)	-0.09	2 (1%) 77 65	56, 100, 148, 183	0
37	GP	156/157 (99%)	0.46	6 (3%) 40 30	69, 122, 163, 222	0
38	BQ	157/183 (85%)	-0.34	0 100 100	31, 68, 121, 173	0
38	CQ	157/183 (85%)	-0.32	1 (0%) 89 81	26, 70, 124, 158	0

Continued on next page...

Continued from previous page...

Mol	Chain	Analysed	<RSRZ>	#RSRZ>2	OWAB(Å <sup>2</sup> )	Q<0.9
38	EQ	157/183 (85%)	-0.18	1 (0%) 89 81	48, 86, 141, 177	0
38	GQ	157/183 (85%)	0.16	2 (1%) 77 65	60, 106, 157, 200	0
39	BR	121/150 (80%)	-0.20	1 (0%) 86 75	42, 78, 129, 185	0
39	CR	121/150 (80%)	0.05	1 (0%) 86 75	54, 88, 129, 172	0
39	ER	121/150 (80%)	0.18	5 (4%) 37 27	65, 112, 146, 172	0
39	GR	121/150 (80%)	0.45	9 (7%) 14 12	97, 138, 175, 191	0
40	BS	126/135 (93%)	-0.17	0 100 100	62, 98, 133, 177	0
40	CS	126/135 (93%)	0.02	4 (3%) 47 36	46, 89, 127, 152	0
40	ES	126/135 (93%)	0.16	5 (3%) 38 28	74, 112, 151, 184	0
40	GS	126/135 (93%)	0.58	9 (7%) 16 13	101, 143, 186, 218	0
41	BT	61/158 (38%)	-0.38	0 100 100	39, 73, 127, 158	0
41	CT	61/158 (38%)	-0.31	0 100 100	37, 73, 105, 137	0
41	ET	61/158 (38%)	-0.35	0 100 100	45, 78, 113, 147	0
41	GT	61/158 (38%)	-0.20	0 100 100	42, 76, 115, 138	0
42	BU	123/124 (99%)	-0.12	1 (0%) 86 75	59, 101, 139, 204	0
42	CU	123/124 (99%)	-0.22	1 (0%) 86 75	49, 92, 143, 163	0
42	EU	123/124 (99%)	-0.06	2 (1%) 72 59	79, 114, 157, 220	0
42	GU	123/124 (99%)	0.80	19 (15%) 2 2	113, 156, 193, 233	0
43	BV	234/239 (97%)	-0.32	0 100 100	61, 107, 160, 213	0
43	CV	234/239 (97%)	-0.44	0 100 100	47, 87, 145, 213	0
43	EV	234/239 (97%)	-0.36	1 (0%) 92 87	53, 102, 159, 232	0
43	GV	234/239 (97%)	-0.15	1 (0%) 92 87	75, 121, 173, 239	0
44	BW	110/111 (99%)	-0.21	2 (1%) 68 55	36, 64, 155, 204	0
44	CW	110/111 (99%)	-0.19	0 100 100	43, 76, 138, 178	0
44	EW	110/111 (99%)	-0.00	1 (0%) 84 73	56, 88, 170, 227	0
44	GW	110/111 (99%)	0.09	1 (0%) 84 73	63, 102, 183, 216	0
45	BX	125/134 (93%)	-0.01	2 (1%) 72 59	53, 89, 128, 202	0
45	CX	125/134 (93%)	-0.27	1 (0%) 86 75	40, 78, 116, 196	0
45	EX	125/134 (93%)	-0.13	2 (1%) 72 59	49, 88, 129, 233	0
45	GX	125/134 (93%)	0.34	4 (3%) 47 36	73, 117, 162, 215	0
46	BY	102/103 (99%)	-0.11	4 (3%) 39 29	40, 74, 164, 222	0

Continued on next page...

Continued from previous page...

Mol	Chain	Analysed	<RSRZ>	#RSRZ>2	OWAB(Å <sup>2</sup> )	Q<0.9
46	CY	102/103 (99%)	-0.21	4 (3%) 39 29	41, 83, 173, 196	0
46	EY	102/103 (99%)	-0.08	3 (2%) 51 38	45, 84, 156, 193	0
46	GY	102/103 (99%)	0.05	4 (3%) 39 29	53, 102, 189, 222	0
47	CO	146/185 (78%)	-0.08	0 100 100	45, 79, 115, 148	0
All	All	40083/43352 (92%)	0.07	964 (2%) 59 45	26, 101, 177, 390	0

The worst 5 of 964 RSRZ outliers are listed below:

Mol	Chain	Res	Type	RSRZ
2	HA	92	ALA	14.8
1	A1	2500	C	11.2
1	H1	1597	U	11.2
1	A1	1597	U	10.4
23	BB	387	GLU	10.1

## 6.2 Non-standard residues in protein, DNA, RNA chains [i](#)

There are no non-standard protein/DNA/RNA residues in this entry.

## 6.3 Carbohydrates [i](#)

There are no monosaccharides in this entry.

## 6.4 Ligands [i](#)

In the following table, the Atoms column lists the number of modelled atoms in the group and the number defined in the chemical component dictionary. The B-factors column lists the minimum, median, 95<sup>th</sup> percentile and maximum values of B factors of atoms in the group. The column labelled 'Q< 0.9' lists the number of atoms with occupancy less than 0.9.

Mol	Type	Chain	Res	Atoms	RSCC	RSR	B-factors(Å <sup>2</sup> )	Q<0.9
48	MG	D1	3463	1/1	-0.16	1.03	176,176,176,176	0
48	MG	G2	204	1/1	-0.14	0.92	181,181,181,181	0
48	MG	EW	201	1/1	-0.02	0.33	172,172,172,172	0
48	MG	H1	3529	1/1	0.04	0.33	214,214,214,214	0
48	MG	F1	3411	1/1	0.09	0.65	142,142,142,142	0
48	MG	H1	3489	1/1	0.10	0.45	206,206,206,206	0
48	MG	H1	3551	1/1	0.12	3.30	202,202,202,202	0

Continued on next page...



*Continued from previous page...*

Mol	Type	Chain	Res	Atoms	RSCC	RSR	B-factors( $\text{\AA}^2$ )	Q<0.9
48	MG	H1	3534	1/1	0.16	1.54	221,221,221,221	0
48	MG	G3	202	1/1	0.20	0.62	136,136,136,136	0
48	MG	H1	3519	1/1	0.21	0.31	151,151,151,151	0
48	MG	A1	3527	1/1	0.28	0.30	119,119,119,119	0
48	MG	F1	3561	1/1	0.30	0.24	167,167,167,167	0
48	MG	A1	3568	1/1	0.34	0.36	173,173,173,173	0
48	MG	F1	3415	1/1	0.35	0.32	118,118,118,118	0
48	MG	E3	204	1/1	0.36	1.60	199,199,199,199	0
48	MG	D1	3528	1/1	0.39	0.26	123,123,123,123	0
48	MG	H1	3548	1/1	0.40	0.38	188,188,188,188	0
48	MG	F1	3515	1/1	0.40	0.42	143,143,143,143	0
48	MG	D1	3611	1/1	0.41	0.63	205,205,205,205	0
48	MG	H1	3406	1/1	0.42	0.16	143,143,143,143	0
48	MG	H1	3525	1/1	0.42	0.39	157,157,157,157	0
48	MG	A1	3422	1/1	0.44	0.58	144,144,144,144	0
48	MG	H1	3547	1/1	0.44	0.31	175,175,175,175	0
48	MG	H1	3481	1/1	0.44	0.29	134,134,134,134	0
48	MG	F1	3575	1/1	0.44	0.25	130,130,130,130	0
48	MG	H1	3544	1/1	0.45	0.99	146,146,146,146	0
48	MG	F1	3539	1/1	0.46	1.11	187,187,187,187	0
48	MG	H1	3541	1/1	0.46	0.35	154,154,154,154	0
48	MG	A1	3585	1/1	0.47	0.45	152,152,152,152	0
48	MG	D1	3437	1/1	0.50	0.32	148,148,148,148	0
48	MG	E2	206	1/1	0.51	0.32	151,151,151,151	0
48	MG	D1	3608	1/1	0.52	0.23	115,115,115,115	0
48	MG	H1	3543	1/1	0.52	0.46	183,183,183,183	0
48	MG	A1	3428	1/1	0.52	0.60	159,159,159,159	0
48	MG	D1	3401	1/1	0.53	0.25	109,109,109,109	0
48	MG	H1	3450	1/1	0.53	0.73	156,156,156,156	0
48	MG	H1	3479	1/1	0.53	0.43	132,132,132,132	0
48	MG	F1	3540	1/1	0.53	0.21	111,111,111,111	0
48	MG	E2	205	1/1	0.53	0.60	140,140,140,140	0
48	MG	A1	3573	1/1	0.54	0.47	186,186,186,186	0
48	MG	H1	3409	1/1	0.54	0.55	193,193,193,193	0
48	MG	F1	3490	1/1	0.55	0.22	139,139,139,139	0
48	MG	D1	3606	1/1	0.55	1.19	157,157,157,157	0
48	MG	F1	3419	1/1	0.56	0.11	124,124,124,124	0
48	MG	D1	3624	1/1	0.57	0.61	162,162,162,162	0
48	MG	D1	3470	1/1	0.58	0.38	134,134,134,134	0
48	MG	F1	3522	1/1	0.58	0.18	111,111,111,111	0
48	MG	A1	3430	1/1	0.58	0.50	146,146,146,146	0

*Continued on next page...*



*Continued from previous page...*

Mol	Type	Chain	Res	Atoms	RSCC	RSR	B-factors( $\text{\AA}^2$ )	Q<0.9
48	MG	H1	3412	1/1	0.59	0.89	173,173,173,173	0
48	MG	H1	3414	1/1	0.59	0.54	169,169,169,169	0
48	MG	F1	3421	1/1	0.59	0.35	174,174,174,174	0
48	MG	A1	3556	1/1	0.59	0.18	124,124,124,124	0
48	MG	B3	201	1/1	0.59	0.29	129,129,129,129	0
48	MG	H1	3538	1/1	0.59	0.27	140,140,140,140	0
48	MG	H1	3536	1/1	0.60	0.86	168,168,168,168	0
48	MG	F1	3578	1/1	0.60	0.79	161,161,161,161	0
48	MG	F1	3496	1/1	0.61	0.24	122,122,122,122	0
48	MG	D1	3598	1/1	0.61	0.24	159,159,159,159	0
48	MG	D1	3616	1/1	0.61	0.20	150,150,150,150	0
48	MG	A1	3427	1/1	0.61	0.26	152,152,152,152	0
48	MG	F1	3430	1/1	0.61	0.15	128,128,128,128	0
48	MG	A1	3588	1/1	0.61	0.26	144,144,144,144	0
48	MG	A1	3402	1/1	0.62	0.31	143,143,143,143	0
48	MG	A1	3578	1/1	0.62	0.18	117,117,117,117	0
48	MG	H1	3554	1/1	0.62	0.68	128,128,128,128	0
48	MG	A1	3522	1/1	0.63	1.27	146,146,146,146	0
48	MG	H1	3470	1/1	0.63	0.16	140,140,140,140	0
48	MG	H1	3540	1/1	0.63	0.20	136,136,136,136	0
48	MG	H1	3533	1/1	0.63	1.06	153,153,153,153	0
48	MG	D1	3592	1/1	0.63	0.97	159,159,159,159	0
48	MG	A1	3583	1/1	0.64	0.44	112,112,112,112	0
48	MG	H1	3535	1/1	0.64	0.99	150,150,150,150	0
48	MG	G3	205	1/1	0.64	0.94	171,171,171,171	0
48	MG	G2	205	1/1	0.64	0.18	146,146,146,146	0
48	MG	F1	3414	1/1	0.65	0.20	123,123,123,123	0
48	MG	H1	3401	1/1	0.65	0.12	146,146,146,146	0
48	MG	F1	3509	1/1	0.65	0.34	144,144,144,144	0
48	MG	A1	3417	1/1	0.66	0.28	150,150,150,150	0
48	MG	A1	3593	1/1	0.66	0.72	158,158,158,158	0
48	MG	F1	3469	1/1	0.66	0.16	112,112,112,112	0
48	MG	D1	3605	1/1	0.66	0.13	108,108,108,108	0
48	MG	H1	3415	1/1	0.66	0.13	133,133,133,133	0
48	MG	D1	3446	1/1	0.66	0.83	176,176,176,176	0
48	MG	B2	207	1/1	0.66	0.38	149,149,149,149	0
48	MG	A1	3436	1/1	0.66	0.23	110,110,110,110	0
48	MG	D1	3521	1/1	0.66	0.28	129,129,129,129	0
48	MG	GN	201	1/1	0.66	0.52	212,212,212,212	0
48	MG	H1	3511	1/1	0.66	0.27	140,140,140,140	0
48	MG	H1	3516	1/1	0.66	0.28	129,129,129,129	0
48	MG	BQ	201	1/1	0.66	0.21	122,122,122,122	0

*Continued on next page...*

*Continued from previous page...*

Mol	Type	Chain	Res	Atoms	RSCC	RSR	B-factors(Å <sup>2</sup> )	Q<0.9
48	MG	H1	3402	1/1	0.66	0.23	118,118,118,118	0
48	MG	A1	3515	1/1	0.67	0.25	111,111,111,111	0
48	MG	EN	201	1/1	0.67	0.17	111,111,111,111	0
48	MG	G2	206	1/1	0.67	0.90	174,174,174,174	0
48	MG	F1	3570	1/1	0.67	0.27	113,113,113,113	0
48	MG	F1	3493	1/1	0.67	0.51	145,145,145,145	0
48	MG	D1	3497	1/1	0.67	0.53	151,151,151,151	0
48	MG	H1	3477	1/1	0.68	0.30	103,103,103,103	0
48	MG	B3	203	1/1	0.68	0.23	160,160,160,160	0
48	MG	H1	3532	1/1	0.68	0.39	162,162,162,162	0
48	MG	F1	3577	1/1	0.68	0.26	152,152,152,152	0
48	MG	D1	3548	1/1	0.68	0.96	183,183,183,183	0
48	MG	A1	3592	1/1	0.68	0.30	134,134,134,134	0
48	MG	H1	3550	1/1	0.68	0.44	152,152,152,152	0
48	MG	F1	3566	1/1	0.68	1.27	146,146,146,146	0
48	MG	A1	3580	1/1	0.68	0.21	130,130,130,130	0
48	MG	F1	3583	1/1	0.69	0.18	104,104,104,104	0
48	MG	C3	207	1/1	0.69	0.62	160,160,160,160	0
48	MG	H1	3542	1/1	0.69	0.36	137,137,137,137	0
48	MG	H1	3420	1/1	0.69	0.26	113,113,113,113	0
48	MG	E2	202	1/1	0.69	0.18	89,89,89,89	0
48	MG	F1	3555	1/1	0.70	0.27	168,168,168,168	0
48	MG	A1	3507	1/1	0.70	0.20	129,129,129,129	0
48	MG	D1	3597	1/1	0.70	0.83	158,158,158,158	0
48	MG	H1	3531	1/1	0.70	0.59	157,157,157,157	0
48	MG	A1	3435	1/1	0.71	0.54	151,151,151,151	0
48	MG	D1	3547	1/1	0.71	0.28	109,109,109,109	0
48	MG	A1	3451	1/1	0.71	0.16	146,146,146,146	0
48	MG	D1	3550	1/1	0.71	0.59	136,136,136,136	0
48	MG	D1	3467	1/1	0.72	0.18	123,123,123,123	0
48	MG	A1	3401	1/1	0.72	0.12	108,108,108,108	0
48	MG	F1	3489	1/1	0.72	0.10	85,85,85,85	0
48	MG	A1	3483	1/1	0.72	0.14	83,83,83,83	0
48	MG	D1	3603	1/1	0.72	0.44	125,125,125,125	0
48	MG	D1	3418	1/1	0.72	0.16	114,114,114,114	0
48	MG	D1	3576	1/1	0.72	0.54	150,150,150,150	0
48	MG	F1	3574	1/1	0.72	0.70	161,161,161,161	0
48	MG	D1	3579	1/1	0.72	0.10	97,97,97,97	0
48	MG	D1	3600	1/1	0.73	0.40	123,123,123,123	0
48	MG	F1	3563	1/1	0.73	0.18	124,124,124,124	0
48	MG	A1	3454	1/1	0.73	0.18	101,101,101,101	0
48	MG	H1	3410	1/1	0.73	0.44	192,192,192,192	0

*Continued on next page...*

Continued from previous page...

Mol	Type	Chain	Res	Atoms	RSCC	RSR	B-factors( $\text{\AA}^2$ )	Q<0.9
48	MG	A1	3595	1/1	0.73	1.09	151,151,151,151	0
48	MG	F1	3488	1/1	0.73	0.37	110,110,110,110	0
48	MG	D1	3596	1/1	0.73	0.66	165,165,165,165	0
48	MG	B2	201	1/1	0.73	0.20	119,119,119,119	0
48	MG	D1	3541	1/1	0.73	0.34	114,114,114,114	0
48	MG	D1	3424	1/1	0.74	0.43	150,150,150,150	0
48	MG	H1	3526	1/1	0.74	0.22	94,94,94,94	0
48	MG	D1	3429	1/1	0.74	0.23	113,113,113,113	0
48	MG	A1	3491	1/1	0.74	0.24	125,125,125,125	0
48	MG	H1	3418	1/1	0.74	0.21	141,141,141,141	0
48	MG	F1	3462	1/1	0.74	0.15	118,118,118,118	0
48	MG	A1	3416	1/1	0.74	0.23	140,140,140,140	0
48	MG	E3	206	1/1	0.74	0.35	132,132,132,132	0
48	MG	H1	3521	1/1	0.74	0.29	123,123,123,123	0
48	MG	H1	3524	1/1	0.74	0.57	139,139,139,139	0
48	MG	A1	3449	1/1	0.75	0.23	115,115,115,115	0
48	MG	D1	3434	1/1	0.75	0.63	144,144,144,144	0
48	MG	C3	205	1/1	0.75	1.45	175,175,175,175	0
48	MG	A1	3587	1/1	0.75	1.09	182,182,182,182	0
48	MG	GA	301	1/1	0.75	0.24	142,142,142,142	0
48	MG	A1	3420	1/1	0.75	0.30	155,155,155,155	0
48	MG	A1	3582	1/1	0.75	0.19	110,110,110,110	0
48	MG	A1	3437	1/1	0.75	0.48	141,141,141,141	0
48	MG	EW	202	1/1	0.75	0.20	121,121,121,121	0
48	MG	H1	3408	1/1	0.75	0.30	111,111,111,111	0
48	MG	D1	3625	1/1	0.75	0.39	164,164,164,164	0
48	MG	F1	3560	1/1	0.75	0.47	169,169,169,169	0
48	MG	A1	3576	1/1	0.76	0.40	122,122,122,122	0
48	MG	A1	3414	1/1	0.76	0.19	142,142,142,142	0
48	MG	D1	3583	1/1	0.76	0.32	139,139,139,139	0
48	MG	H1	3537	1/1	0.76	0.18	152,152,152,152	0
48	MG	E3	205	1/1	0.76	0.17	127,127,127,127	0
48	MG	H1	3539	1/1	0.76	0.34	128,128,128,128	0
48	MG	F1	3451	1/1	0.76	0.49	122,122,122,122	0
48	MG	F1	3580	1/1	0.76	0.21	147,147,147,147	0
48	MG	A1	3579	1/1	0.76	0.52	94,94,94,94	0
48	MG	F1	3554	1/1	0.76	0.18	131,131,131,131	0
48	MG	D1	3593	1/1	0.76	0.36	180,180,180,180	0
48	MG	A1	3567	1/1	0.76	0.30	144,144,144,144	0
48	MG	A1	3408	1/1	0.76	0.27	122,122,122,122	0
48	MG	A1	3547	1/1	0.76	0.16	81,81,81,81	0
48	MG	F1	3564	1/1	0.76	0.38	143,143,143,143	0

Continued on next page...

Continued from previous page...

Mol	Type	Chain	Res	Atoms	RSCC	RSR	B-factors( $\text{\AA}^2$ )	Q<0.9
48	MG	D1	3551	1/1	0.76	0.18	142,142,142,142	0
48	MG	D1	3514	1/1	0.77	0.20	128,128,128,128	0
48	MG	F1	3576	1/1	0.77	0.46	142,142,142,142	0
48	MG	F1	3511	1/1	0.77	0.71	154,154,154,154	0
48	MG	A1	3503	1/1	0.77	0.16	95,95,95,95	0
48	MG	F1	3519	1/1	0.77	0.16	65,65,65,65	0
48	MG	DJ	301	1/1	0.77	0.45	150,150,150,150	0
48	MG	H1	3446	1/1	0.77	0.34	120,120,120,120	0
48	MG	D1	3571	1/1	0.77	0.43	130,130,130,130	0
48	MG	D1	3588	1/1	0.77	0.18	156,156,156,156	0
48	MG	F1	3468	1/1	0.77	0.16	103,103,103,103	0
48	MG	A1	3431	1/1	0.78	0.12	90,90,90,90	0
48	MG	D1	3448	1/1	0.78	0.22	125,125,125,125	0
48	MG	H1	3492	1/1	0.78	0.13	96,96,96,96	0
48	MG	A1	3530	1/1	0.78	0.48	149,149,149,149	0
48	MG	F1	3503	1/1	0.78	0.18	129,129,129,129	0
48	MG	H1	3413	1/1	0.78	0.20	117,117,117,117	0
48	MG	H1	3473	1/1	0.78	0.19	123,123,123,123	0
48	MG	A1	3577	1/1	0.78	0.14	104,104,104,104	0
48	MG	H1	3478	1/1	0.78	0.10	114,114,114,114	0
48	MG	B2	202	1/1	0.78	0.12	103,103,103,103	0
48	MG	A1	3433	1/1	0.79	0.10	84,84,84,84	0
48	MG	F1	3483	1/1	0.79	0.32	129,129,129,129	0
48	MG	F1	3448	1/1	0.79	0.15	126,126,126,126	0
48	MG	F1	3550	1/1	0.79	0.21	154,154,154,154	0
48	MG	GP	201	1/1	0.79	0.47	109,109,109,109	0
48	MG	GP	202	1/1	0.79	0.24	137,137,137,137	0
48	MG	A1	3555	1/1	0.79	0.58	128,128,128,128	0
48	MG	FT	101	1/1	0.79	0.11	124,124,124,124	0
48	MG	F1	3572	1/1	0.79	0.36	155,155,155,155	0
48	MG	D1	3427	1/1	0.79	0.26	153,153,153,153	0
48	MG	D1	3442	1/1	0.79	0.35	126,126,126,126	0
48	MG	H1	3486	1/1	0.80	0.15	105,105,105,105	0
48	MG	A1	3591	1/1	0.80	0.27	121,121,121,121	0
48	MG	A1	3472	1/1	0.80	0.63	149,149,149,149	0
48	MG	C3	202	1/1	0.80	0.15	135,135,135,135	0
48	MG	A1	3419	1/1	0.80	0.14	100,100,100,100	0
48	MG	F1	3565	1/1	0.80	0.86	168,168,168,168	0
48	MG	A1	3551	1/1	0.80	0.33	123,123,123,123	0
48	MG	H1	3549	1/1	0.80	0.47	124,124,124,124	0
48	MG	B3	202	1/1	0.80	0.15	113,113,113,113	0
48	MG	D1	3417	1/1	0.80	0.20	132,132,132,132	0

Continued on next page...

*Continued from previous page...*

Mol	Type	Chain	Res	Atoms	RSCC	RSR	B-factors( $\text{\AA}^2$ )	Q<0.9
48	MG	D1	3516	1/1	0.80	0.36	82,82,82,82	0
48	MG	H1	3433	1/1	0.81	0.19	132,132,132,132	0
48	MG	H1	3434	1/1	0.81	0.18	93,93,93,93	0
48	MG	CD	201	1/1	0.81	0.16	93,93,93,93	0
48	MG	D1	3604	1/1	0.81	0.44	141,141,141,141	0
48	MG	D1	3626	1/1	0.81	0.20	137,137,137,137	0
48	MG	F1	3548	1/1	0.81	0.12	106,106,106,106	0
48	MG	D1	3627	1/1	0.81	0.08	119,119,119,119	0
48	MG	F1	3501	1/1	0.81	0.16	116,116,116,116	0
48	MG	C2	206	1/1	0.81	0.31	123,123,123,123	0
48	MG	A1	3589	1/1	0.81	0.13	113,113,113,113	0
48	MG	A1	3425	1/1	0.81	0.16	107,107,107,107	0
48	MG	D1	3586	1/1	0.81	0.16	109,109,109,109	0
48	MG	A1	3586	1/1	0.81	0.72	177,177,177,177	0
48	MG	H1	3553	1/1	0.81	0.39	146,146,146,146	0
48	MG	H1	3503	1/1	0.81	0.26	91,91,91,91	0
48	MG	HT	101	1/1	0.81	0.35	174,174,174,174	0
48	MG	F1	3422	1/1	0.82	0.29	149,149,149,149	0
48	MG	F1	3425	1/1	0.82	0.33	115,115,115,115	0
48	MG	F1	3428	1/1	0.82	0.30	111,111,111,111	0
48	MG	A1	3499	1/1	0.82	0.16	117,117,117,117	0
48	MG	H1	3436	1/1	0.82	0.43	146,146,146,146	0
48	MG	H1	3443	1/1	0.82	0.42	157,157,157,157	0
48	MG	F1	3447	1/1	0.82	0.30	156,156,156,156	0
48	MG	H1	3448	1/1	0.82	0.15	98,98,98,98	0
48	MG	A1	3461	1/1	0.82	0.14	67,67,67,67	0
48	MG	F1	3567	1/1	0.82	0.42	128,128,128,128	0
48	MG	D1	3557	1/1	0.82	0.13	116,116,116,116	0
48	MG	H1	3530	1/1	0.82	0.34	154,154,154,154	0
48	MG	H1	3411	1/1	0.82	0.32	120,120,120,120	0
48	MG	F1	3498	1/1	0.82	0.22	141,141,141,141	0
48	MG	D1	3565	1/1	0.82	0.33	114,114,114,114	0
48	MG	D1	3594	1/1	0.82	0.23	106,106,106,106	0
48	MG	F1	3506	1/1	0.82	0.32	114,114,114,114	0
48	MG	D1	3433	1/1	0.83	0.14	149,149,149,149	0
48	MG	D1	3425	1/1	0.83	0.59	123,123,123,123	0
48	MG	F1	3573	1/1	0.83	0.08	84,84,84,84	0
48	MG	D1	3435	1/1	0.83	0.14	108,108,108,108	0
48	MG	F1	3482	1/1	0.83	0.21	130,130,130,130	0
48	MG	A1	3453	1/1	0.83	0.72	184,184,184,184	0
48	MG	E2	201	1/1	0.83	0.34	156,156,156,156	0
48	MG	F1	3549	1/1	0.83	0.20	125,125,125,125	0

*Continued on next page...*

*Continued from previous page...*

Mol	Type	Chain	Res	Atoms	RSCC	RSR	B-factors( $\text{\AA}^2$ )	Q<0.9
48	MG	A1	3444	1/1	0.83	0.13	126,126,126,126	0
48	MG	H1	3482	1/1	0.83	0.61	162,162,162,162	0
48	MG	D1	3540	1/1	0.83	0.20	139,139,139,139	0
48	MG	D1	3609	1/1	0.83	0.67	120,120,120,120	0
48	MG	D1	3574	1/1	0.83	0.12	80,80,80,80	0
48	MG	D1	3613	1/1	0.83	0.23	120,120,120,120	0
48	MG	H1	3509	1/1	0.83	0.18	143,143,143,143	0
48	MG	D1	3615	1/1	0.83	0.24	132,132,132,132	0
48	MG	D1	3484	1/1	0.83	0.31	96,96,96,96	0
48	MG	H1	3422	1/1	0.83	0.46	151,151,151,151	0
48	MG	G3	204	1/1	0.83	0.36	143,143,143,143	0
48	MG	D1	3485	1/1	0.83	0.17	120,120,120,120	0
48	MG	H1	3552	1/1	0.83	0.18	131,131,131,131	0
48	MG	F1	3453	1/1	0.83	0.23	131,131,131,131	0
48	MG	H1	3438	1/1	0.83	0.29	120,120,120,120	0
48	MG	F1	3461	1/1	0.83	0.49	106,106,106,106	0
48	MG	H1	3462	1/1	0.84	0.36	131,131,131,131	0
48	MG	H1	3465	1/1	0.84	0.42	143,143,143,143	0
48	MG	A1	3412	1/1	0.84	0.33	117,117,117,117	0
48	MG	A1	3409	1/1	0.84	0.14	87,87,87,87	0
48	MG	D1	3607	1/1	0.84	0.30	89,89,89,89	0
48	MG	F1	3464	1/1	0.84	0.23	120,120,120,120	0
48	MG	A1	3565	1/1	0.84	0.13	132,132,132,132	0
48	MG	D1	3530	1/1	0.84	0.16	94,94,94,94	0
48	MG	H1	3417	1/1	0.84	0.11	114,114,114,114	0
48	MG	BN	201	1/1	0.84	0.22	147,147,147,147	0
48	MG	A1	3513	1/1	0.84	0.33	133,133,133,133	0
48	MG	H1	3490	1/1	0.84	0.55	122,122,122,122	0
48	MG	F1	3424	1/1	0.84	0.31	114,114,114,114	0
48	MG	H1	3426	1/1	0.84	0.15	105,105,105,105	0
48	MG	GO	201	1/1	0.84	0.44	141,141,141,141	0
48	MG	E3	203	1/1	0.84	0.17	104,104,104,104	0
48	MG	D1	3614	1/1	0.84	0.19	129,129,129,129	0
48	MG	C2	205	1/1	0.84	0.19	127,127,127,127	0
48	MG	H1	3441	1/1	0.84	0.15	102,102,102,102	0
48	MG	D1	3582	1/1	0.84	0.19	93,93,93,93	0
48	MG	A1	3553	1/1	0.84	0.16	108,108,108,108	0
48	MG	F1	3558	1/1	0.84	0.17	144,144,144,144	0
48	MG	H1	3528	1/1	0.84	0.23	119,119,119,119	0
48	MG	B2	208	1/1	0.84	0.42	138,138,138,138	0
48	MG	F1	3413	1/1	0.85	0.38	110,110,110,110	0
48	MG	H1	3487	1/1	0.85	0.19	122,122,122,122	0

*Continued on next page...*

*Continued from previous page...*

Mol	Type	Chain	Res	Atoms	RSCC	RSR	B-factors(Å <sup>2</sup> )	Q<0.9
48	MG	A1	3594	1/1	0.85	0.28	150,150,150,150	0
48	MG	A1	3528	1/1	0.85	0.37	120,120,120,120	0
48	MG	D1	3426	1/1	0.85	0.38	143,143,143,143	0
48	MG	F1	3545	1/1	0.85	0.21	137,137,137,137	0
48	MG	D1	3482	1/1	0.85	0.15	106,106,106,106	0
48	MG	A1	3450	1/1	0.85	0.20	133,133,133,133	0
48	MG	D1	3534	1/1	0.85	0.20	98,98,98,98	0
48	MG	A1	3569	1/1	0.85	0.09	91,91,91,91	0
48	MG	A1	3571	1/1	0.85	0.24	100,100,100,100	0
48	MG	H1	3546	1/1	0.85	0.27	120,120,120,120	0
48	MG	D1	3580	1/1	0.85	0.11	95,95,95,95	0
48	MG	G2	201	1/1	0.85	0.14	141,141,141,141	0
48	MG	F1	3433	1/1	0.85	0.64	95,95,95,95	0
48	MG	D1	3542	1/1	0.85	0.13	71,71,71,71	0
48	MG	EN	202	1/1	0.85	1.14	238,238,238,238	0
48	MG	D1	3499	1/1	0.85	0.14	118,118,118,118	0
48	MG	D1	3513	1/1	0.85	0.16	89,89,89,89	0
48	MG	F1	3403	1/1	0.85	0.11	96,96,96,96	0
48	MG	D1	3631	1/1	0.85	0.08	78,78,78,78	0
48	MG	F1	3529	1/1	0.86	0.71	140,140,140,140	0
48	MG	H1	3484	1/1	0.86	0.24	166,166,166,166	0
48	MG	F1	3569	1/1	0.86	0.40	130,130,130,130	0
48	MG	F1	3408	1/1	0.86	0.14	82,82,82,82	0
48	MG	D1	3515	1/1	0.86	0.15	106,106,106,106	0
48	MG	F1	3542	1/1	0.86	0.13	107,107,107,107	0
48	MG	F1	3544	1/1	0.86	0.13	97,97,97,97	0
48	MG	GQ	201	1/1	0.86	0.30	102,102,102,102	0
48	MG	D1	3622	1/1	0.86	0.30	133,133,133,133	0
48	MG	A1	3584	1/1	0.86	0.23	125,125,125,125	0
48	MG	H1	3512	1/1	0.86	0.31	121,121,121,121	0
48	MG	F1	3495	1/1	0.86	0.12	83,83,83,83	0
48	MG	A1	3552	1/1	0.86	0.10	97,97,97,97	0
48	MG	D1	3522	1/1	0.86	0.64	162,162,162,162	0
48	MG	D1	3444	1/1	0.86	0.22	139,139,139,139	0
48	MG	F1	3463	1/1	0.86	0.19	100,100,100,100	0
48	MG	D1	3504	1/1	0.86	0.27	98,98,98,98	0
48	MG	CQ	201	1/1	0.86	0.18	127,127,127,127	0
48	MG	DQ	201	1/1	0.86	0.32	118,118,118,118	0
48	MG	F1	3477	1/1	0.86	0.68	146,146,146,146	0
48	MG	D1	3561	1/1	0.86	0.19	57,57,57,57	0
48	MG	D1	3421	1/1	0.86	0.22	126,126,126,126	0
48	MG	D1	3439	1/1	0.87	0.38	146,146,146,146	0

*Continued on next page...*



*Continued from previous page...*

Mol	Type	Chain	Res	Atoms	RSCC	RSR	B-factors( $\text{\AA}^2$ )	Q<0.9
48	MG	A1	3566	1/1	0.87	0.11	75,75,75,75	0
48	MG	F1	3423	1/1	0.87	0.08	56,56,56,56	0
48	MG	F1	3491	1/1	0.87	0.18	96,96,96,96	0
48	MG	F1	3492	1/1	0.87	0.20	78,78,78,78	0
48	MG	H1	3459	1/1	0.87	0.10	97,97,97,97	0
48	MG	D1	3525	1/1	0.87	0.34	113,113,113,113	0
48	MG	A1	3574	1/1	0.87	0.15	119,119,119,119	0
48	MG	D1	3563	1/1	0.87	0.12	93,93,93,93	0
48	MG	D1	3595	1/1	0.87	0.23	94,94,94,94	0
48	MG	D1	3445	1/1	0.87	0.19	126,126,126,126	0
48	MG	F1	3434	1/1	0.87	0.13	83,83,83,83	0
48	MG	D1	3618	1/1	0.87	0.09	95,95,95,95	0
48	MG	D1	3621	1/1	0.87	0.15	110,110,110,110	0
48	MG	D1	3532	1/1	0.87	0.14	119,119,119,119	0
48	MG	D1	3623	1/1	0.87	0.26	151,151,151,151	0
48	MG	A1	3531	1/1	0.87	0.28	128,128,128,128	0
48	MG	F1	3401	1/1	0.87	0.35	101,101,101,101	0
48	MG	F1	3527	1/1	0.87	0.30	105,105,105,105	0
48	MG	H1	3545	1/1	0.87	0.19	156,156,156,156	0
48	MG	D1	3575	1/1	0.87	0.13	124,124,124,124	0
48	MG	F1	3532	1/1	0.87	0.19	87,87,87,87	0
48	MG	F1	3538	1/1	0.87	0.36	113,113,113,113	0
48	MG	A1	3455	1/1	0.87	0.13	111,111,111,111	0
48	MG	D1	3422	1/1	0.87	0.22	150,150,150,150	0
48	MG	A1	3474	1/1	0.87	0.13	88,88,88,88	0
48	MG	F1	3473	1/1	0.87	0.42	156,156,156,156	0
48	MG	DA	102	1/1	0.87	0.20	115,115,115,115	0
48	MG	A1	3497	1/1	0.87	0.12	116,116,116,116	0
48	MG	D1	3475	1/1	0.87	0.51	120,120,120,120	0
48	MG	H1	3407	1/1	0.88	0.20	105,105,105,105	0
48	MG	A1	3404	1/1	0.88	0.12	94,94,94,94	0
48	MG	F1	3500	1/1	0.88	0.17	105,105,105,105	0
48	MG	B2	206	1/1	0.88	0.45	139,139,139,139	0
48	MG	H1	3472	1/1	0.88	0.32	104,104,104,104	0
48	MG	D1	3496	1/1	0.88	0.16	78,78,78,78	0
48	MG	A1	3424	1/1	0.88	0.37	150,150,150,150	0
48	MG	F1	3556	1/1	0.88	0.08	90,90,90,90	0
48	MG	D1	3498	1/1	0.88	0.47	99,99,99,99	0
48	MG	D1	3620	1/1	0.88	0.15	106,106,106,106	0
48	MG	D1	3599	1/1	0.88	0.27	126,126,126,126	0
48	MG	G3	201	1/1	0.88	0.12	119,119,119,119	0
48	MG	H1	3485	1/1	0.88	0.12	104,104,104,104	0

*Continued on next page...*



*Continued from previous page...*

Mol	Type	Chain	Res	Atoms	RSCC	RSR	B-factors( $\text{\AA}^2$ )	Q<0.9
48	MG	F1	3516	1/1	0.88	0.30	121,121,121,121	0
48	MG	A1	3554	1/1	0.88	0.14	76,76,76,76	0
48	MG	H1	3425	1/1	0.88	0.31	108,108,108,108	0
48	MG	D1	3602	1/1	0.88	0.19	118,118,118,118	0
48	MG	F1	3485	1/1	0.88	0.16	117,117,117,117	0
48	MG	A1	3516	1/1	0.88	0.23	88,88,88,88	0
48	MG	H1	3504	1/1	0.88	0.11	111,111,111,111	0
48	MG	D1	3505	1/1	0.88	0.16	84,84,84,84	0
48	MG	H1	3510	1/1	0.88	0.24	120,120,120,120	0
48	MG	A1	3536	1/1	0.88	0.14	104,104,104,104	0
48	MG	A1	3542	1/1	0.88	0.22	96,96,96,96	0
48	MG	CW	201	1/1	0.88	0.29	90,90,90,90	0
48	MG	A1	3415	1/1	0.88	0.20	120,120,120,120	0
48	MG	BP	200	1/1	0.88	0.10	123,123,123,123	0
48	MG	A1	3512	1/1	0.88	0.10	90,90,90,90	0
48	MG	H1	3452	1/1	0.88	0.10	108,108,108,108	0
48	MG	D1	3523	1/1	0.89	0.10	105,105,105,105	0
48	MG	A1	3563	1/1	0.89	0.13	100,100,100,100	0
48	MG	A1	3423	1/1	0.89	0.21	115,115,115,115	0
48	MG	A1	3492	1/1	0.89	0.28	127,127,127,127	0
48	MG	F1	3502	1/1	0.89	0.26	108,108,108,108	0
48	MG	A1	3438	1/1	0.89	0.23	148,148,148,148	0
48	MG	H1	3404	1/1	0.89	0.11	132,132,132,132	0
48	MG	A1	3479	1/1	0.89	0.22	120,120,120,120	0
48	MG	C2	201	1/1	0.89	0.15	121,121,121,121	0
48	MG	H1	3496	1/1	0.89	0.44	141,141,141,141	0
48	MG	H1	3499	1/1	0.89	0.11	75,75,75,75	0
48	MG	H1	3501	1/1	0.89	0.30	110,110,110,110	0
48	MG	F1	3431	1/1	0.89	0.17	103,103,103,103	0
48	MG	D1	3468	1/1	0.89	0.13	75,75,75,75	0
48	MG	F1	3559	1/1	0.89	0.10	133,133,133,133	0
48	MG	F1	3484	1/1	0.89	0.17	78,78,78,78	0
48	MG	D1	3577	1/1	0.89	0.22	121,121,121,121	0
48	MG	H1	3464	1/1	0.89	0.15	108,108,108,108	0
48	MG	F1	3446	1/1	0.89	0.20	130,130,130,130	0
48	MG	H1	3468	1/1	0.89	0.23	121,121,121,121	0
48	MG	A1	3532	1/1	0.89	0.07	74,74,74,74	0
48	MG	A1	3590	1/1	0.89	0.26	142,142,142,142	0
48	MG	A1	3500	1/1	0.89	0.30	89,89,89,89	0
48	MG	D1	3440	1/1	0.89	0.12	99,99,99,99	0
48	MG	F1	3456	1/1	0.89	0.07	62,62,62,62	0
48	MG	H1	3555	1/1	0.89	0.15	123,123,123,123	0

*Continued on next page...*

*Continued from previous page...*

Mol	Type	Chain	Res	Atoms	RSCC	RSR	B-factors( $\text{\AA}^2$ )	Q<0.9
48	MG	A1	3470	1/1	0.89	0.32	164,164,164,164	0
48	MG	A1	3443	1/1	0.90	0.14	90,90,90,90	0
48	MG	C2	202	1/1	0.90	0.23	112,112,112,112	0
48	MG	F1	3553	1/1	0.90	0.09	68,68,68,68	0
48	MG	H1	3442	1/1	0.90	0.09	79,79,79,79	0
48	MG	H1	3518	1/1	0.90	0.15	110,110,110,110	0
48	MG	A1	3596	1/1	0.90	0.30	163,163,163,163	0
48	MG	F1	3457	1/1	0.90	0.27	91,91,91,91	0
48	MG	H1	3523	1/1	0.90	0.12	167,167,167,167	0
48	MG	A1	3600	1/1	0.90	0.11	111,111,111,111	0
48	MG	H1	3449	1/1	0.90	0.62	118,118,118,118	0
48	MG	A1	3575	1/1	0.90	0.62	143,143,143,143	0
48	MG	C3	203	1/1	0.90	0.08	69,69,69,69	0
48	MG	H1	3457	1/1	0.90	0.56	147,147,147,147	0
48	MG	A1	3510	1/1	0.90	0.21	109,109,109,109	0
48	MG	E2	207	1/1	0.90	0.41	147,147,147,147	0
48	MG	D1	3535	1/1	0.90	0.17	86,86,86,86	0
48	MG	F1	3513	1/1	0.90	0.17	79,79,79,79	0
48	MG	F1	3472	1/1	0.90	0.15	111,111,111,111	0
48	MG	D1	3538	1/1	0.90	0.10	119,119,119,119	0
48	MG	F1	3475	1/1	0.90	0.17	93,93,93,93	0
48	MG	D1	3511	1/1	0.90	0.24	118,118,118,118	0
48	MG	D1	3472	1/1	0.90	0.10	82,82,82,82	0
48	MG	EL	302	1/1	0.90	0.09	68,68,68,68	0
48	MG	A1	3471	1/1	0.90	0.31	88,88,88,88	0
48	MG	F1	3534	1/1	0.90	0.08	79,79,79,79	0
48	MG	F1	3535	1/1	0.90	0.11	58,58,58,58	0
48	MG	F1	3537	1/1	0.90	0.21	136,136,136,136	0
48	MG	D1	3481	1/1	0.90	0.39	114,114,114,114	0
48	MG	A1	3529	1/1	0.90	0.10	96,96,96,96	0
48	MG	F1	3579	1/1	0.90	0.12	166,166,166,166	0
48	MG	H1	3488	1/1	0.90	0.19	108,108,108,108	0
48	MG	F1	3439	1/1	0.90	0.09	62,62,62,62	0
48	MG	F1	3581	1/1	0.90	0.38	144,144,144,144	0
48	MG	F1	3541	1/1	0.90	0.23	112,112,112,112	0
48	MG	F1	3440	1/1	0.90	0.11	82,82,82,82	0
48	MG	D1	3549	1/1	0.90	0.13	99,99,99,99	0
48	MG	H1	3430	1/1	0.90	0.20	82,82,82,82	0
48	MG	D1	3628	1/1	0.90	0.07	107,107,107,107	0
48	MG	CL	301	1/1	0.90	0.15	109,109,109,109	0
48	MG	H1	3435	1/1	0.90	0.17	116,116,116,116	0
49	ZN	HC	201	1/1	0.90	0.04	168,168,168,168	0

*Continued on next page...*

*Continued from previous page...*

Mol	Type	Chain	Res	Atoms	RSCC	RSR	B-factors(Å <sup>2</sup> )	Q<0.9
48	MG	E3	202	1/1	0.91	0.20	122,122,122,122	0
48	MG	F1	3429	1/1	0.91	0.17	73,73,73,73	0
48	MG	D1	3543	1/1	0.91	0.27	127,127,127,127	0
48	MG	F1	3568	1/1	0.91	0.13	98,98,98,98	0
48	MG	GW	201	1/1	0.91	0.22	114,114,114,114	0
48	MG	H1	3455	1/1	0.91	0.14	113,113,113,113	0
48	MG	H1	3456	1/1	0.91	0.76	145,145,145,145	0
48	MG	D1	3545	1/1	0.91	0.15	88,88,88,88	0
48	MG	A1	3498	1/1	0.91	0.11	116,116,116,116	0
48	MG	F1	3571	1/1	0.91	0.29	132,132,132,132	0
48	MG	A1	3447	1/1	0.91	0.13	58,58,58,58	0
48	MG	D1	3476	1/1	0.91	0.08	43,43,43,43	0
48	MG	D1	3441	1/1	0.91	0.15	75,75,75,75	0
48	MG	A1	3403	1/1	0.91	0.13	96,96,96,96	0
48	MG	A1	3496	1/1	0.91	0.24	137,137,137,137	0
48	MG	CY	201	1/1	0.91	0.20	99,99,99,99	0
48	MG	A1	3467	1/1	0.91	0.19	106,106,106,106	0
48	MG	D1	3447	1/1	0.91	0.23	101,101,101,101	0
48	MG	F1	3497	1/1	0.91	0.12	93,93,93,93	0
48	MG	D1	3568	1/1	0.91	0.17	105,105,105,105	0
48	MG	H1	3416	1/1	0.91	0.66	113,113,113,113	0
48	MG	D1	3406	1/1	0.91	0.14	67,67,67,67	0
48	MG	FA	101	1/1	0.91	0.11	97,97,97,97	0
48	MG	FK	201	1/1	0.91	0.50	168,168,168,168	0
48	MG	D1	3572	1/1	0.91	0.23	69,69,69,69	0
48	MG	D1	3573	1/1	0.91	0.14	126,126,126,126	0
48	MG	G2	202	1/1	0.91	0.34	122,122,122,122	0
48	MG	H1	3429	1/1	0.91	0.14	87,87,87,87	0
48	MG	D1	3409	1/1	0.91	0.13	57,57,57,57	0
48	MG	H1	3432	1/1	0.91	0.09	91,91,91,91	0
48	MG	D1	3416	1/1	0.91	0.24	110,110,110,110	0
48	MG	F1	3466	1/1	0.91	0.34	140,140,140,140	0
48	MG	A1	3572	1/1	0.91	0.23	121,121,121,121	0
48	MG	D1	3506	1/1	0.91	0.30	132,132,132,132	0
48	MG	D1	3507	1/1	0.91	0.10	75,75,75,75	0
48	MG	A1	3519	1/1	0.91	0.10	113,113,113,113	0
48	MG	D1	3512	1/1	0.91	0.14	101,101,101,101	0
48	MG	F1	3520	1/1	0.91	0.19	85,85,85,85	0
48	MG	D1	3581	1/1	0.92	0.08	68,68,68,68	0
48	MG	H1	3505	1/1	0.92	0.11	95,95,95,95	0
48	MG	H1	3508	1/1	0.92	0.16	80,80,80,80	0
48	MG	G3	203	1/1	0.92	0.13	86,86,86,86	0

*Continued on next page...*

*Continued from previous page...*

Mol	Type	Chain	Res	Atoms	RSCC	RSR	B-factors( $\text{\AA}^2$ )	Q<0.9
48	MG	D1	3451	1/1	0.92	0.42	115,115,115,115	0
48	MG	D1	3452	1/1	0.92	0.15	106,106,106,106	0
48	MG	A1	3518	1/1	0.92	0.24	109,109,109,109	0
48	MG	A1	3509	1/1	0.92	0.12	128,128,128,128	0
48	MG	F1	3562	1/1	0.92	0.40	140,140,140,140	0
48	MG	H1	3447	1/1	0.92	0.25	110,110,110,110	0
48	MG	D1	3432	1/1	0.92	0.17	118,118,118,118	0
48	MG	F1	3402	1/1	0.92	0.09	83,83,83,83	0
48	MG	AK	202	1/1	0.92	0.72	179,179,179,179	0
48	MG	F1	3407	1/1	0.92	0.10	111,111,111,111	0
48	MG	D1	3403	1/1	0.92	0.07	89,89,89,89	0
48	MG	F1	3517	1/1	0.92	0.11	62,62,62,62	0
48	MG	H1	3403	1/1	0.92	0.14	111,111,111,111	0
48	MG	A1	3521	1/1	0.92	0.12	105,105,105,105	0
48	MG	D1	3552	1/1	0.92	0.06	55,55,55,55	0
48	MG	D1	3517	1/1	0.92	0.31	127,127,127,127	0
48	MG	F1	3470	1/1	0.92	0.09	49,49,49,49	0
48	MG	H1	3467	1/1	0.92	0.11	95,95,95,95	0
48	MG	D1	3407	1/1	0.92	0.09	70,70,70,70	0
48	MG	D1	3562	1/1	0.92	0.22	93,93,93,93	0
48	MG	A1	3429	1/1	0.92	0.11	122,122,122,122	0
48	MG	B2	204	1/1	0.92	0.08	85,85,85,85	0
48	MG	H1	3474	1/1	0.92	0.09	123,123,123,123	0
48	MG	A1	3548	1/1	0.92	0.17	124,124,124,124	0
48	MG	A1	3511	1/1	0.92	0.08	90,90,90,90	0
48	MG	D1	3491	1/1	0.92	0.15	97,97,97,97	0
48	MG	H1	3480	1/1	0.92	0.14	81,81,81,81	0
48	MG	D1	3443	1/1	0.92	0.48	112,112,112,112	0
48	MG	A1	3468	1/1	0.92	0.18	109,109,109,109	0
48	MG	A1	3581	1/1	0.92	0.32	126,126,126,126	0
48	MG	F1	3543	1/1	0.92	0.09	71,71,71,71	0
48	MG	D1	3537	1/1	0.92	0.28	121,121,121,121	0
48	MG	H1	3424	1/1	0.92	0.08	96,96,96,96	0
48	MG	D1	3610	1/1	0.92	0.21	66,66,66,66	0
48	MG	A1	3501	1/1	0.92	0.22	102,102,102,102	0
48	MG	A1	3490	1/1	0.92	0.21	105,105,105,105	0
48	MG	A1	3464	1/1	0.92	0.06	64,64,64,64	0
48	MG	H1	3431	1/1	0.92	0.25	94,94,94,94	0
48	MG	F1	3442	1/1	0.92	0.27	109,109,109,109	0
48	MG	F1	3444	1/1	0.92	0.42	155,155,155,155	0
48	MG	EL	301	1/1	0.92	0.12	119,119,119,119	0
48	MG	H1	3451	1/1	0.93	0.13	78,78,78,78	0

*Continued on next page...*

*Continued from previous page...*

Mol	Type	Chain	Res	Atoms	RSCC	RSR	B-factors( $\text{\AA}^2$ )	Q<0.9
48	MG	H1	3405	1/1	0.93	0.25	101,101,101,101	0
48	MG	H1	3513	1/1	0.93	0.11	87,87,87,87	0
48	MG	F1	3479	1/1	0.93	0.29	81,81,81,81	0
48	MG	H1	3517	1/1	0.93	0.16	79,79,79,79	0
48	MG	A1	3560	1/1	0.93	0.45	138,138,138,138	0
48	MG	A1	3562	1/1	0.93	0.20	91,91,91,91	0
48	MG	H1	3520	1/1	0.93	0.17	114,114,114,114	0
48	MG	A1	3549	1/1	0.93	0.13	54,54,54,54	0
48	MG	H1	3522	1/1	0.93	0.16	107,107,107,107	0
48	MG	H1	3461	1/1	0.93	0.15	134,134,134,134	0
48	MG	D1	3585	1/1	0.93	0.08	108,108,108,108	0
48	MG	A1	3564	1/1	0.93	0.07	141,141,141,141	0
48	MG	F1	3436	1/1	0.93	0.10	70,70,70,70	0
48	MG	H1	3527	1/1	0.93	0.14	99,99,99,99	0
48	MG	A1	3493	1/1	0.93	0.21	113,113,113,113	0
48	MG	D1	3412	1/1	0.93	0.35	95,95,95,95	0
48	MG	D1	3414	1/1	0.93	0.15	96,96,96,96	0
48	MG	A1	3488	1/1	0.93	0.17	91,91,91,91	0
48	MG	FA	102	1/1	0.93	0.10	84,84,84,84	0
48	MG	F1	3494	1/1	0.93	0.12	97,97,97,97	0
48	MG	H1	3419	1/1	0.93	0.17	62,62,62,62	0
48	MG	D1	3520	1/1	0.93	0.11	93,93,93,93	0
48	MG	A1	3541	1/1	0.93	0.35	86,86,86,86	0
48	MG	F1	3551	1/1	0.93	0.24	91,91,91,91	0
48	MG	C3	204	1/1	0.93	0.11	85,85,85,85	0
48	MG	F1	3405	1/1	0.93	0.13	79,79,79,79	0
48	MG	F1	3406	1/1	0.93	0.08	83,83,83,83	0
48	MG	F1	3455	1/1	0.93	0.09	65,65,65,65	0
48	MG	A1	3475	1/1	0.93	0.22	80,80,80,80	0
48	MG	D1	3487	1/1	0.93	0.09	65,65,65,65	0
48	MG	F1	3458	1/1	0.93	0.09	95,95,95,95	0
48	MG	D1	3527	1/1	0.93	0.28	106,106,106,106	0
48	MG	A1	3441	1/1	0.93	0.50	127,127,127,127	0
48	MG	D1	3494	1/1	0.93	0.13	78,78,78,78	0
48	MG	H1	3495	1/1	0.93	0.06	65,65,65,65	0
48	MG	D1	3531	1/1	0.93	0.08	87,87,87,87	0
48	MG	A1	3570	1/1	0.93	0.08	70,70,70,70	0
48	MG	F1	3420	1/1	0.93	0.09	88,88,88,88	0
48	MG	A1	3439	1/1	0.93	0.08	106,106,106,106	0
48	MG	BL	301	1/1	0.93	0.09	71,71,71,71	0
48	MG	A1	3559	1/1	0.93	0.06	89,89,89,89	0
48	MG	A1	3599	1/1	0.93	0.12	103,103,103,103	0

*Continued on next page...*

*Continued from previous page...*

Mol	Type	Chain	Res	Atoms	RSCC	RSR	B-factors( $\text{\AA}^2$ )	Q<0.9
48	MG	D1	3454	1/1	0.93	0.14	64,64,64,64	0
48	MG	D1	3458	1/1	0.93	0.06	51,51,51,51	0
48	MG	H1	3428	1/1	0.94	0.12	77,77,77,77	0
48	MG	F1	3531	1/1	0.94	0.09	95,95,95,95	0
48	MG	A1	3504	1/1	0.94	0.49	138,138,138,138	0
48	MG	F1	3533	1/1	0.94	0.18	101,101,101,101	0
48	MG	F1	3417	1/1	0.94	0.17	110,110,110,110	0
48	MG	F1	3471	1/1	0.94	0.17	90,90,90,90	0
48	MG	F1	3536	1/1	0.94	0.20	67,67,67,67	0
48	MG	F1	3418	1/1	0.94	0.12	126,126,126,126	0
48	MG	DA	101	1/1	0.94	0.07	82,82,82,82	0
48	MG	D1	3564	1/1	0.94	0.21	92,92,92,92	0
48	MG	H1	3440	1/1	0.94	0.08	73,73,73,73	0
48	MG	A1	3505	1/1	0.94	0.12	137,137,137,137	0
48	MG	F1	3478	1/1	0.94	0.12	73,73,73,73	0
48	MG	D1	3601	1/1	0.94	0.22	124,124,124,124	0
48	MG	F1	3480	1/1	0.94	0.12	59,59,59,59	0
48	MG	D1	3431	1/1	0.94	0.19	95,95,95,95	0
48	MG	D1	3455	1/1	0.94	0.09	80,80,80,80	0
48	MG	E2	203	1/1	0.94	0.07	77,77,77,77	0
48	MG	B2	205	1/1	0.94	0.09	81,81,81,81	0
48	MG	A1	3407	1/1	0.94	0.11	83,83,83,83	0
48	MG	C3	201	1/1	0.94	0.34	123,123,123,123	0
48	MG	H1	3454	1/1	0.94	0.12	111,111,111,111	0
48	MG	A1	3448	1/1	0.94	0.14	78,78,78,78	0
48	MG	D1	3508	1/1	0.94	0.05	86,86,86,86	0
48	MG	D1	3413	1/1	0.94	0.09	51,51,51,51	0
48	MG	A1	3533	1/1	0.94	0.22	73,73,73,73	0
48	MG	F1	3557	1/1	0.94	0.15	84,84,84,84	0
48	MG	F1	3437	1/1	0.94	0.17	100,100,100,100	0
48	MG	A1	3481	1/1	0.94	0.16	88,88,88,88	0
48	MG	EJ	201	1/1	0.94	0.12	69,69,69,69	0
48	MG	D1	3612	1/1	0.94	0.23	123,123,123,123	0
48	MG	F1	3443	1/1	0.94	0.06	104,104,104,104	0
48	MG	H1	3469	1/1	0.94	0.34	119,119,119,119	0
48	MG	A1	3405	1/1	0.94	0.08	65,65,65,65	0
48	MG	H1	3471	1/1	0.94	0.21	124,124,124,124	0
48	MG	D1	3478	1/1	0.94	0.12	81,81,81,81	0
48	MG	A1	3494	1/1	0.94	0.07	98,98,98,98	0
48	MG	D1	3584	1/1	0.94	0.13	101,101,101,101	0
48	MG	H1	3475	1/1	0.94	0.10	70,70,70,70	0
48	MG	D1	3617	1/1	0.94	0.34	113,113,113,113	0

*Continued on next page...*

*Continued from previous page...*

Mol	Type	Chain	Res	Atoms	RSCC	RSR	B-factors( $\text{\AA}^2$ )	Q<0.9
48	MG	F1	3507	1/1	0.94	0.17	87,87,87,87	0
48	MG	BJ	201	1/1	0.94	0.17	66,66,66,66	0
48	MG	AA	102	1/1	0.94	0.08	98,98,98,98	0
48	MG	D1	3423	1/1	0.94	0.17	67,67,67,67	0
48	MG	D1	3589	1/1	0.94	0.26	107,107,107,107	0
48	MG	AA	103	1/1	0.94	0.08	56,56,56,56	0
48	MG	D1	3553	1/1	0.94	0.07	90,90,90,90	0
48	MG	A1	3558	1/1	0.94	0.10	91,91,91,91	0
48	MG	F1	3410	1/1	0.94	0.17	42,42,42,42	0
48	MG	D1	3558	1/1	0.94	0.07	56,56,56,56	0
48	MG	D1	3492	1/1	0.94	0.34	125,125,125,125	0
48	MG	A1	3469	1/1	0.94	0.17	113,113,113,113	0
48	MG	F1	3530	1/1	0.94	0.15	107,107,107,107	0
48	MG	H1	3427	1/1	0.94	0.14	83,83,83,83	0
48	MG	H1	3423	1/1	0.95	0.11	98,98,98,98	0
48	MG	D1	3474	1/1	0.95	0.10	58,58,58,58	0
48	MG	A1	3434	1/1	0.95	0.16	74,74,74,74	0
48	MG	H1	3491	1/1	0.95	0.13	111,111,111,111	0
48	MG	F1	3524	1/1	0.95	0.14	56,56,56,56	0
48	MG	A1	3550	1/1	0.95	0.04	69,69,69,69	0
48	MG	D1	3524	1/1	0.95	0.06	69,69,69,69	0
48	MG	D1	3477	1/1	0.95	0.09	60,60,60,60	0
48	MG	H1	3500	1/1	0.95	0.16	82,82,82,82	0
48	MG	F1	3582	1/1	0.95	0.20	77,77,77,77	0
48	MG	D1	3402	1/1	0.95	0.08	52,52,52,52	0
48	MG	F1	3584	1/1	0.95	0.16	97,97,97,97	0
48	MG	A1	3484	1/1	0.95	0.13	108,108,108,108	0
48	MG	H1	3507	1/1	0.95	0.07	64,64,64,64	0
48	MG	A1	3485	1/1	0.95	0.15	137,137,137,137	0
48	MG	D1	3483	1/1	0.95	0.09	88,88,88,88	0
48	MG	F1	3412	1/1	0.95	0.11	60,60,60,60	0
48	MG	A1	3486	1/1	0.95	0.15	93,93,93,93	0
48	MG	D1	3408	1/1	0.95	0.30	106,106,106,106	0
48	MG	A1	3487	1/1	0.95	0.23	121,121,121,121	0
48	MG	F1	3416	1/1	0.95	0.45	116,116,116,116	0
48	MG	D1	3488	1/1	0.95	0.18	97,97,97,97	0
48	MG	A1	3445	1/1	0.95	0.18	88,88,88,88	0
48	MG	A1	3506	1/1	0.95	0.12	77,77,77,77	0
48	MG	F1	3481	1/1	0.95	0.13	45,45,45,45	0
48	MG	A1	3411	1/1	0.95	0.17	83,83,83,83	0
48	MG	D1	3629	1/1	0.95	0.11	121,121,121,121	0
48	MG	D1	3415	1/1	0.95	0.11	117,117,117,117	0

*Continued on next page...*



*Continued from previous page...*

Mol	Type	Chain	Res	Atoms	RSCC	RSR	B-factors( $\text{\AA}^2$ )	Q<0.9
48	MG	GJ	201	1/1	0.95	0.13	69,69,69,69	0
48	MG	GL	301	1/1	0.95	0.11	113,113,113,113	0
48	MG	D1	3590	1/1	0.95	0.20	89,89,89,89	0
48	MG	D1	3591	1/1	0.95	0.10	55,55,55,55	0
48	MG	A1	3508	1/1	0.95	0.12	89,89,89,89	0
48	MG	F1	3552	1/1	0.95	0.15	139,139,139,139	0
48	MG	H1	3460	1/1	0.95	0.13	69,69,69,69	0
48	MG	DK	201	1/1	0.95	0.29	101,101,101,101	0
48	MG	A1	3406	1/1	0.95	0.10	75,75,75,75	0
48	MG	H1	3463	1/1	0.95	0.11	78,78,78,78	0
48	MG	A1	3477	1/1	0.95	0.13	62,62,62,62	0
48	MG	D1	3449	1/1	0.95	0.09	68,68,68,68	0
48	MG	H1	3466	1/1	0.95	0.08	107,107,107,107	0
48	MG	D1	3450	1/1	0.95	0.07	49,49,49,49	0
48	MG	D1	3419	1/1	0.95	0.10	92,92,92,92	0
48	MG	A1	3535	1/1	0.95	0.09	99,99,99,99	0
48	MG	A1	3478	1/1	0.95	0.08	79,79,79,79	0
48	MG	E3	201	1/1	0.95	0.09	90,90,90,90	0
48	MG	D1	3510	1/1	0.95	0.19	81,81,81,81	0
48	MG	D1	3555	1/1	0.95	0.39	119,119,119,119	0
48	MG	A1	3418	1/1	0.95	0.10	117,117,117,117	0
48	MG	D1	3457	1/1	0.95	0.12	34,34,34,34	0
48	MG	H1	3476	1/1	0.95	0.08	52,52,52,52	0
48	MG	F1	3504	1/1	0.95	0.13	84,84,84,84	0
48	MG	A1	3480	1/1	0.95	0.31	120,120,120,120	0
48	MG	A1	3544	1/1	0.95	0.48	135,135,135,135	0
48	MG	A1	3545	1/1	0.95	0.30	71,71,71,71	0
48	MG	CN	201	1/1	0.95	0.29	175,175,175,175	0
48	MG	F1	3452	1/1	0.95	0.10	50,50,50,50	0
48	MG	H1	3483	1/1	0.95	0.14	108,108,108,108	0
48	MG	A1	3459	1/1	0.95	0.20	90,90,90,90	0
48	MG	D1	3566	1/1	0.95	0.14	80,80,80,80	0
48	MG	D1	3567	1/1	0.95	0.26	60,60,60,60	0
48	MG	A1	3482	1/1	0.95	0.06	62,62,62,62	0
48	MG	H1	3502	1/1	0.96	0.07	82,82,82,82	0
48	MG	D1	3493	1/1	0.96	0.33	128,128,128,128	0
48	MG	A1	3523	1/1	0.96	0.12	91,91,91,91	0
48	MG	D1	3526	1/1	0.96	0.05	54,54,54,54	0
48	MG	D1	3495	1/1	0.96	0.07	88,88,88,88	0
48	MG	D1	3465	1/1	0.96	0.09	65,65,65,65	0
48	MG	D1	3529	1/1	0.96	0.10	80,80,80,80	0
48	MG	H1	3453	1/1	0.96	0.11	66,66,66,66	0

*Continued on next page...*



*Continued from previous page...*

Mol	Type	Chain	Res	Atoms	RSCC	RSR	B-factors(Å <sup>2</sup> )	Q<0.9
48	MG	F1	3508	1/1	0.96	0.24	127,127,127,127	0
48	MG	D1	3466	1/1	0.96	0.22	132,132,132,132	0
48	MG	F1	3465	1/1	0.96	0.26	101,101,101,101	0
48	MG	H1	3514	1/1	0.96	0.07	66,66,66,66	0
48	MG	F1	3512	1/1	0.96	0.11	94,94,94,94	0
48	MG	C3	206	1/1	0.96	0.15	120,120,120,120	0
48	MG	F1	3514	1/1	0.96	0.13	70,70,70,70	0
48	MG	A1	3465	1/1	0.96	0.08	54,54,54,54	0
48	MG	D1	3500	1/1	0.96	0.09	44,44,44,44	0
48	MG	A1	3462	1/1	0.96	0.10	46,46,46,46	0
48	MG	F1	3518	1/1	0.96	0.13	77,77,77,77	0
48	MG	CJ	201	1/1	0.96	0.14	64,64,64,64	0
48	MG	D1	3473	1/1	0.96	0.11	63,63,63,63	0
48	MG	F1	3521	1/1	0.96	0.09	65,65,65,65	0
48	MG	D1	3539	1/1	0.96	0.14	57,57,57,57	0
48	MG	D1	3578	1/1	0.96	0.07	88,88,88,88	0
48	MG	F1	3526	1/1	0.96	0.14	72,72,72,72	0
48	MG	F1	3476	1/1	0.96	0.16	99,99,99,99	0
48	MG	A1	3537	1/1	0.96	0.12	54,54,54,54	0
48	MG	A1	3539	1/1	0.96	0.08	46,46,46,46	0
48	MG	A1	3463	1/1	0.96	0.10	59,59,59,59	0
48	MG	A1	3520	1/1	0.96	0.16	70,70,70,70	0
48	MG	D1	3544	1/1	0.96	0.09	50,50,50,50	0
48	MG	A1	3514	1/1	0.96	0.14	59,59,59,59	0
48	MG	A1	3442	1/1	0.96	0.10	52,52,52,52	0
48	MG	D1	3619	1/1	0.96	0.07	101,101,101,101	0
48	MG	EQ	201	1/1	0.96	0.18	88,88,88,88	0
48	MG	F1	3486	1/1	0.96	0.11	90,90,90,90	0
48	MG	F1	3487	1/1	0.96	0.09	60,60,60,60	0
48	MG	D1	3436	1/1	0.96	0.16	78,78,78,78	0
48	MG	A1	3546	1/1	0.96	0.23	51,51,51,51	0
48	MG	D1	3438	1/1	0.96	0.08	39,39,39,39	0
48	MG	G2	203	1/1	0.96	0.10	112,112,112,112	0
48	MG	A1	3557	1/1	0.96	0.20	104,104,104,104	0
48	MG	F1	3445	1/1	0.96	0.16	78,78,78,78	0
48	MG	D1	3518	1/1	0.96	0.21	92,92,92,92	0
48	MG	F1	3547	1/1	0.96	0.10	112,112,112,112	0
48	MG	D1	3519	1/1	0.96	0.08	72,72,72,72	0
48	MG	D1	3404	1/1	0.96	0.11	55,55,55,55	0
48	MG	H1	3494	1/1	0.96	0.14	56,56,56,56	0
48	MG	D1	3459	1/1	0.96	0.07	63,63,63,63	0
48	MG	D1	3460	1/1	0.96	0.09	85,85,85,85	0

*Continued on next page...*

*Continued from previous page...*

Mol	Type	Chain	Res	Atoms	RSCC	RSR	B-factors(Å <sup>2</sup> )	Q<0.9
48	MG	H1	3498	1/1	0.96	0.07	60,60,60,60	0
48	MG	F1	3409	1/1	0.96	0.16	60,60,60,60	0
48	MG	H1	3445	1/1	0.96	0.14	68,68,68,68	0
49	ZN	AC	201	1/1	0.96	0.08	143,143,143,143	0
49	ZN	FL	201	1/1	0.96	0.09	86,86,86,86	0
48	MG	D1	3461	1/1	0.96	0.10	86,86,86,86	0
48	MG	D1	3464	1/1	0.97	0.08	44,44,44,44	0
48	MG	A1	3458	1/1	0.97	0.10	59,59,59,59	0
48	MG	F1	3441	1/1	0.97	0.19	111,111,111,111	0
48	MG	H1	3506	1/1	0.97	0.12	75,75,75,75	0
48	MG	A1	3526	1/1	0.97	0.10	48,48,48,48	0
48	MG	A1	3538	1/1	0.97	0.08	49,49,49,49	0
48	MG	D1	3501	1/1	0.97	0.13	51,51,51,51	0
48	MG	D1	3536	1/1	0.97	0.10	73,73,73,73	0
48	MG	D1	3503	1/1	0.97	0.14	82,82,82,82	0
48	MG	A1	3466	1/1	0.97	0.12	40,40,40,40	0
48	MG	CL	302	1/1	0.97	0.10	68,68,68,68	0
48	MG	F1	3449	1/1	0.97	0.10	90,90,90,90	0
48	MG	H1	3515	1/1	0.97	0.09	73,73,73,73	0
48	MG	D1	3420	1/1	0.97	0.08	105,105,105,105	0
48	MG	A1	3540	1/1	0.97	0.15	66,66,66,66	0
48	MG	BQ	202	1/1	0.97	0.07	53,53,53,53	0
48	MG	F1	3404	1/1	0.97	0.10	75,75,75,75	0
48	MG	D1	3509	1/1	0.97	0.09	41,41,41,41	0
48	MG	F1	3510	1/1	0.97	0.10	95,95,95,95	0
48	MG	CQ	202	1/1	0.97	0.06	62,62,62,62	0
48	MG	BW	201	1/1	0.97	0.09	67,67,67,67	0
48	MG	F1	3459	1/1	0.97	0.07	79,79,79,79	0
48	MG	D1	3546	1/1	0.97	0.10	49,49,49,49	0
48	MG	D1	3587	1/1	0.97	0.14	93,93,93,93	0
48	MG	A1	3446	1/1	0.97	0.19	64,64,64,64	0
48	MG	B2	203	1/1	0.97	0.06	81,81,81,81	0
48	MG	D1	3479	1/1	0.97	0.04	50,50,50,50	0
48	MG	C2	203	1/1	0.97	0.06	63,63,63,63	0
48	MG	D1	3630	1/1	0.97	0.14	71,71,71,71	0
48	MG	C2	204	1/1	0.97	0.07	75,75,75,75	0
48	MG	D1	3632	1/1	0.97	0.12	83,83,83,83	0
48	MG	D1	3453	1/1	0.97	0.11	54,54,54,54	0
48	MG	F1	3525	1/1	0.97	0.09	73,73,73,73	0
48	MG	A1	3517	1/1	0.97	0.08	74,74,74,74	0
48	MG	A1	3426	1/1	0.97	0.09	73,73,73,73	0
48	MG	F1	3474	1/1	0.97	0.13	64,64,64,64	0

*Continued on next page...*

*Continued from previous page...*

Mol	Type	Chain	Res	Atoms	RSCC	RSR	B-factors(Å <sup>2</sup> )	Q<0.9
48	MG	D1	3486	1/1	0.97	0.13	47,47,47,47	0
48	MG	D1	3456	1/1	0.97	0.11	70,70,70,70	0
48	MG	D1	3559	1/1	0.97	0.08	55,55,55,55	0
48	MG	D1	3560	1/1	0.97	0.10	64,64,64,64	0
48	MG	A1	3452	1/1	0.97	0.10	90,90,90,90	0
48	MG	E2	204	1/1	0.97	0.06	75,75,75,75	0
48	MG	F1	3426	1/1	0.97	0.24	110,110,110,110	0
48	MG	F1	3427	1/1	0.97	0.16	51,51,51,51	0
48	MG	D1	3490	1/1	0.97	0.16	92,92,92,92	0
48	MG	A1	3456	1/1	0.97	0.12	49,49,49,49	0
48	MG	A1	3495	1/1	0.97	0.06	70,70,70,70	0
48	MG	H1	3437	1/1	0.97	0.11	93,93,93,93	0
48	MG	H1	3493	1/1	0.97	0.12	79,79,79,79	0
48	MG	A1	3597	1/1	0.97	0.38	133,133,133,133	0
48	MG	H1	3439	1/1	0.97	0.12	75,75,75,75	0
48	MG	F1	3432	1/1	0.97	0.08	68,68,68,68	0
48	MG	A1	3598	1/1	0.97	0.21	111,111,111,111	0
48	MG	D1	3462	1/1	0.97	0.19	116,116,116,116	0
48	MG	A1	3457	1/1	0.97	0.35	94,94,94,94	0
48	MG	H1	3444	1/1	0.97	0.06	65,65,65,65	0
48	MG	D1	3570	1/1	0.97	0.20	54,54,54,54	0
48	MG	A1	3432	1/1	0.98	0.07	45,45,45,45	0
48	MG	H1	3421	1/1	0.98	0.13	97,97,97,97	0
48	MG	D1	3428	1/1	0.98	0.06	106,106,106,106	0
48	MG	D1	3405	1/1	0.98	0.10	59,59,59,59	0
48	MG	D1	3569	1/1	0.98	0.09	48,48,48,48	0
48	MG	F1	3528	1/1	0.98	0.06	75,75,75,75	0
48	MG	F1	3460	1/1	0.98	0.14	36,36,36,36	0
48	MG	F1	3505	1/1	0.98	0.10	83,83,83,83	0
48	MG	D1	3469	1/1	0.98	0.10	64,64,64,64	0
48	MG	D1	3430	1/1	0.98	0.08	59,59,59,59	0
48	MG	A1	3410	1/1	0.98	0.21	62,62,62,62	0
48	MG	H1	3458	1/1	0.98	0.06	90,90,90,90	0
48	MG	A1	3543	1/1	0.98	0.08	96,96,96,96	0
48	MG	D1	3556	1/1	0.98	0.07	76,76,76,76	0
48	MG	D1	3489	1/1	0.98	0.07	44,44,44,44	0
48	MG	A1	3440	1/1	0.98	0.04	78,78,78,78	0
48	MG	A1	3561	1/1	0.98	0.14	60,60,60,60	0
48	MG	D1	3411	1/1	0.98	0.11	44,44,44,44	0
48	MG	A1	3421	1/1	0.98	0.06	71,71,71,71	0
48	MG	F1	3450	1/1	0.98	0.09	59,59,59,59	0
48	MG	A1	3476	1/1	0.98	0.07	59,59,59,59	0

*Continued on next page...*

*Continued from previous page...*

Mol	Type	Chain	Res	Atoms	RSCC	RSR	B-factors( $\text{\AA}^2$ )	Q<0.9
48	MG	A1	3524	1/1	0.98	0.12	63,63,63,63	0
48	MG	D1	3480	1/1	0.98	0.09	32,32,32,32	0
48	MG	F1	3454	1/1	0.98	0.15	56,56,56,56	0
48	MG	F1	3546	1/1	0.98	0.07	59,59,59,59	0
49	ZN	AA	101	1/1	0.98	0.14	64,64,64,64	0
48	MG	A1	3525	1/1	0.98	0.08	51,51,51,51	0
49	ZN	AK	201	1/1	0.98	0.10	89,89,89,89	0
49	ZN	BY	201	1/1	0.98	0.10	59,59,59,59	0
49	ZN	DC	201	1/1	0.98	0.07	89,89,89,89	0
49	ZN	DL	201	1/1	0.98	0.17	86,86,86,86	0
49	ZN	EY	201	1/1	0.98	0.10	77,77,77,77	0
49	ZN	FC	201	1/1	0.98	0.04	108,108,108,108	0
48	MG	F1	3499	1/1	0.98	0.04	57,57,57,57	0
49	ZN	GY	201	1/1	0.98	0.10	116,116,116,116	0
49	ZN	HA	101	1/1	0.98	0.14	112,112,112,112	0
48	MG	F1	3523	1/1	0.98	0.09	55,55,55,55	0
49	ZN	HL	201	1/1	0.98	0.08	118,118,118,118	0
48	MG	A1	3489	1/1	0.99	0.07	33,33,33,33	0
48	MG	D1	3533	1/1	0.99	0.07	41,41,41,41	0
48	MG	H1	3497	1/1	0.99	0.13	50,50,50,50	0
48	MG	F1	3467	1/1	0.99	0.10	57,57,57,57	0
48	MG	D1	3554	1/1	0.99	0.12	59,59,59,59	0
49	ZN	AL	201	1/1	0.99	0.09	70,70,70,70	0
48	MG	A1	3502	1/1	0.99	0.10	80,80,80,80	0
49	ZN	CY	202	1/1	0.99	0.08	70,70,70,70	0
49	ZN	DA	103	1/1	0.99	0.14	69,69,69,69	0
48	MG	D1	3410	1/1	0.99	0.12	39,39,39,39	0
49	ZN	DK	202	1/1	0.99	0.11	68,68,68,68	0
48	MG	A1	3413	1/1	0.99	0.18	136,136,136,136	0
48	MG	A1	3534	1/1	0.99	0.13	62,62,62,62	0
49	ZN	FA	103	1/1	0.99	0.12	80,80,80,80	0
48	MG	A1	3460	1/1	0.99	0.13	61,61,61,61	0
49	ZN	FK	202	1/1	0.99	0.12	74,74,74,74	0
48	MG	D1	3502	1/1	0.99	0.07	38,38,38,38	0
48	MG	F1	3435	1/1	0.99	0.11	44,44,44,44	0
48	MG	A1	3473	1/1	0.99	0.08	55,55,55,55	0
48	MG	D1	3471	1/1	0.99	0.20	40,40,40,40	0
49	ZN	HK	201	1/1	0.99	0.11	70,70,70,70	0
48	MG	F1	3438	1/1	0.99	0.14	58,58,58,58	0

## 6.5 Other polymers [i](#)

There are no such residues in this entry.