



wwPDB EM Validation Summary Report ⓘ

Nov 5, 2024 – 01:05 AM JST

PDB ID : 8WO5
EMDB ID : EMD-37679
Title : Cryo-EM structure of the intact flagellar motor-hook complex in the CCW state
Authors : Tan, J.X.; Zhang, L.; Zhou, Y.; Zhu, Y.Q.
Deposited on : 2023-10-06
Resolution : 7.40 Å (reported)
Based on initial models : ?, .

This is a wwPDB EM Validation Summary Report for a publicly released PDB entry.

We welcome your comments at validation@mail.wwpdb.org

A user guide is available at

<https://www.wwpdb.org/validation/2017/EMValidationReportHelp>

with specific help available everywhere you see the ⓘ symbol.

The types of validation reports are described at

<http://www.wwpdb.org/validation/2017/FAQs#types>.

The following versions of software and data (see [references ⓘ](#)) were used in the production of this report:

EMDB validation analysis : 0.0.1.dev113
MolProbity : 4.02b-467
Percentile statistics : 20231227.v01 (using entries in the PDB archive December 27th 2023)
MapQ : 1.9.13
Ideal geometry (proteins) : Engh & Huber (2001)
Ideal geometry (DNA, RNA) : Parkinson et al. (1996)
Validation Pipeline (wwPDB-VP) : 2.39

1 Overall quality at a glance

The following experimental techniques were used to determine the structure:
ELECTRON MICROSCOPY

The reported resolution of this entry is 7.40 Å.

Percentile scores (ranging between 0-100) for global validation metrics of the entry are shown in the following graphic. The table shows the number of entries on which the scores are based.

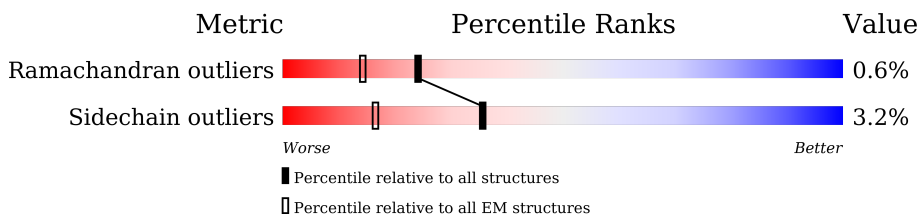

Metric	Whole archive (#Entries)	EM structures (#Entries)
Ramachandran outliers	207382	16835
Sidechain outliers	206894	16415

The table below summarises the geometric issues observed across the polymeric chains and their fit to the map. The red, orange, yellow and green segments of the bar indicate the fraction of residues that contain outliers for ≥ 3 , 2, 1 and 0 types of geometric quality criteria respectively. A grey segment represents the fraction of residues that are not modelled. The numeric value for each fraction is indicated below the corresponding segment, with a dot representing fractions $\leq 5\%$. The upper red bar (where present) indicates the fraction of residues that have poor fit to the EM map (all-atom inclusion $< 40\%$). The numeric value is given above the bar.

Mol	Chain	Length	Quality of chain
1	0	260	
1	1	260	
1	2	260	
1	3	260	
1	4	260	
1	5	260	
1	6	260	
1	7	260	
1	8	260	

Continued on next page...

Continued from previous page...

Mol	Chain	Length	Quality of chain
1	9	260	27% 98%
1	AF	260	15% 95%
1	AG	260	14% 94%
1	AH	260	18% 93%
1	AI	260	21% 92%
1	AJ	260	22% 92%
1	AK	260	16% 91%
1	AL	260	15% 90%
1	AM	260	19% 92%
1	AN	260	23% 92%
1	ZA	260	29% 98%
1	ZB	260	27% 97%
1	ZC	260	19% 98%
1	ZD	260	17% 97%
1	ZE	260	19% 97%
2	A	232	16% 88%
2	B	232	18% 88%
2	C	232	16% 88%
2	D	232	16% 88%
2	E	232	16% 88%
2	F	232	16% 88%
2	G	232	16% 88%
2	H	232	16% 88%
2	I	232	19% 88%
2	J	232	20% 88%

Continued on next page...

Continued from previous page...

Mol	Chain	Length	Quality of chain
2	K	232	21% 88% 9%
2	L	232	22% 88% 9%
2	M	232	25% 88% 9%
2	N	232	28% 88% 9%
2	O	232	28% 88% 9%
2	P	232	27% 88% 9%
2	Q	232	30% 88% 9%
2	R	232	30% 88% 9%
2	S	232	29% 88% 9%
2	T	232	29% 88% 9%
2	U	232	29% 88% 9%
2	V	232	26% 88% 9%
2	W	232	23% 88% 9%
2	X	232	24% 88% 9%
2	Y	232	20% 88% 9%
2	Z	232	19% 88% 9%
3	A0	138	18% 85% 11%
3	A6	138	32% 93% 9%
3	A7	138	22% 86% 12%
3	A8	138	31% 86% 5% 9%
3	A9	138	32% 90% 8%
4	A1	104	12% 84% 12%
4	A2	104	19% 85% 5% 11%
4	A3	104	25% 86% 11%
4	A4	104	21% 86% 11%















Continued on next page...

Continued from previous page...

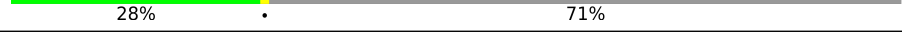
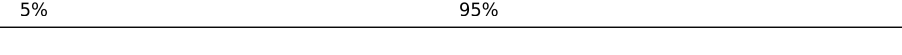
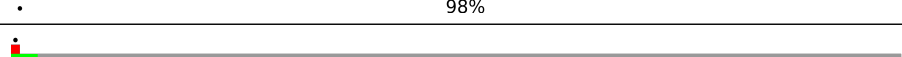
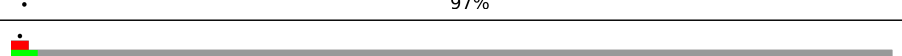
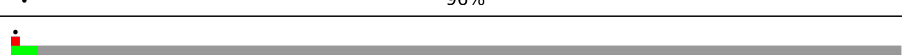
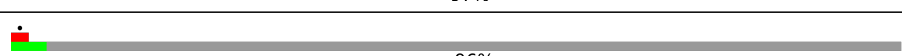
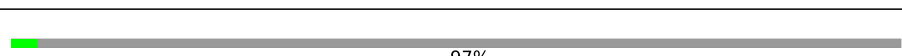
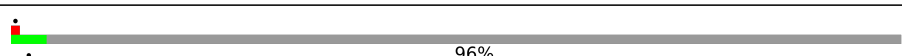
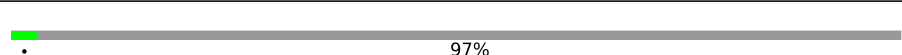
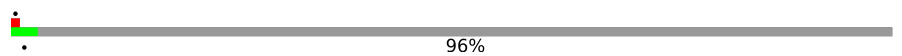
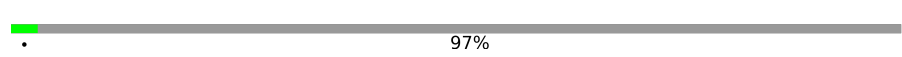
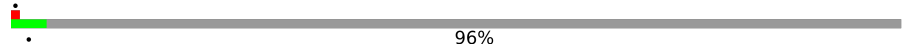
Mol	Chain	Length	Quality of chain
4	A5	104	
4	Az	104	
5	AA	251	
5	AB	251	
5	AC	251	
5	AD	251	
5	AE	251	
6	AO	560	
6	AP	560	
6	AQ	560	
6	AR	560	
6	AS	560	
6	AT	560	
6	AU	560	
6	AV	560	
6	AW	560	
6	AX	560	
6	AY	560	
6	AZ	560	
6	Aa	560	
6	Ac	560	
6	Ad	560	
6	Ae	560	
6	Af	560	
6	Ag	560	









Continued on next page...

Continued from previous page...

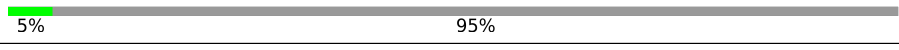
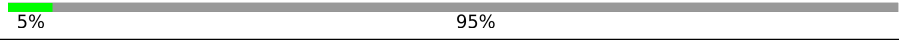
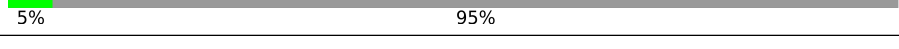
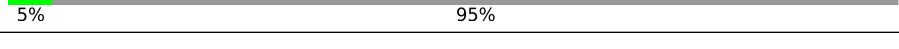
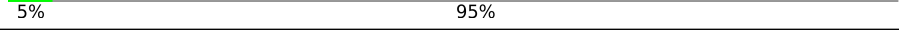
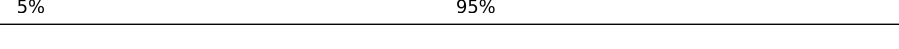
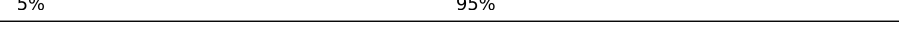
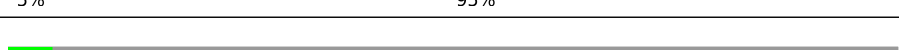
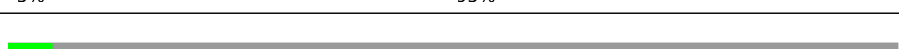
Mol	Chain	Length	Quality of chain
6	Ah	560	 28% 71%
6	Ai	560	 28% 71%
6	Aj	560	 28% 71%
6	Ak	560	 28% 71%
6	Al	560	 28% 71%
6	Am	560	 28% 71%
6	An	560	 28% 71%
6	Ao	560	 28% 71%
6	Ap	560	 28% 71%
6	B6	560	 5% 95%
6	BG	560	 98%
6	BH	560	 97%
6	BI	560	 96%
6	BJ	560	 97%
6	BK	560	 96%
6	BL	560	 97%
6	BM	560	 96%
6	BN	560	 97%
6	BO	560	 96%
6	BP	560	 97%
6	BQ	560	 96%
6	BR	560	 28% 71%
6	BS	560	 28% 71%
6	BT	560	 28% 71%
6	BU	560	 28% 71%

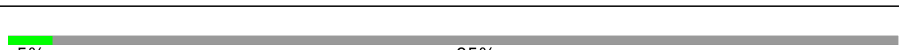
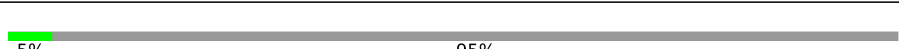
Continued on next page...

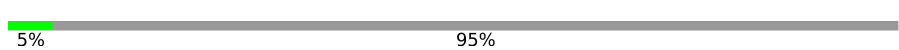
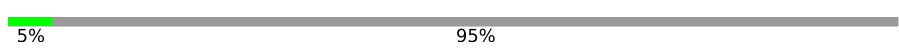
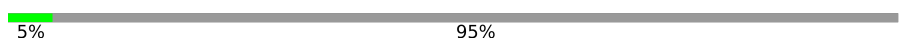
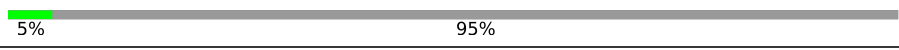
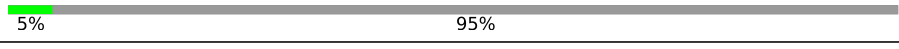
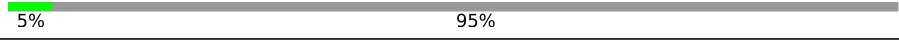
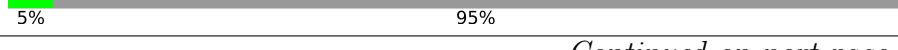
Continued from previous page...

Mol	Chain	Length	Quality of chain
6	BV	560	 28% 71%
6	BW	560	 28% 71%
6	BX	560	 5% 71%
6	Bb	560	 5% 95%
6	Bh	560	 5% 95%
6	Bn	560	 5% 95%
6	Bt	560	 5% 95%
6	Bz	560	 5% 95%
6	C3	560	 5% 95%
6	C7	560	 5% 95%
6	CB	560	 5% 95%
6	CH	560	 5% 95%
6	CN	560	 5% 95%
6	CT	560	 5% 95%
6	CZ	560	 5% 95%
6	Cf	560	 5% 95%
6	Cl	560	 5% 95%
6	Cr	560	 5% 95%
6	Cx	560	 5% 95%
6	D2	560	 5% 95%
6	D8	560	 5% 95%
6	DE	560	 5% 95%
6	DK	560	 5% 95%
6	DR	560	 5% 95%
6	DX	560	 5% 95%

















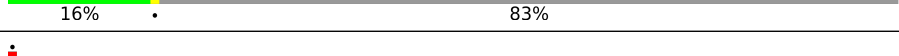
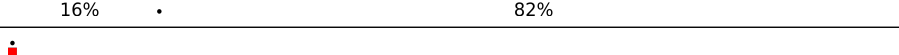
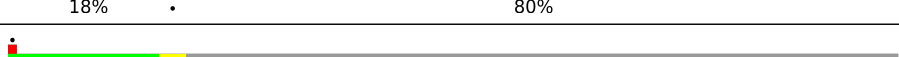
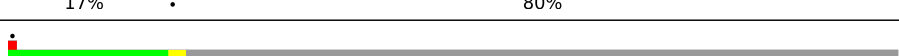

Continued on next page...

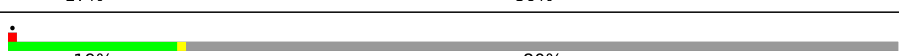
Continued from previous page...

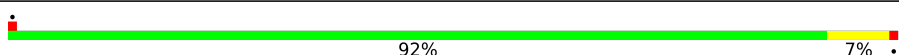
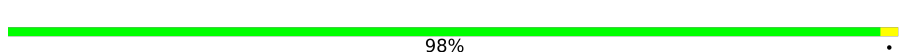
Mol	Chain	Length	Quality of chain
6	Dd	560	5% 95%
6	Dj	560	5% 95%
6	Dp	560	5% 95%
6	Dv	560	5% 95%
6	EF	560	5% 95%
6	EL	560	5% 95%
6	ER	560	5% 95%
6	EX	560	5% 95%
6	Eb	560	5% 95%
6	Eh	560	5% 95%
6	En	560	5% 95%
6	UI	560	8% 25% 72%
6	UJ	560	9% 25% 72%
6	UK	560	8% 25% 72%
6	UL	560	8% 25% 72%
6	UM	560	25% 72%
6	UN	560	25% 72%
6	UO	560	25% 72%
6	UP	560	7% 25% 72%
6	WA	560	18% 80%
6	WB	560	18% 80%
6	WC	560	17% 81%
6	WD	560	18% 80%
6	WE	560	18% 80%
6	WF	560	18% 80%

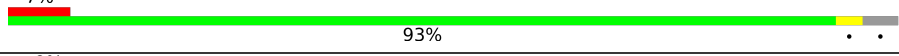
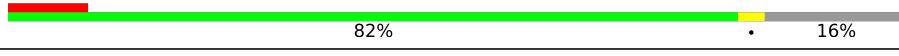
Continued on next page...

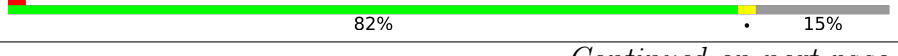
Continued from previous page...

Mol	Chain	Length	Quality of chain
6	WG	560	 18% 80%
6	WH	560	 16% 83%
6	WI	560	 15% 83%
6	WJ	560	 16% 82%
6	WK	560	 16% 82%
6	WL	560	 14% 85%
6	WM	560	 14% 85%
6	WN	560	 14% 85%
6	WO	560	 16% 83%
6	WP	560	 16% 82%
6	WQ	560	 18% 80%
6	WR	560	 17% 80%
6	WS	560	 18% 80%
6	WT	560	 17% 80%
6	WU	560	 19% 80%
6	WV	560	 17% 80%
6	WW	560	 18% 80%
7	Ab	89	 92% 7%
7	Aq	89	 98%
7	Ar	89	 100%
7	As	89	 100%
8	At	264	 7% 93%
9	Au	245	 9% 82% 16%
9	Av	245	 82% 15%
9	Aw	245	 82% 15%

Continued on next page...

Continued from previous page...

Mol	Chain	Length	Quality of chain
9	Ax	245	9% 82% 15%
9	Ay	245	16% 80% 15%
10	BA	134	19% 99%
10	BB	134	16% 96%
10	BC	134	12% 98%
10	BD	134	18% 93% 6%
10	BE	134	14% 94%
10	BF	134	9% 94% 5%
11	ZF	403	48% 97%
11	ZG	403	45% 95%
11	ZH	403	41% 96%
11	ZI	403	38% 97%
11	ZJ	403	31% 97%
11	ZK	403	26% 98%
11	ZL	403	23% 97%
11	ZM	403	19% 97%
11	ZN	403	13% 97%
11	ZO	403	11% 97%
11	ZP	403	11% 95%
11	ZQ	403	11% 97%
11	ZR	403	10% 98%
11	ZS	403	9% 98%
11	ZT	403	6% 97%
11	ZU	403	6% 98%
11	ZV	403	6% 98%

Continued on next page...

Continued from previous page...

Mol	Chain	Length	Quality of chain		
11	ZW	403	7%	96%	
11	ZX	403	7%	99%	
11	ZY	403	9%	98%	
11	ZZ	403	11%	98%	
11	Za	403	15%	98%	
11	Zb	403	18%	98%	
11	Zc	403	22%	97%	
11	Zd	403	24%	98%	
11	Ze	403	28%	97%	
11	Zf	403	32%	98%	
11	Zg	403	35%	98%	
11	Zh	403	37%	98%	
12	a	365	7%	82%	17%
12	b	365	5%	82%	17%
12	c	365	6%	82%	17%
12	d	365	7%	82%	17%
12	e	365	8%	82%	17%
12	f	365	8%	82%	17%
12	g	365	9%	82%	17%
12	h	365	13%	82%	17%
12	i	365	13%	82%	17%
12	j	365	14%	82%	17%
12	k	365	16%	82%	17%
12	l	365	16%	82%	17%
12	m	365	16%	82%	17%





















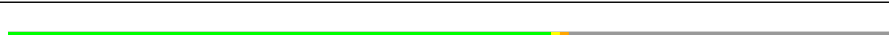

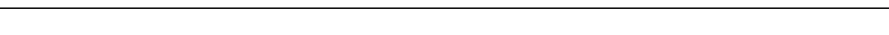
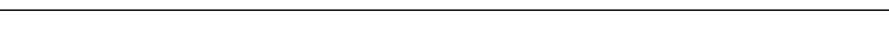
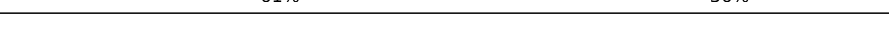
Continued on next page...

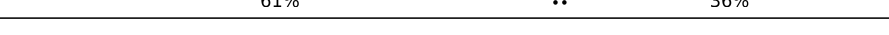
Continued from previous page...

Mol	Chain	Length	Quality of chain		
12	n	365	18%	82%	17%
12	o	365	17%	82%	17%
12	p	365	16%	82%	17%
12	q	365	15%	82%	17%
12	r	365	13%	82%	17%
12	s	365	13%	82%	17%
12	t	365	13%	82%	17%
12	u	365	10%	82%	17%
12	v	365	12%	82%	17%
12	w	365	10%	82%	17%
12	x	365	8%	82%	17%
12	y	365	7%	82%	17%
12	z	365	7%	82%	17%
13	B0	137	61%	..	36%
13	B2	137	61%	..	36%
13	B3	137	61%	..	36%
13	B4	137	61%	..	36%
13	B8	137	61%	..	36%
13	B9	137	61%	..	36%
13	BY	137	61%	..	36%
13	BZ	137	61%	..	36%
13	Bd	137	61%	..	36%
13	Be	137	61%	..	36%
13	Bf	137	61%	..	36%
13	Bj	137	61%	..	36%

Continued on next page...

Continued from previous page...

Mol	Chain	Length	Quality of chain
13	Bk	137	 61% .. 36%
13	Bl	137	 61% .. 36%
13	Bp	137	 61% .. 36%
13	Bq	137	 61% .. 36%
13	Br	137	 61% .. 36%
13	Bv	137	 61% .. 36%
13	Bw	137	 61% .. 36%
13	Bx	137	 61% .. 36%
13	C0	137	 61% .. 36%
13	C1	137	 61% .. 36%
13	C2	137	 61% .. 36%
13	C4	137	 61% .. 36%
13	C5	137	 61% .. 36%
13	C9	137	 61% .. 36%
13	CD	137	 61% .. 36%
13	CE	137	 61% .. 36%
13	CF	137	 61% .. 36%
13	CJ	137	 61% .. 36%
13	CK	137	 61% .. 36%
13	CL	137	 61% .. 36%
13	CP	137	 61% .. 36%
13	CQ	137	 61% .. 36%
13	CR	137	 61% .. 36%
13	CV	137	 61% .. 36%
13	CW	137	 61% .. 36%





















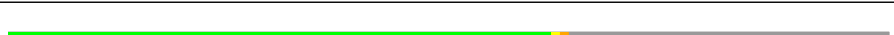

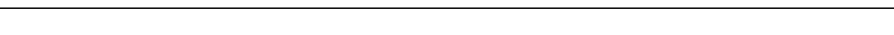
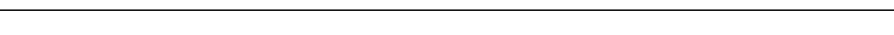
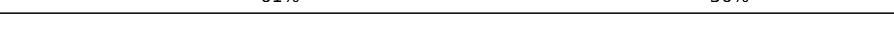
Continued on next page...

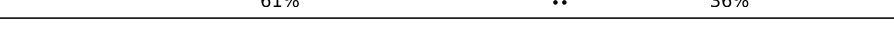
Continued from previous page...

Mol	Chain	Length	Quality of chain	
13	CX	137	61%	36%
13	Cb	137	61%	36%
13	Cc	137	61%	36%
13	Cd	137	61%	36%
13	Ch	137	61%	36%
13	Ci	137	61%	36%
13	Cj	137	61%	36%
13	Cn	137	61%	36%
13	Co	137	61%	36%
13	Cp	137	61%	36%
13	Ct	137	61%	36%
13	Cu	137	61%	36%
13	Cv	137	61%	36%
13	Cz	137	61%	36%
13	D0	137	61%	36%
13	D4	137	61%	36%
13	D5	137	61%	36%
13	D6	137	61%	36%
13	DA	137	61%	36%
13	DC	137	61%	36%
13	DG	137	61%	36%
13	DH	137	61%	36%
13	DI	137	61%	36%
13	DN	137	61%	36%
13	DO	137	61%	36%















Continued on next page...

Continued from previous page...

Mol	Chain	Length	Quality of chain
13	DP	137	
13	DT	137	
13	DU	137	
13	DV	137	
13	DZ	137	
13	Da	137	
13	Db	137	
13	Df	137	
13	Dg	137	
13	Dh	137	
13	Di	137	
13	Dm	137	
13	Dn	137	
13	Dr	137	
13	Ds	137	
13	Dt	137	
13	Dx	137	
13	Dy	137	
13	Dz	137	
13	EA	137	
13	EB	137	
13	EC	137	
13	ED	137	
13	EH	137	
13	EI	137	





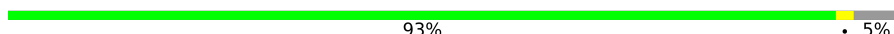
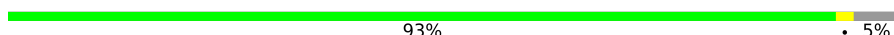
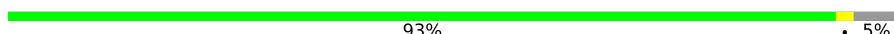
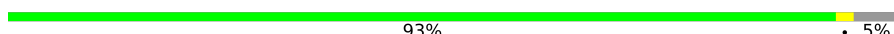
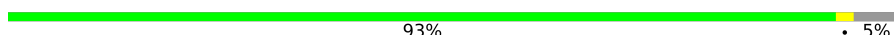
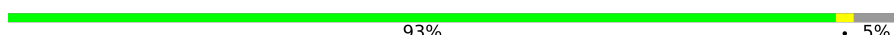
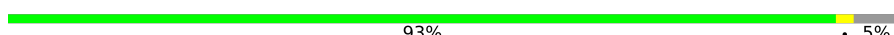
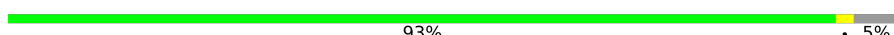
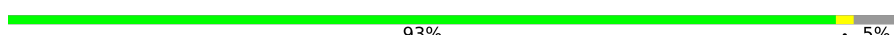
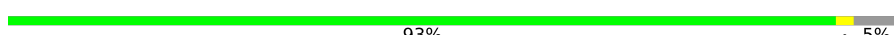



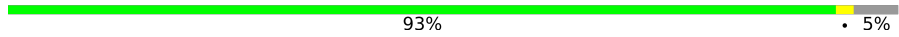
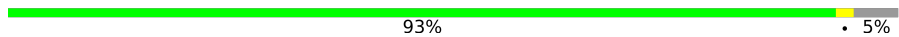

Continued on next page...

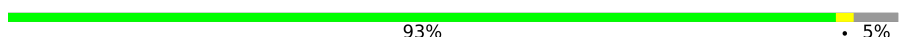
Continued from previous page...

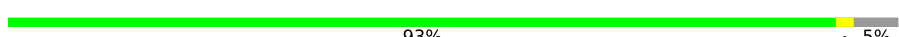
Mol	Chain	Length	Quality of chain
13	EJ	137	 61% .. 36%
13	EN	137	 61% .. 36%
13	EO	137	 61% .. 36%
13	EP	137	 61% .. 36%
13	ET	137	 61% .. 36%
13	EU	137	 61% .. 36%
13	EV	137	 61% .. 36%
13	EZ	137	 61% .. 36%
13	Ed	137	 61% .. 36%
13	Ee	137	 61% .. 36%
13	Ef	137	 61% .. 36%
13	Ej	137	 61% .. 36%
13	Ek	137	 61% .. 36%
13	El	137	 61% .. 36%
13	Ep	137	 61% .. 36%
14	B5	331	 93% . 5%
14	Ba	331	 93% . 5%
14	Bg	331	 93% . 5%
14	Bm	331	 93% . 5%
14	Bs	331	 93% . 5%
14	By	331	 93% . 5%
14	C6	331	 93% . 5%
14	CA	331	 93% . 5%
14	CG	331	 93% . 5%
14	CM	331	 93% . 5%



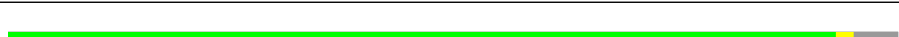

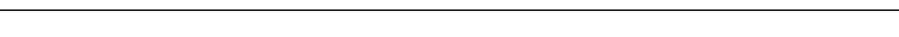
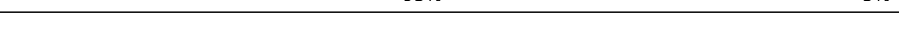
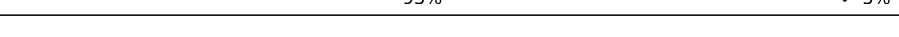
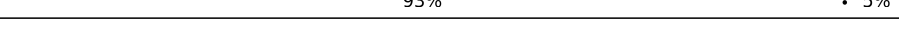
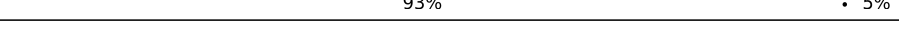
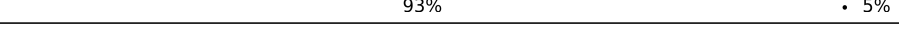
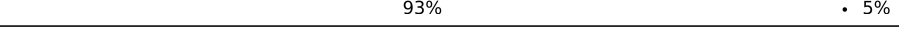
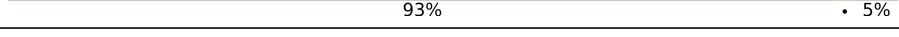
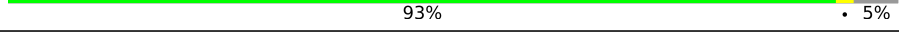
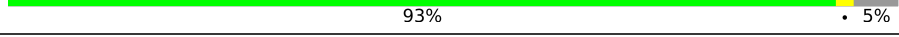
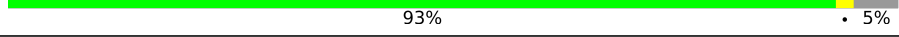
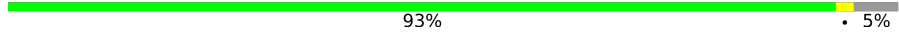



















Continued on next page...

Continued from previous page...

Mol	Chain	Length	Quality of chain
14	CS	331	 93% • 5%
14	CY	331	 93% • 5%
14	Ce	331	 93% • 5%
14	Ck	331	 93% • 5%
14	Cq	331	 93% • 5%
14	Cw	331	 93% • 5%
14	D1	331	 93% • 5%
14	D7	331	 93% • 5%
14	DB	331	 93% • 5%
14	DD	331	 93% • 5%
14	DJ	331	 93% • 5%
14	DQ	331	 93% • 5%
14	DW	331	 93% • 5%
14	Dc	331	 93% • 5%
14	Di	331	 93% • 5%
14	Do	331	 93% • 5%
14	Du	331	 93% • 5%
14	EE	331	 93% • 5%
14	EK	331	 93% • 5%
14	EQ	331	 93% • 5%
14	EW	331	 93% • 5%
14	Ea	331	 93% • 5%
14	Eg	331	 93% • 5%
14	Em	331	 93% • 5%
15	B1	334	 82% • 13%

Continued on next page...

Continued from previous page...

Mol	Chain	Length	Quality of chain
15	B7	334	 82% . 13%
15	Bc	334	 82% . 13%
15	Bi	334	 82% . 13%
15	Bo	334	 82% . 13%
15	Bu	334	 82% . 13%
15	C8	334	 82% . 13%
15	CC	334	 82% . 13%
15	CI	334	 82% . 13%
15	CO	334	 82% . 13%
15	CU	334	 82% . 13%
15	Ca	334	 82% . 13%
15	Cg	334	 82% . 13%
15	Cm	334	 82% . 13%
15	Cs	334	 82% . 13%
15	Cy	334	 82% . 13%
15	D3	334	 82% . 13%
15	D9	334	 82% . 13%
15	DF	334	 82% . 13%
15	DL	334	 82% . 13%
15	DM	334	 82% . 13%
15	DS	334	 82% . 13%
15	DY	334	 82% . 13%
15	De	334	 82% . 13%
15	Dk	334	 82% . 13%
15	Dq	334	 82% . 13%

Continued on next page...

Continued from previous page...

Mol	Chain	Length	Quality of chain
15	Dw	334	 82% • 13%
15	EG	334	 82% • 13%
15	EM	334	 82% • 13%
15	ES	334	 82% • 13%
15	EY	334	 82% • 13%
15	Ec	334	 82% • 13%
15	Ei	334	 82% • 13%
15	Eo	334	 82% • 13%

2 Entry composition [i](#)

There are 15 unique types of molecules in this entry. The entry contains 578432 atoms, of which 0 are hydrogens and 0 are deuteriums.

In the tables below, the AltConf column contains the number of residues with at least one atom in alternate conformation and the Trace column contains the number of residues modelled with at most 2 atoms.

- Molecule 1 is a protein called Flagellar basal-body rod protein FlgG.

Mol	Chain	Residues	Atoms					AltConf	Trace
			Total	C	N	O	S		
1	0	248	Total 1866	C 1154	N 327	O 379	S 6	0	0
1	1	252	Total 1894	C 1172	N 331	O 385	S 6	0	0
1	2	260	Total 1949	C 1202	N 341	O 400	S 6	0	0
1	3	260	Total 1949	C 1202	N 341	O 400	S 6	0	0
1	4	260	Total 1949	C 1202	N 341	O 400	S 6	0	0
1	5	260	Total 1949	C 1202	N 341	O 400	S 6	0	0
1	6	260	Total 1949	C 1202	N 341	O 400	S 6	0	0
1	7	260	Total 1949	C 1202	N 341	O 400	S 6	0	0
1	8	260	Total 1949	C 1202	N 341	O 400	S 6	0	0
1	9	260	Total 1949	C 1202	N 341	O 400	S 6	0	0
1	AF	254	Total 1903	C 1175	N 334	O 389	S 5	0	0
1	AG	255	Total 1911	C 1181	N 335	O 390	S 5	0	0
1	AH	256	Total 1919	C 1186	N 336	O 391	S 6	0	0
1	AI	254	Total 1903	C 1175	N 334	O 389	S 5	0	0
1	AJ	255	Total 1911	C 1181	N 335	O 390	S 5	0	0
1	AK	243	Total 1823	C 1127	N 318	O 373	S 5	0	0
1	AL	248	Total 1866	C 1154	N 327	O 379	S 6	0	0

Continued on next page...

Continued from previous page...

Mol	Chain	Residues	Atoms					AltConf	Trace
1	AM	248	Total	C	N	O	S	0	0
			1866	1154	327	379	6		
1	AN	248	Total	C	N	O	S	0	0
			1866	1154	327	379	6		
1	ZA	260	Total	C	N	O	S	0	0
			1949	1202	341	400	6		
1	ZB	260	Total	C	N	O	S	0	0
			1949	1202	341	400	6		
1	ZC	260	Total	C	N	O	S	0	0
			1949	1202	341	400	6		
1	ZD	260	Total	C	N	O	S	0	0
			1949	1202	341	400	6		
1	ZE	260	Total	C	N	O	S	0	0
			1949	1202	341	400	6		

- Molecule 2 is a protein called Flagellar L-ring protein.

Mol	Chain	Residues	Atoms					AltConf	Trace
2	A	211	Total	C	N	O	S	0	0
			1580	985	282	309	4		
2	B	211	Total	C	N	O	S	0	0
			1580	985	282	309	4		
2	C	211	Total	C	N	O	S	0	0
			1580	985	282	309	4		
2	D	211	Total	C	N	O	S	0	0
			1580	985	282	309	4		
2	E	211	Total	C	N	O	S	0	0
			1580	985	282	309	4		
2	F	211	Total	C	N	O	S	0	0
			1580	985	282	309	4		
2	G	211	Total	C	N	O	S	0	0
			1580	985	282	309	4		
2	H	211	Total	C	N	O	S	0	0
			1580	985	282	309	4		
2	I	211	Total	C	N	O	S	0	0
			1580	985	282	309	4		
2	J	211	Total	C	N	O	S	0	0
			1580	985	282	309	4		
2	K	211	Total	C	N	O	S	0	0
			1580	985	282	309	4		
2	L	211	Total	C	N	O	S	0	0
			1580	985	282	309	4		

Continued on next page...

Continued from previous page...

Mol	Chain	Residues	Atoms					AltConf	Trace
2	M	211	Total	C	N	O	S	0	0
			1580	985	282	309	4		
2	N	211	Total	C	N	O	S	0	0
			1580	985	282	309	4		
2	O	211	Total	C	N	O	S	0	0
			1580	985	282	309	4		
2	P	211	Total	C	N	O	S	0	0
			1580	985	282	309	4		
2	Q	211	Total	C	N	O	S	0	0
			1580	985	282	309	4		
2	R	211	Total	C	N	O	S	0	0
			1580	985	282	309	4		
2	S	211	Total	C	N	O	S	0	0
			1580	985	282	309	4		
2	T	211	Total	C	N	O	S	0	0
			1580	985	282	309	4		
2	U	211	Total	C	N	O	S	0	0
			1580	985	282	309	4		
2	V	211	Total	C	N	O	S	0	0
			1580	985	282	309	4		
2	W	211	Total	C	N	O	S	0	0
			1580	985	282	309	4		
2	X	211	Total	C	N	O	S	0	0
			1580	985	282	309	4		
2	Y	211	Total	C	N	O	S	0	0
			1580	985	282	309	4		
2	Z	211	Total	C	N	O	S	0	0
			1580	985	282	309	4		

- Molecule 3 is a protein called Flagellar basal body rod protein FlgB.

Mol	Chain	Residues	Atoms					AltConf	Trace
3	A0	123	Total	C	N	O	S	0	0
			950	588	172	185	5		
3	A6	134	Total	C	N	O	S	0	0
			1030	633	189	203	5		
3	A7	121	Total	C	N	O	S	0	0
			942	583	172	182	5		
3	A8	125	Total	C	N	O	S	0	0
			967	598	177	187	5		
3	A9	127	Total	C	N	O	S	0	0
			982	606	182	189	5		

- Molecule 4 is a protein called Flagellar hook-basal body complex protein FliE.

Mol	Chain	Residues	Atoms					AltConf	Trace
4	A1	91	Total	C	N	O	S	0	0
			672	415	121	129	7		
4	A2	93	Total	C	N	O	S	0	0
			686	424	123	132	7		
4	A3	93	Total	C	N	O	S	0	0
			686	424	123	132	7		
4	A4	93	Total	C	N	O	S	0	0
			686	424	123	132	7		
4	A5	92	Total	C	N	O	S	0	0
			679	420	122	130	7		
4	Az	59	Total	C	N	O	S	0	0
			429	265	74	83	7		

- Molecule 5 is a protein called Flagellar basal-body rod protein FlgF.

Mol	Chain	Residues	Atoms					AltConf	Trace
5	AA	248	Total	C	N	O	S	0	0
			1804	1106	324	367	7		
5	AB	249	Total	C	N	O	S	0	0
			1812	1111	325	368	8		
5	AC	250	Total	C	N	O	S	0	0
			1820	1116	326	369	9		
5	AD	250	Total	C	N	O	S	0	0
			1820	1116	326	369	9		
5	AE	249	Total	C	N	O	S	0	0
			1812	1111	325	368	8		

- Molecule 6 is a protein called Flagellar M-ring protein.

Mol	Chain	Residues	Atoms					AltConf	Trace
6	AO	164	Total	C	N	O	S	0	0
			1275	776	237	259	3		
6	AP	164	Total	C	N	O	S	0	0
			1275	776	237	259	3		
6	AQ	164	Total	C	N	O	S	0	0
			1275	776	237	259	3		
6	AR	164	Total	C	N	O	S	0	0
			1275	776	237	259	3		
6	AS	164	Total	C	N	O	S	0	0
			1275	776	237	259	3		
6	AT	164	Total	C	N	O	S	0	0
			1275	776	237	259	3		

Continued on next page...

Continued from previous page...

Mol	Chain	Residues	Atoms					AltConf	Trace
			Total	C	N	O	S		
6	AU	164	1275	776	237	259	3	0	0
6	AV	164	1275	776	237	259	3	0	0
6	AW	164	1275	776	237	259	3	0	0
6	AX	164	1275	776	237	259	3	0	0
6	AY	164	1275	776	237	259	3	0	0
6	AZ	164	1275	776	237	259	3	0	0
6	Aa	164	1275	776	237	259	3	0	0
6	Ac	164	1275	776	237	259	3	0	0
6	Ad	164	1275	776	237	259	3	0	0
6	Ae	164	1275	776	237	259	3	0	0
6	Af	164	1275	776	237	259	3	0	0
6	Ag	164	1275	776	237	259	3	0	0
6	Ah	164	1275	776	237	259	3	0	0
6	Ai	164	1275	776	237	259	3	0	0
6	Aj	164	1275	776	237	259	3	0	0
6	Ak	164	1275	776	237	259	3	0	0
6	Al	164	1275	776	237	259	3	0	0
6	Am	164	1275	776	237	259	3	0	0
6	An	164	1275	776	237	259	3	0	0
6	Ao	164	1275	776	237	259	3	0	0
6	Ap	164	1275	776	237	259	3	0	0

Continued on next page...

Continued from previous page...

Mol	Chain	Residues	Atoms				AltConf	Trace	
			Total	C	N	O			
6	BG	13	81	50	15	16	0	0	
6	BH	16	103	64	19	20	0	0	
6	BI	20	133	83	23	27	0	0	
6	BJ	16	103	64	19	20	0	0	
6	BK	21	140	88	24	28	0	0	
6	BL	16	103	64	19	20	0	0	
6	BM	21	140	88	24	28	0	0	
6	BN	16	103	64	19	20	0	0	
6	BO	20	133	83	23	27	0	0	
6	BP	16	103	64	19	20	0	0	
6	BQ	21	140	88	24	28	0	0	
6	BR	164	1275	776	237	259	3	0	0
6	BS	164	1275	776	237	259	3	0	0
6	BT	164	1275	776	237	259	3	0	0
6	BU	164	1275	776	237	259	3	0	0
6	BV	164	1275	776	237	259	3	0	0
6	BW	164	1275	776	237	259	3	0	0
6	BX	164	1275	776	237	259	3	0	0
6	UI	155	1172	733	211	226	2	0	0
6	UJ	155	1172	733	211	226	2	0	0
6	UK	155	1172	733	211	226	2	0	0

Continued on next page...

Continued from previous page...

Mol	Chain	Residues	Atoms					AltConf	Trace
			Total	C	N	O	S		
6	UL	155	1172	733	211	226	2	0	0
6	UM	155	1172	733	211	226	2	0	0
6	UN	155	1172	733	211	226	2	0	0
6	UO	155	1172	733	211	226	2	0	0
6	UP	155	1172	733	211	226	2	0	0
6	WA	113	849	534	148	166	1	0	0
6	WB	111	836	526	146	163	1	0	0
6	WC	108	812	510	142	159	1	0	0
6	WD	110	827	522	144	160	1	0	0
6	WE	112	843	531	147	164	1	0	0
6	WF	111	834	526	145	162	1	0	0
6	WG	112	843	531	147	164	1	0	0
6	WH	95	703	439	126	137	1	0	0
6	WI	95	703	439	126	137	1	0	0
6	WJ	99	737	462	131	143	1	0	0
6	WK	98	729	456	130	142	1	0	0
6	WL	85	622	389	110	122	1	0	0
6	WM	82	596	372	107	116	1	0	0
6	WN	84	611	380	109	121	1	0	0
6	WO	96	714	448	127	138	1	0	0
6	WP	100	741	464	132	144	1	0	0

Continued on next page...

Continued from previous page...

Mol	Chain	Residues	Atoms					AltConf	Trace
			Total	C	N	O	S		
6	WQ	111	834	526	145	162	1	0	0
6	WR	111	834	526	145	162	1	0	0
6	WS	111	834	526	145	162	1	0	0
6	WT	111	834	526	145	162	1	0	0
6	WU	112	843	531	147	164	1	0	0
6	WV	110	827	521	144	161	1	0	0
6	WW	111	834	526	145	162	1	0	0
6	C3	27	224	135	44	42	3	0	0
6	C7	27	224	135	44	42	3	0	0
6	DE	27	224	135	44	42	3	0	0
6	DK	27	224	135	44	42	3	0	0
6	DR	27	224	135	44	42	3	0	0
6	DX	27	224	135	44	42	3	0	0
6	Dd	27	224	135	44	42	3	0	0
6	Dj	27	224	135	44	42	3	0	0
6	Dp	27	224	135	44	42	3	0	0
6	Dv	27	224	135	44	42	3	0	0
6	D2	27	224	135	44	42	3	0	0
6	D8	27	224	135	44	42	3	0	0
6	B6	27	224	135	44	42	3	0	0
6	EF	27	224	135	44	42	3	0	0

Continued on next page...

Continued from previous page...

Mol	Chain	Residues	Atoms					AltConf	Trace
			Total	C	N	O	S		
6	EL	27	Total 224	C 135	N 44	O 42	S 3	0	0
6	ER	27	Total 224	C 135	N 44	O 42	S 3	0	0
6	EX	27	Total 224	C 135	N 44	O 42	S 3	0	0
6	Bb	27	Total 224	C 135	N 44	O 42	S 3	0	0
6	Bh	27	Total 224	C 135	N 44	O 42	S 3	0	0
6	Bn	27	Total 224	C 135	N 44	O 42	S 3	0	0
6	Bt	27	Total 224	C 135	N 44	O 42	S 3	0	0
6	Bz	27	Total 224	C 135	N 44	O 42	S 3	0	0
6	CB	27	Total 224	C 135	N 44	O 42	S 3	0	0
6	CH	27	Total 224	C 135	N 44	O 42	S 3	0	0
6	CN	27	Total 224	C 135	N 44	O 42	S 3	0	0
6	CT	27	Total 224	C 135	N 44	O 42	S 3	0	0
6	CZ	27	Total 224	C 135	N 44	O 42	S 3	0	0
6	Cf	27	Total 224	C 135	N 44	O 42	S 3	0	0
6	Cl	27	Total 224	C 135	N 44	O 42	S 3	0	0
6	Cr	27	Total 224	C 135	N 44	O 42	S 3	0	0
6	Cx	27	Total 224	C 135	N 44	O 42	S 3	0	0
6	Eb	27	Total 224	C 135	N 44	O 42	S 3	0	0
6	Eh	27	Total 224	C 135	N 44	O 42	S 3	0	0
6	En	27	Total 224	C 135	N 44	O 42	S 3	0	0

- Molecule 7 is a protein called Flagellar biosynthetic protein FliQ.

Mol	Chain	Residues	Atoms					AltConf	Trace
7	Ab	89	Total	C	N	O	S	0	0
			670	449	100	114	7		
7	Aq	89	Total	C	N	O	S	0	0
			670	449	100	114	7		
7	Ar	89	Total	C	N	O	S	0	0
			670	449	100	114	7		
7	As	89	Total	C	N	O	S	0	0
			670	449	100	114	7		

- Molecule 8 is a protein called Flagellar biosynthetic protein FliR.

Mol	Chain	Residues	Atoms					AltConf	Trace
8	At	253	Total	C	N	O	S	0	0
			1945	1305	307	318	15		

- Molecule 9 is a protein called Flagellar biosynthetic protein FliP.

Mol	Chain	Residues	Atoms					AltConf	Trace
9	Au	207	Total	C	N	O	S	0	0
			1605	1072	249	272	12		
9	Av	209	Total	C	N	O	S	0	0
			1626	1086	252	276	12		
9	Aw	208	Total	C	N	O	S	0	0
			1614	1077	251	274	12		
9	Ax	208	Total	C	N	O	S	0	0
			1614	1077	251	274	12		
9	Ay	209	Total	C	N	O	S	0	0
			1623	1084	251	276	12		

- Molecule 10 is a protein called Flagellar basal-body rod protein FlgC.

Mol	Chain	Residues	Atoms					AltConf	Trace
10	BA	133	Total	C	N	O	S	0	0
			969	604	167	193	5		
10	BB	132	Total	C	N	O	S	0	0
			964	601	166	192	5		
10	BC	133	Total	C	N	O	S	0	0
			969	604	167	193	5		
10	BD	133	Total	C	N	O	S	0	0
			969	604	167	193	5		
10	BE	131	Total	C	N	O	S	0	0
			956	595	165	191	5		

Continued on next page...

Continued from previous page...

Mol	Chain	Residues	Atoms					AltConf	Trace
			Total	C	N	O	S		
10	BF	133	969	604	167	193	5	0	0

- Molecule 11 is a protein called Flagellar hook protein FlgE.

Mol	Chain	Residues	Atoms					AltConf	Trace
			Total	C	N	O	S		
11	ZF	401	2947	1814	507	618	8	0	0
11	ZG	401	2947	1814	507	618	8	0	0
11	ZH	401	2947	1814	507	618	8	0	0
11	ZI	401	2947	1814	507	618	8	0	0
11	ZJ	401	2947	1814	507	618	8	0	0
11	ZK	401	2947	1814	507	618	8	0	0
11	ZL	401	2947	1814	507	618	8	0	0
11	ZM	401	2947	1814	507	618	8	0	0
11	ZN	401	2947	1814	507	618	8	0	0
11	ZO	401	2947	1814	507	618	8	0	0
11	ZP	401	2947	1814	507	618	8	0	0
11	ZQ	401	2947	1814	507	618	8	0	0
11	ZR	401	2947	1814	507	618	8	0	0
11	ZS	401	2947	1814	507	618	8	0	0
11	ZT	401	2947	1814	507	618	8	0	0
11	ZU	401	2947	1814	507	618	8	0	0
11	ZV	401	2947	1814	507	618	8	0	0
11	ZW	401	2947	1814	507	618	8	0	0

Continued on next page...

Continued from previous page...

Mol	Chain	Residues	Atoms					AltConf	Trace
11	ZX	401	Total 2947	C 1814	N 507	O 618	S 8	0	0
11	ZY	401	Total 2947	C 1814	N 507	O 618	S 8	0	0
11	ZZ	401	Total 2947	C 1814	N 507	O 618	S 8	0	0
11	Za	401	Total 2947	C 1814	N 507	O 618	S 8	0	0
11	Zb	401	Total 2947	C 1814	N 507	O 618	S 8	0	0
11	Zc	401	Total 2947	C 1814	N 507	O 618	S 8	0	0
11	Zd	401	Total 2947	C 1814	N 507	O 618	S 8	0	0
11	Ze	401	Total 2947	C 1814	N 507	O 618	S 8	0	0
11	Zf	401	Total 2947	C 1814	N 507	O 618	S 8	0	0
11	Zg	401	Total 2947	C 1814	N 507	O 618	S 8	0	0
11	Zh	401	Total 2947	C 1814	N 507	O 618	S 8	0	0

- Molecule 12 is a protein called Flagellar P-ring protein.

Mol	Chain	Residues	Atoms					AltConf	Trace
12	a	303	Total 2228	C 1364	N 405	O 446	S 13	0	0
12	b	303	Total 2228	C 1364	N 405	O 446	S 13	0	0
12	c	303	Total 2228	C 1364	N 405	O 446	S 13	0	0
12	d	303	Total 2228	C 1364	N 405	O 446	S 13	0	0
12	e	303	Total 2228	C 1364	N 405	O 446	S 13	0	0
12	f	303	Total 2228	C 1364	N 405	O 446	S 13	0	0
12	g	303	Total 2228	C 1364	N 405	O 446	S 13	0	0
12	h	303	Total 2228	C 1364	N 405	O 446	S 13	0	0

Continued on next page...

Continued from previous page...

Mol	Chain	Residues	Atoms					AltConf	Trace
12	i	303	Total	C	N	O	S	0	0
			2228	1364	405	446	13		
12	j	303	Total	C	N	O	S	0	0
			2228	1364	405	446	13		
12	k	303	Total	C	N	O	S	0	0
			2228	1364	405	446	13		
12	l	303	Total	C	N	O	S	0	0
			2228	1364	405	446	13		
12	m	303	Total	C	N	O	S	0	0
			2228	1364	405	446	13		
12	n	303	Total	C	N	O	S	0	0
			2228	1364	405	446	13		
12	o	303	Total	C	N	O	S	0	0
			2228	1364	405	446	13		
12	p	303	Total	C	N	O	S	0	0
			2228	1364	405	446	13		
12	q	303	Total	C	N	O	S	0	0
			2228	1364	405	446	13		
12	r	303	Total	C	N	O	S	0	0
			2228	1364	405	446	13		
12	s	303	Total	C	N	O	S	0	0
			2228	1364	405	446	13		
12	t	303	Total	C	N	O	S	0	0
			2228	1364	405	446	13		
12	u	303	Total	C	N	O	S	0	0
			2228	1364	405	446	13		
12	v	303	Total	C	N	O	S	0	0
			2228	1364	405	446	13		
12	w	303	Total	C	N	O	S	0	0
			2228	1364	405	446	13		
12	x	303	Total	C	N	O	S	0	0
			2228	1364	405	446	13		
12	y	303	Total	C	N	O	S	0	0
			2228	1364	405	446	13		
12	z	303	Total	C	N	O	S	0	0
			2228	1364	405	446	13		

- Molecule 13 is a protein called Flagellar motor switch protein FliN.

Mol	Chain	Residues	Atoms					AltConf	Trace
13	C4	87	Total	C	N	O	S	0	0
			675	427	118	126	4		

Continued on next page...

Continued from previous page...

Mol	Chain	Residues	Atoms				AltConf	Trace	
13	C5	87	Total 675	C 427	N 118	O 126	S 4	0	0
13	C9	87	Total 675	C 427	N 118	O 126	S 4	0	0
13	C0	87	Total 675	C 427	N 118	O 126	S 4	0	0
13	DA	87	Total 675	C 427	N 118	O 126	S 4	0	0
13	DC	87	Total 675	C 427	N 118	O 126	S 4	0	0
13	DG	87	Total 675	C 427	N 118	O 126	S 4	0	0
13	DH	87	Total 675	C 427	N 118	O 126	S 4	0	0
13	DI	87	Total 675	C 427	N 118	O 126	S 4	0	0
13	DN	87	Total 675	C 427	N 118	O 126	S 4	0	0
13	DO	87	Total 675	C 427	N 118	O 126	S 4	0	0
13	DP	87	Total 675	C 427	N 118	O 126	S 4	0	0
13	DT	87	Total 675	C 427	N 118	O 126	S 4	0	0
13	DU	87	Total 675	C 427	N 118	O 126	S 4	0	0
13	DV	87	Total 675	C 427	N 118	O 126	S 4	0	0
13	DZ	87	Total 675	C 427	N 118	O 126	S 4	0	0
13	Da	87	Total 675	C 427	N 118	O 126	S 4	0	0
13	Db	87	Total 675	C 427	N 118	O 126	S 4	0	0
13	Df	87	Total 675	C 427	N 118	O 126	S 4	0	0
13	Dg	87	Total 675	C 427	N 118	O 126	S 4	0	0
13	Dh	87	Total 675	C 427	N 118	O 126	S 4	0	0
13	Di	87	Total 675	C 427	N 118	O 126	S 4	0	0

Continued on next page...

Continued from previous page...

Mol	Chain	Residues	Atoms					AltConf	Trace
			Total	C	N	O	S		
13	Dm	87	675	427	118	126	4	0	0
13	Dn	87	675	427	118	126	4	0	0
13	Dr	87	675	427	118	126	4	0	0
13	Ds	87	675	427	118	126	4	0	0
13	Dt	87	675	427	118	126	4	0	0
13	Dx	87	675	427	118	126	4	0	0
13	Dy	87	675	427	118	126	4	0	0
13	Dz	87	675	427	118	126	4	0	0
13	D4	87	675	427	118	126	4	0	0
13	D5	87	675	427	118	126	4	0	0
13	D6	87	675	427	118	126	4	0	0
13	D0	87	675	427	118	126	4	0	0
13	EA	87	675	427	118	126	4	0	0
13	EB	87	675	427	118	126	4	0	0
13	B0	87	675	427	118	126	4	0	0
13	B2	87	675	427	118	126	4	0	0
13	B3	87	675	427	118	126	4	0	0
13	B4	87	675	427	118	126	4	0	0
13	B8	87	675	427	118	126	4	0	0
13	B9	87	675	427	118	126	4	0	0
13	EC	87	675	427	118	126	4	0	0

Continued on next page...

Continued from previous page...

Mol	Chain	Residues	Atoms				AltConf	Trace	
			Total	C	N	O	S		
13	ED	87	675	427	118	126	4	0	0
13	EH	87	675	427	118	126	4	0	0
13	EI	87	675	427	118	126	4	0	0
13	EJ	87	675	427	118	126	4	0	0
13	EN	87	675	427	118	126	4	0	0
13	EO	87	675	427	118	126	4	0	0
13	EP	87	675	427	118	126	4	0	0
13	ET	87	675	427	118	126	4	0	0
13	EU	87	675	427	118	126	4	0	0
13	EV	87	675	427	118	126	4	0	0
13	EZ	87	675	427	118	126	4	0	0
13	BY	87	675	427	118	126	4	0	0
13	BZ	87	675	427	118	126	4	0	0
13	Bd	87	675	427	118	126	4	0	0
13	Be	87	675	427	118	126	4	0	0
13	Bf	87	675	427	118	126	4	0	0
13	Bj	87	675	427	118	126	4	0	0
13	Bk	87	675	427	118	126	4	0	0
13	Bl	87	675	427	118	126	4	0	0
13	Bp	87	675	427	118	126	4	0	0
13	Bq	87	675	427	118	126	4	0	0

Continued on next page...

Continued from previous page...

Mol	Chain	Residues	Atoms					AltConf	Trace
			Total	C	N	O	S		
13	Br	87	Total 675	C 427	N 118	O 126	S 4	0	0
13	Bv	87	Total 675	C 427	N 118	O 126	S 4	0	0
13	Bw	87	Total 675	C 427	N 118	O 126	S 4	0	0
13	Bx	87	Total 675	C 427	N 118	O 126	S 4	0	0
13	C1	87	Total 675	C 427	N 118	O 126	S 4	0	0
13	C2	87	Total 675	C 427	N 118	O 126	S 4	0	0
13	CD	87	Total 675	C 427	N 118	O 126	S 4	0	0
13	CE	87	Total 675	C 427	N 118	O 126	S 4	0	0
13	CF	87	Total 675	C 427	N 118	O 126	S 4	0	0
13	CJ	87	Total 675	C 427	N 118	O 126	S 4	0	0
13	CK	87	Total 675	C 427	N 118	O 126	S 4	0	0
13	CL	87	Total 675	C 427	N 118	O 126	S 4	0	0
13	CP	87	Total 675	C 427	N 118	O 126	S 4	0	0
13	CQ	87	Total 675	C 427	N 118	O 126	S 4	0	0
13	CR	87	Total 675	C 427	N 118	O 126	S 4	0	0
13	CV	87	Total 675	C 427	N 118	O 126	S 4	0	0
13	CW	87	Total 675	C 427	N 118	O 126	S 4	0	0
13	CX	87	Total 675	C 427	N 118	O 126	S 4	0	0
13	Cb	87	Total 675	C 427	N 118	O 126	S 4	0	0
13	Cc	87	Total 675	C 427	N 118	O 126	S 4	0	0
13	Cd	87	Total 675	C 427	N 118	O 126	S 4	0	0

Continued on next page...

Continued from previous page...

Mol	Chain	Residues	Atoms					AltConf	Trace
13	Ch	87	Total 675	C 427	N 118	O 126	S 4	0	0
13	Ci	87	Total 675	C 427	N 118	O 126	S 4	0	0
13	Cj	87	Total 675	C 427	N 118	O 126	S 4	0	0
13	Cn	87	Total 675	C 427	N 118	O 126	S 4	0	0
13	Co	87	Total 675	C 427	N 118	O 126	S 4	0	0
13	Cp	87	Total 675	C 427	N 118	O 126	S 4	0	0
13	Ct	87	Total 675	C 427	N 118	O 126	S 4	0	0
13	Cu	87	Total 675	C 427	N 118	O 126	S 4	0	0
13	Cv	87	Total 675	C 427	N 118	O 126	S 4	0	0
13	Cz	87	Total 675	C 427	N 118	O 126	S 4	0	0
13	Ed	87	Total 675	C 427	N 118	O 126	S 4	0	0
13	Ee	87	Total 675	C 427	N 118	O 126	S 4	0	0
13	Ef	87	Total 675	C 427	N 118	O 126	S 4	0	0
13	Ej	87	Total 675	C 427	N 118	O 126	S 4	0	0
13	Ek	87	Total 675	C 427	N 118	O 126	S 4	0	0
13	El	87	Total 675	C 427	N 118	O 126	S 4	0	0
13	Ep	87	Total 675	C 427	N 118	O 126	S 4	0	0

- Molecule 14 is a protein called Flagellar motor switch protein FliG.

Mol	Chain	Residues	Atoms					AltConf	Trace
14	C6	315	Total 2462	C 1535	N 435	O 483	S 9	0	0
14	DB	315	Total 2462	C 1535	N 435	O 483	S 9	0	0

Continued on next page...

Continued from previous page...

Mol	Chain	Residues	Atoms					AltConf	Trace
14	DD	315	Total 2462	C 1535	N 435	O 483	S 9	0	0
14	DJ	315	Total 2462	C 1535	N 435	O 483	S 9	0	0
14	DQ	315	Total 2462	C 1535	N 435	O 483	S 9	0	0
14	DW	315	Total 2462	C 1535	N 435	O 483	S 9	0	0
14	Dc	315	Total 2462	C 1535	N 435	O 483	S 9	0	0
14	Di	315	Total 2462	C 1535	N 435	O 483	S 9	0	0
14	Do	315	Total 2462	C 1535	N 435	O 483	S 9	0	0
14	Du	315	Total 2462	C 1535	N 435	O 483	S 9	0	0
14	D1	315	Total 2462	C 1535	N 435	O 483	S 9	0	0
14	D7	315	Total 2462	C 1535	N 435	O 483	S 9	0	0
14	B5	315	Total 2462	C 1535	N 435	O 483	S 9	0	0
14	EE	315	Total 2462	C 1535	N 435	O 483	S 9	0	0
14	EK	315	Total 2462	C 1535	N 435	O 483	S 9	0	0
14	EQ	315	Total 2462	C 1535	N 435	O 483	S 9	0	0
14	EW	315	Total 2462	C 1535	N 435	O 483	S 9	0	0
14	Ba	315	Total 2462	C 1535	N 435	O 483	S 9	0	0
14	Bg	315	Total 2462	C 1535	N 435	O 483	S 9	0	0
14	Bm	315	Total 2462	C 1535	N 435	O 483	S 9	0	0
14	Bs	315	Total 2462	C 1535	N 435	O 483	S 9	0	0
14	By	315	Total 2462	C 1535	N 435	O 483	S 9	0	0
14	CA	315	Total 2462	C 1535	N 435	O 483	S 9	0	0

Continued on next page...

Continued from previous page...

Mol	Chain	Residues	Atoms					AltConf	Trace
14	CG	315	Total	C	N	O	S	0	0
			2462	1535	435	483	9		
14	CM	315	Total	C	N	O	S	0	0
			2462	1535	435	483	9		
14	CS	315	Total	C	N	O	S	0	0
			2462	1535	435	483	9		
14	CY	315	Total	C	N	O	S	0	0
			2462	1535	435	483	9		
14	Ce	315	Total	C	N	O	S	0	0
			2462	1535	435	483	9		
14	Ck	315	Total	C	N	O	S	0	0
			2462	1535	435	483	9		
14	Cq	315	Total	C	N	O	S	0	0
			2462	1535	435	483	9		
14	Cw	315	Total	C	N	O	S	0	0
			2462	1535	435	483	9		
14	Ea	315	Total	C	N	O	S	0	0
			2462	1535	435	483	9		
14	Eg	315	Total	C	N	O	S	0	0
			2462	1535	435	483	9		
14	Em	315	Total	C	N	O	S	0	0
			2462	1535	435	483	9		

- Molecule 15 is a protein called Flagellar motor switch protein FlIM.

Mol	Chain	Residues	Atoms					AltConf	Trace
15	C8	289	Total	C	N	O	S	0	0
			2341	1492	423	421	5		
15	DF	289	Total	C	N	O	S	0	0
			2341	1492	423	421	5		
15	DL	289	Total	C	N	O	S	0	0
			2341	1492	423	421	5		
15	DM	289	Total	C	N	O	S	0	0
			2341	1492	423	421	5		
15	DS	289	Total	C	N	O	S	0	0
			2341	1492	423	421	5		
15	DY	289	Total	C	N	O	S	0	0
			2341	1492	423	421	5		
15	De	289	Total	C	N	O	S	0	0
			2341	1492	423	421	5		
15	Dk	289	Total	C	N	O	S	0	0
			2341	1492	423	421	5		

Continued on next page...

Continued from previous page...

Mol	Chain	Residues	Atoms					AltConf	Trace
			Total	C	N	O	S		
15	Dq	289	Total 2341	C 1492	N 423	O 421	S 5	0	0
15	Dw	289	Total 2341	C 1492	N 423	O 421	S 5	0	0
15	D3	289	Total 2341	C 1492	N 423	O 421	S 5	0	0
15	D9	289	Total 2341	C 1492	N 423	O 421	S 5	0	0
15	B1	289	Total 2341	C 1492	N 423	O 421	S 5	0	0
15	B7	289	Total 2341	C 1492	N 423	O 421	S 5	0	0
15	EG	289	Total 2341	C 1492	N 423	O 421	S 5	0	0
15	EM	289	Total 2341	C 1492	N 423	O 421	S 5	0	0
15	ES	289	Total 2341	C 1492	N 423	O 421	S 5	0	0
15	EY	289	Total 2341	C 1492	N 423	O 421	S 5	0	0
15	Bc	289	Total 2341	C 1492	N 423	O 421	S 5	0	0
15	Bi	289	Total 2341	C 1492	N 423	O 421	S 5	0	0
15	Bo	289	Total 2341	C 1492	N 423	O 421	S 5	0	0
15	Bu	289	Total 2341	C 1492	N 423	O 421	S 5	0	0
15	CC	289	Total 2341	C 1492	N 423	O 421	S 5	0	0
15	CI	289	Total 2341	C 1492	N 423	O 421	S 5	0	0
15	CO	289	Total 2341	C 1492	N 423	O 421	S 5	0	0
15	CU	289	Total 2341	C 1492	N 423	O 421	S 5	0	0
15	Ca	289	Total 2341	C 1492	N 423	O 421	S 5	0	0
15	Cg	289	Total 2341	C 1492	N 423	O 421	S 5	0	0
15	Cm	289	Total 2341	C 1492	N 423	O 421	S 5	0	0

Continued on next page...

Continued from previous page...

Mol	Chain	Residues	Atoms					AltConf	Trace
			Total	C	N	O	S		
15	Cs	289	Total 2341	C 1492	N 423	O 421	S 5	0	0
15	Cy	289	Total 2341	C 1492	N 423	O 421	S 5	0	0
15	Ec	289	Total 2341	C 1492	N 423	O 421	S 5	0	0
15	Ei	289	Total 2341	C 1492	N 423	O 421	S 5	0	0
15	Eo	289	Total 2341	C 1492	N 423	O 421	S 5	0	0

3 Residue-property plots

These plots are drawn for all protein, RNA, DNA and oligosaccharide chains in the entry. The first graphic for a chain summarises the proportions of the various outlier classes displayed in the second graphic. The second graphic shows the sequence view annotated by issues in geometry and atom inclusion in map density. Residues are color-coded according to the number of geometric quality criteria for which they contain at least one outlier: green = 0, yellow = 1, orange = 2 and red = 3 or more. A red diamond above a residue indicates a poor fit to the EM map for this residue (all-atom inclusion < 40%). Stretches of 2 or more consecutive residues without any outlier are shown as a green connector. Residues present in the sample, but not in the model, are shown in grey.

- Molecule 1: Flagellar basal-body rod protein FlgG

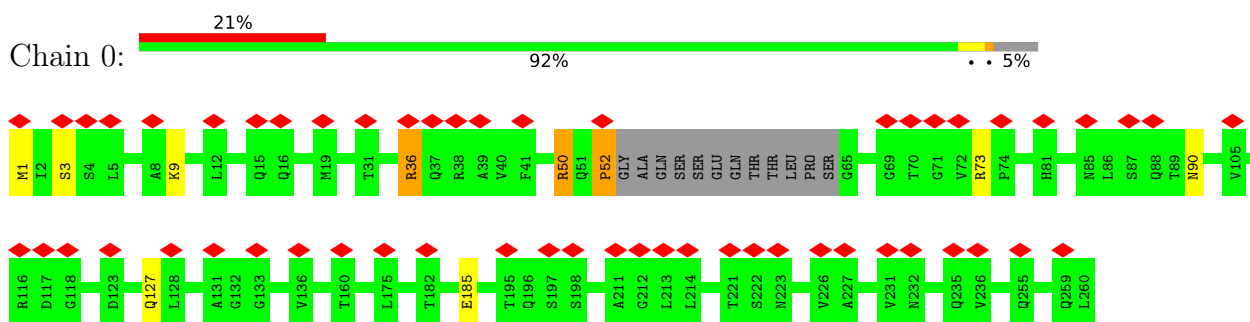

- Molecule 1: Flagellar basal-body rod protein FlgG

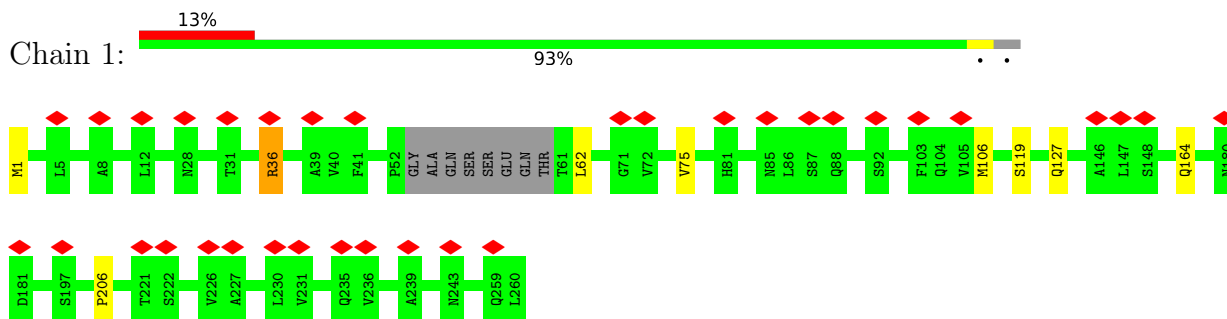

- Molecule 1: Flagellar basal-body rod protein FlgG

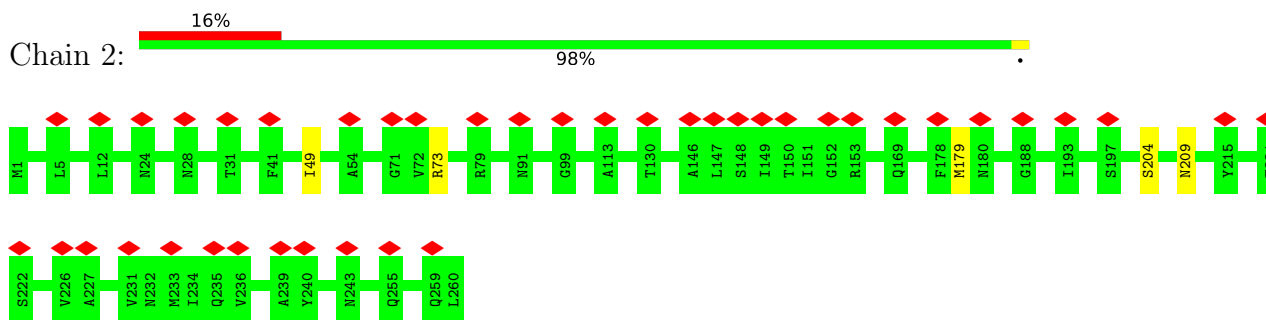

- Molecule 1: Flagellar basal-body rod protein FlgG



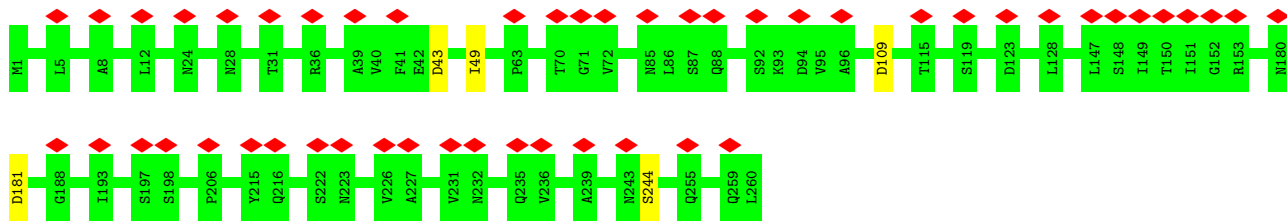

• Molecule 1: Flagellar basal-body rod protein FlgG

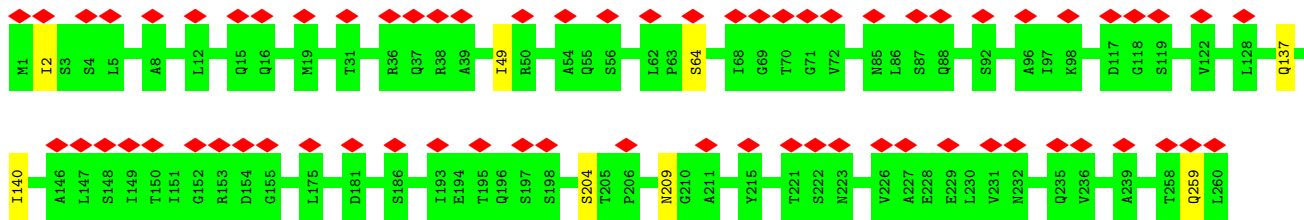

• Molecule 1: Flagellar basal-body rod protein FlgG

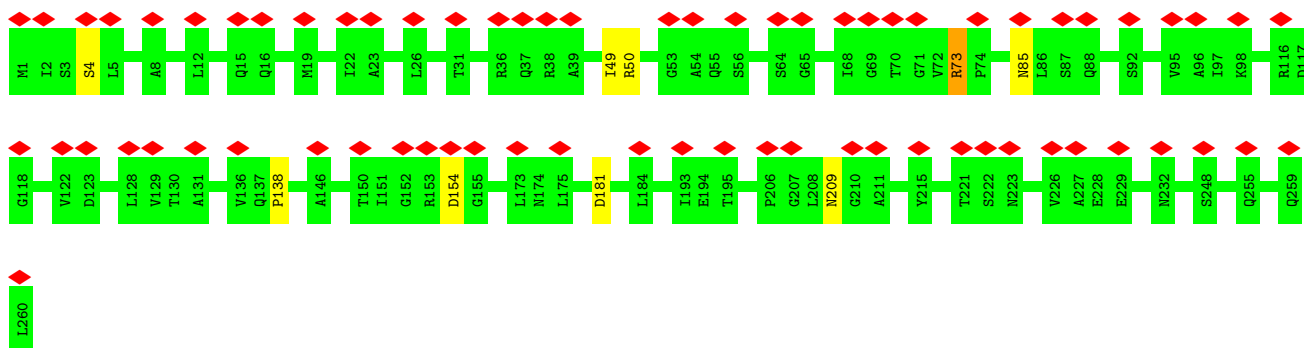

• Molecule 1: Flagellar basal-body rod protein FlgG

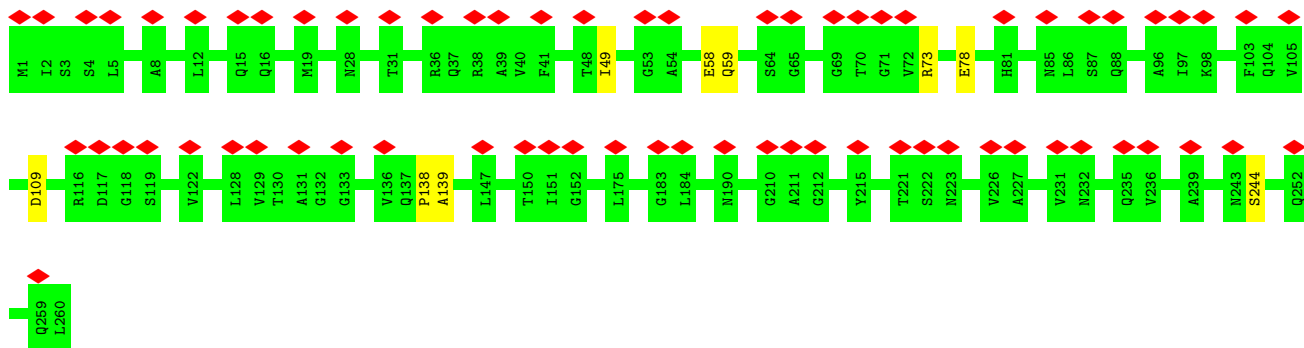

• Molecule 1: Flagellar basal-body rod protein FlgG

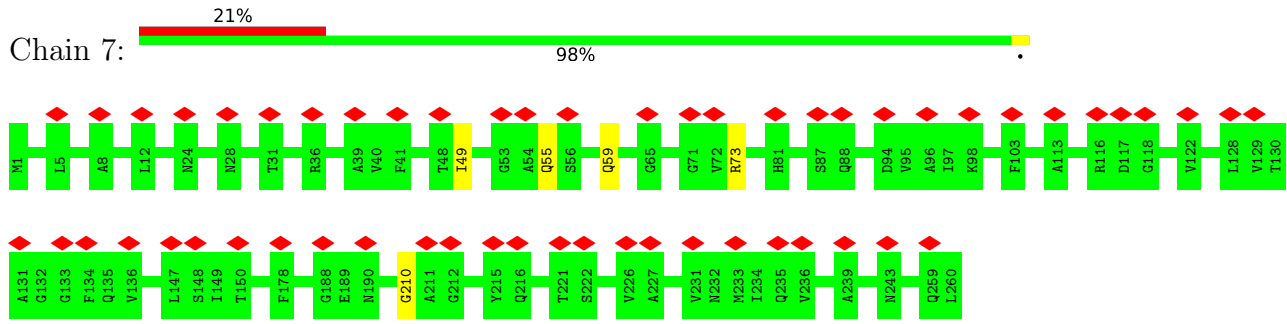

• Molecule 1: Flagellar basal-body rod protein FlgG

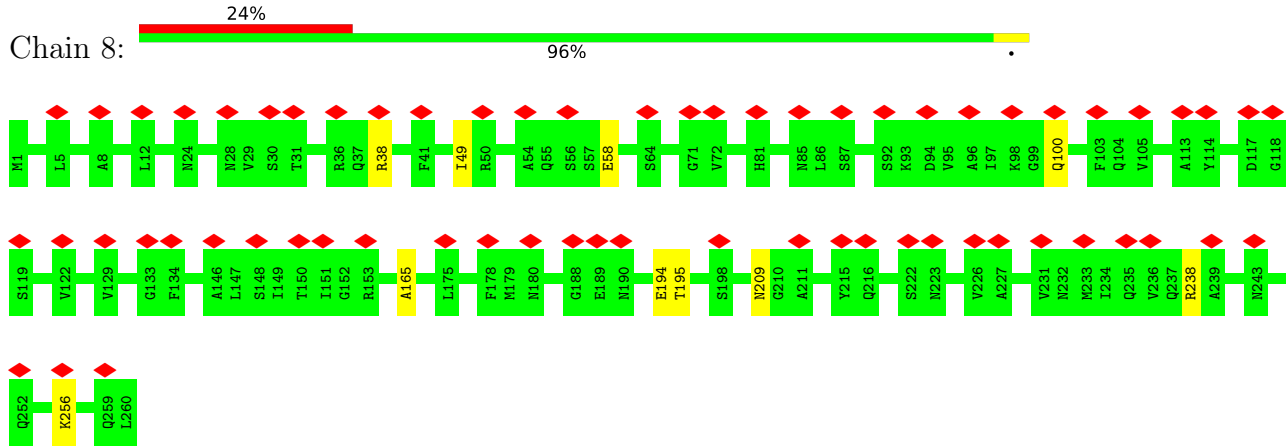

• Molecule 1: Flagellar basal-body rod protein FlgG

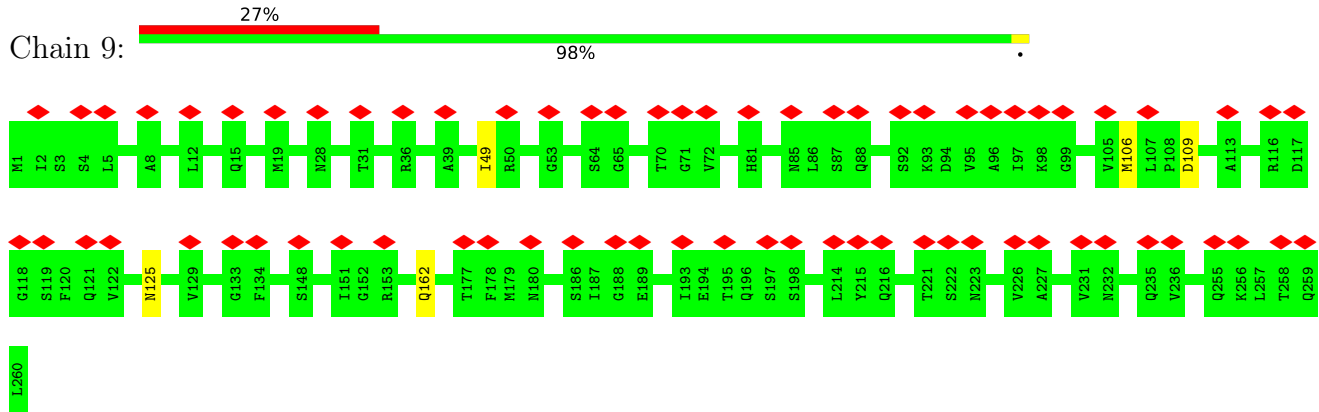

• Molecule 1: Flagellar basal-body rod protein FlgG

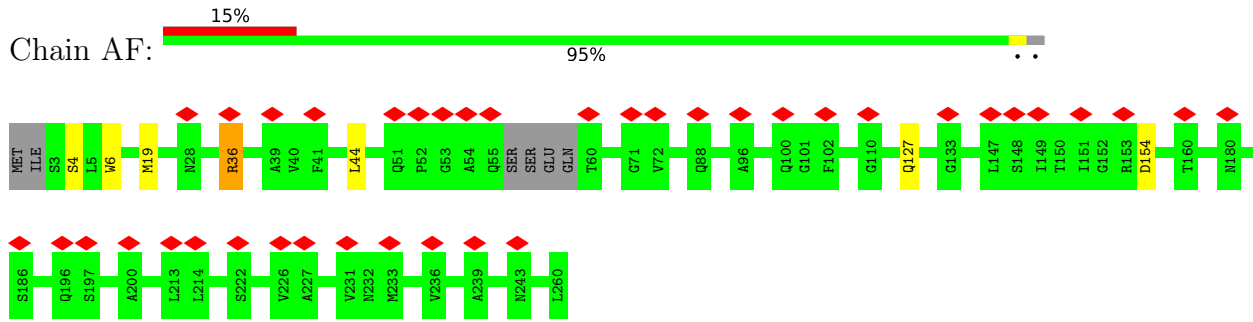

• Molecule 1: Flagellar basal-body rod protein FlgG

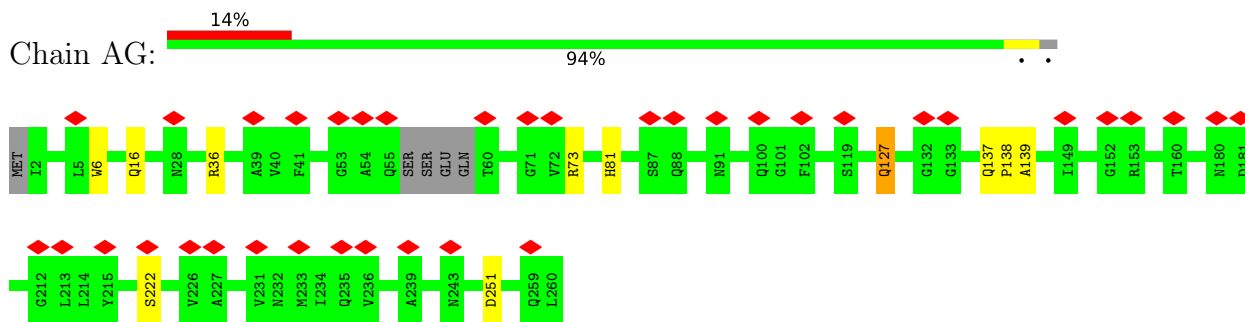

• Molecule 1: Flagellar basal-body rod protein FlgG

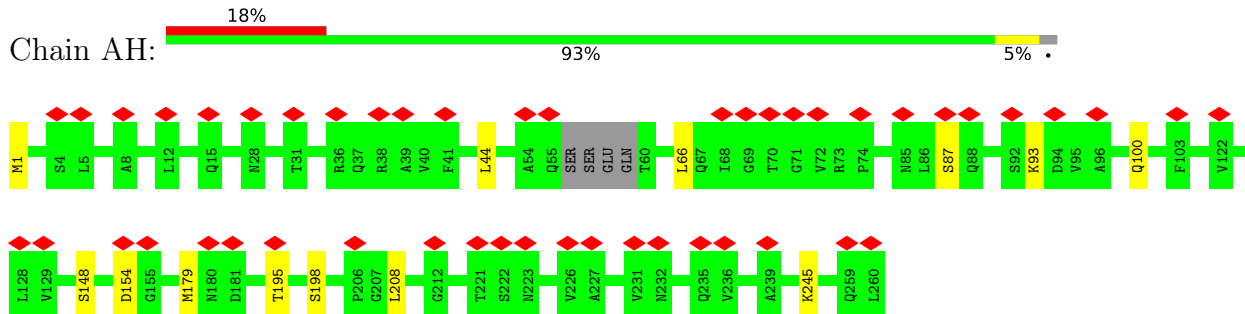

• Molecule 1: Flagellar basal-body rod protein FlgG

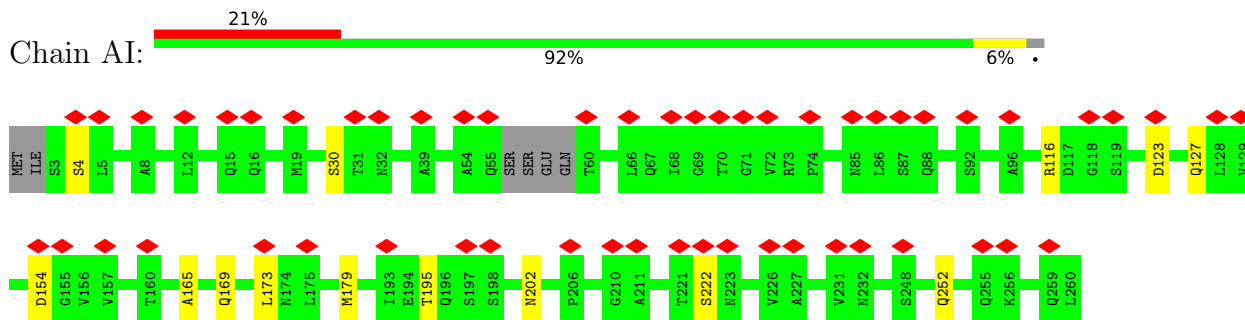

• Molecule 1: Flagellar basal-body rod protein FlgG

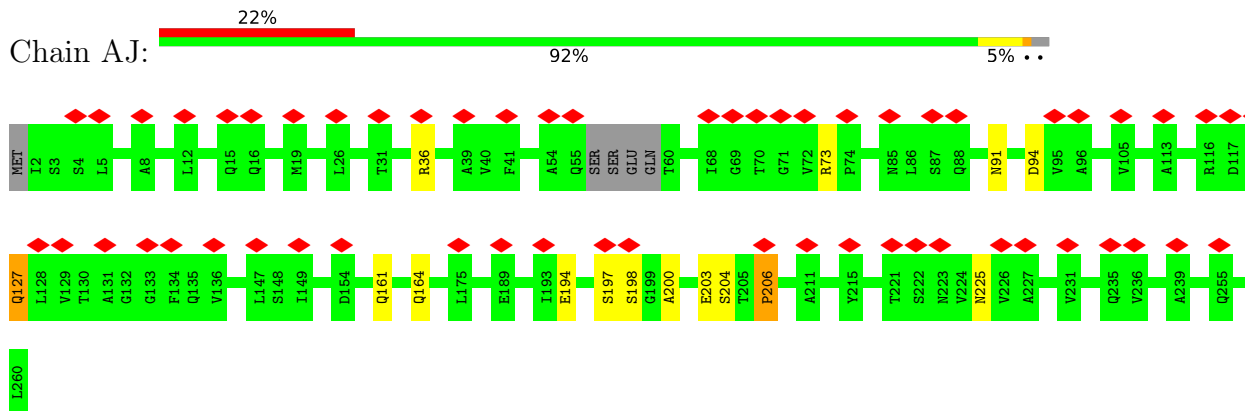

• Molecule 1: Flagellar basal-body rod protein FlgG



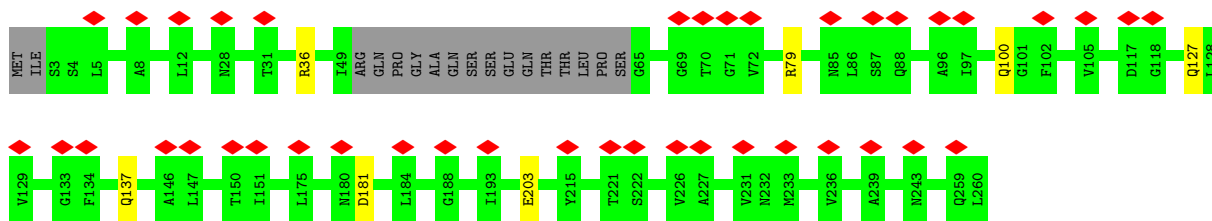

• Molecule 1: Flagellar basal-body rod protein FlgG

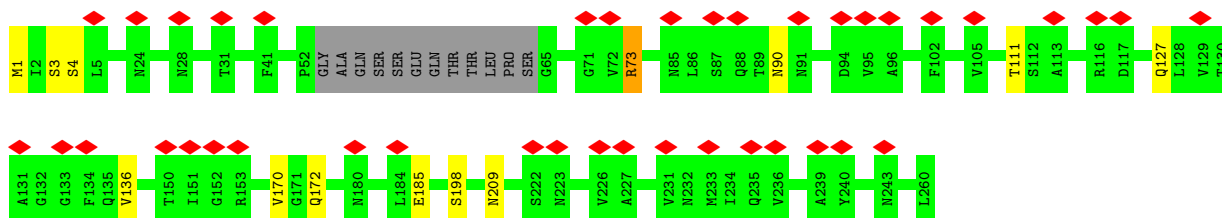
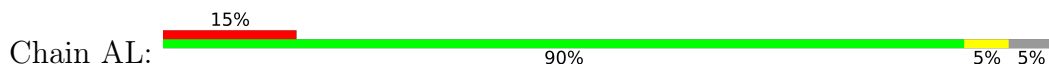

• Molecule 1: Flagellar basal-body rod protein FlgG

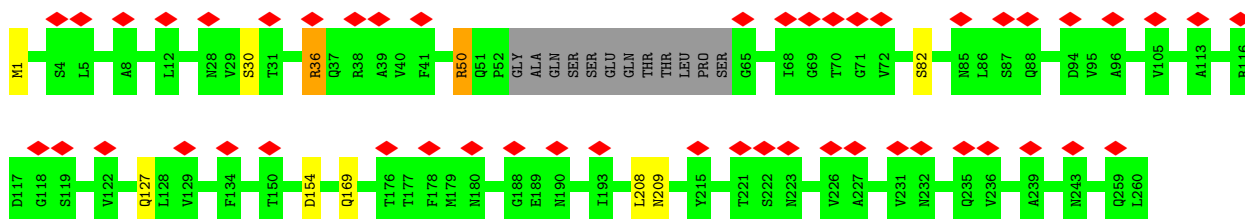

• Molecule 1: Flagellar basal-body rod protein FlgG

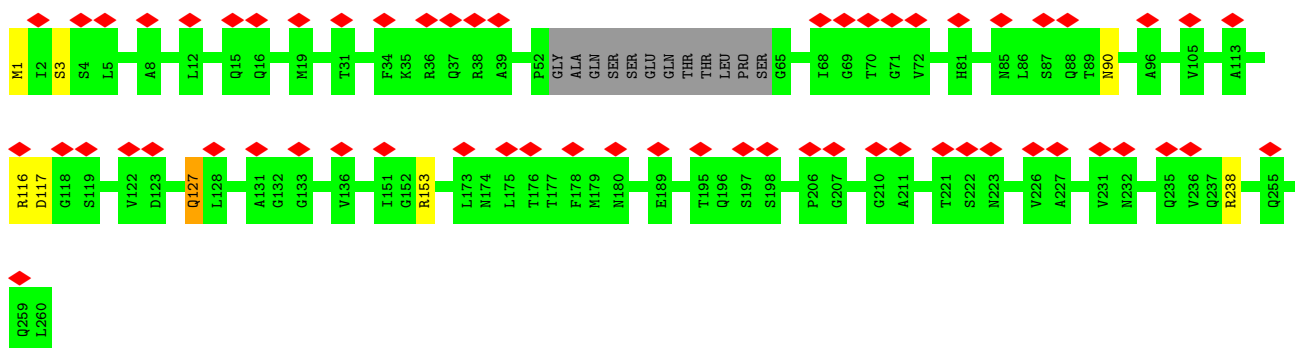
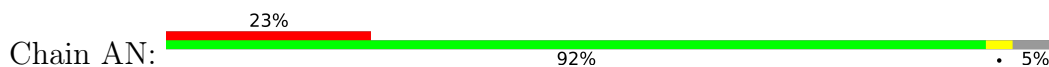

• Molecule 1: Flagellar basal-body rod protein FlgG



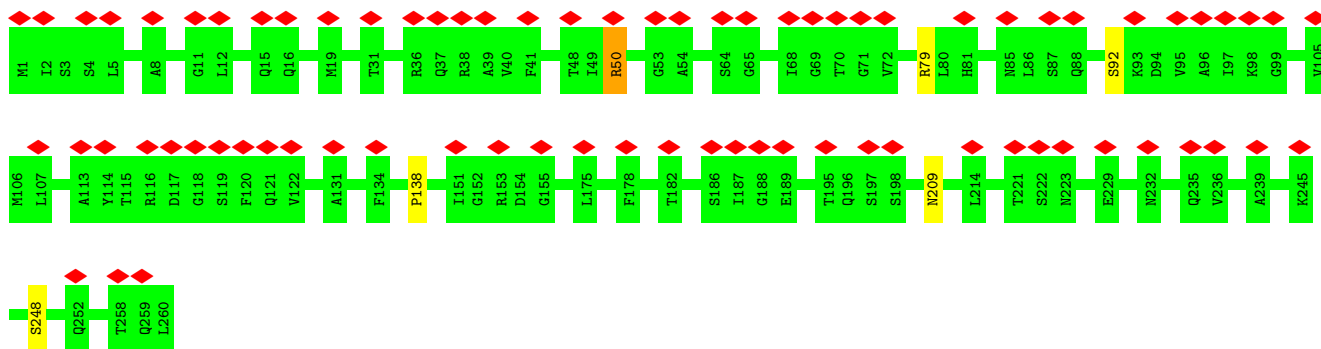

• Molecule 1: Flagellar basal-body rod protein FlgG

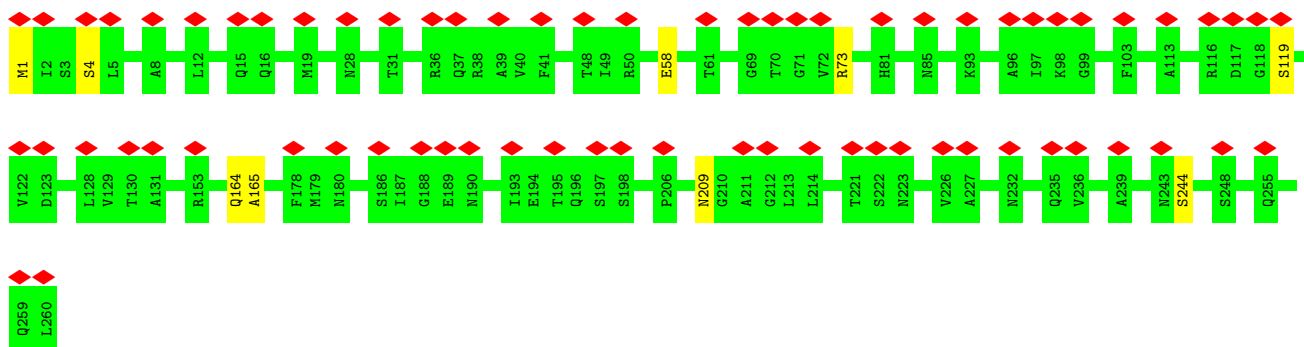

• Molecule 1: Flagellar basal-body rod protein FlgG

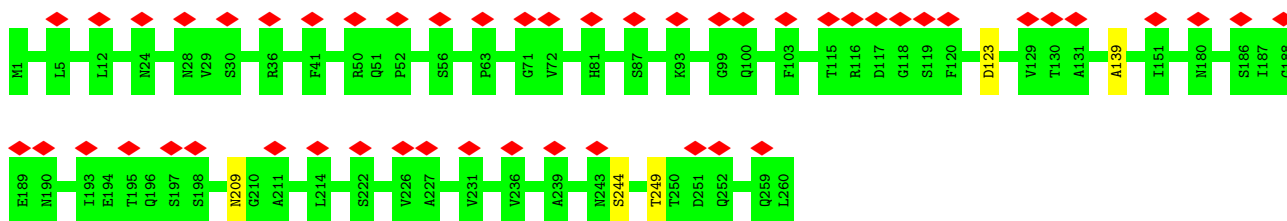

• Molecule 1: Flagellar basal-body rod protein FlgG

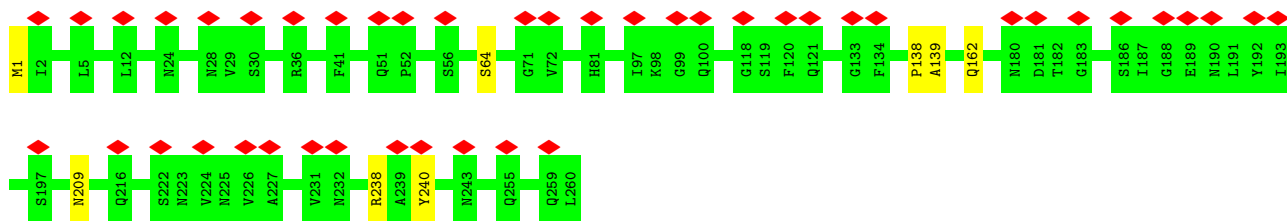

• Molecule 1: Flagellar basal-body rod protein FlgG

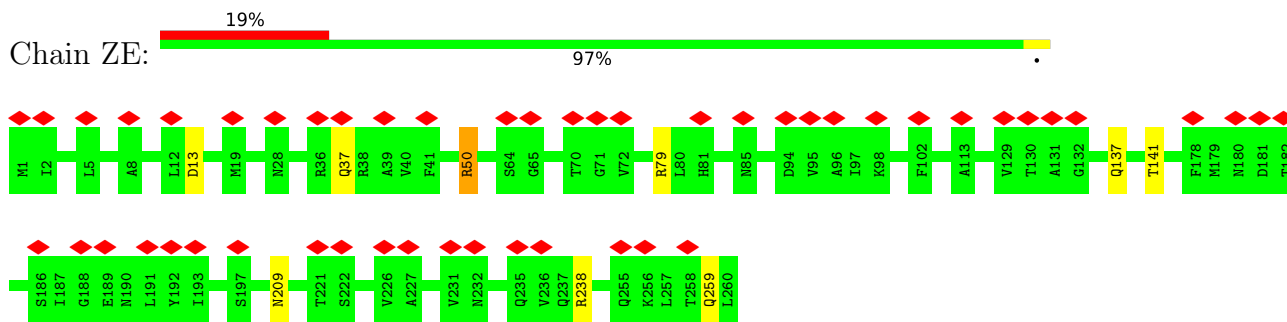

• Molecule 2: Flagellar L-ring protein

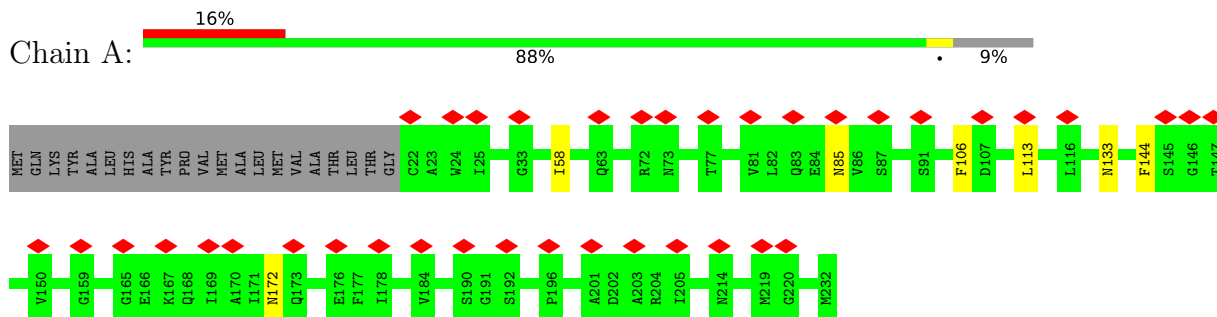

• Molecule 2: Flagellar L-ring protein

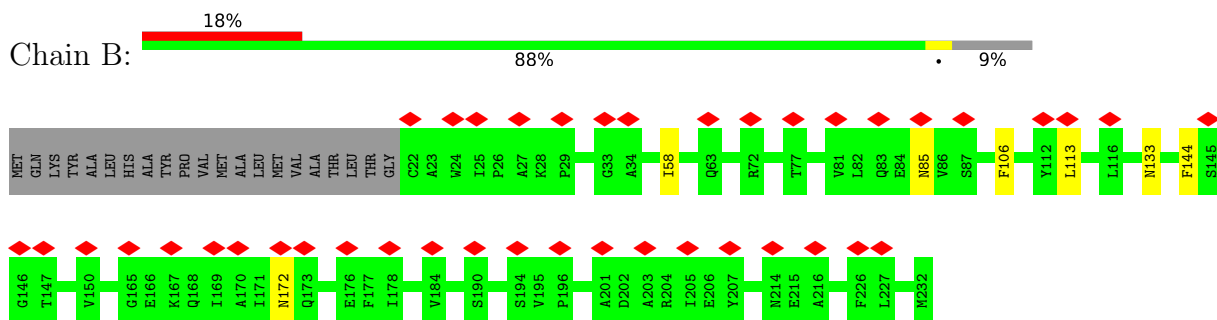

• Molecule 2: Flagellar L-ring protein

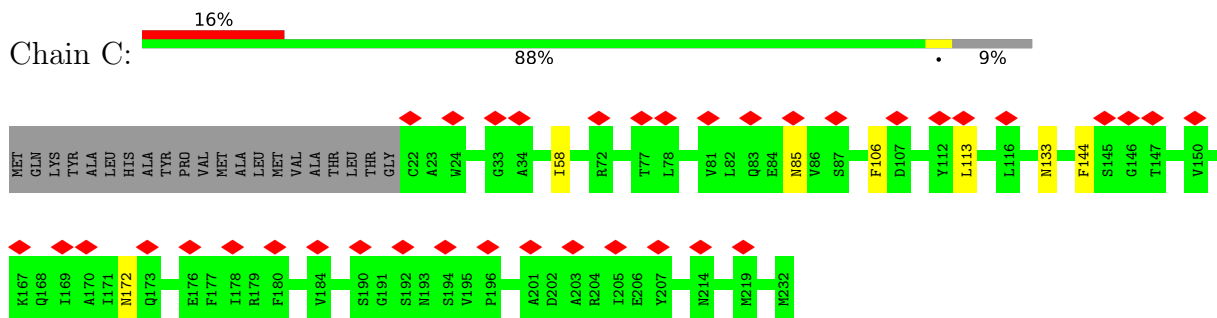

• Molecule 2: Flagellar L-ring protein

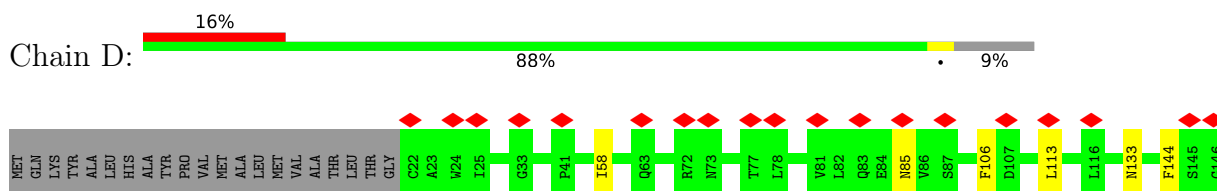

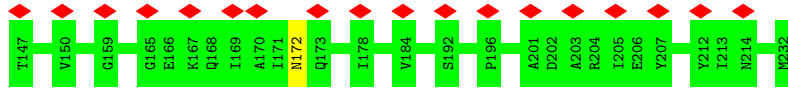

• Molecule 2: Flagellar L-ring protein

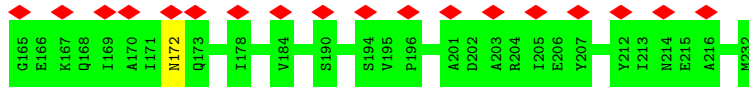
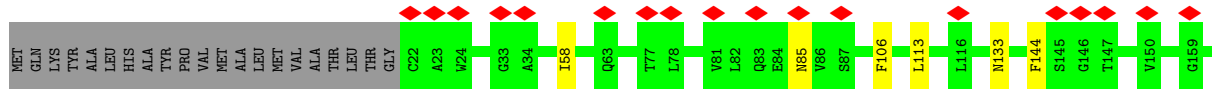
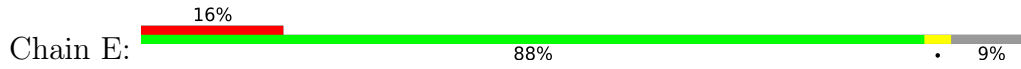

• Molecule 2: Flagellar L-ring protein

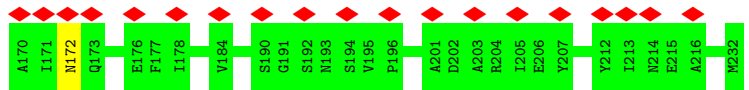
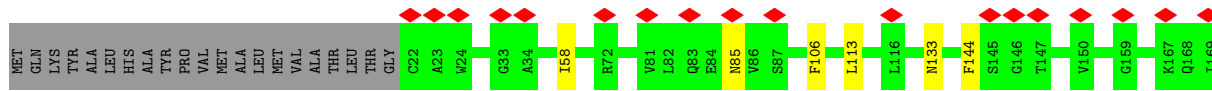
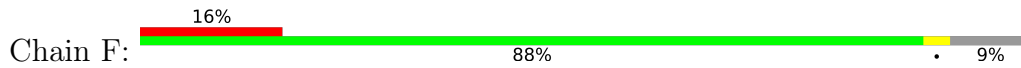

• Molecule 2: Flagellar L-ring protein

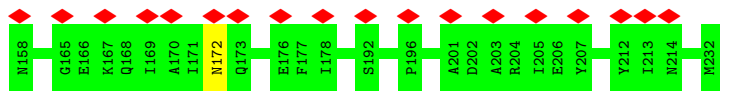
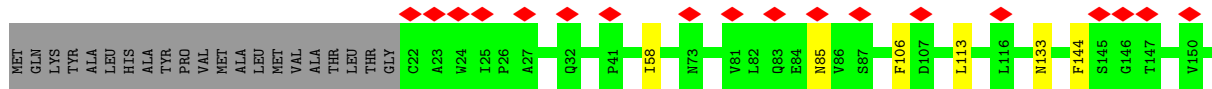
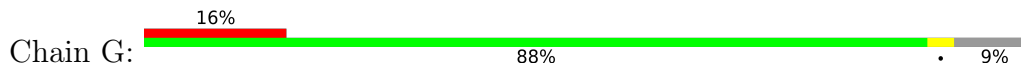

• Molecule 2: Flagellar L-ring protein

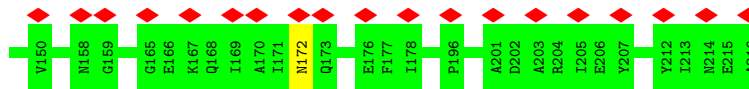
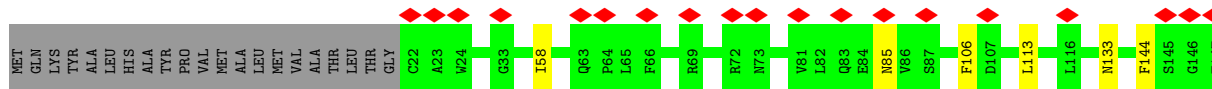
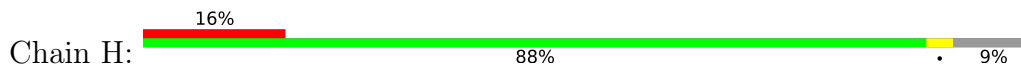

• Molecule 2: Flagellar L-ring protein

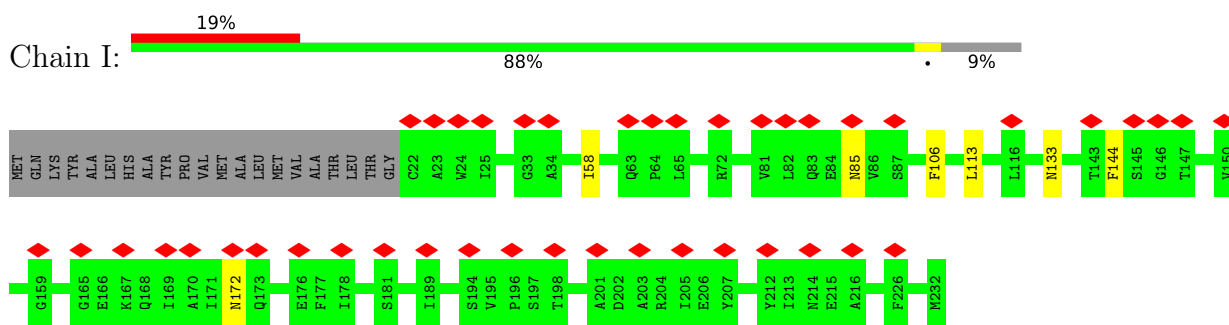

• Molecule 2: Flagellar L-ring protein

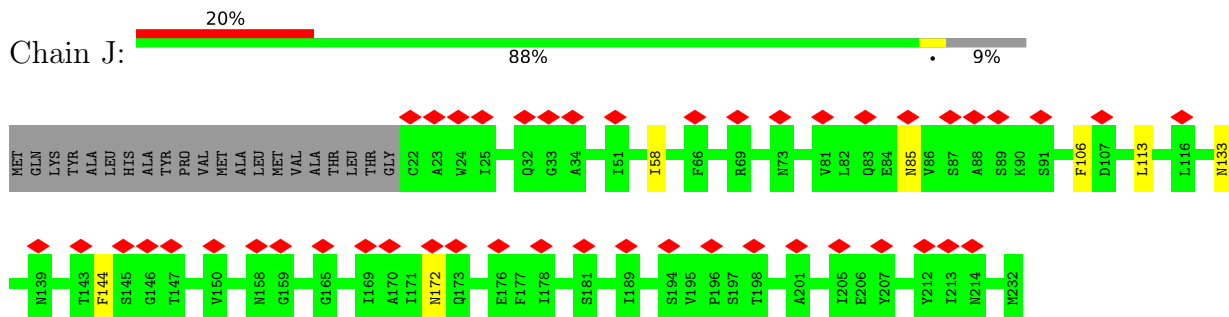

• Molecule 2: Flagellar L-ring protein

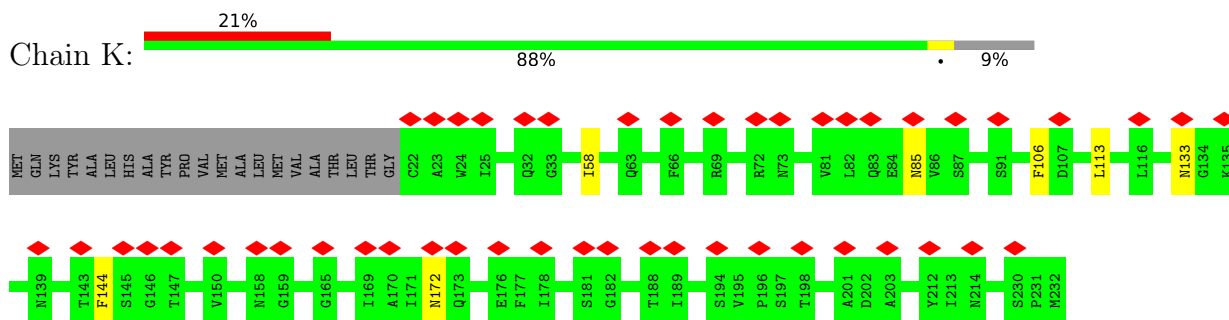

• Molecule 2: Flagellar L-ring protein

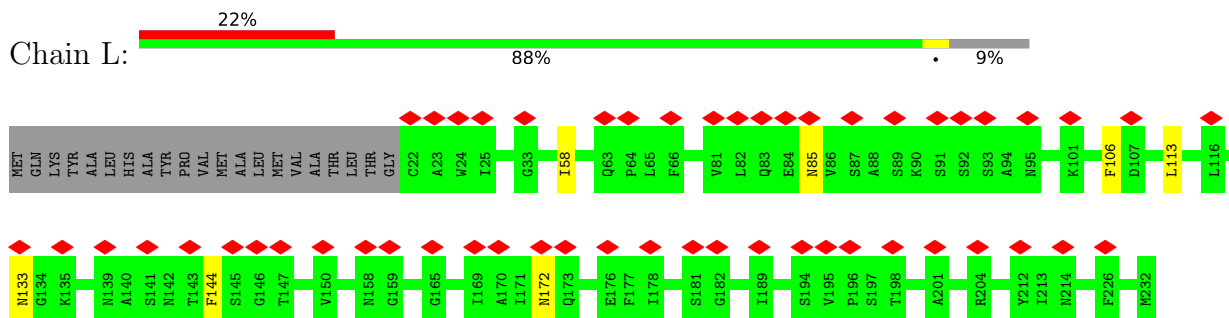

• Molecule 2: Flagellar L-ring protein

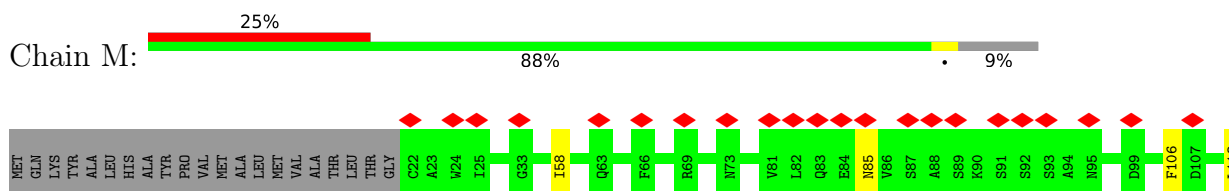

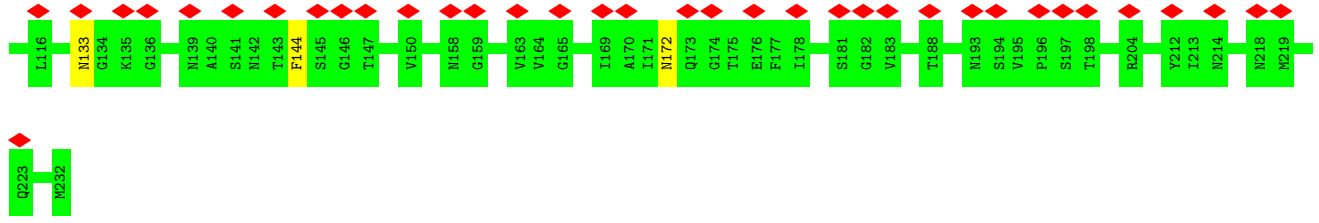

• Molecule 2: Flagellar L-ring protein

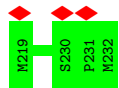
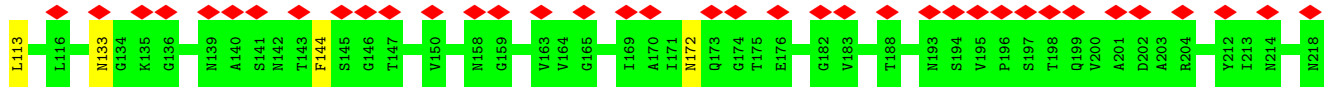
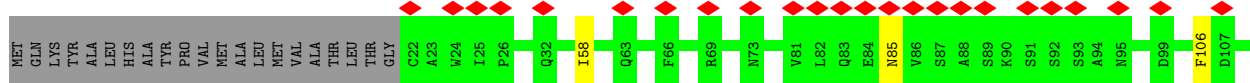
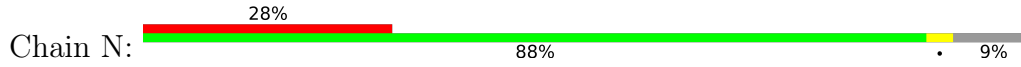

• Molecule 2: Flagellar L-ring protein

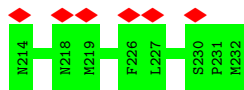
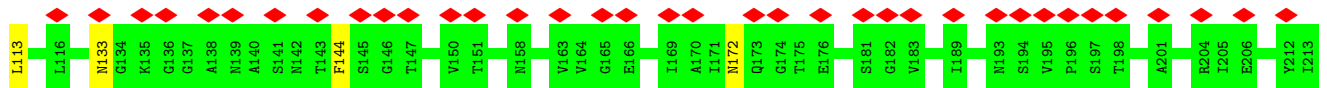
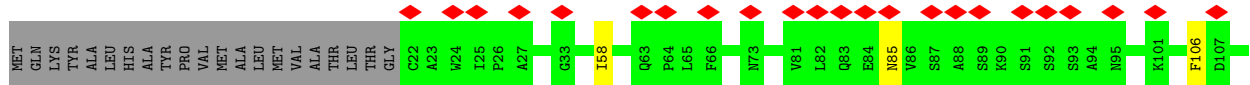
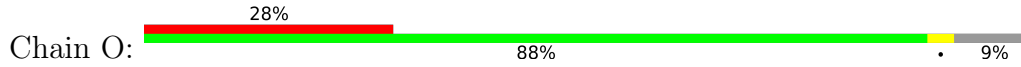

• Molecule 2: Flagellar L-ring protein

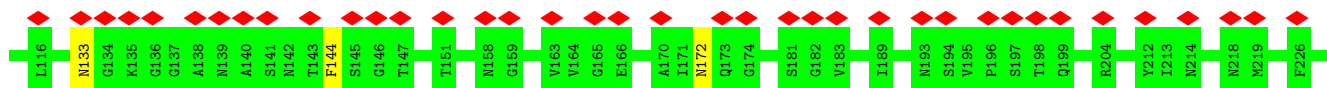
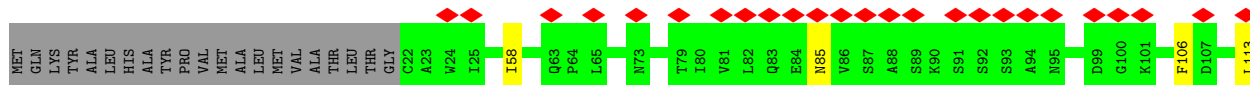
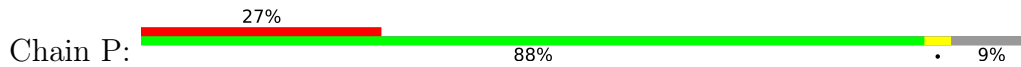

• Molecule 2: Flagellar L-ring protein

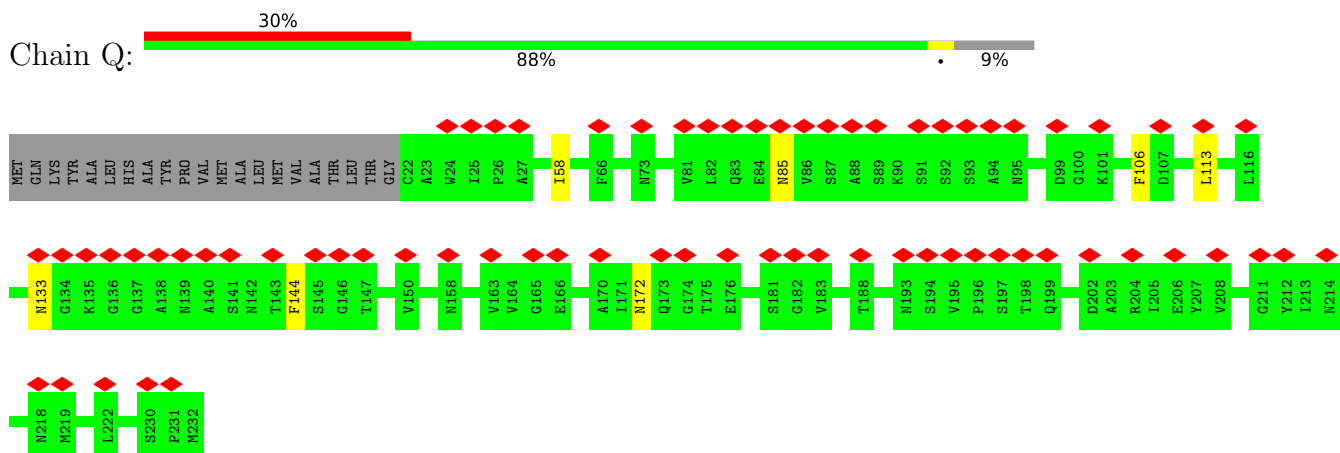

• Molecule 2: Flagellar L-ring protein

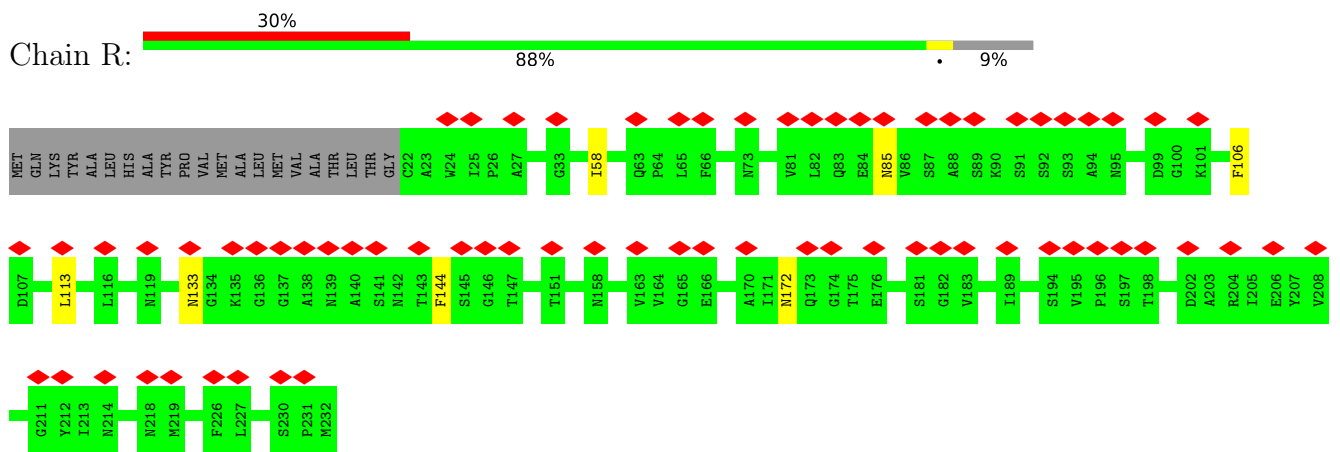

• Molecule 2: Flagellar L-ring protein

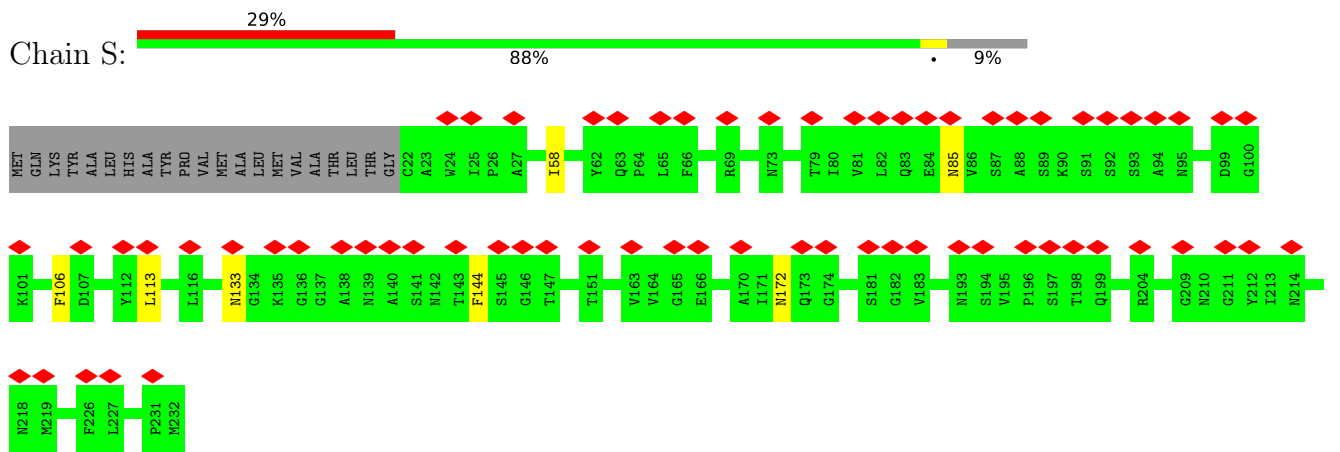

• Molecule 2: Flagellar L-ring protein



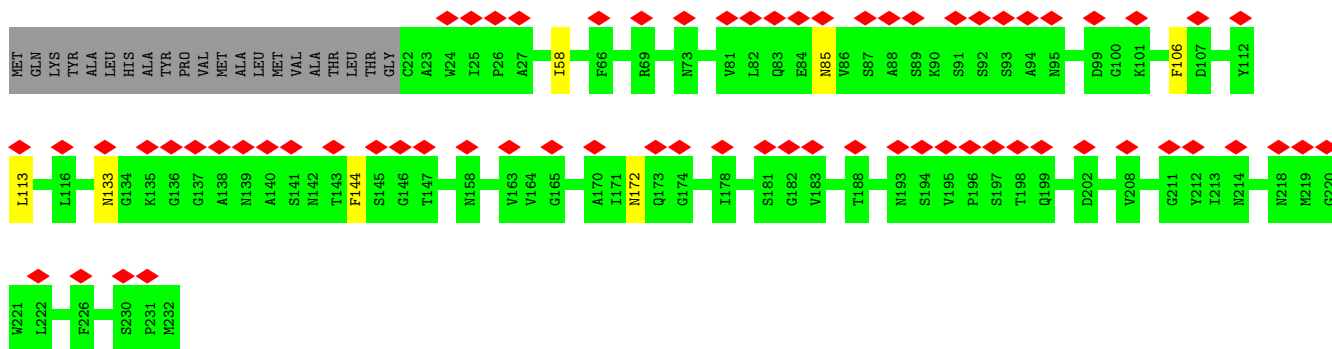

• Molecule 2: Flagellar L-ring protein

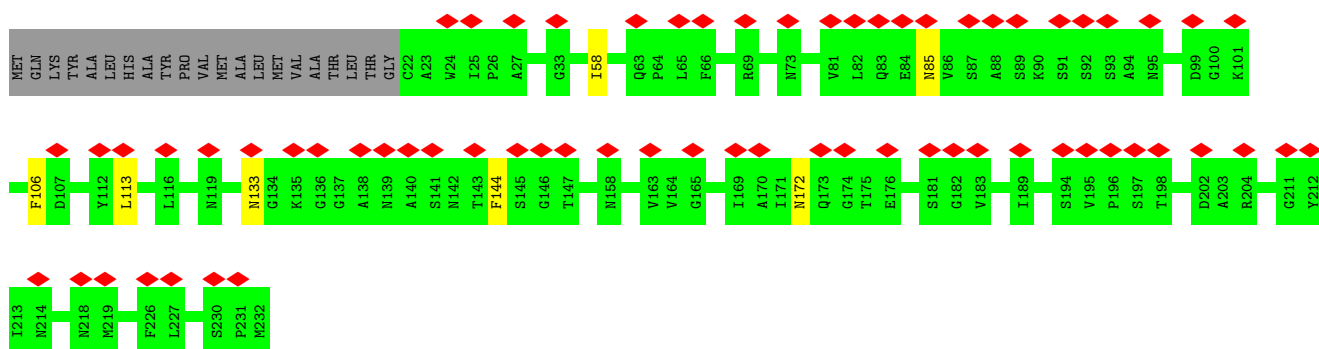
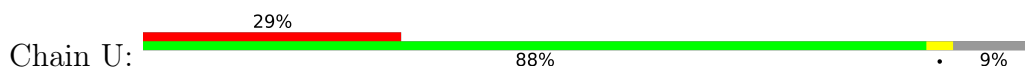

• Molecule 2: Flagellar L-ring protein

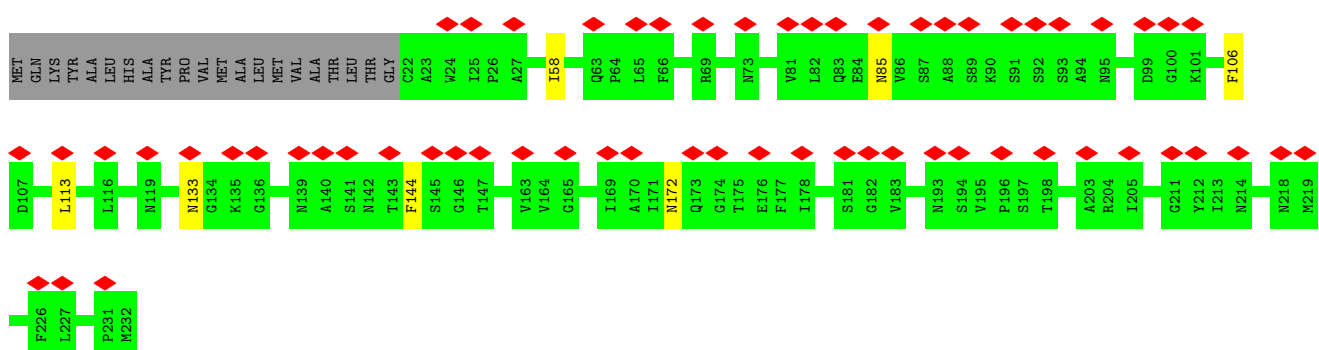
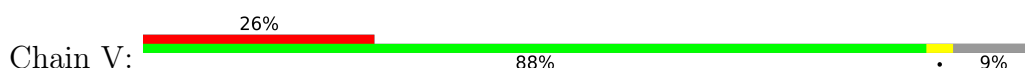

• Molecule 2: Flagellar L-ring protein

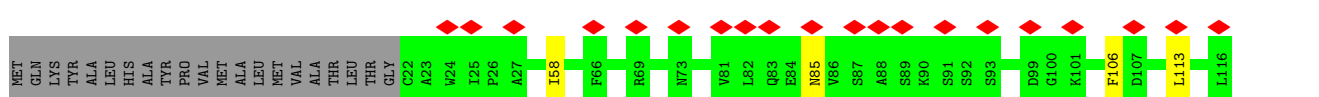

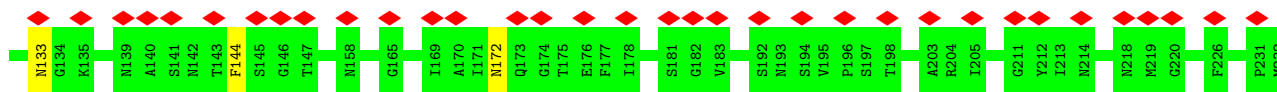

• Molecule 2: Flagellar L-ring protein

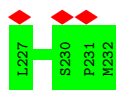
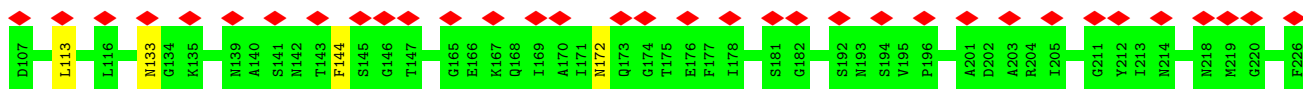
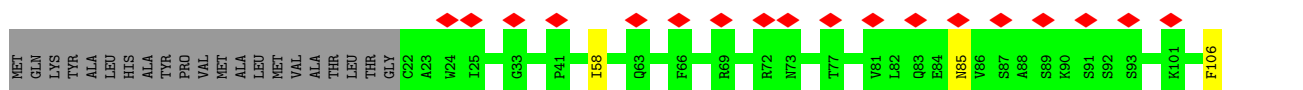
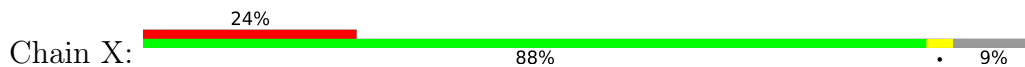

• Molecule 2: Flagellar L-ring protein

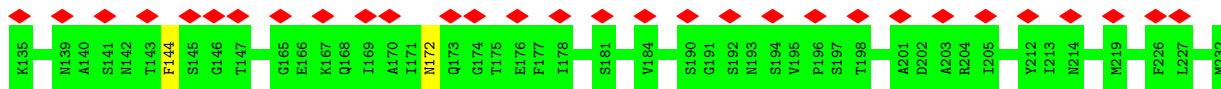
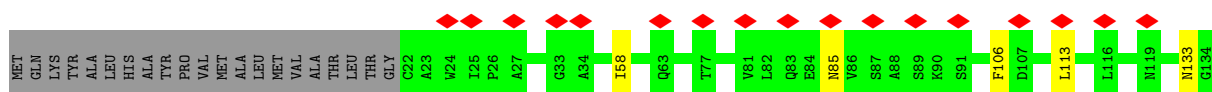
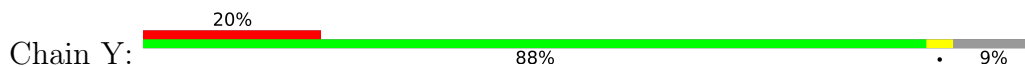

• Molecule 2: Flagellar L-ring protein

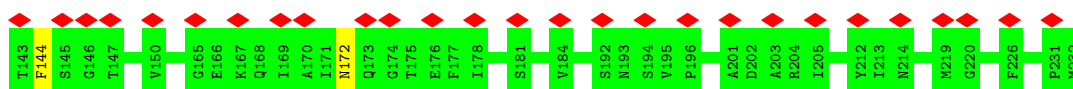
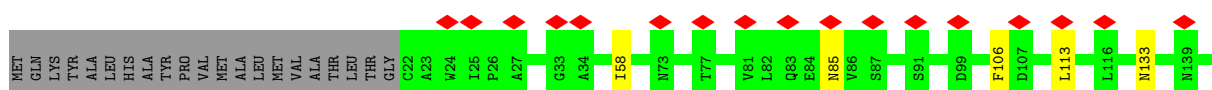
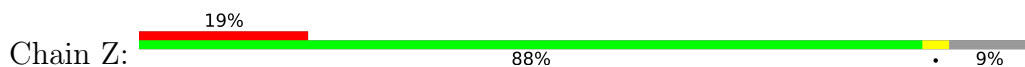

• Molecule 3: Flagellar basal body rod protein FlgB

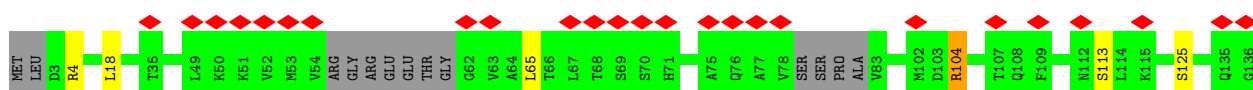
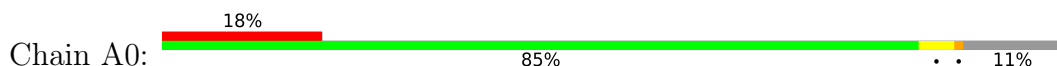

- Molecule 3: Flagellar basal body rod protein FlgB

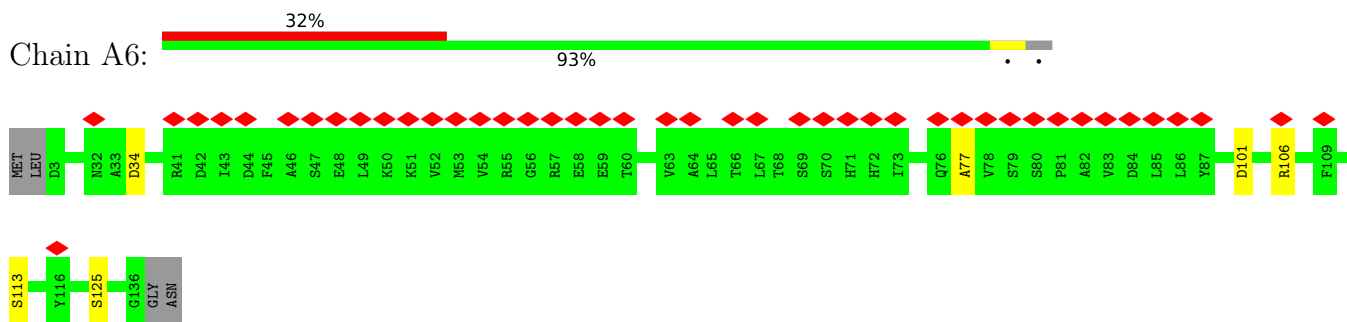

- Molecule 3: Flagellar basal body rod protein FlgB

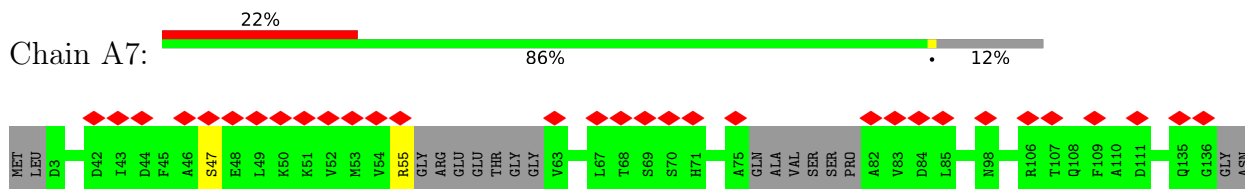

- Molecule 3: Flagellar basal body rod protein FlgB

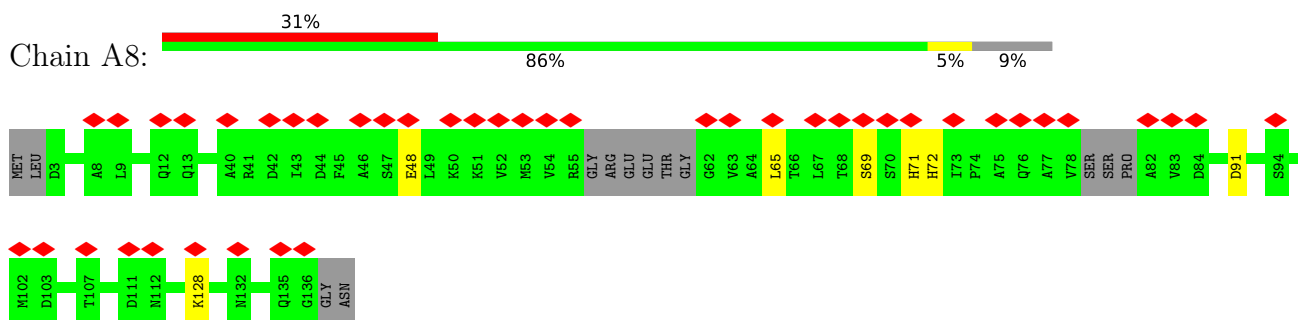

- Molecule 3: Flagellar basal body rod protein FlgB

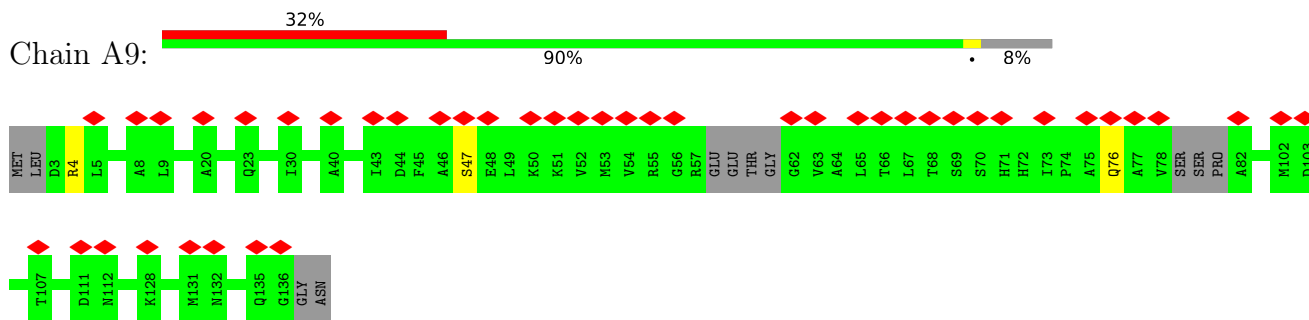

- Molecule 4: Flagellar hook-basal body complex protein FliE

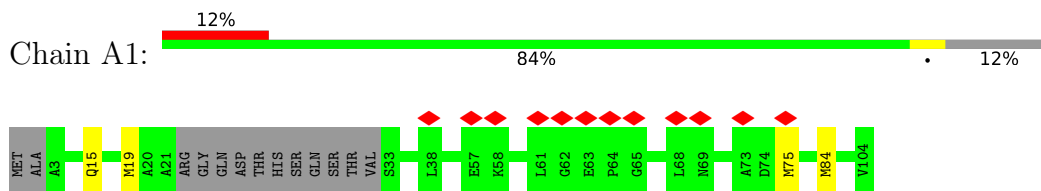

- Molecule 4: Flagellar hook-basal body complex protein FliE

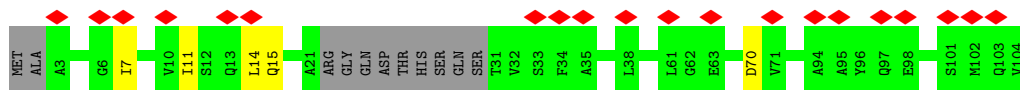
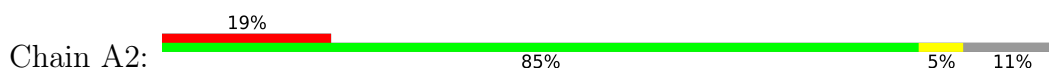

• Molecule 4: Flagellar hook-basal body complex protein FliE

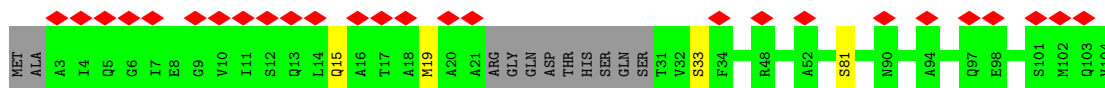
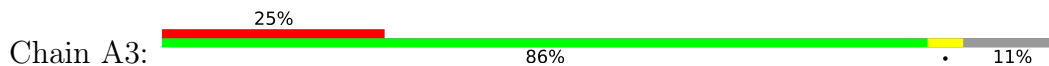

• Molecule 4: Flagellar hook-basal body complex protein FliE

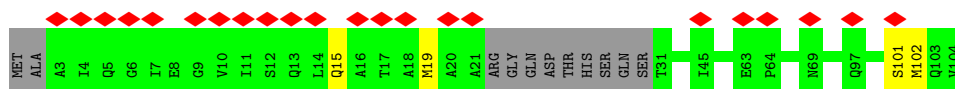
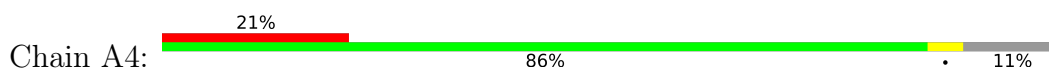

• Molecule 4: Flagellar hook-basal body complex protein FliE

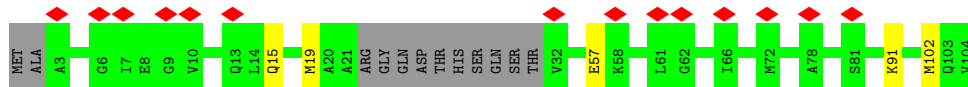
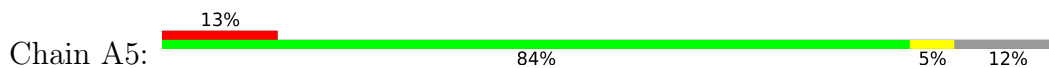

• Molecule 4: Flagellar hook-basal body complex protein FliE

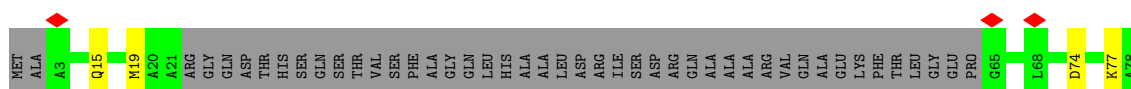

• Molecule 5: Flagellar basal-body rod protein FlgF

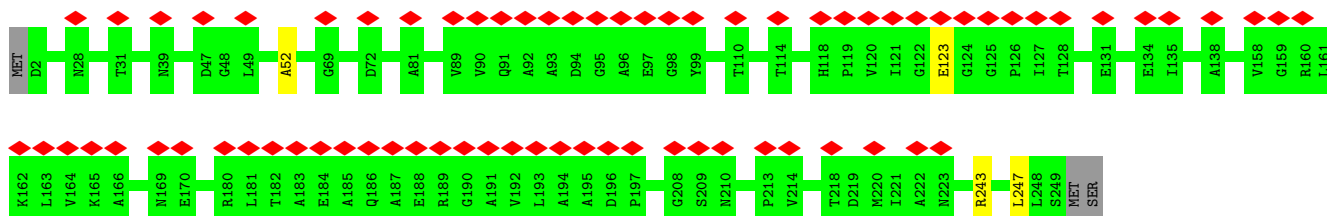

- Molecule 5: Flagellar basal-body rod protein FlgF

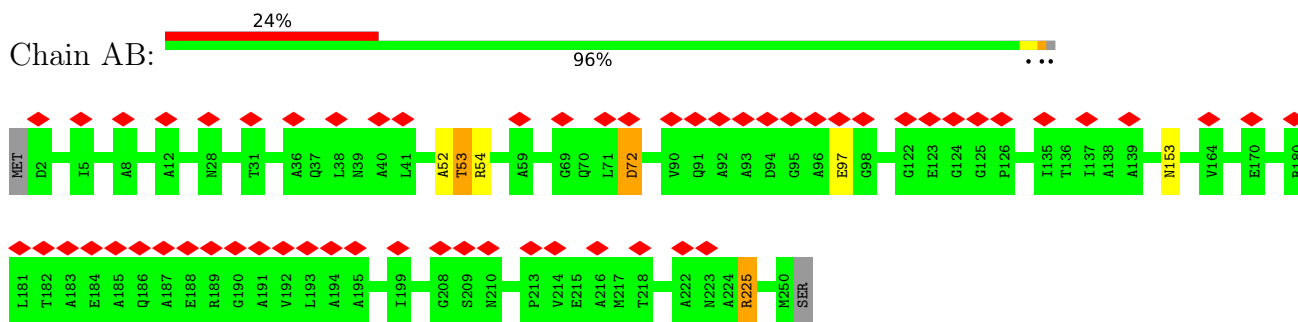

- Molecule 5: Flagellar basal-body rod protein FlgF

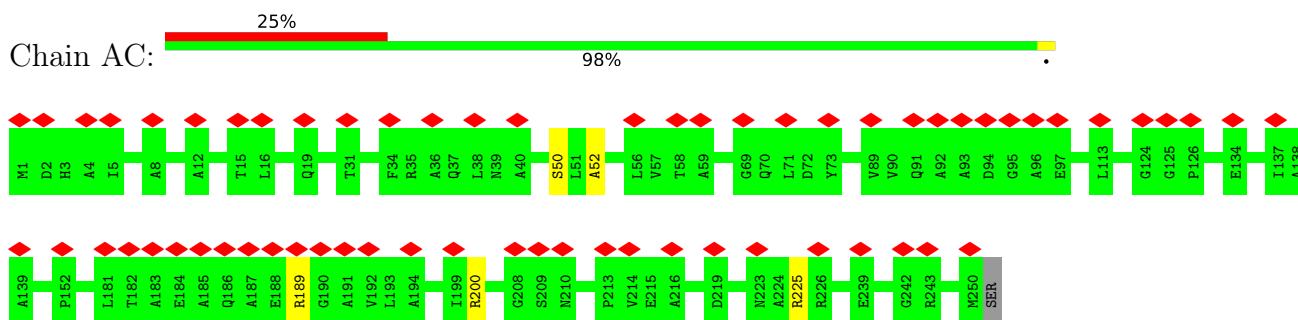

- Molecule 5: Flagellar basal-body rod protein FlgF

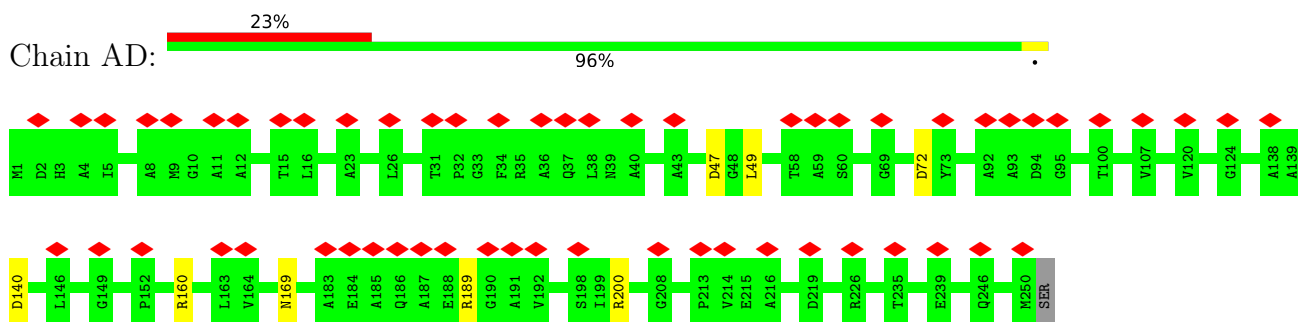

- Molecule 5: Flagellar basal-body rod protein FlgF

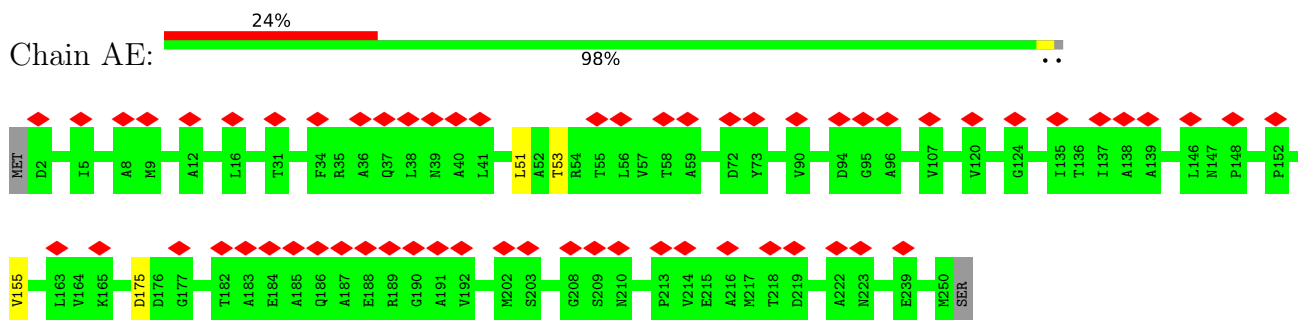

- Molecule 6: Flagellar M-ring protein

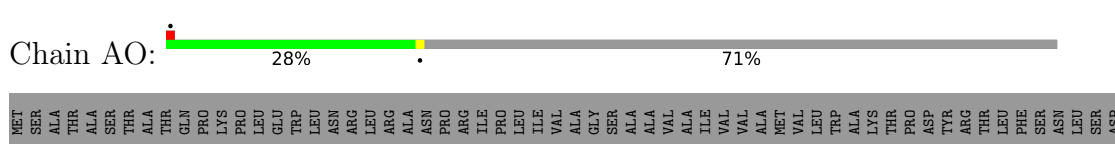

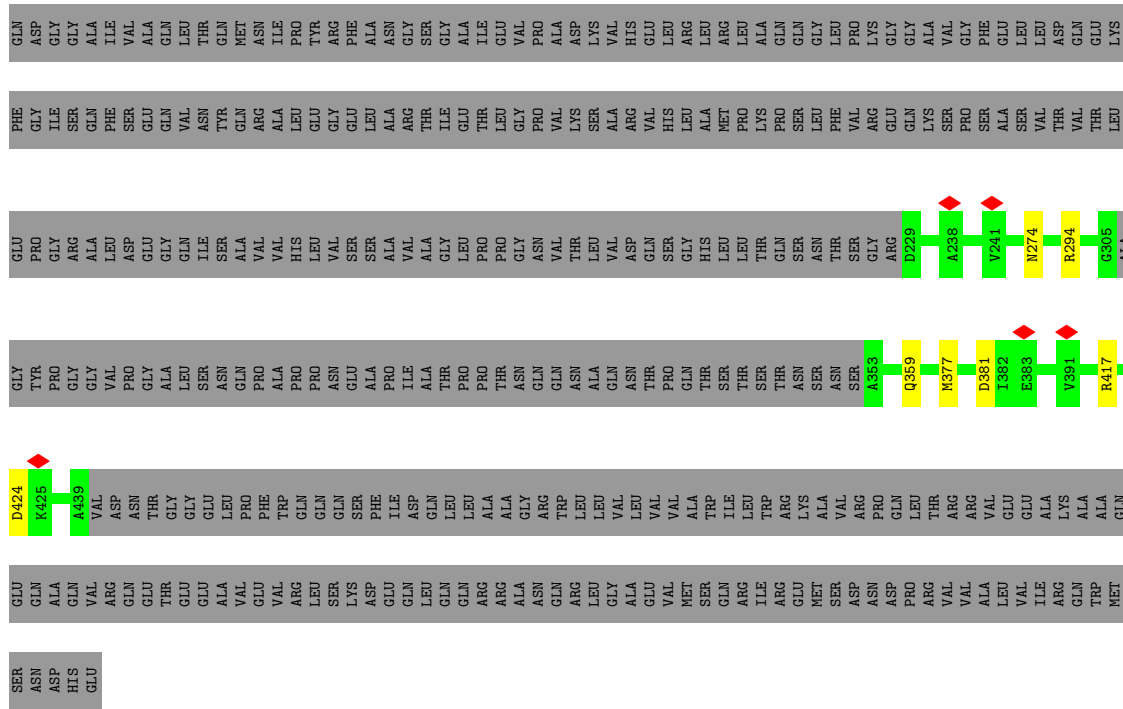

• Molecule 6: Flagellar M-ring protein

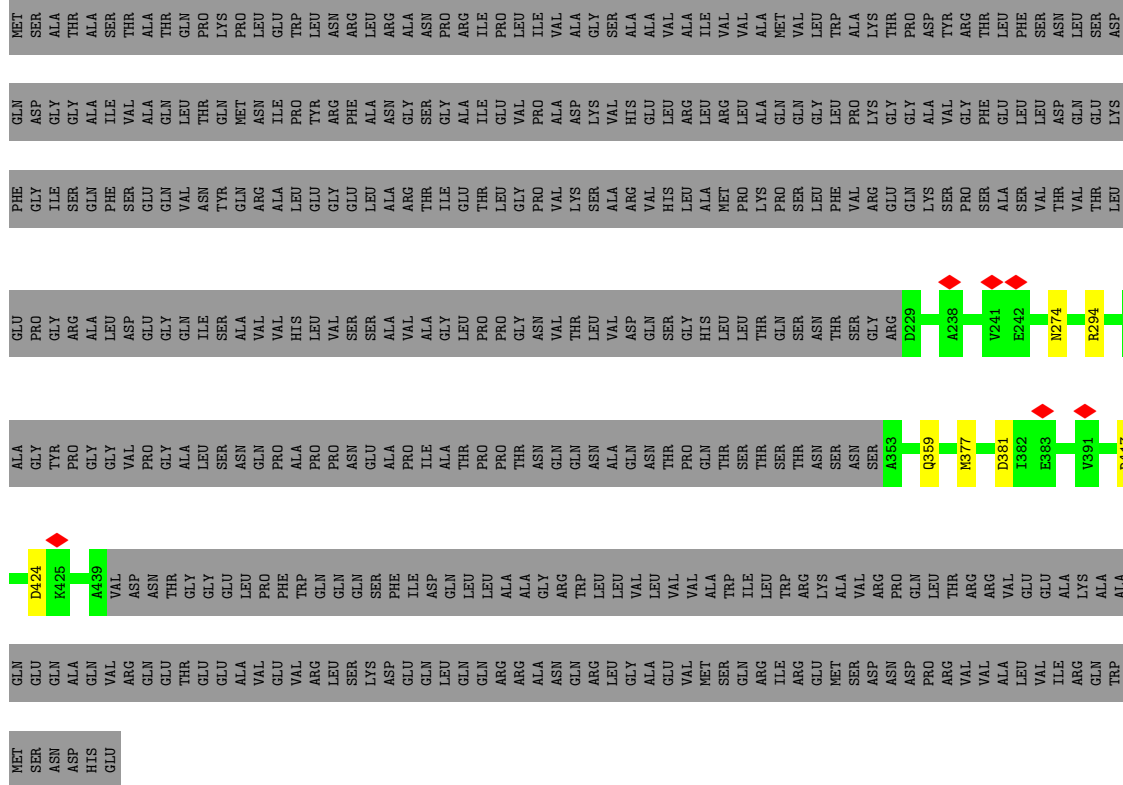

• Molecule 6: Flagellar M-ring protein

TRP
MET
SER
ASN
ASP
HIS
GLU

• Molecule 6: Flagellar M-ring protein

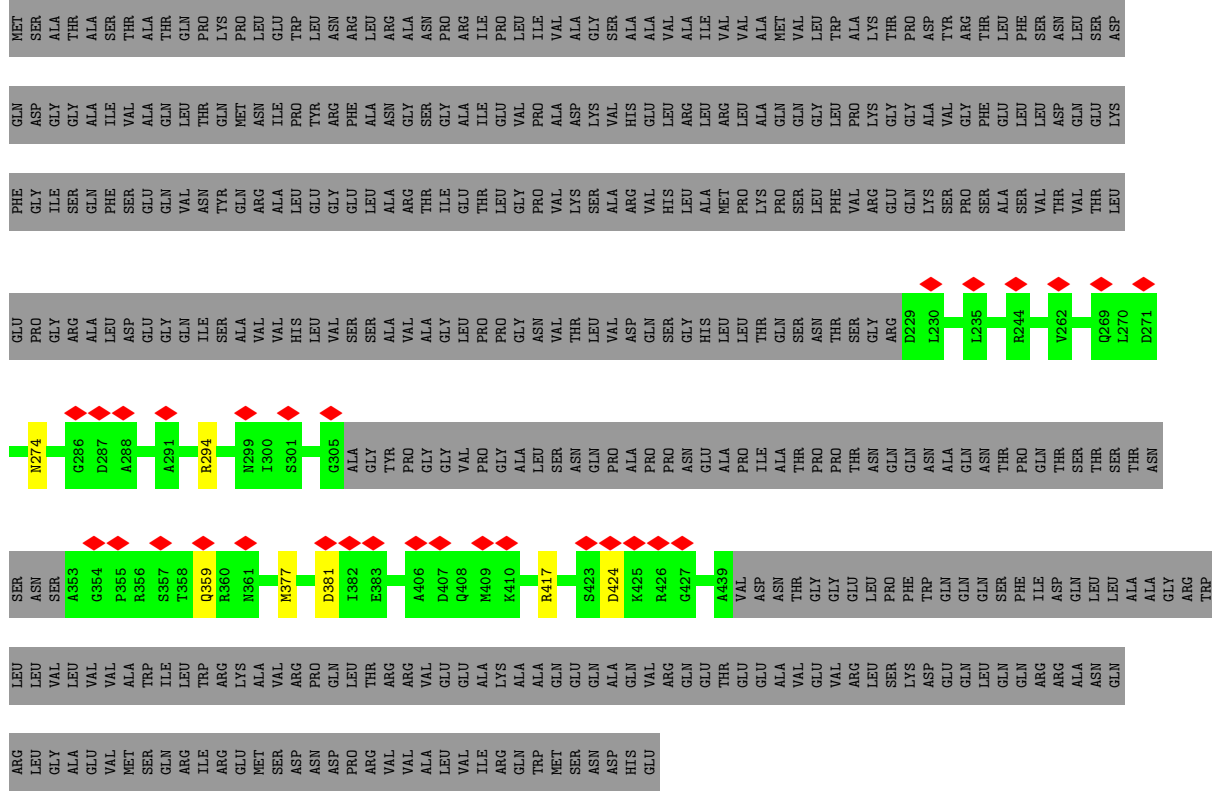

• Molecule 6: Flagellar M-ring protein



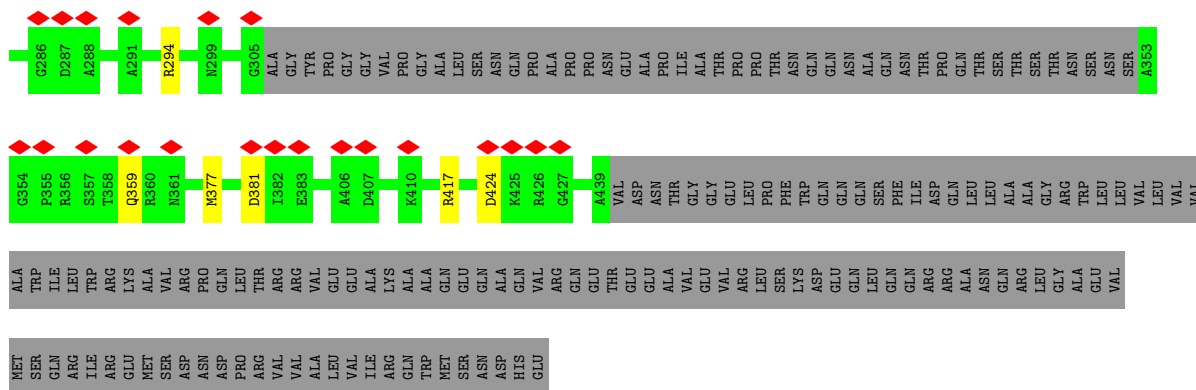

● Molecule 6: Flagellar M-ring protein

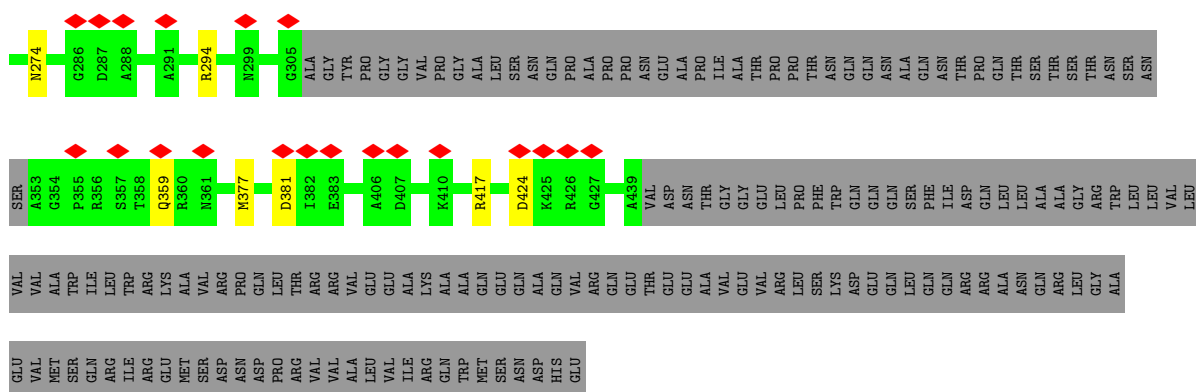
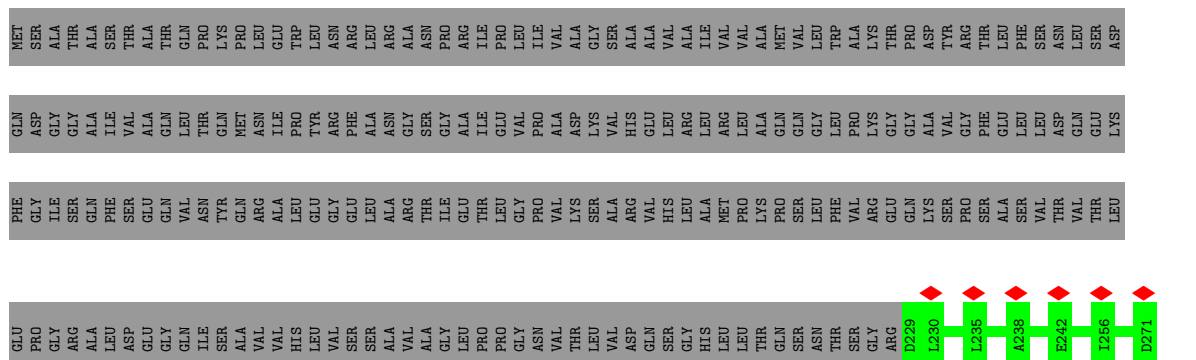

● Molecule 6: Flagellar M-ring protein

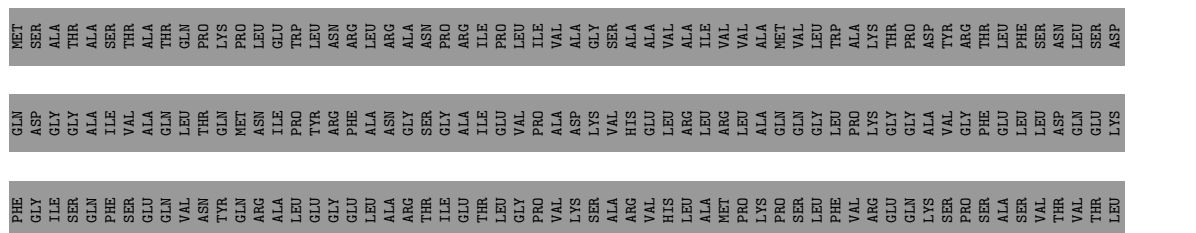

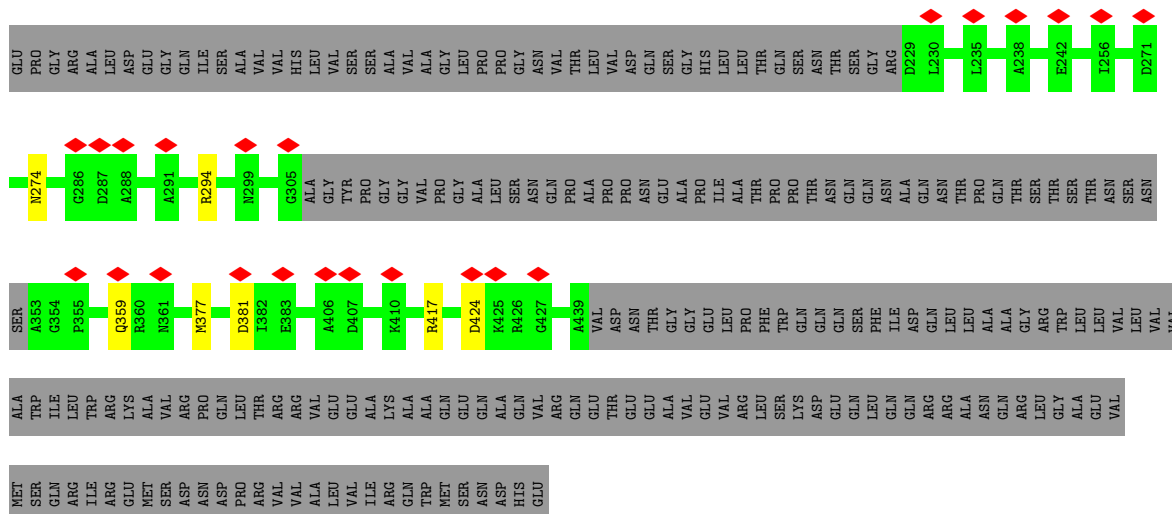

• Molecule 6: Flagellar M-ring protein

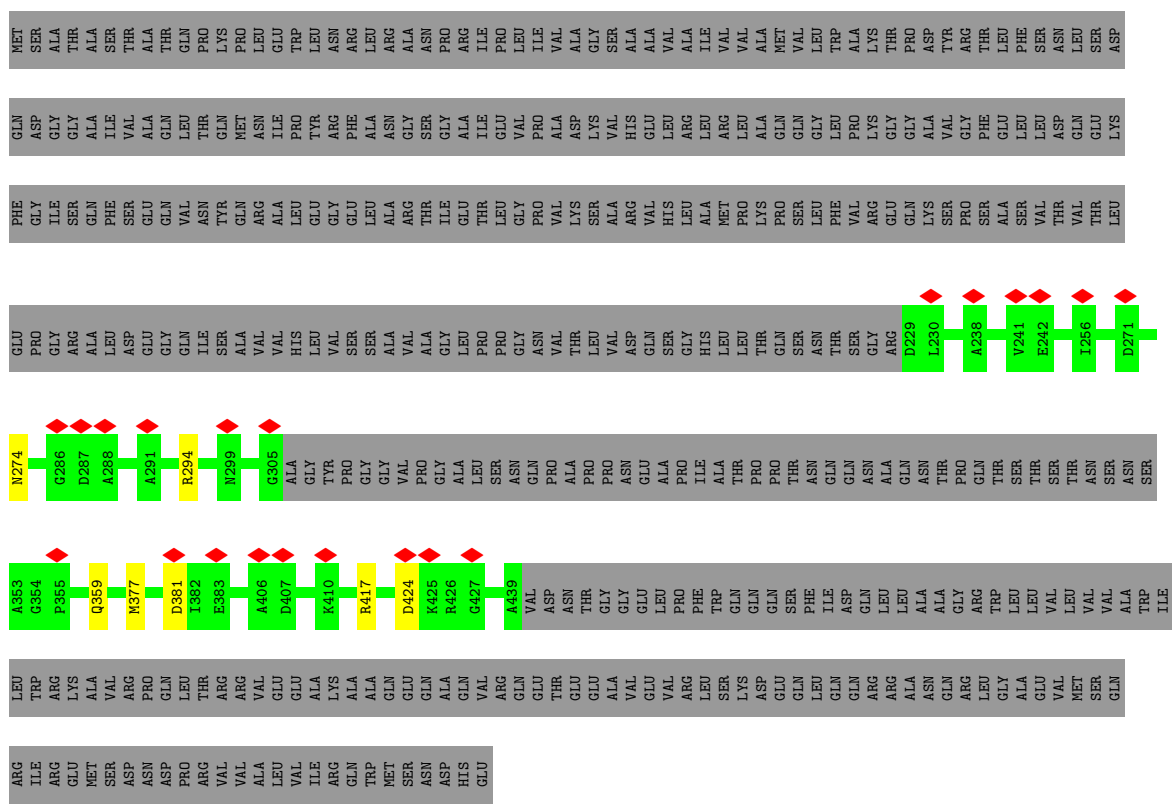

• Molecule 6: Flagellar M-ring protein



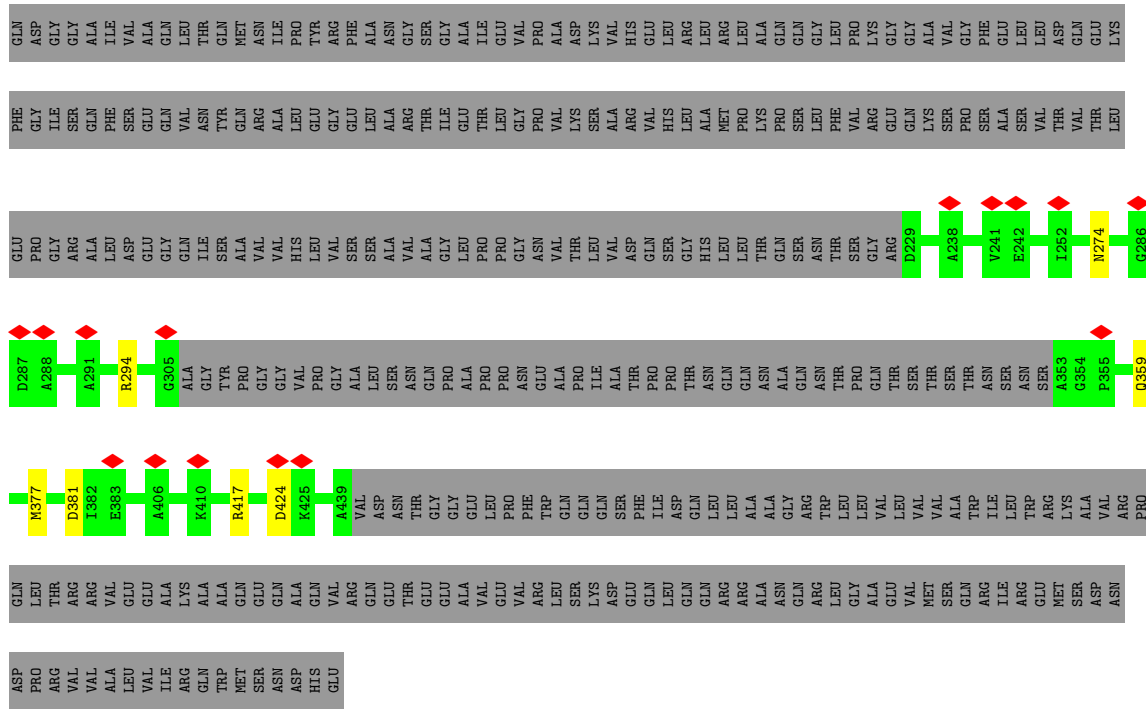

• Molecule 6: Flagellar M-ring protein



• Molecule 6: Flagellar M-ring protein

• Molecule 6: Flagellar M-ring protein

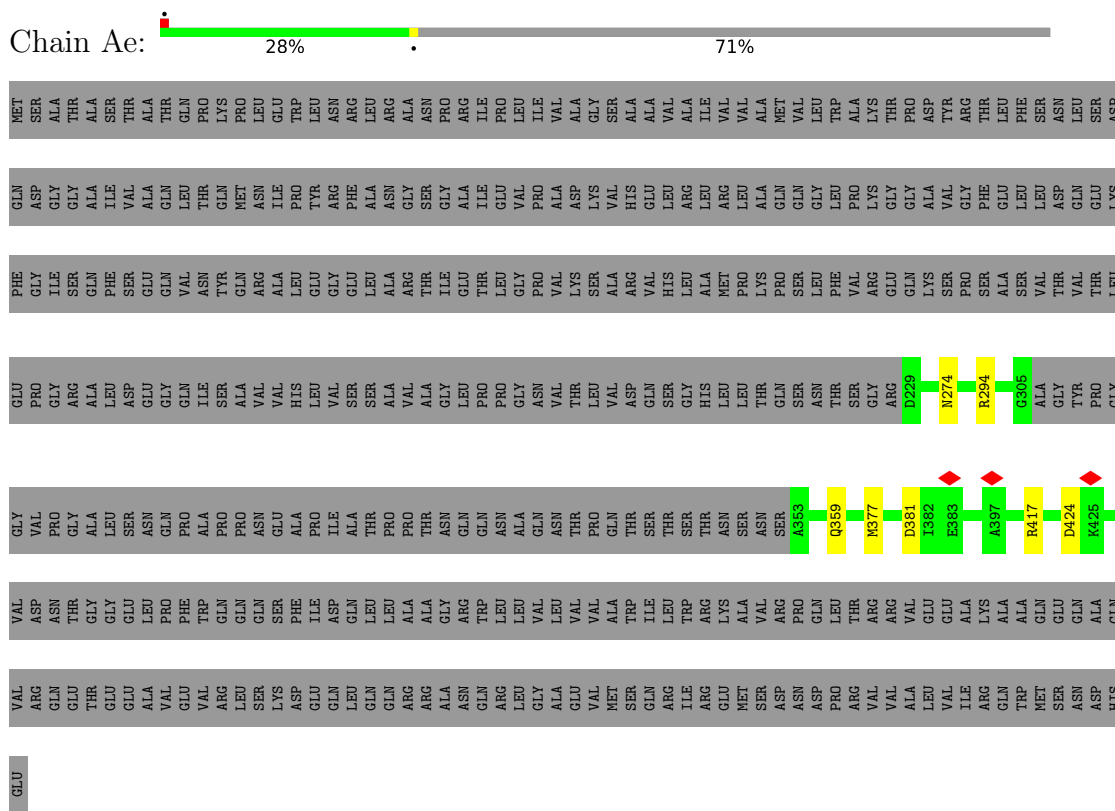

• Molecule 6: Flagellar M-ring protein

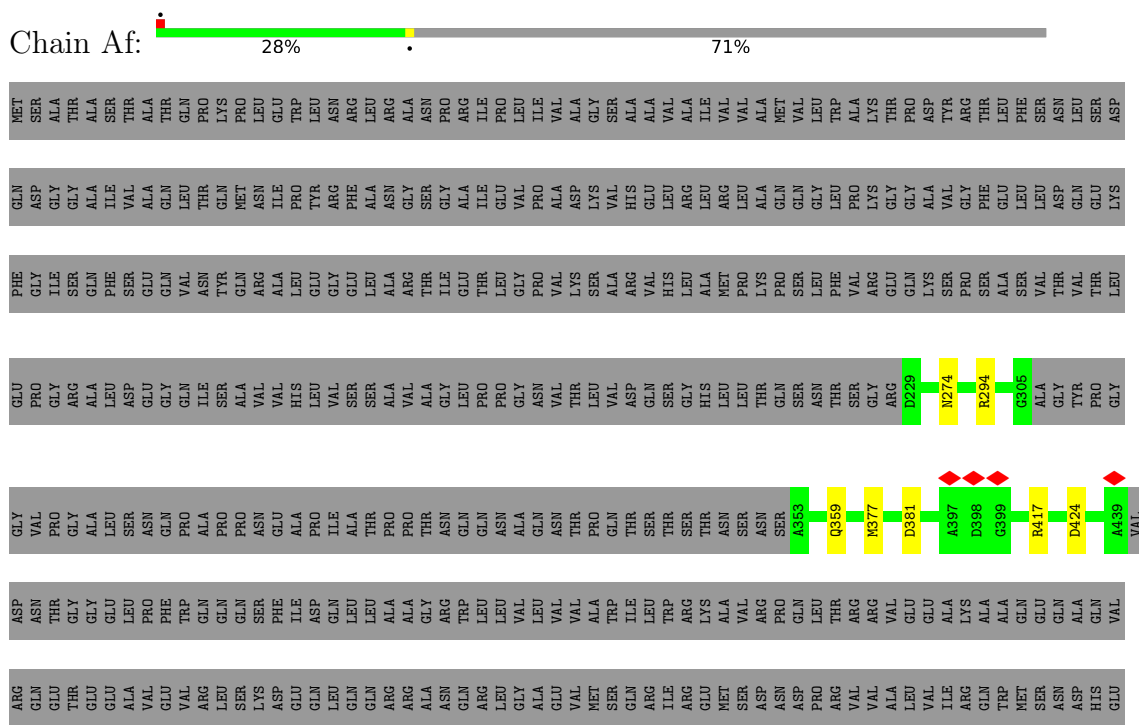

• Molecule 6: Flagellar M-ring protein

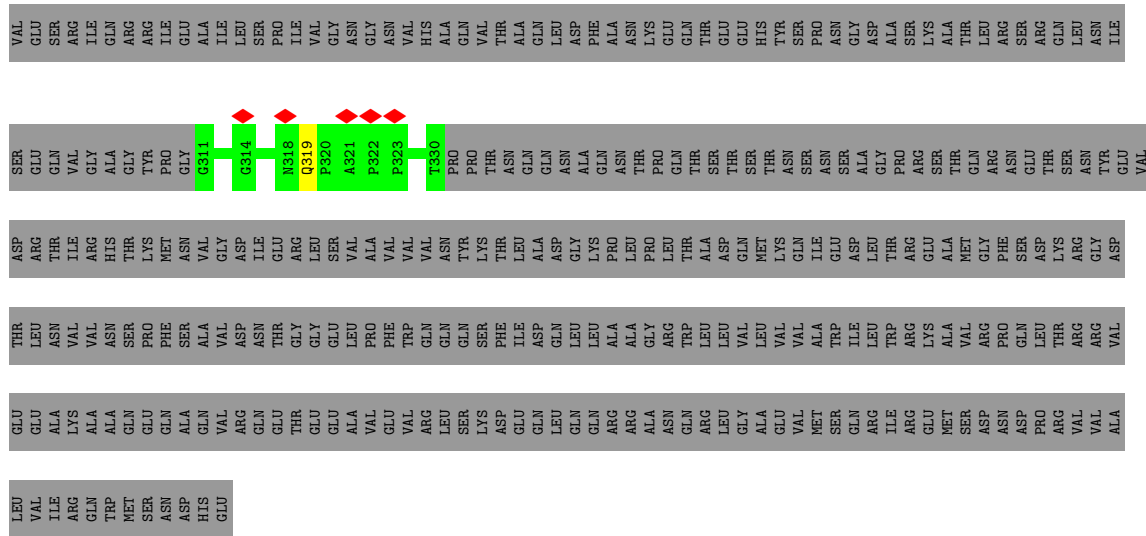

● Molecule 6: Flagellar M-ring protein

Chain BP: 97%

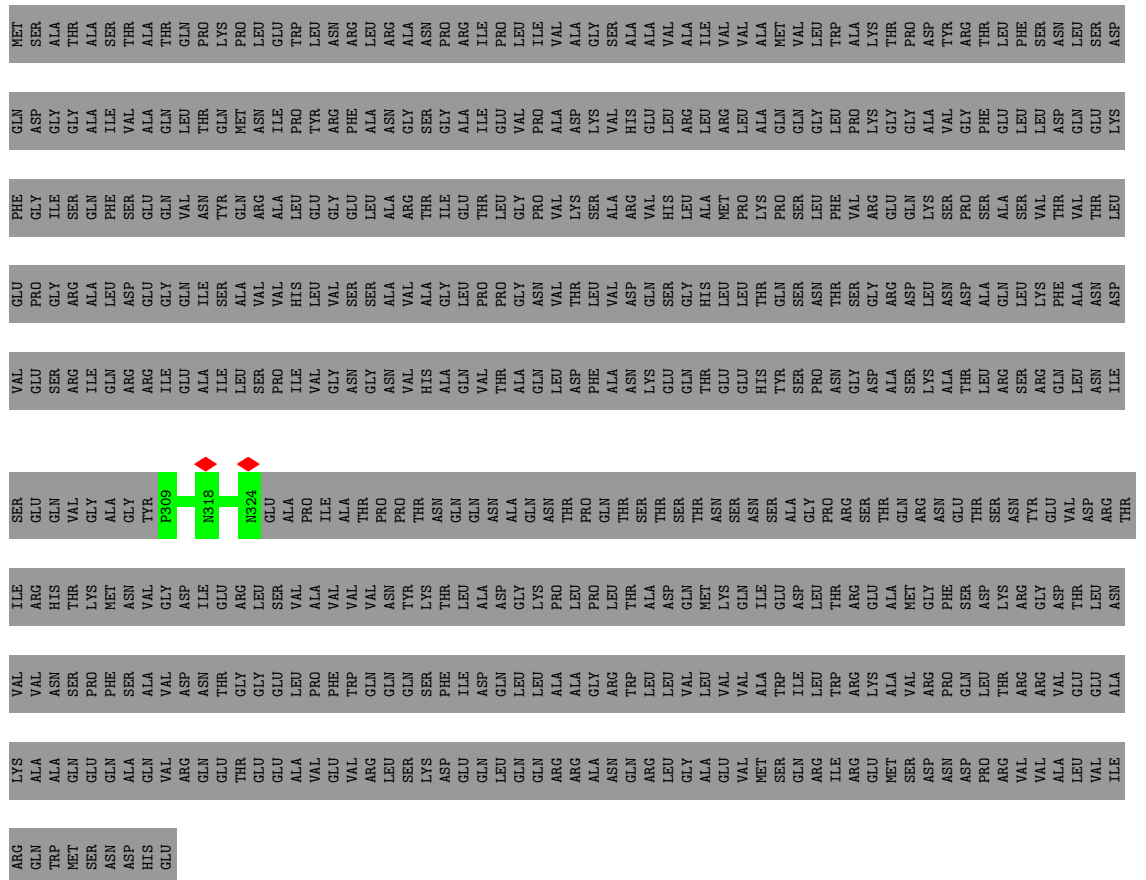

● Molecule 6: Flagellar M-ring protein

Chain BQ: 96%

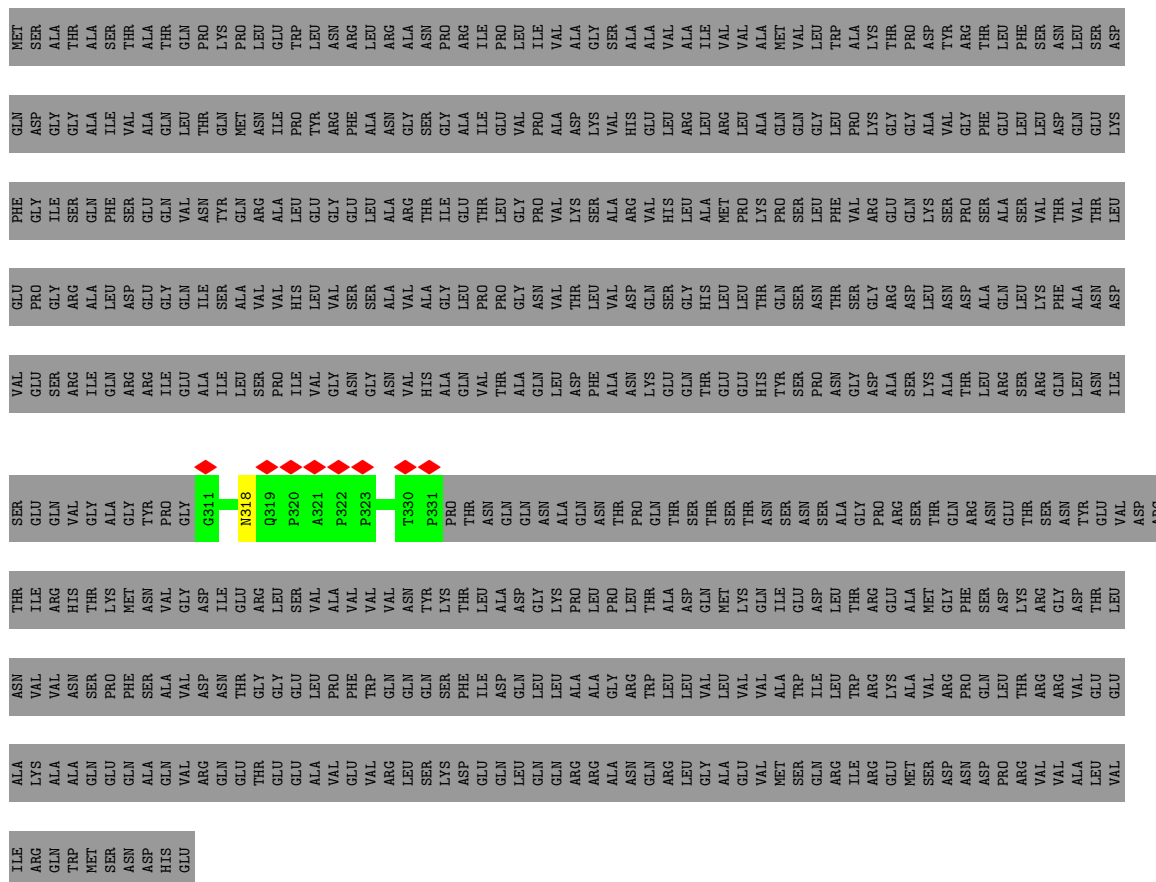

● Molecule 6: Flagellar M-ring protein

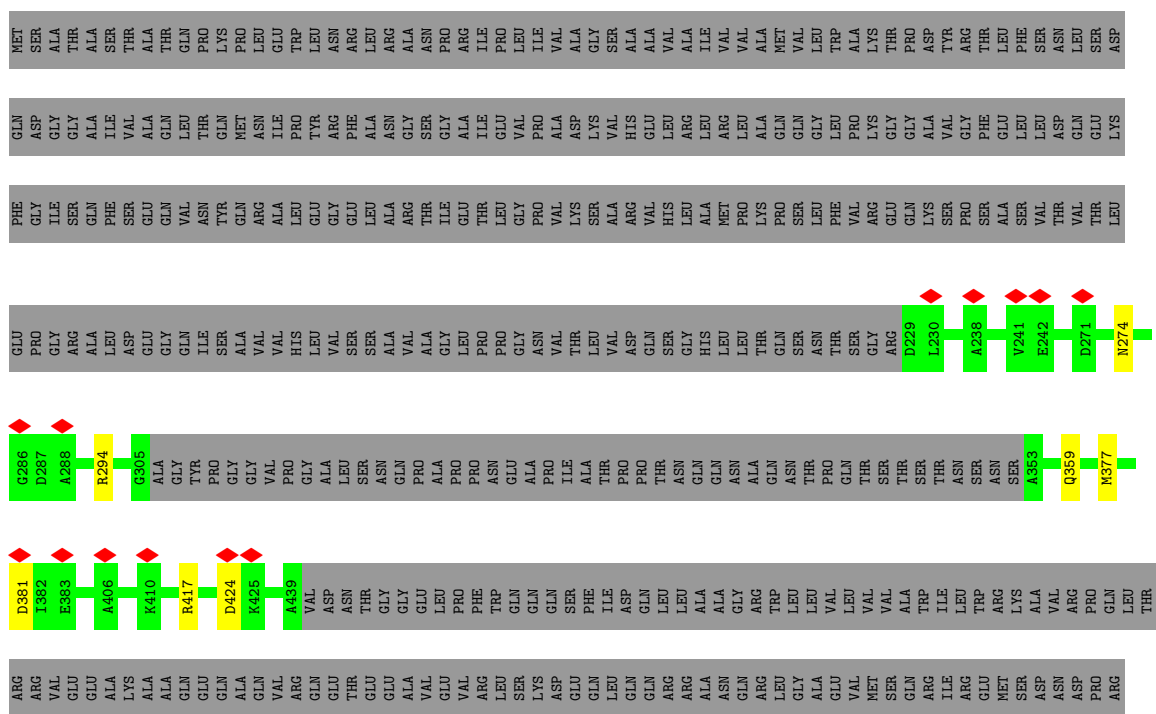

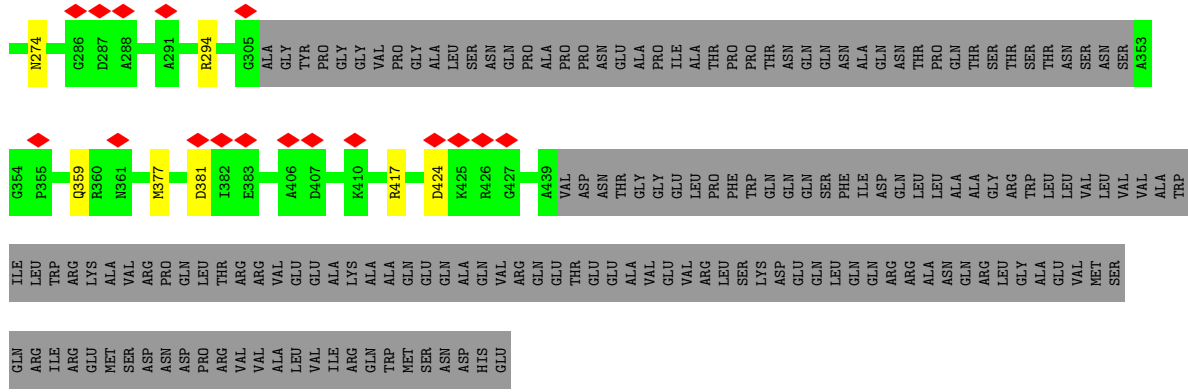

● Molecule 6: Flagellar M-ring protein

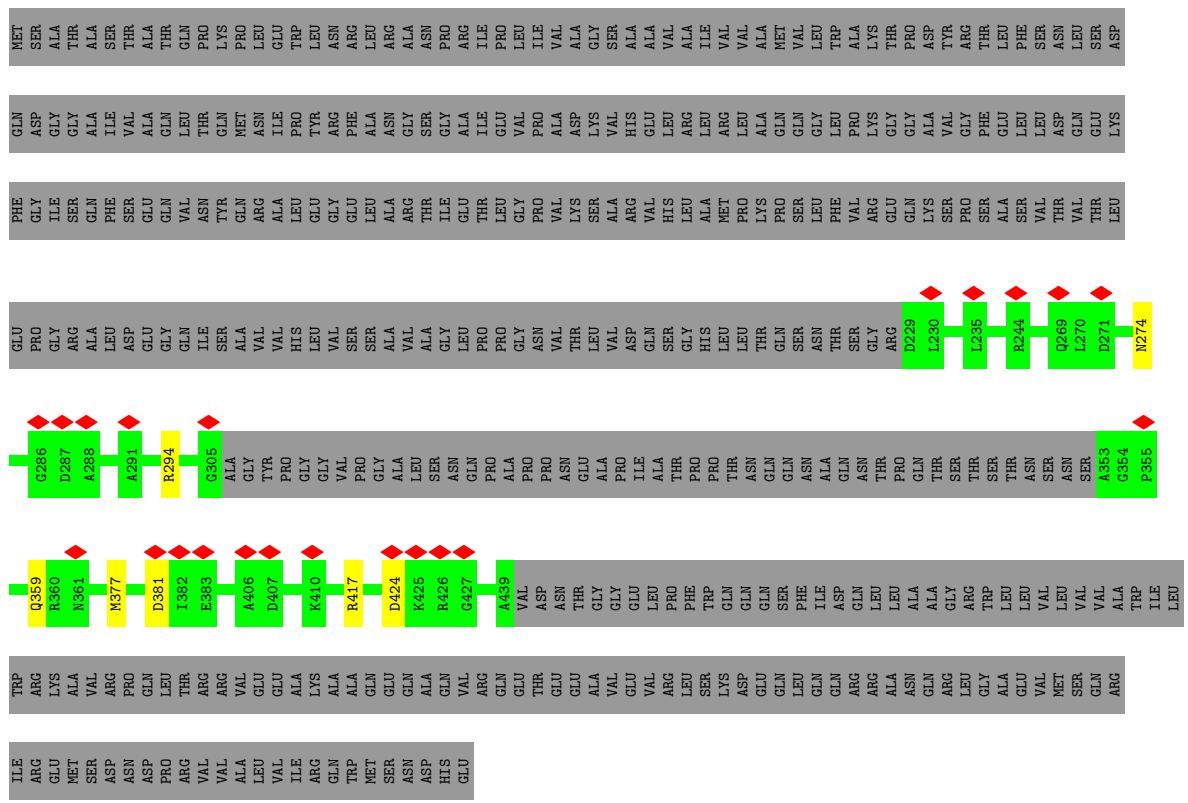

● Molecule 6: Flagellar M-ring protein

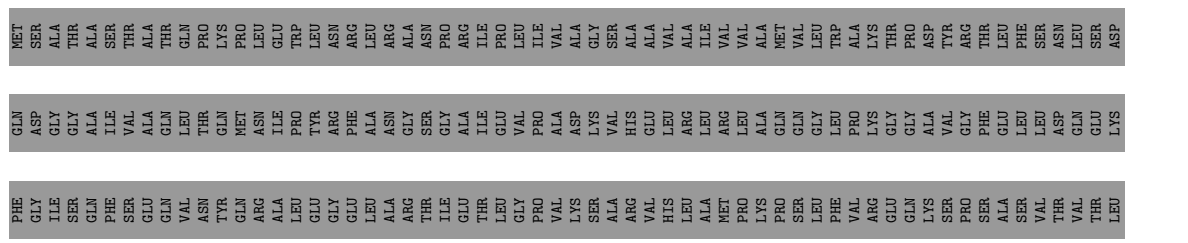

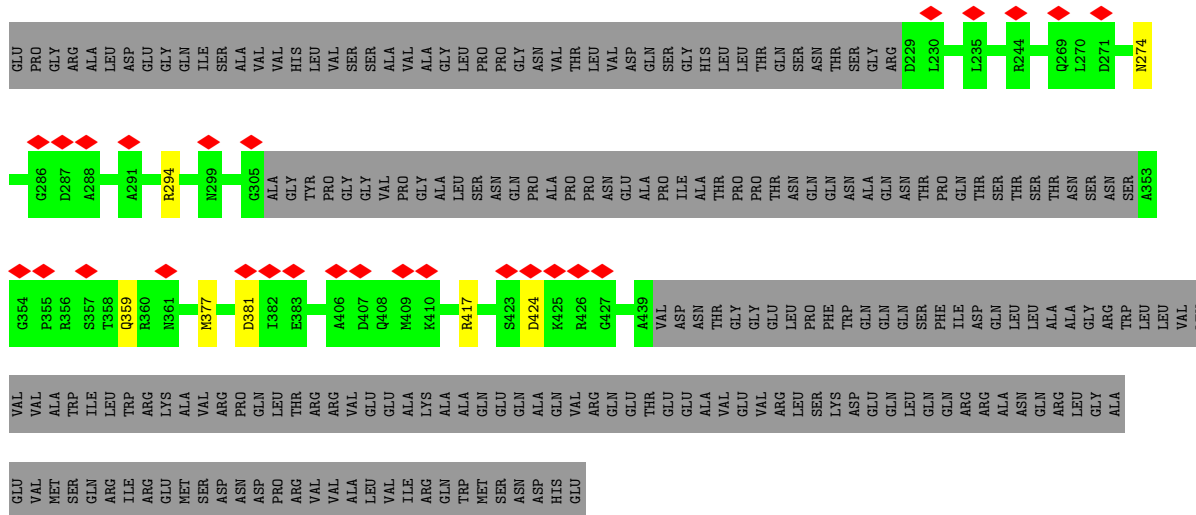

• Molecule 6: Flagellar M-ring protein

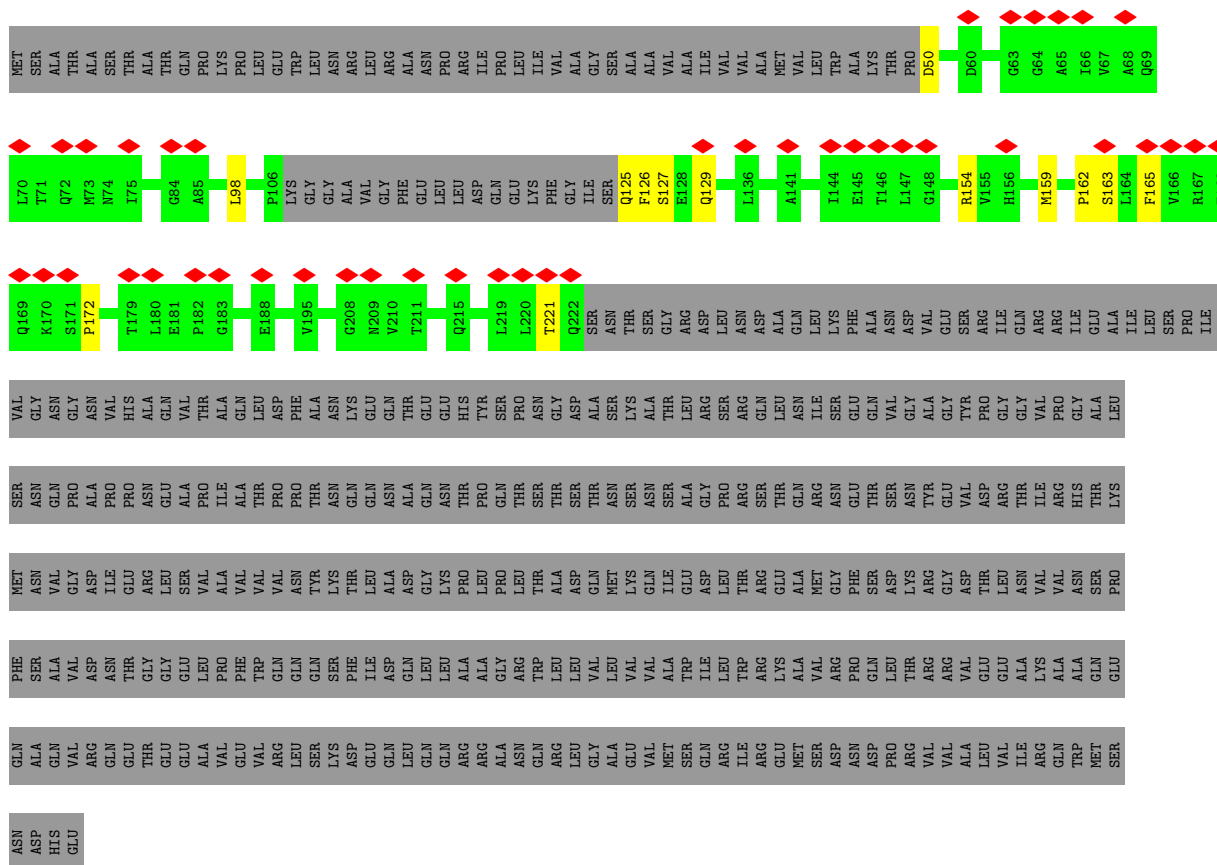

• Molecule 6: Flagellar M-ring protein



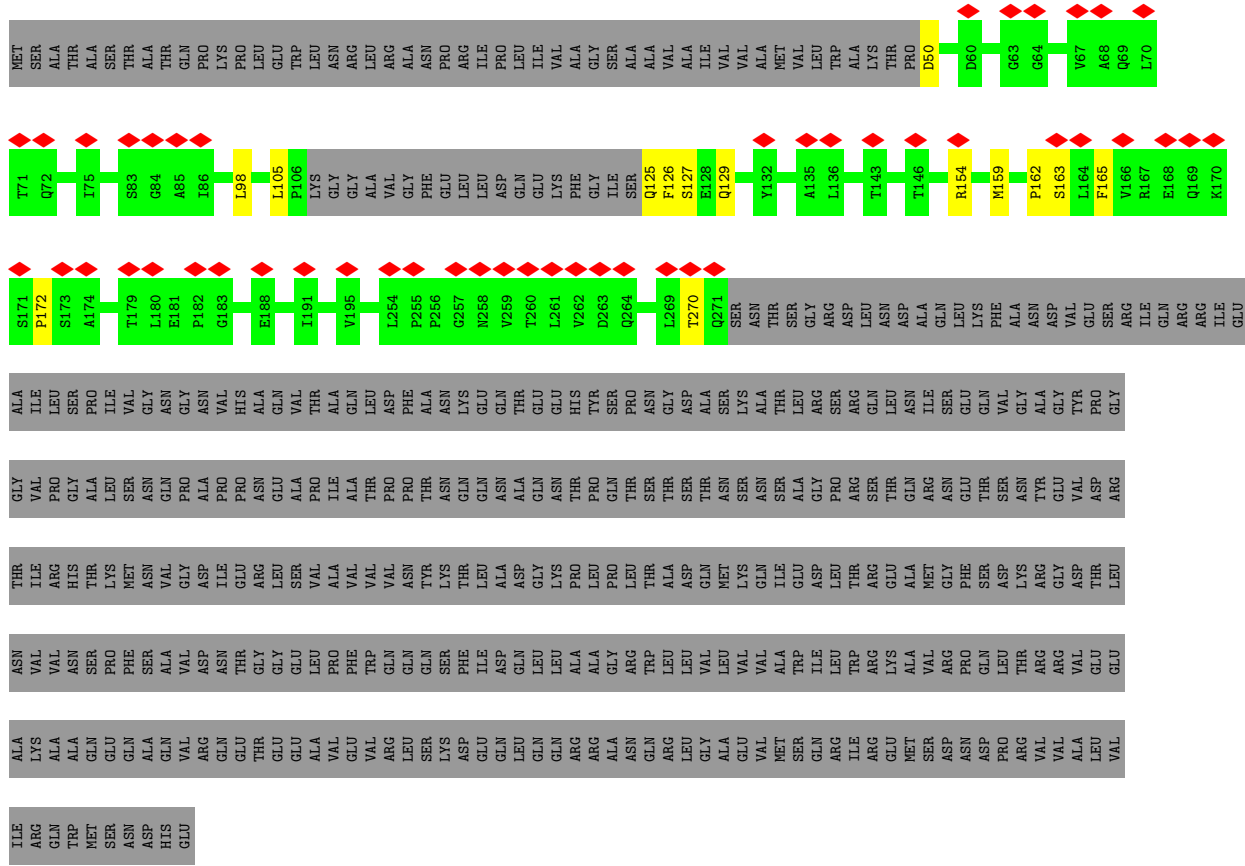

● Molecule 6: Flagellar M-ring protein

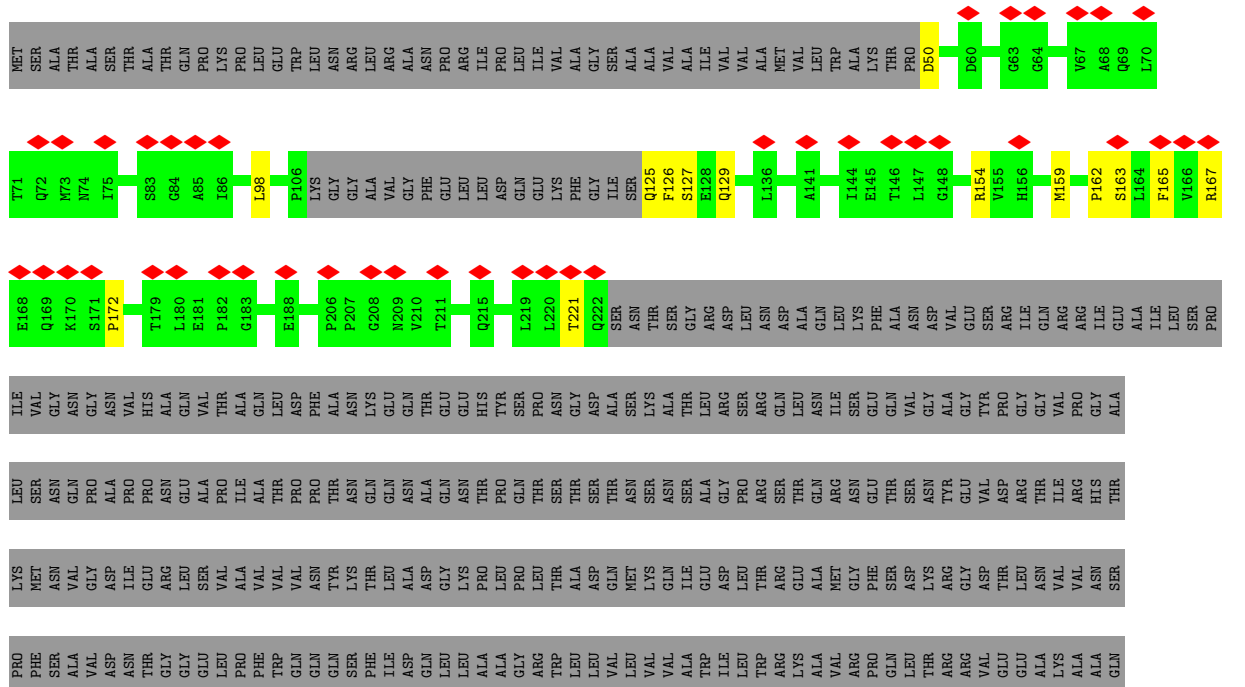

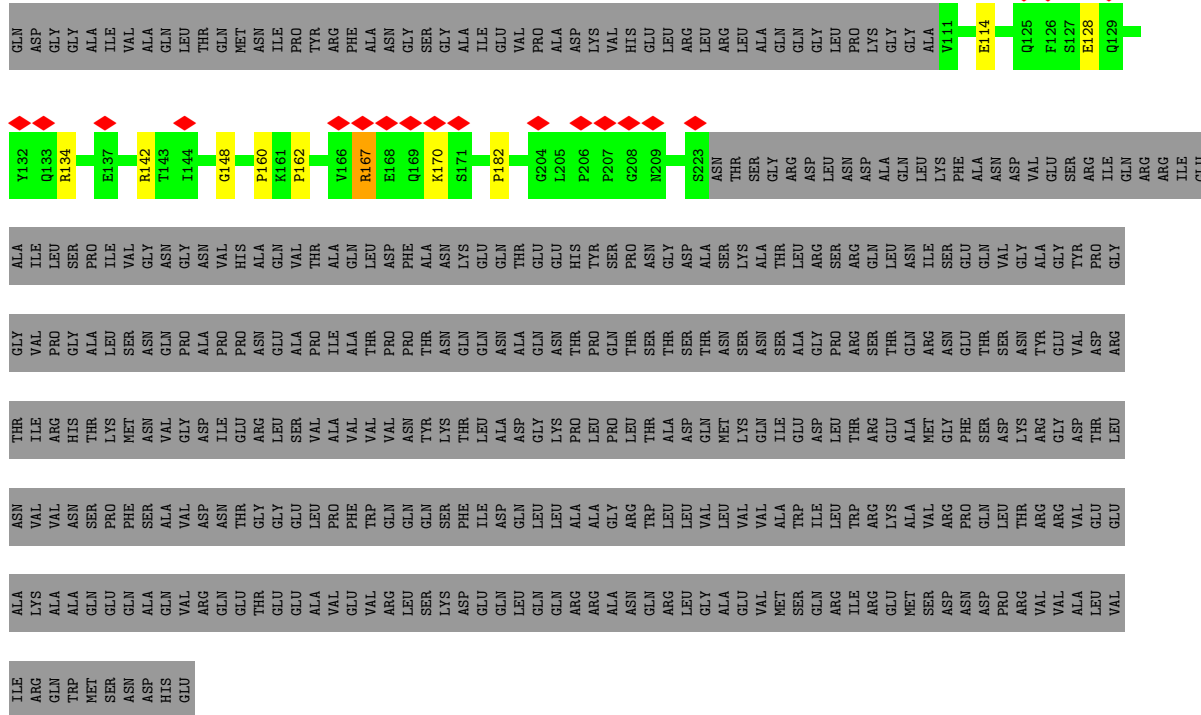

● Molecule 6: Flagellar M-ring protein

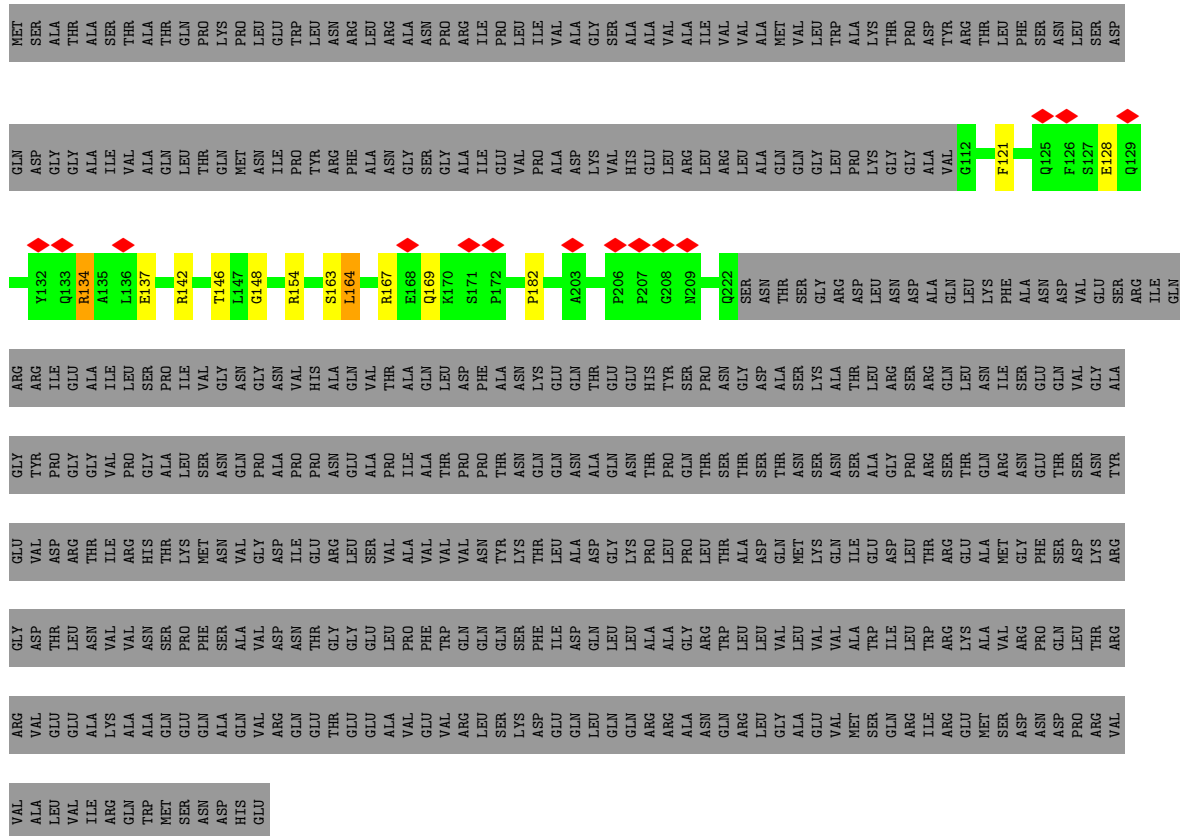

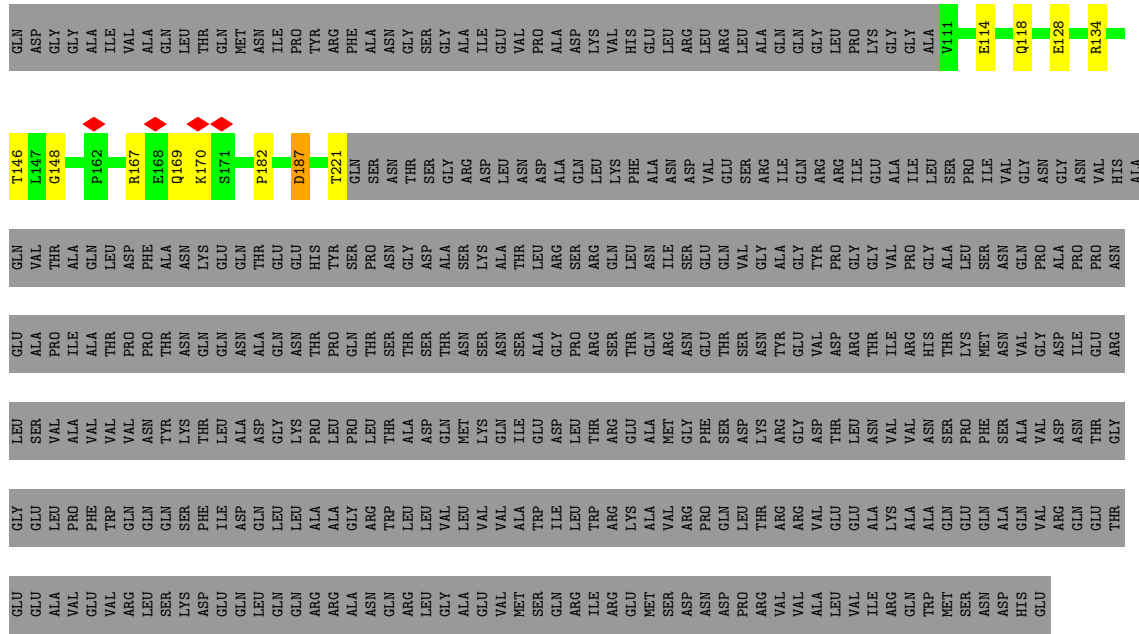

● Molecule 6: Flagellar M-ring protein

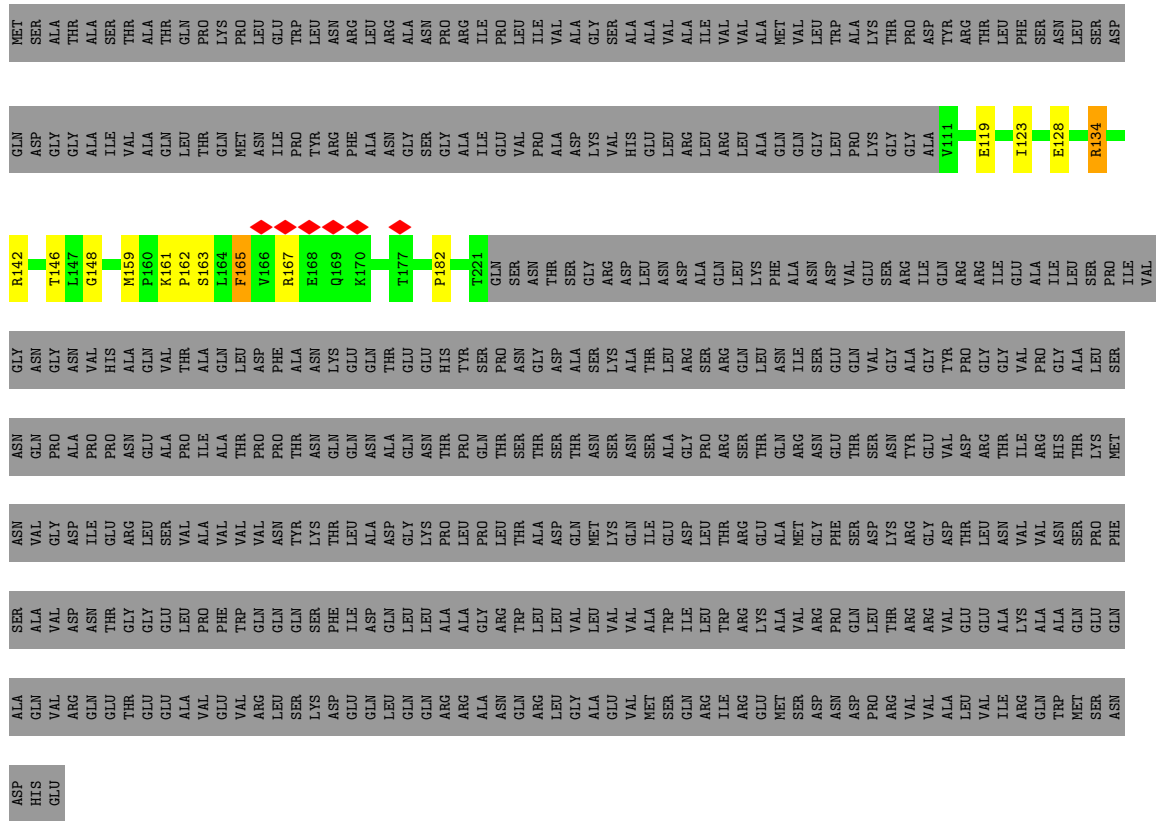

● Molecule 6: Flagellar M-ring protein





• Molecule 6: Flagellar M-ring protein

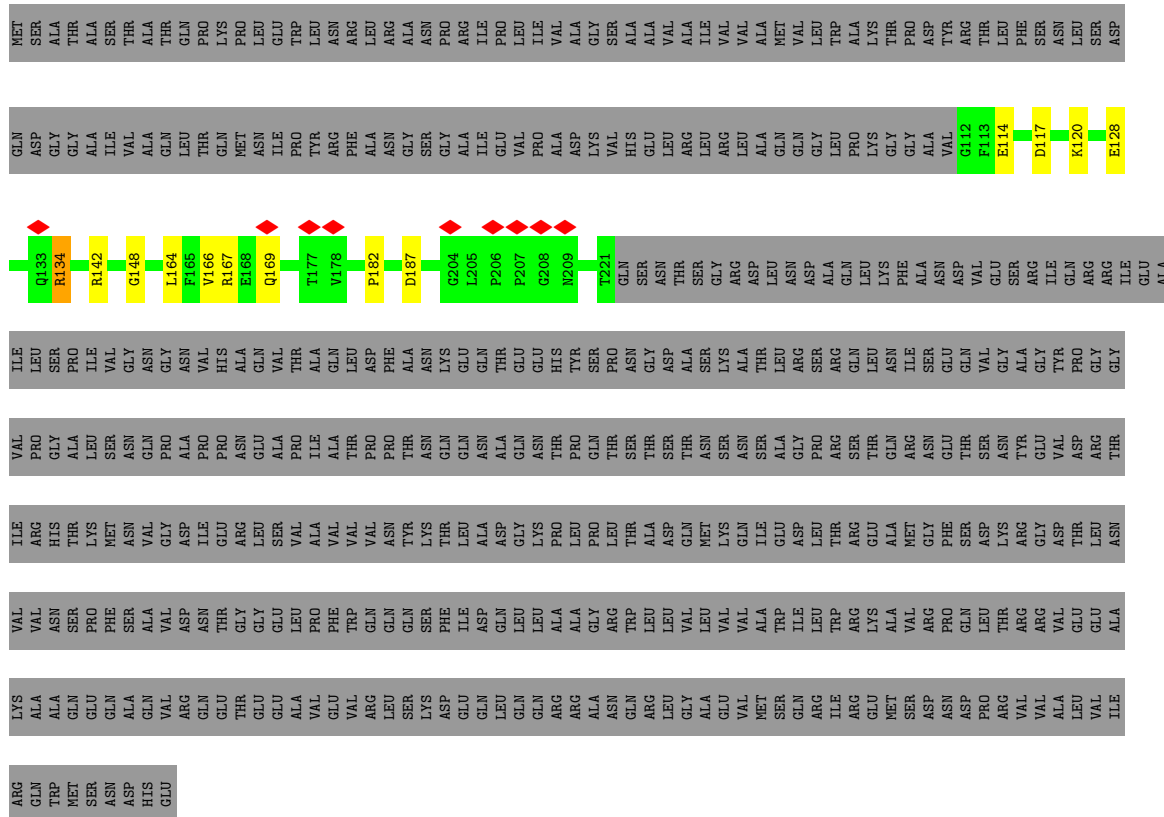



• Molecule 9: Flagellar biosynthetic protein FliP

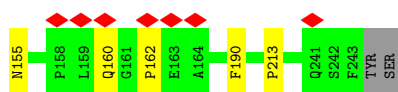
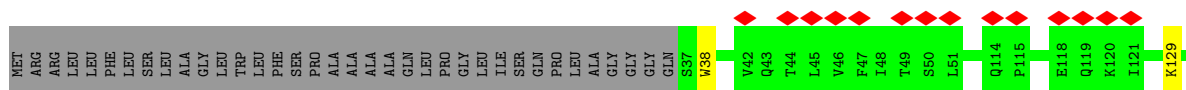
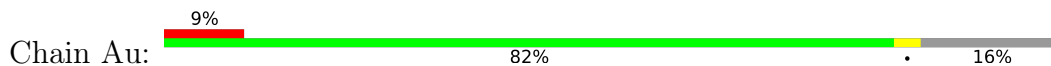

• Molecule 9: Flagellar biosynthetic protein FliP

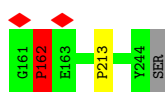
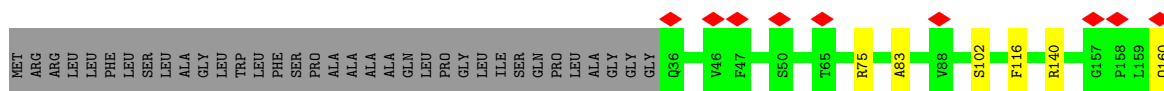
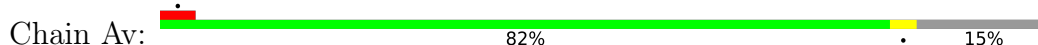

• Molecule 9: Flagellar biosynthetic protein FliP

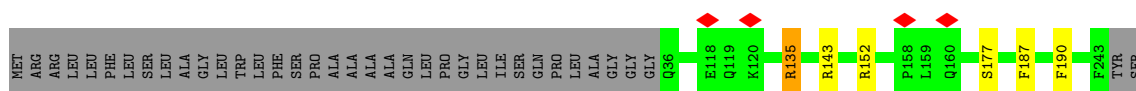
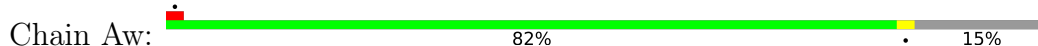

• Molecule 9: Flagellar biosynthetic protein FliP

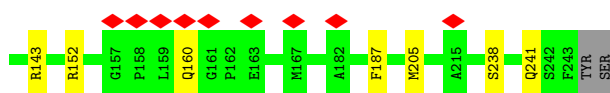
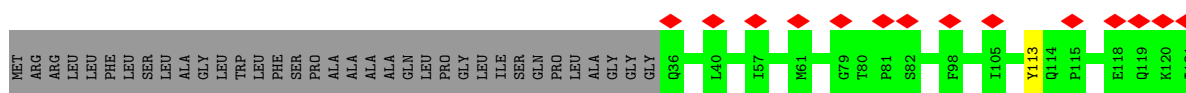
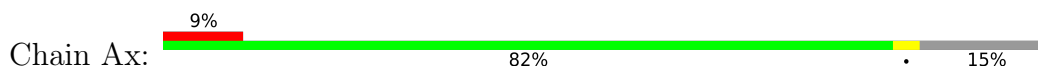

• Molecule 9: Flagellar biosynthetic protein FliP

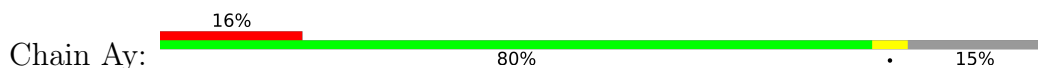

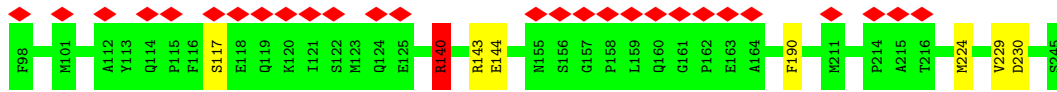
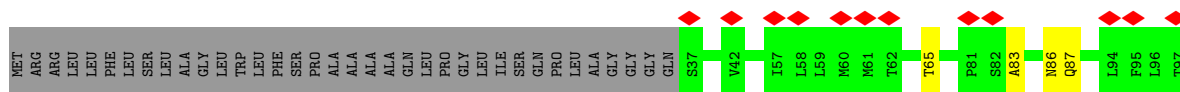

• Molecule 10: Flagellar basal-body rod protein FlgC

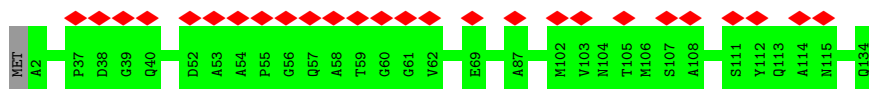

• Molecule 10: Flagellar basal-body rod protein FlgC

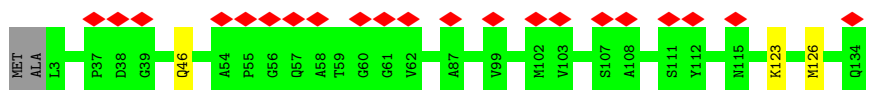

• Molecule 10: Flagellar basal-body rod protein FlgC

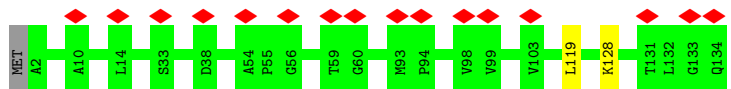

• Molecule 10: Flagellar basal-body rod protein FlgC



• Molecule 10: Flagellar basal-body rod protein FlgC

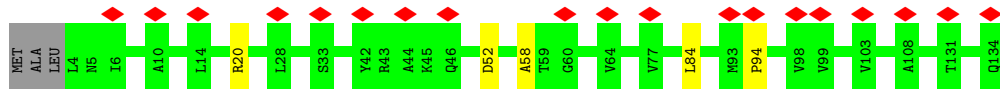

• Molecule 10: Flagellar basal-body rod protein FlgC



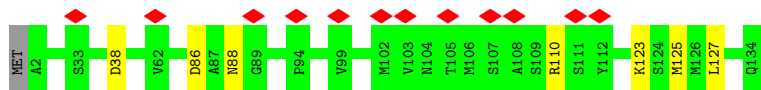

• Molecule 11: Flagellar hook protein FlgE

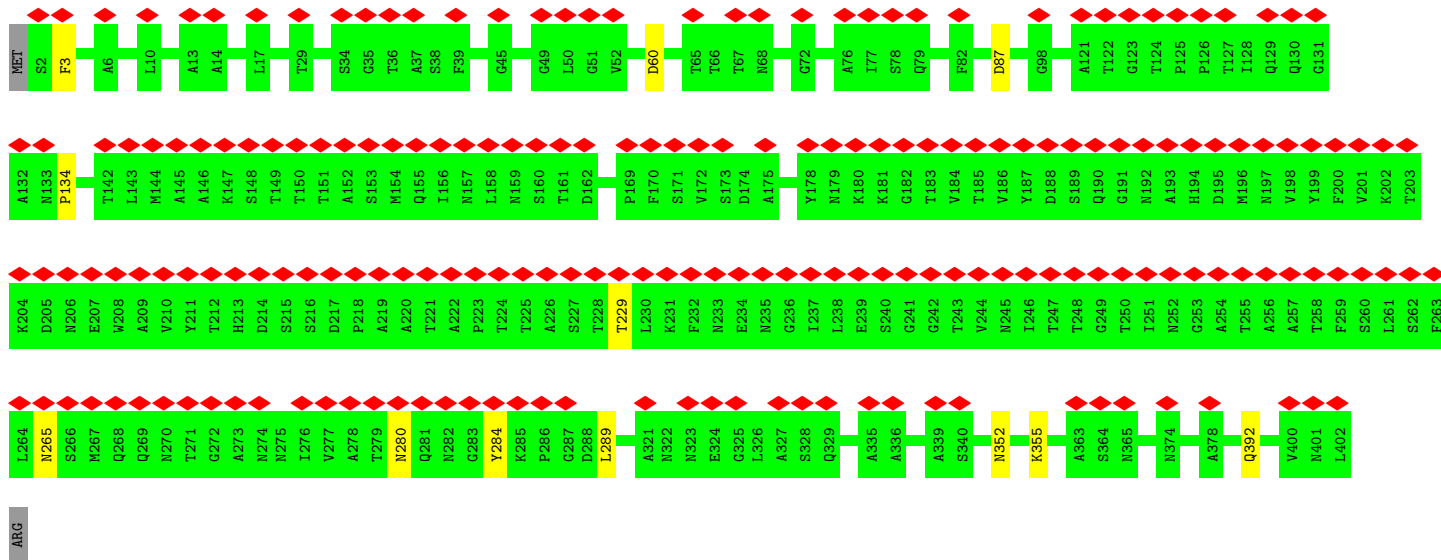

• Molecule 11: Flagellar hook protein FlgE

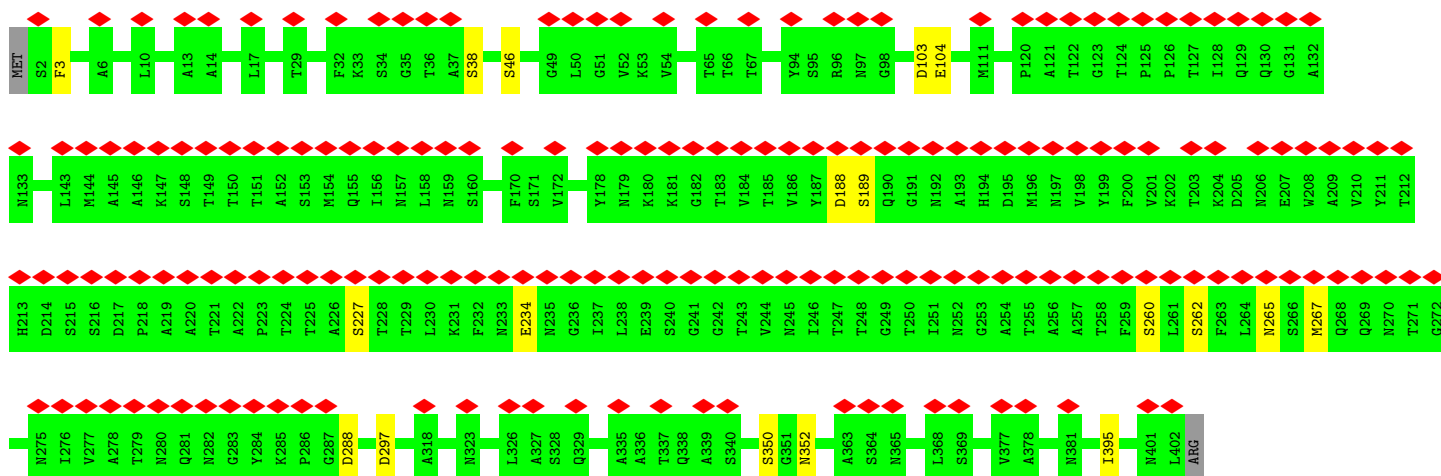

• Molecule 11: Flagellar hook protein FlgE

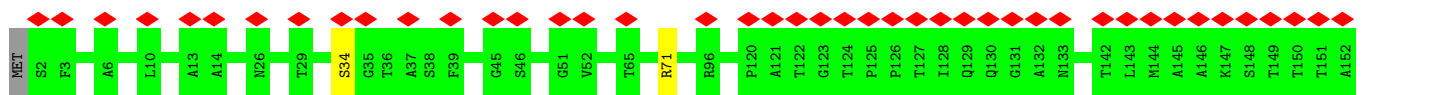
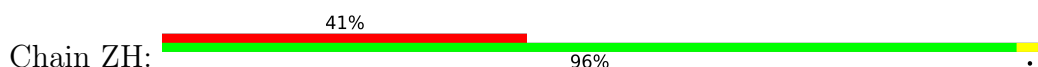

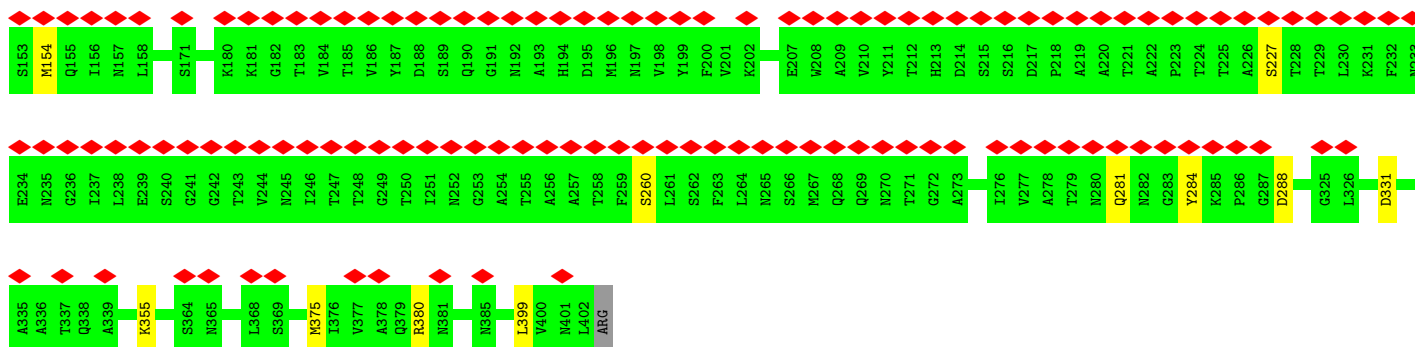

- Molecule 11: Flagellar hook protein FlgE

Chain ZI:

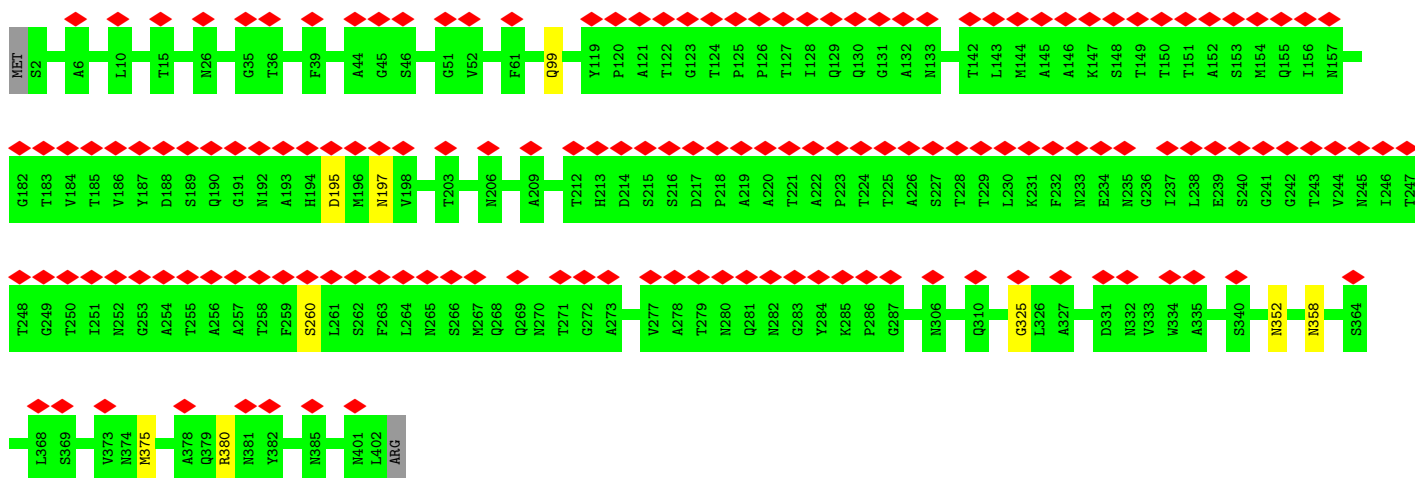

- Molecule 11: Flagellar hook protein FlgE

Chain ZJ:

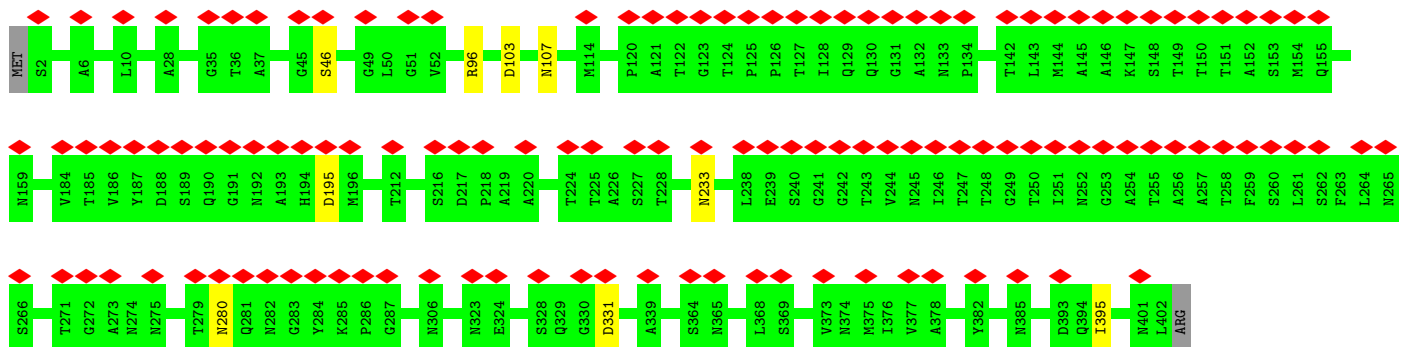

- Molecule 11: Flagellar hook protein FlgE

Chain ZK:

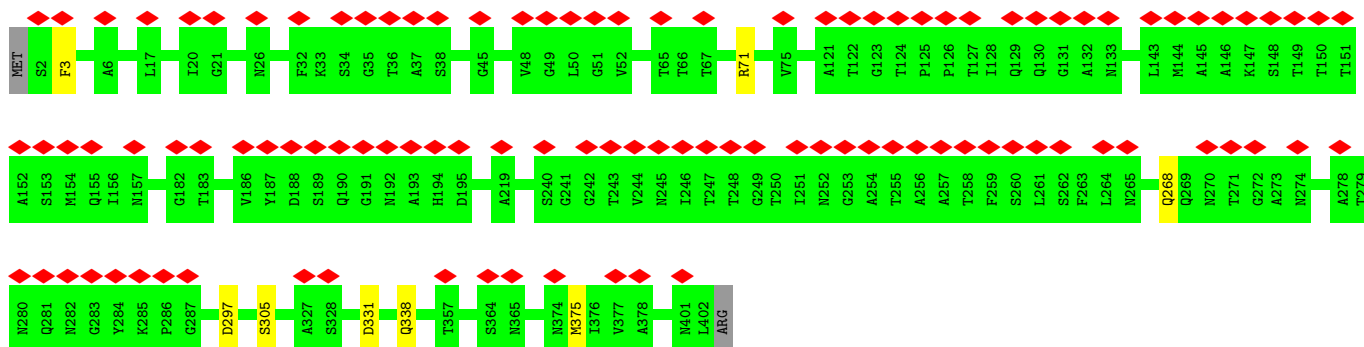

• Molecule 11: Flagellar hook protein FlgE

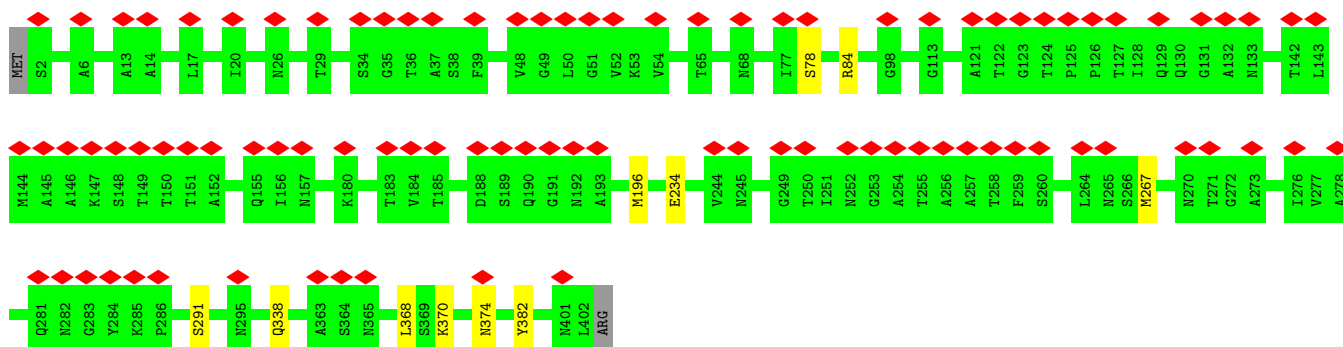

• Molecule 11: Flagellar hook protein FlgE

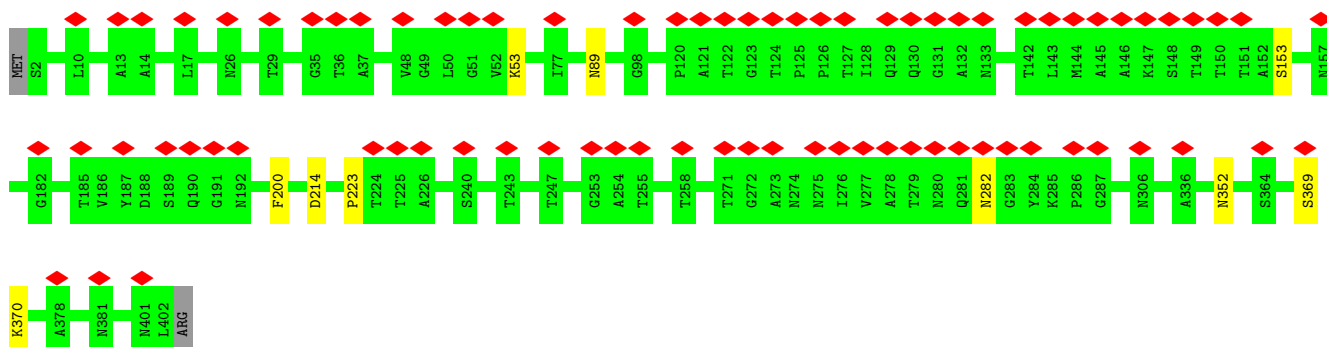

• Molecule 11: Flagellar hook protein FlgE

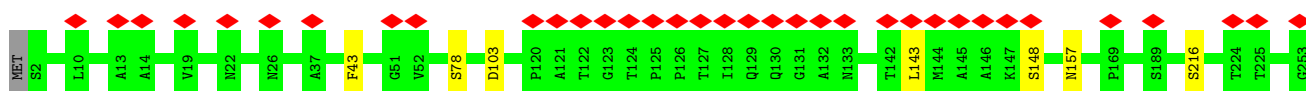

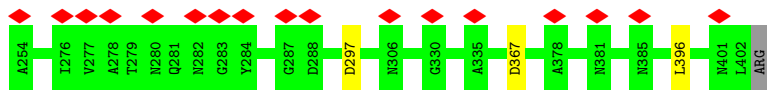

• Molecule 11: Flagellar hook protein FlgE

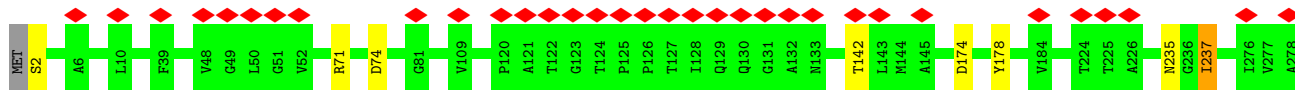

• Molecule 11: Flagellar hook protein FlgE

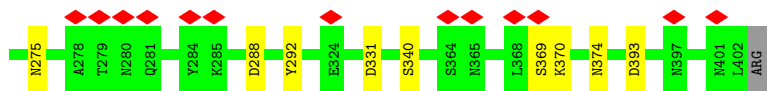
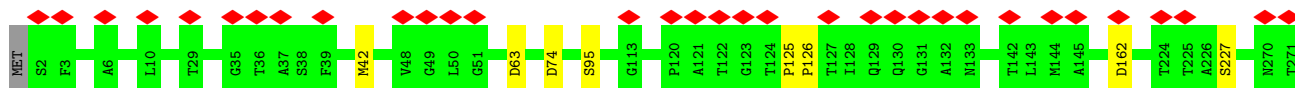

• Molecule 11: Flagellar hook protein FlgE

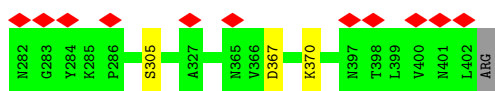
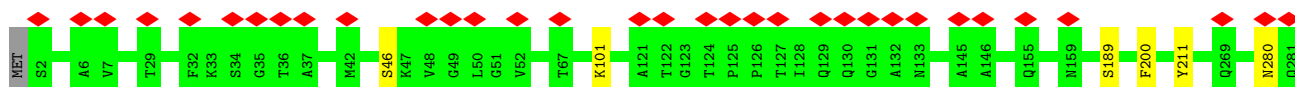

• Molecule 11: Flagellar hook protein FlgE

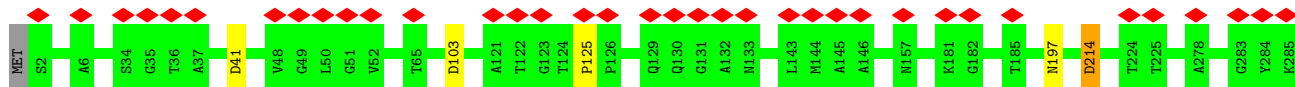

• Molecule 11: Flagellar hook protein FlgE

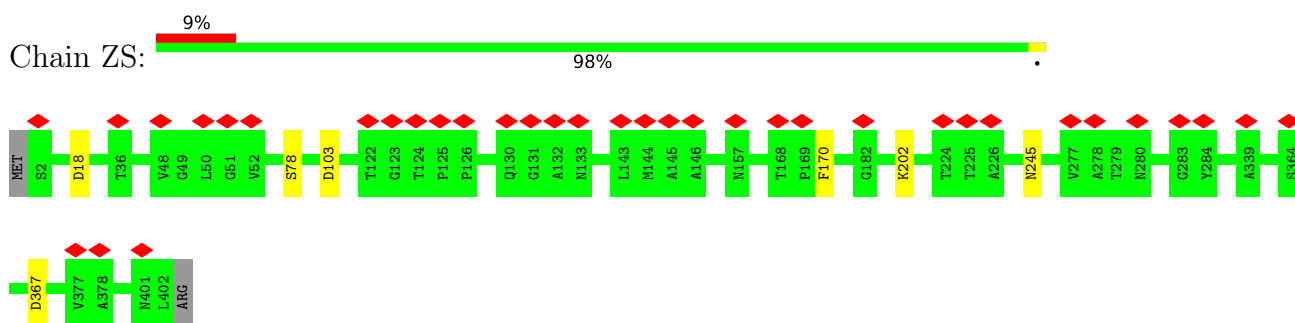

- Molecule 11: Flagellar hook protein FlgE

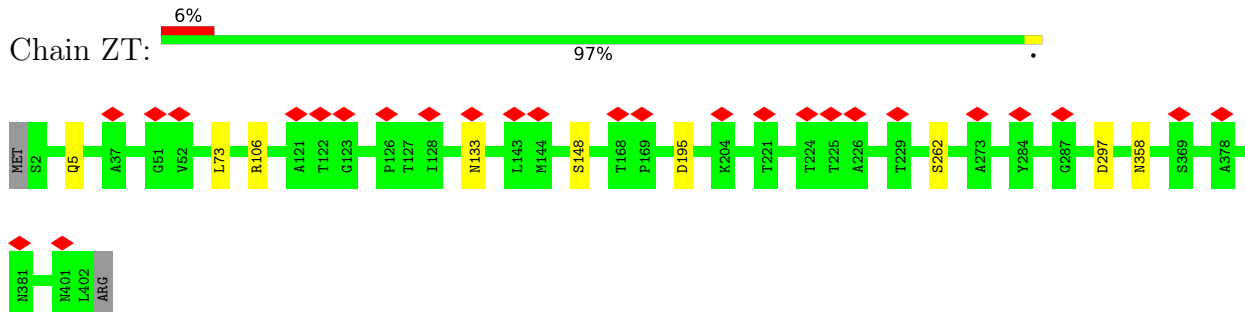

- Molecule 11: Flagellar hook protein FlgE

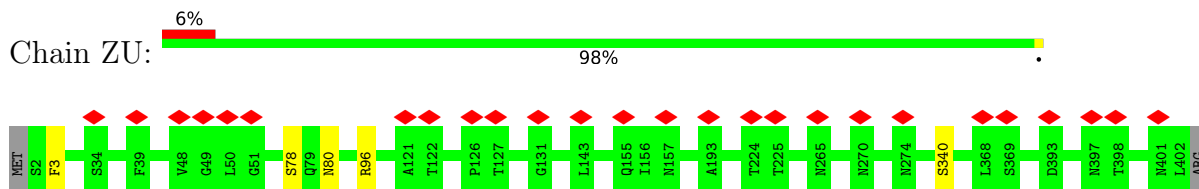

- Molecule 11: Flagellar hook protein FlgE

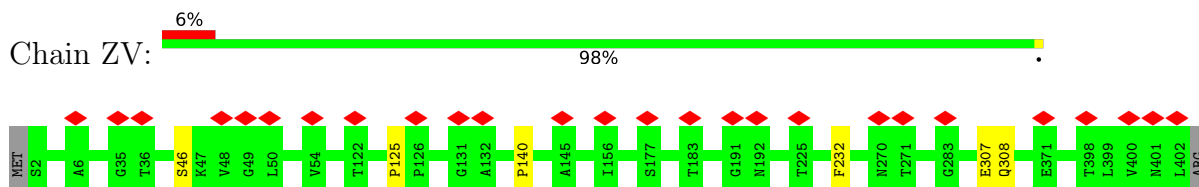

- Molecule 11: Flagellar hook protein FlgE

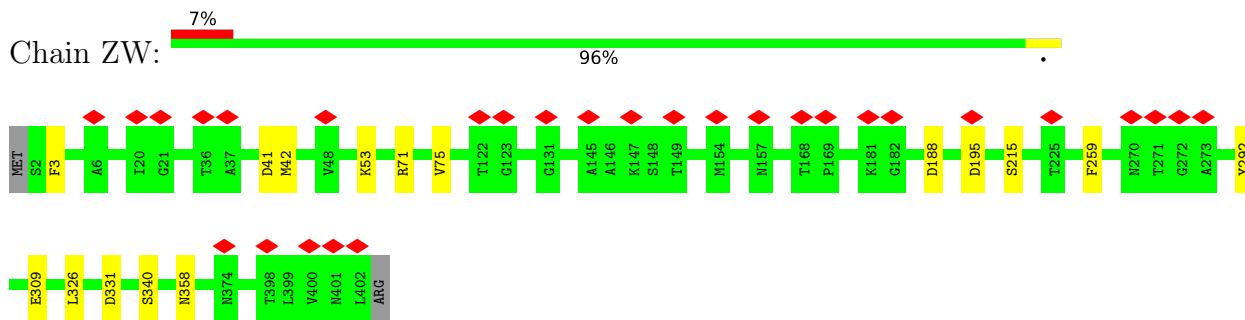

- Molecule 11: Flagellar hook protein FlgE



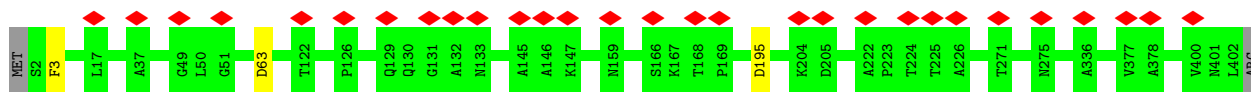

• Molecule 11: Flagellar hook protein FlgE



Chain ZY:

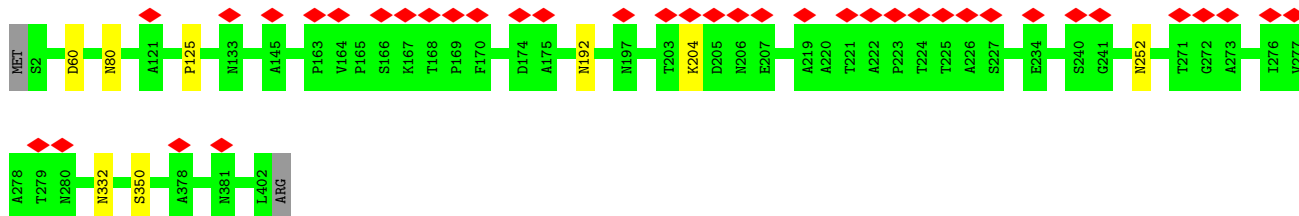

• Molecule 11: Flagellar hook protein FlgE



Chain ZZ:

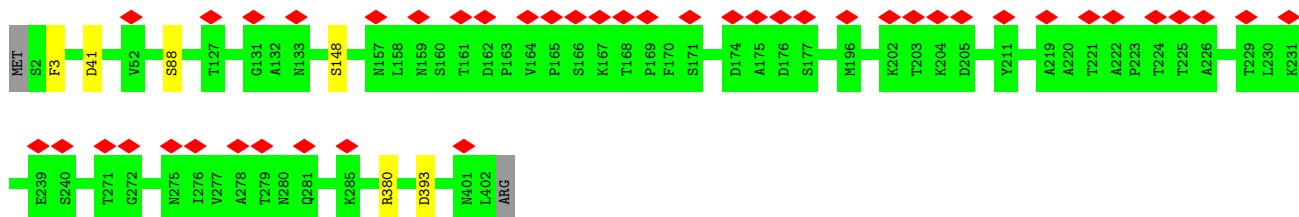

• Molecule 11: Flagellar hook protein FlgE



Chain Za:

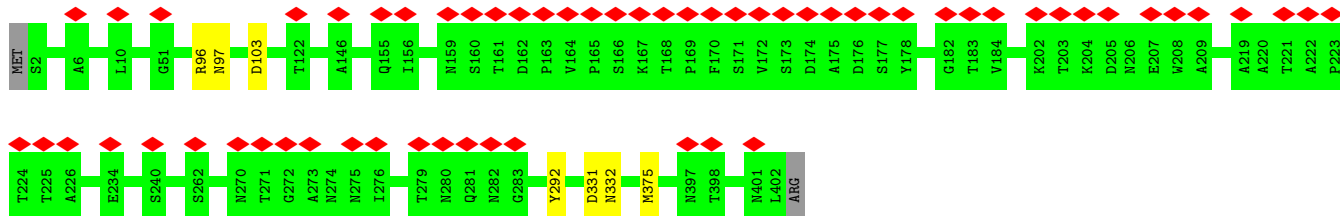

• Molecule 11: Flagellar hook protein FlgE



Chain Zb:



• Molecule 11: Flagellar hook protein FlgE

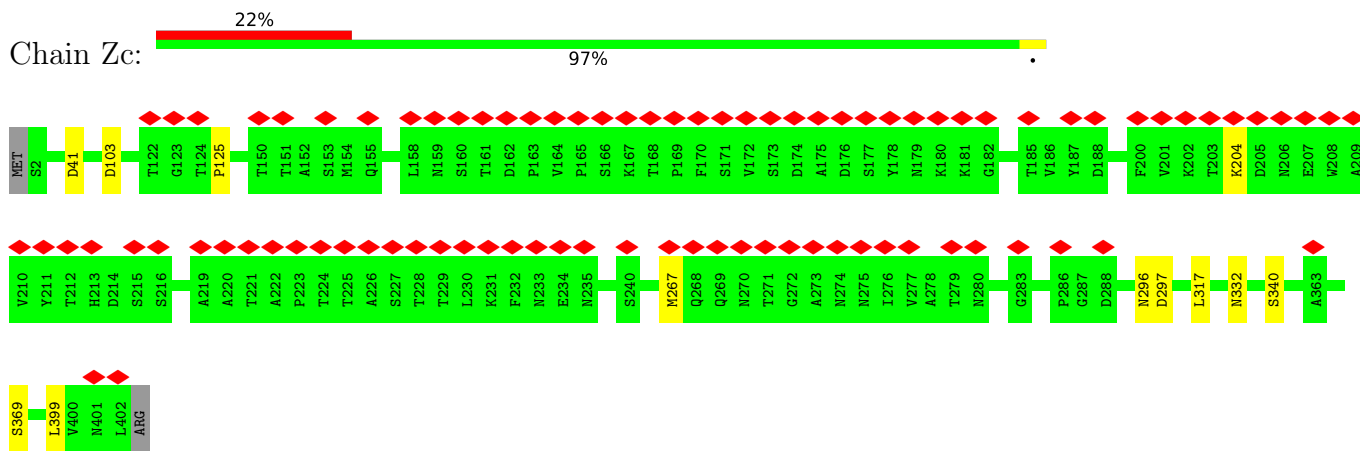

• Molecule 11: Flagellar hook protein FlgE

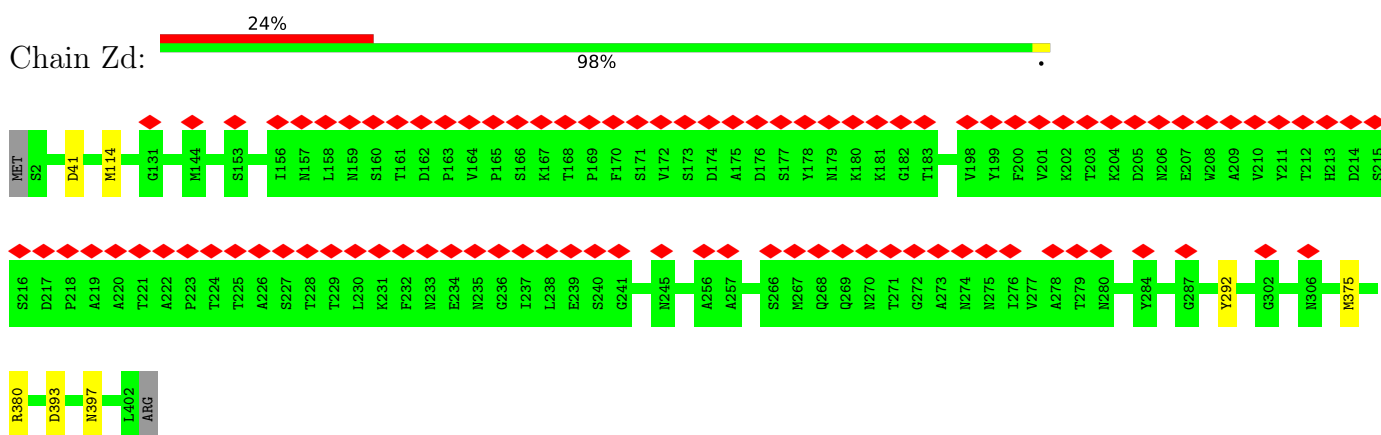

• Molecule 11: Flagellar hook protein FlgE

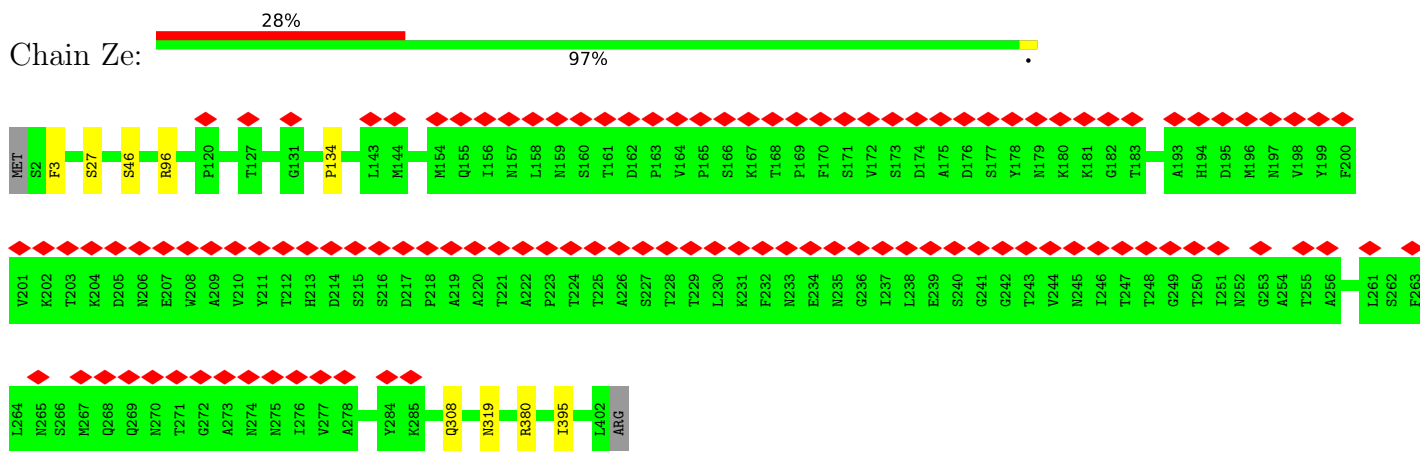

• Molecule 11: Flagellar hook protein FlgE

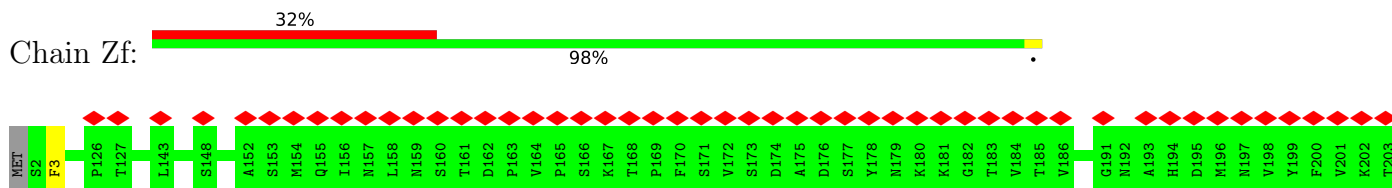

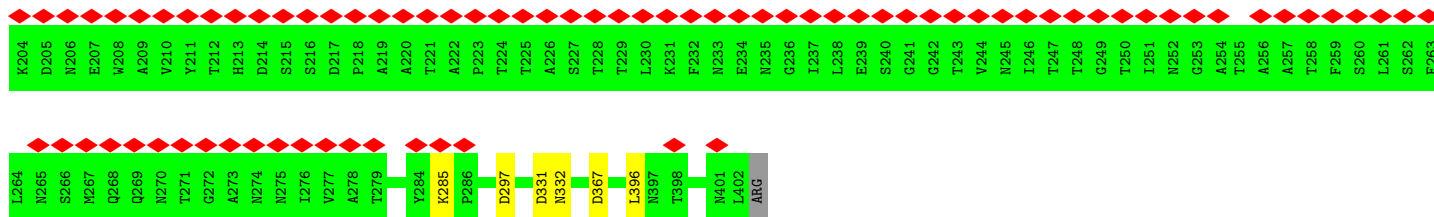

• Molecule 11: Flagellar hook protein FlgE

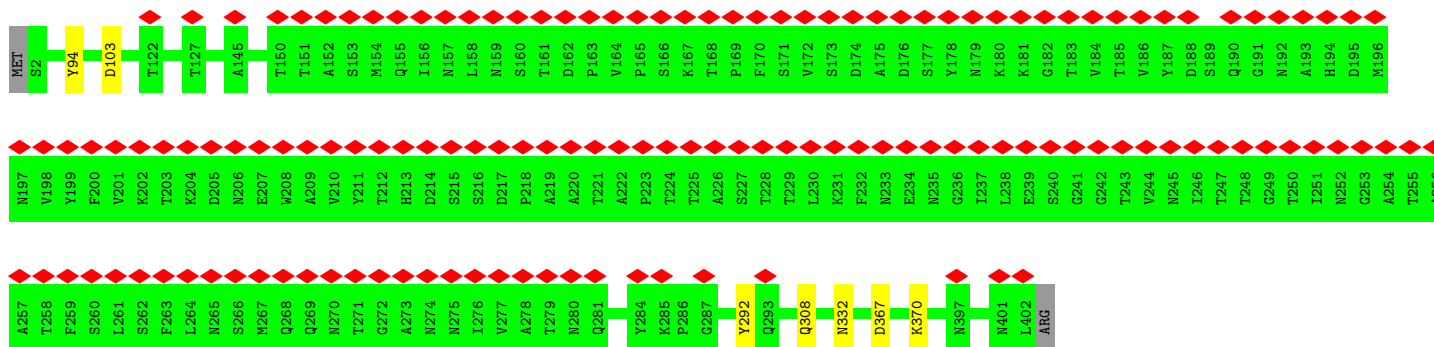

• Molecule 11: Flagellar hook protein FlgE

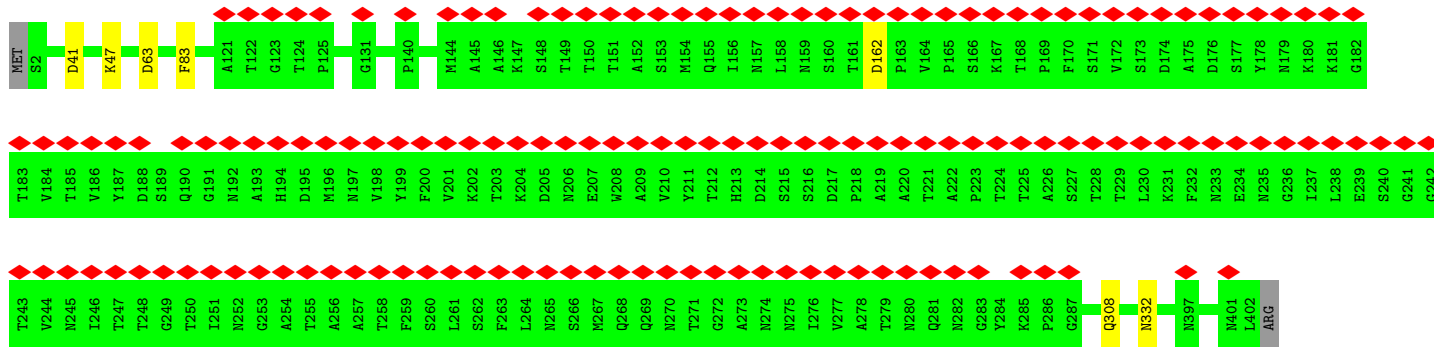
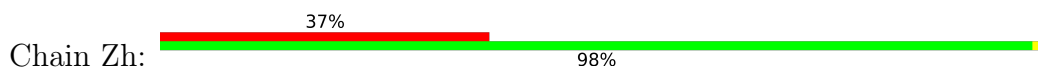

• Molecule 12: Flagellar P-ring protein

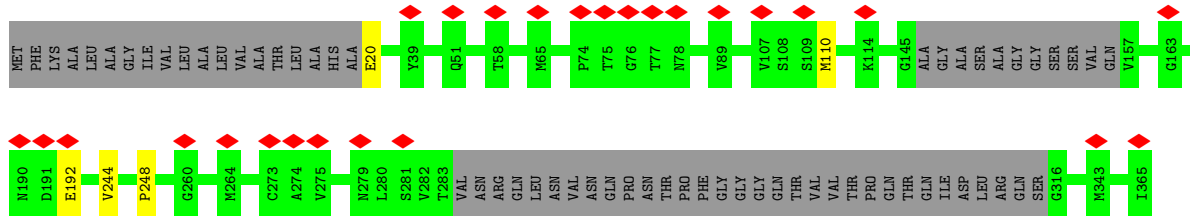
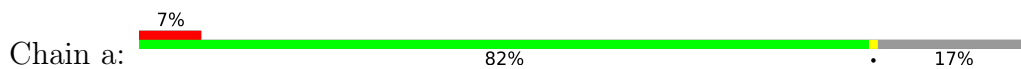

• Molecule 12: Flagellar P-ring protein

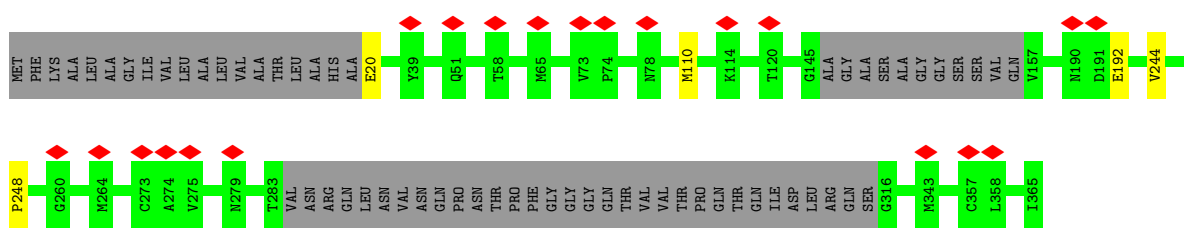
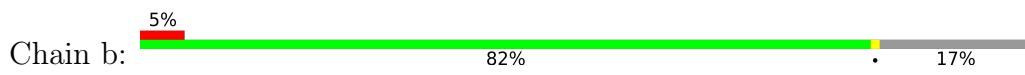

• Molecule 12: Flagellar P-ring protein

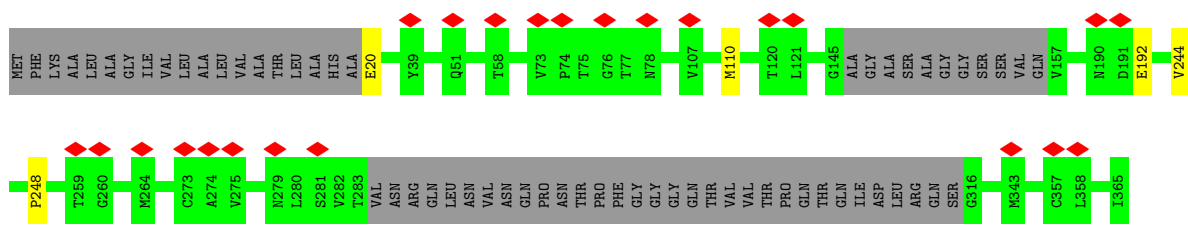
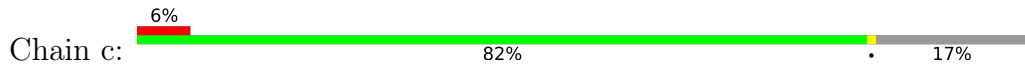

• Molecule 12: Flagellar P-ring protein

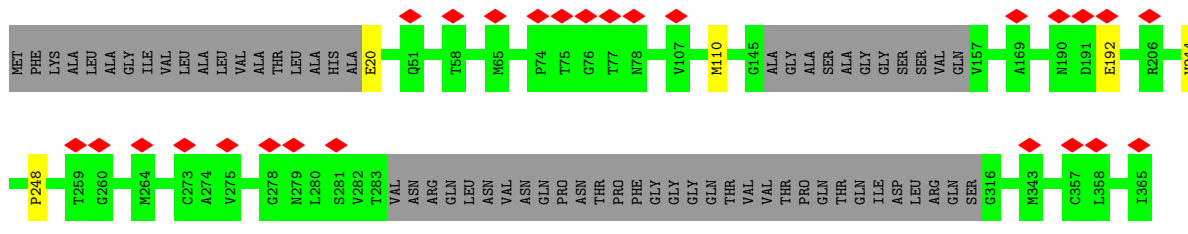
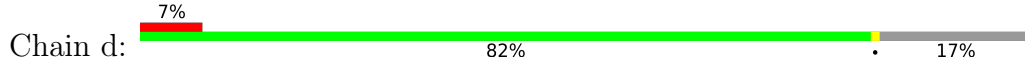

• Molecule 12: Flagellar P-ring protein

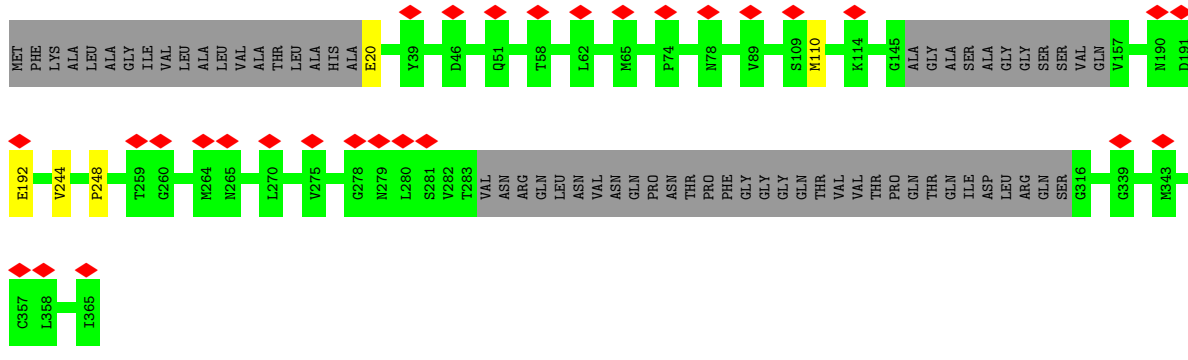
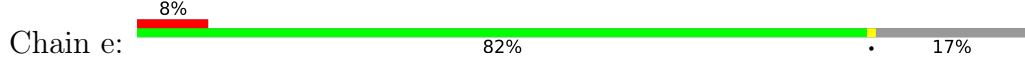

• Molecule 12: Flagellar P-ring protein

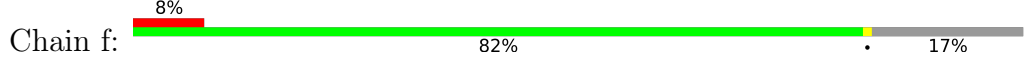

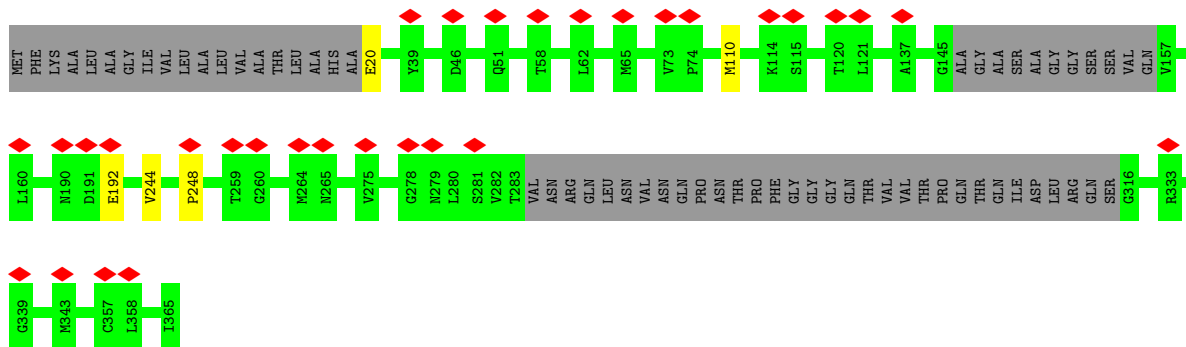

• Molecule 12: Flagellar P-ring protein

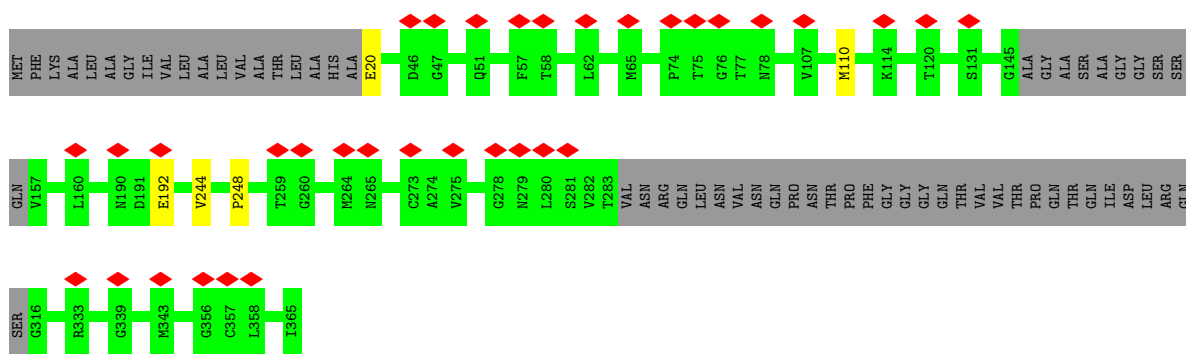
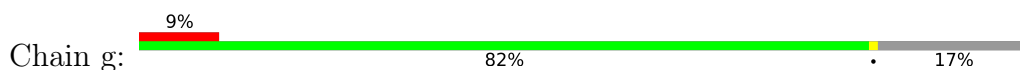

• Molecule 12: Flagellar P-ring protein

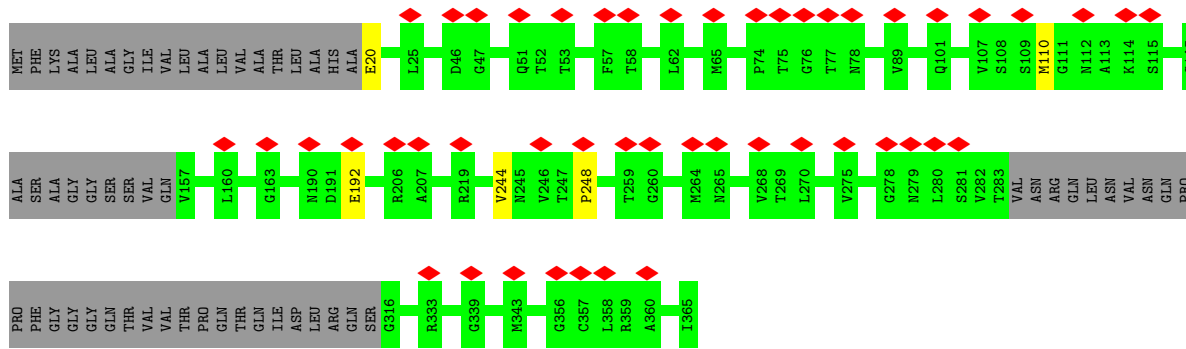
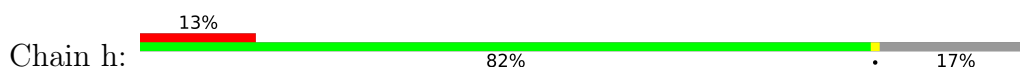

• Molecule 12: Flagellar P-ring protein

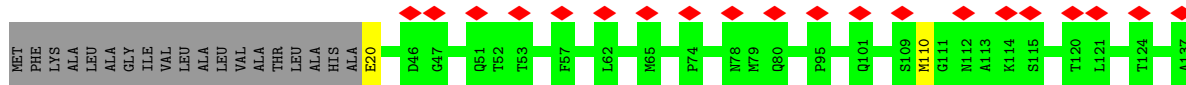
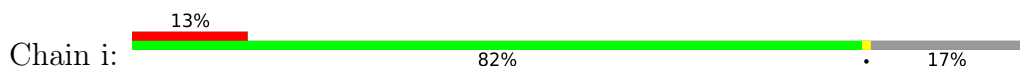

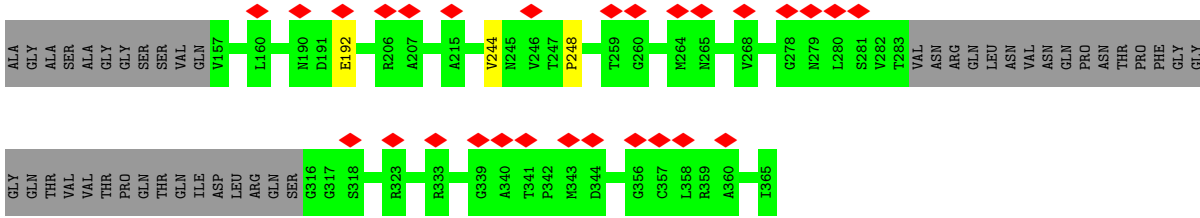

• Molecule 12: Flagellar P-ring protein

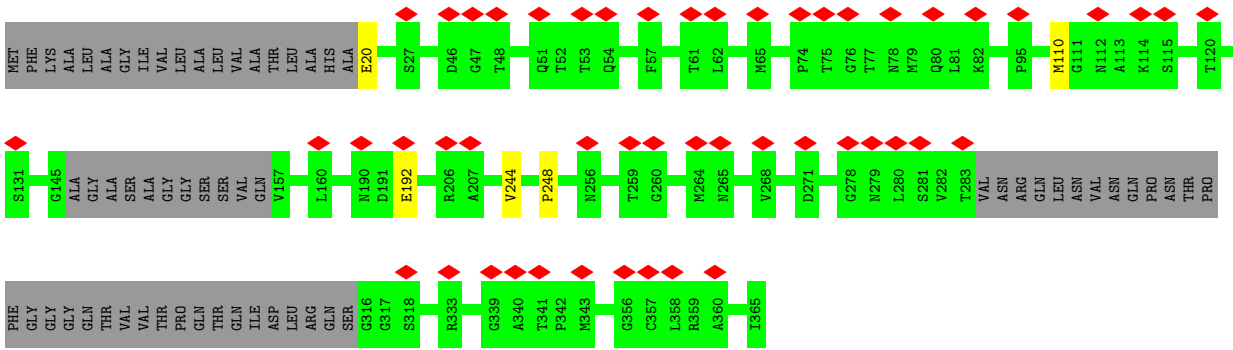
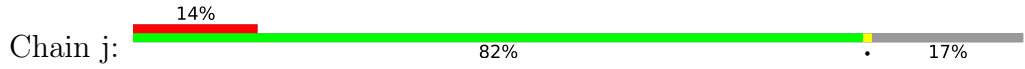

• Molecule 12: Flagellar P-ring protein

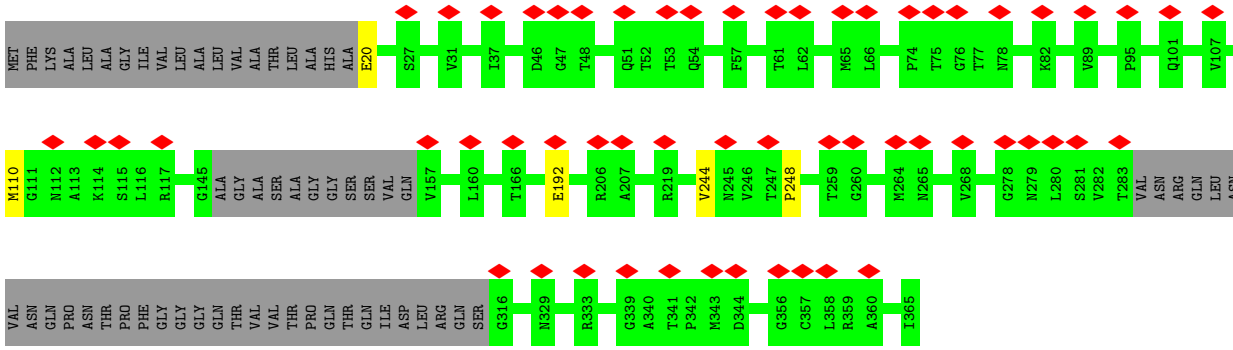
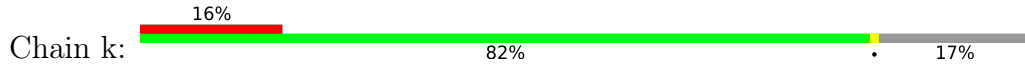

• Molecule 12: Flagellar P-ring protein

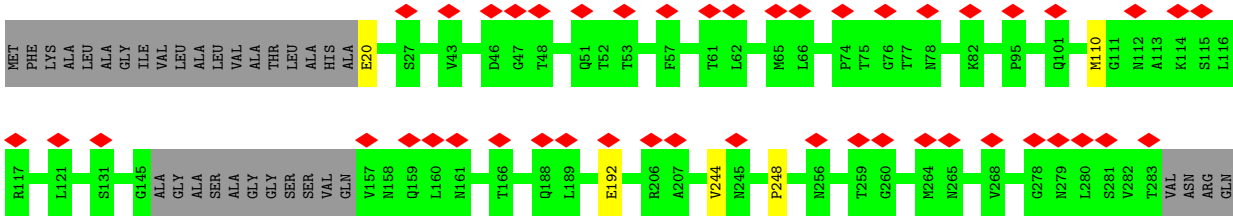
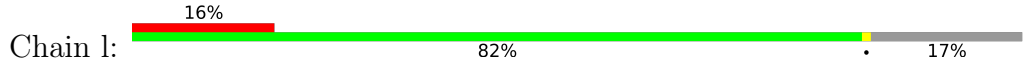

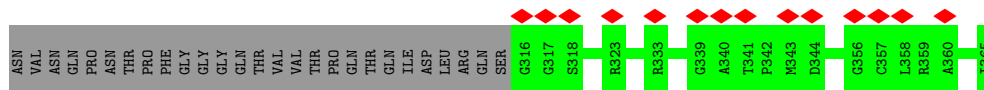

• Molecule 12: Flagellar P-ring protein

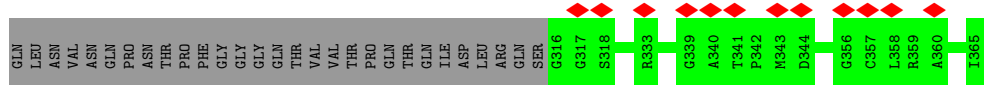
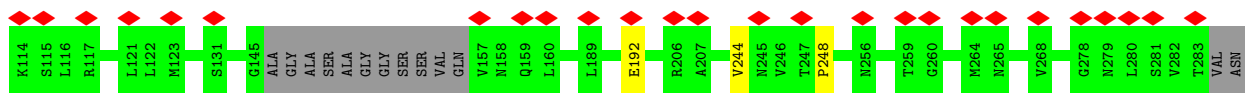
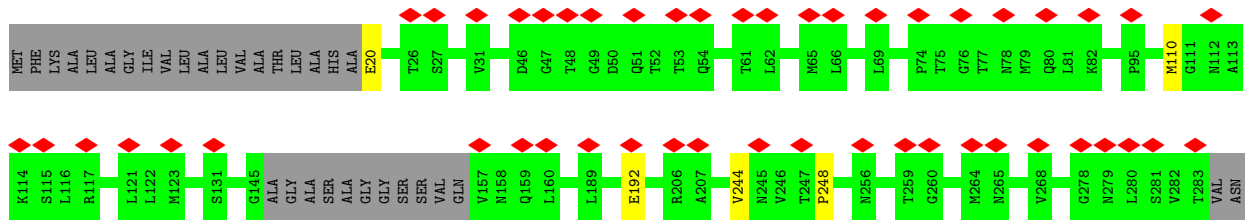
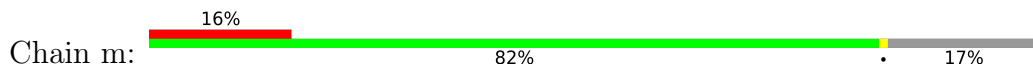

• Molecule 12: Flagellar P-ring protein

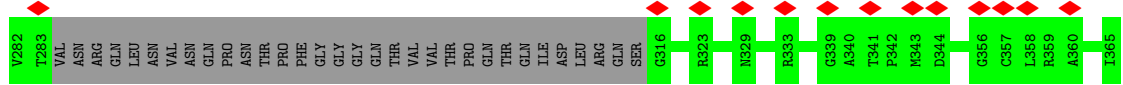
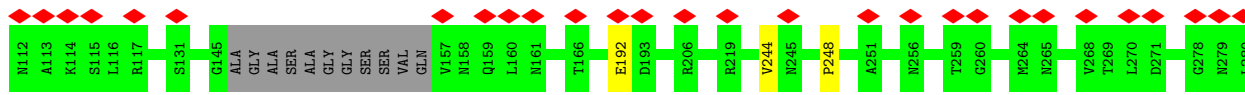
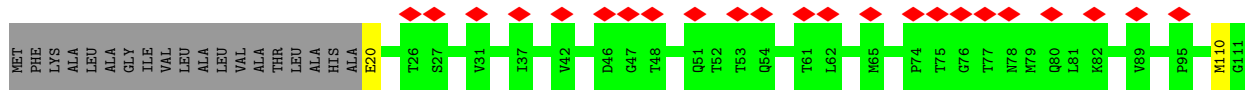
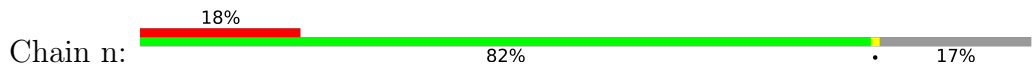

• Molecule 12: Flagellar P-ring protein

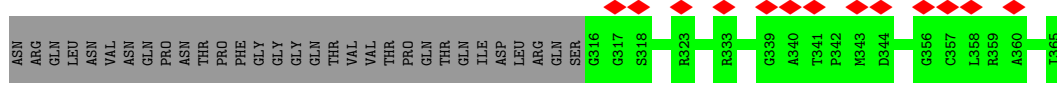
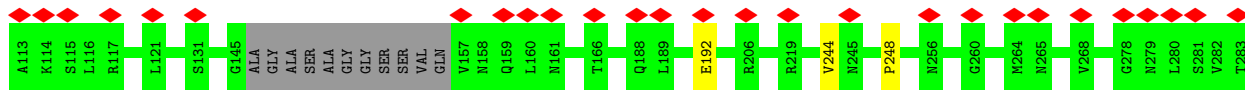
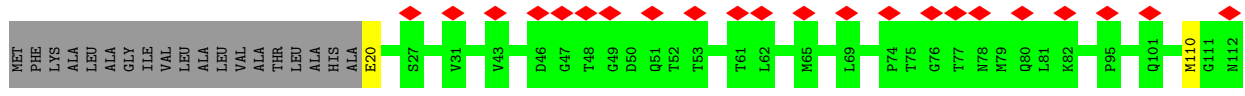
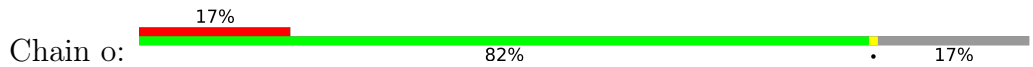

• Molecule 12: Flagellar P-ring protein

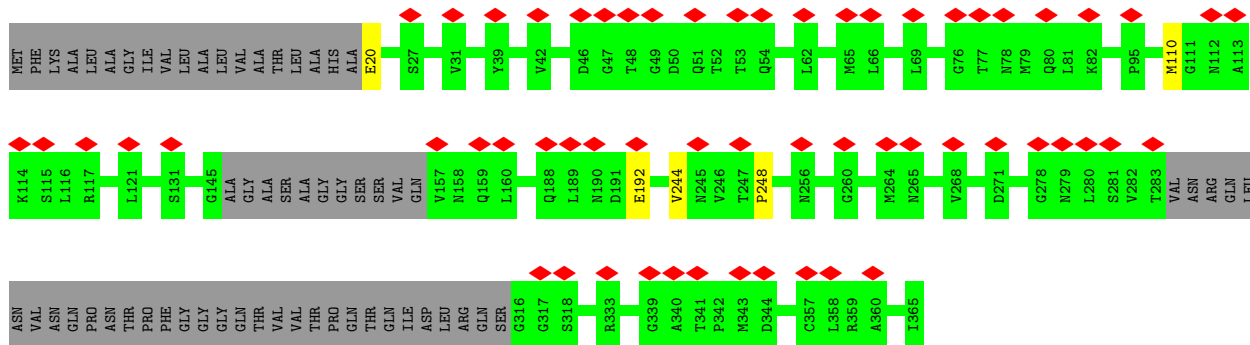
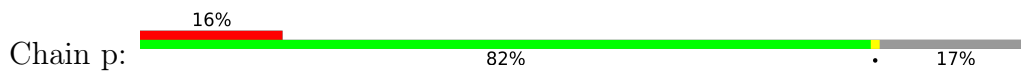

• Molecule 12: Flagellar P-ring protein

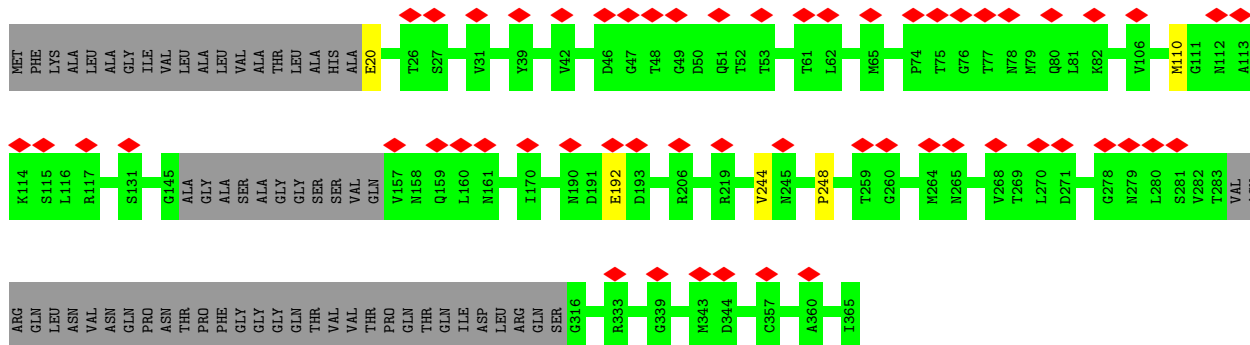
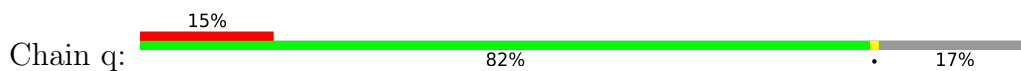

• Molecule 12: Flagellar P-ring protein

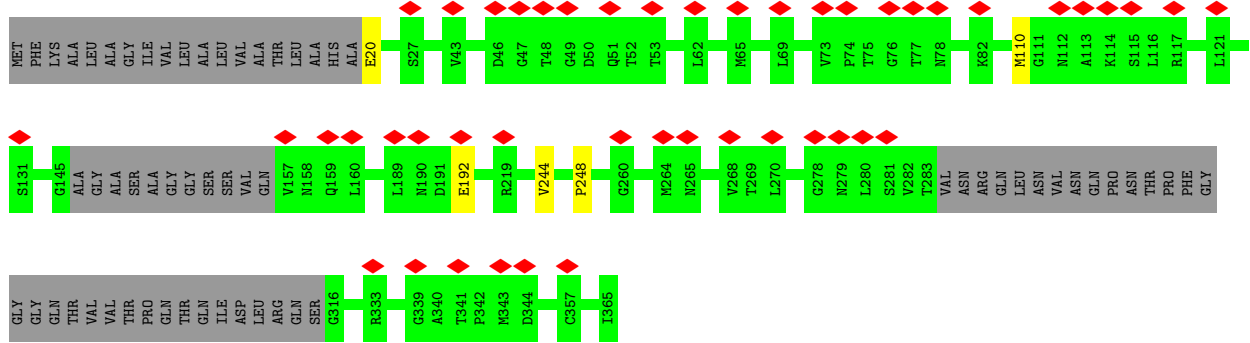
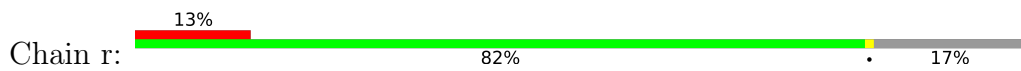

• Molecule 12: Flagellar P-ring protein

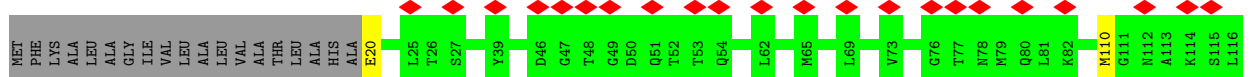
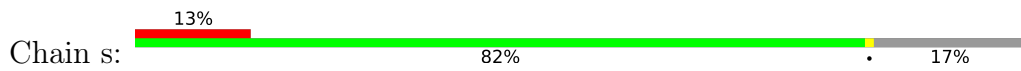

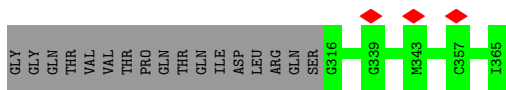

• Molecule 12: Flagellar P-ring protein

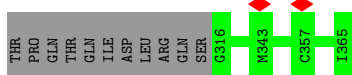
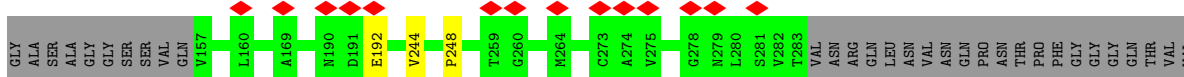
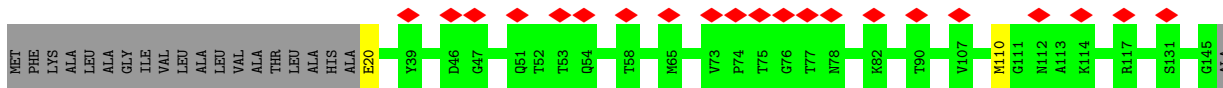
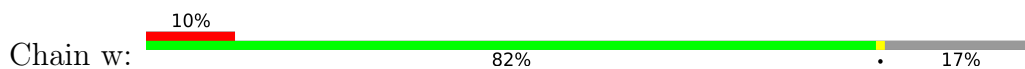

• Molecule 12: Flagellar P-ring protein

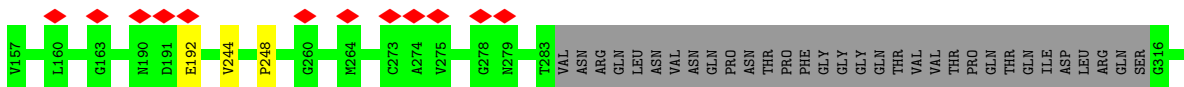
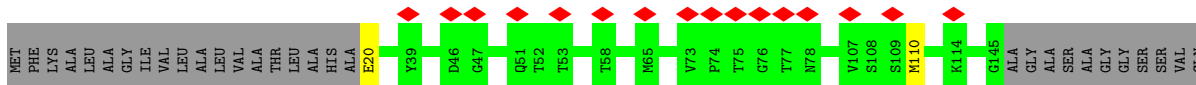
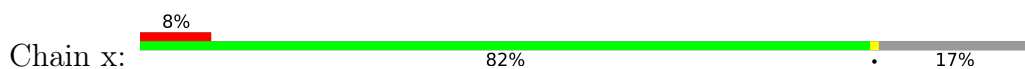

• Molecule 12: Flagellar P-ring protein

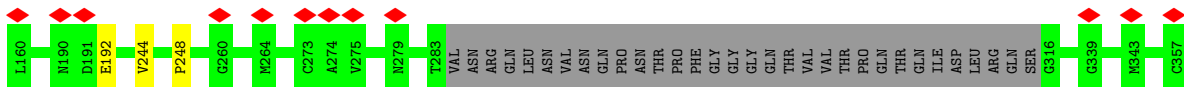
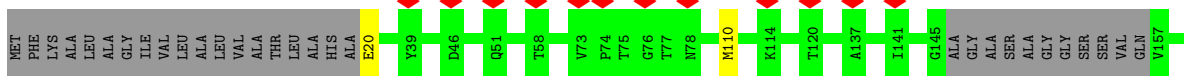
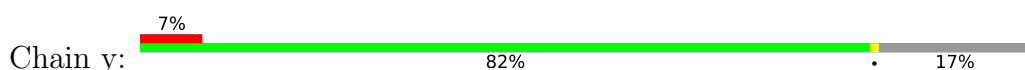

• Molecule 12: Flagellar P-ring protein

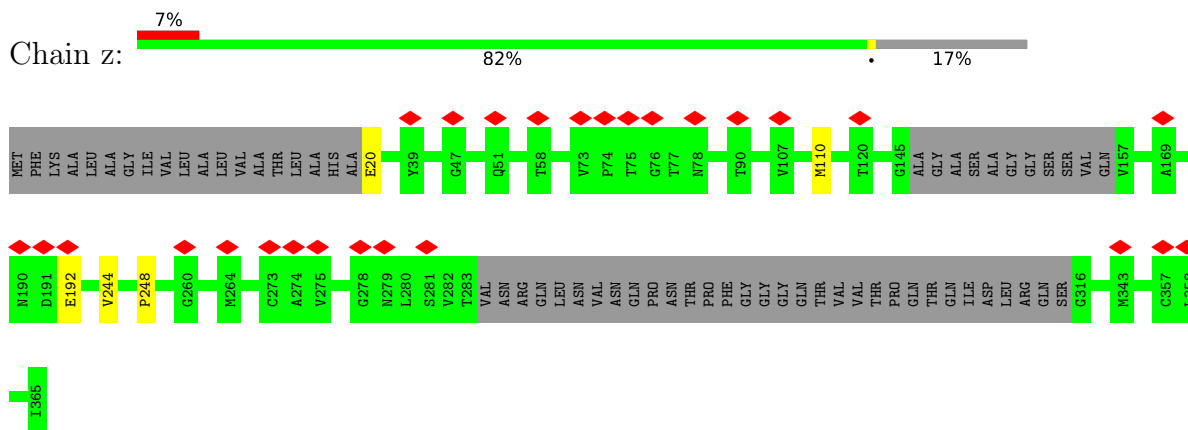

- Molecule 13: Flagellar motor switch protein FliN

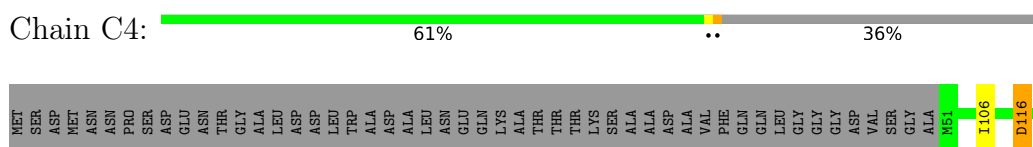

- Molecule 13: Flagellar motor switch protein FliN

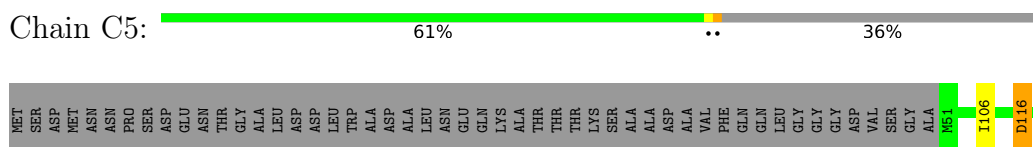

- Molecule 13: Flagellar motor switch protein FliN

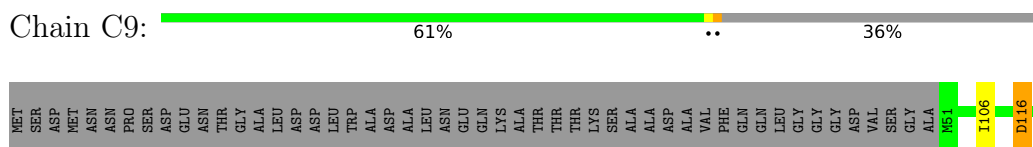

- Molecule 13: Flagellar motor switch protein FliN

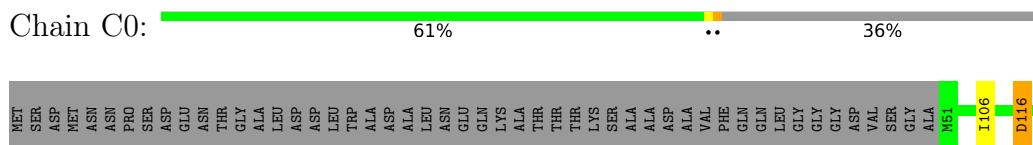

- Molecule 13: Flagellar motor switch protein FliN

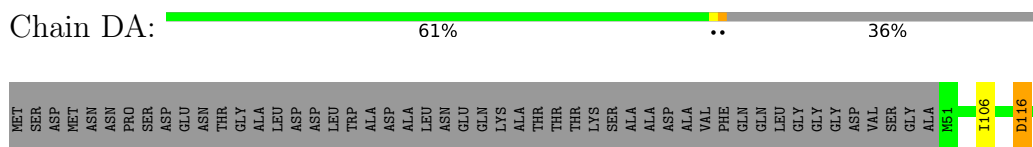

- Molecule 13: Flagellar motor switch protein FliN

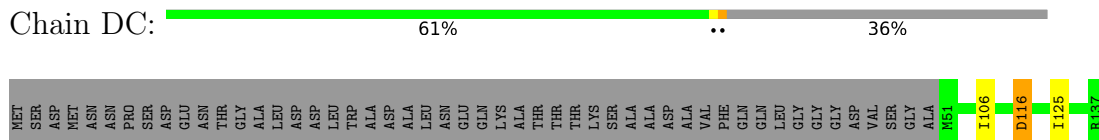

● Molecule 13: Flagellar motor switch protein FliN

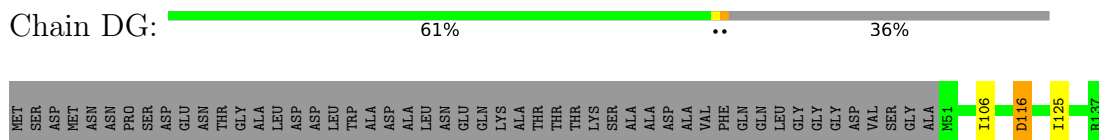

● Molecule 13: Flagellar motor switch protein FliN

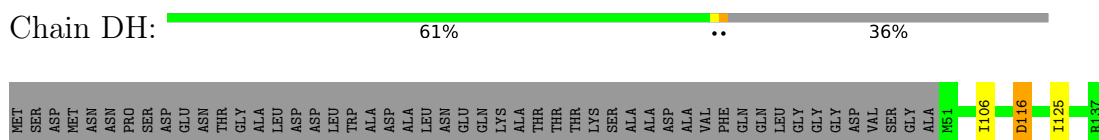

● Molecule 13: Flagellar motor switch protein FliN

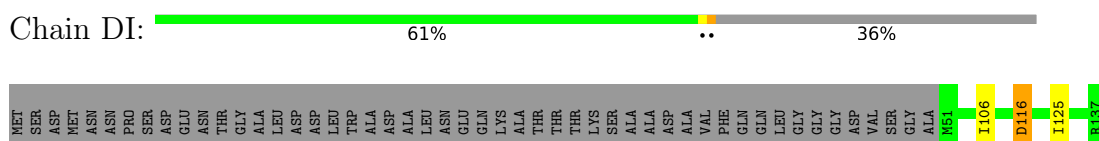

● Molecule 13: Flagellar motor switch protein FliN

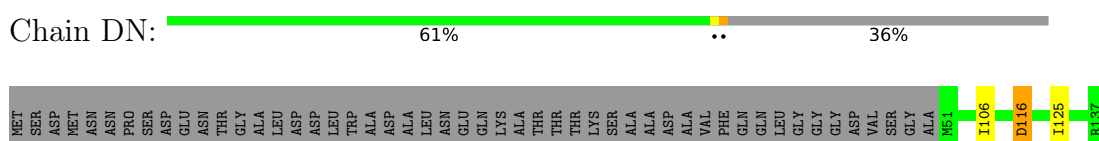

● Molecule 13: Flagellar motor switch protein FliN

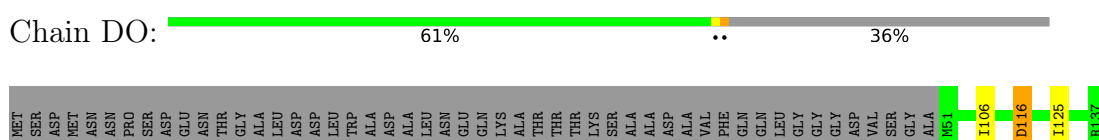

● Molecule 13: Flagellar motor switch protein FliN

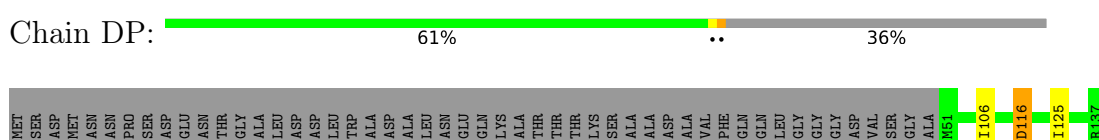

● Molecule 13: Flagellar motor switch protein FliN

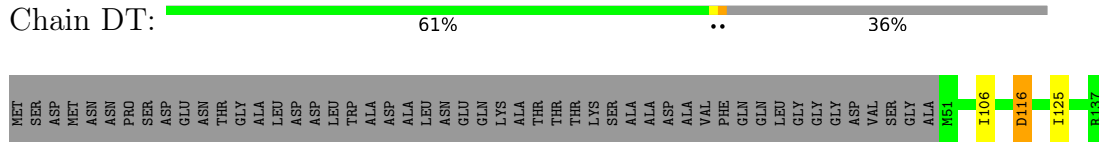

- Molecule 13: Flagellar motor switch protein FlIN

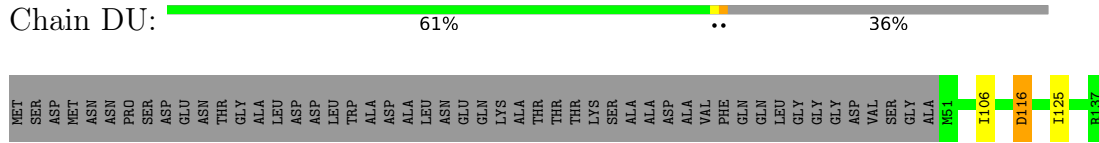

- Molecule 13: Flagellar motor switch protein FlIN

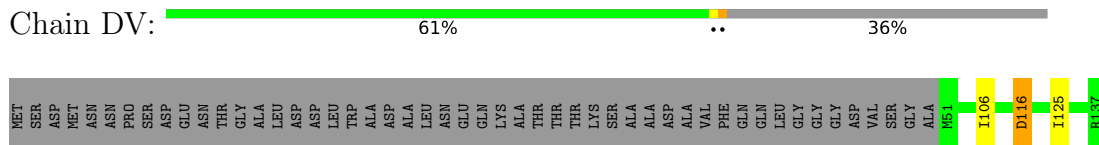

- Molecule 13: Flagellar motor switch protein FlIN

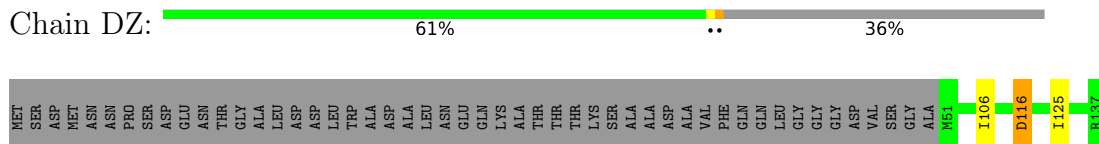

- Molecule 13: Flagellar motor switch protein FlIN

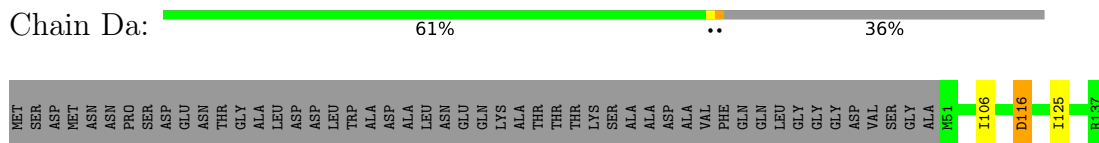

- Molecule 13: Flagellar motor switch protein FlIN

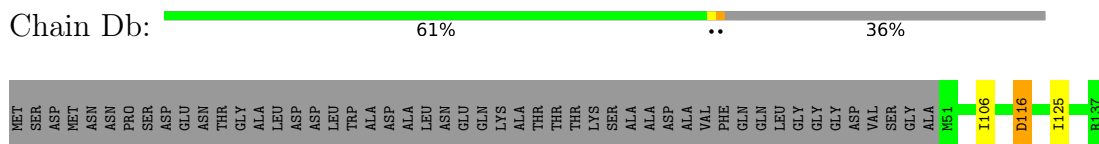

- Molecule 13: Flagellar motor switch protein FlIN

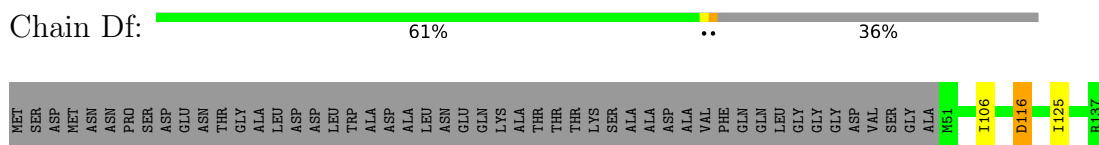

- Molecule 13: Flagellar motor switch protein FlIN

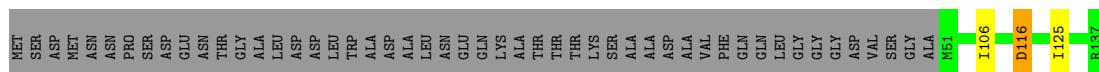

● Molecule 13: Flagellar motor switch protein FliN

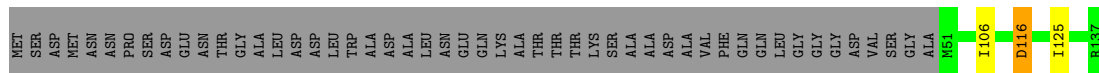

● Molecule 13: Flagellar motor switch protein FliN

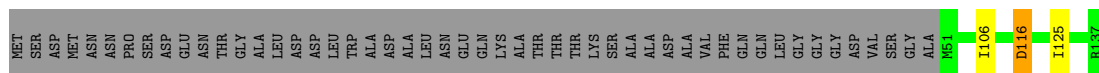

● Molecule 13: Flagellar motor switch protein FliN

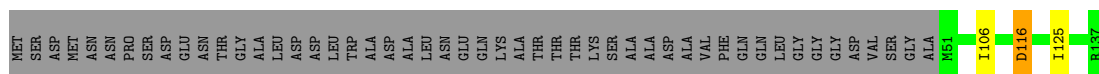

● Molecule 13: Flagellar motor switch protein FliN

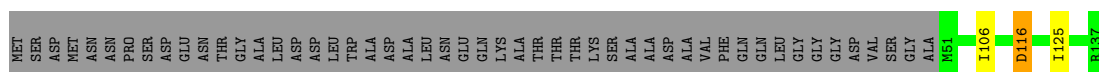

● Molecule 13: Flagellar motor switch protein FliN

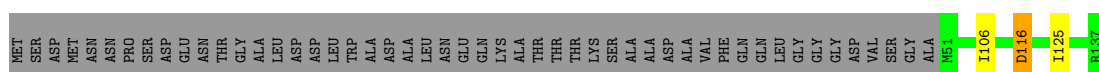

● Molecule 13: Flagellar motor switch protein FliN

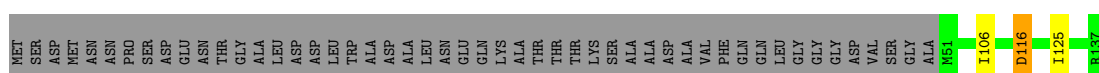

● Molecule 13: Flagellar motor switch protein FliN

Chain Dt:  61% .. 36%

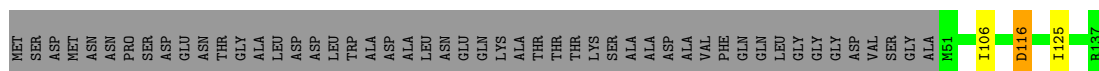

• Molecule 13: Flagellar motor switch protein FliN

Chain Dx:  61% .. 36%

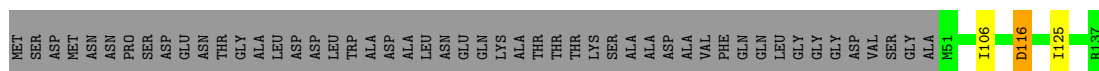

• Molecule 13: Flagellar motor switch protein FliN

Chain Dy:  61% .. 36%

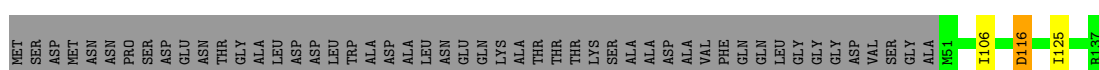

• Molecule 13: Flagellar motor switch protein FliN

Chain Dz:  61% .. 36%

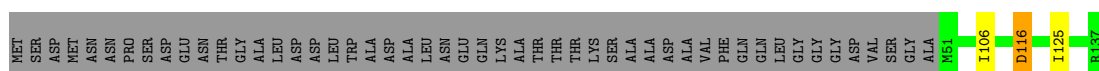

• Molecule 13: Flagellar motor switch protein FliN

Chain D4:  61% .. 36%

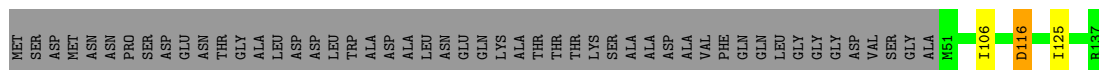

• Molecule 13: Flagellar motor switch protein FliN

Chain D5:  61% .. 36%

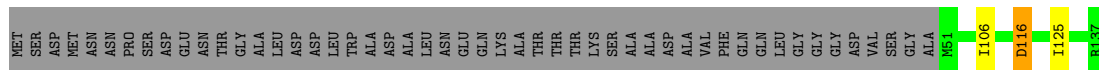

• Molecule 13: Flagellar motor switch protein FliN

Chain D6:  61% .. 36%

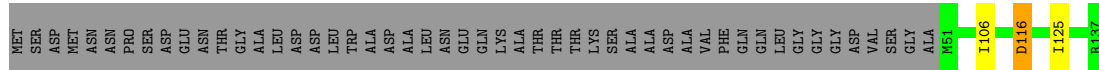

• Molecule 13: Flagellar motor switch protein FliN

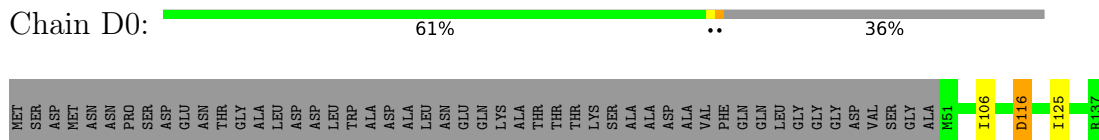

● Molecule 13: Flagellar motor switch protein FliN

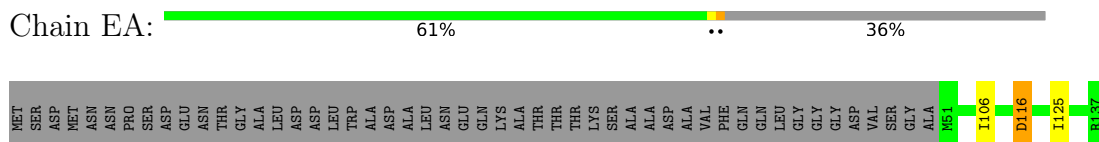

● Molecule 13: Flagellar motor switch protein FliN

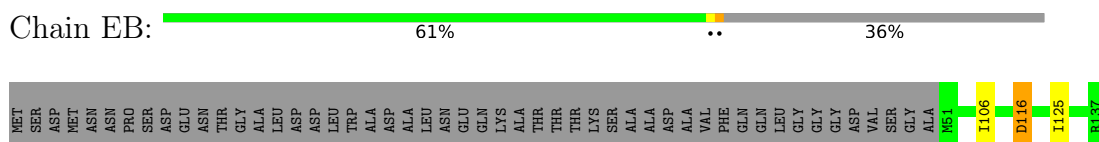

● Molecule 13: Flagellar motor switch protein FliN

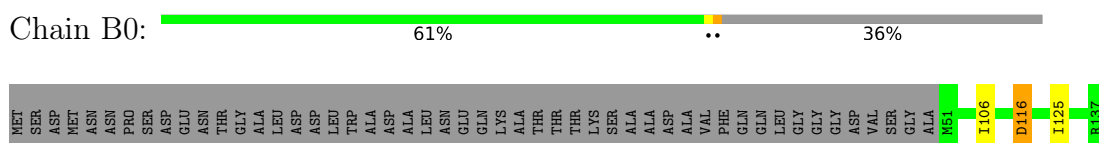

● Molecule 13: Flagellar motor switch protein FliN

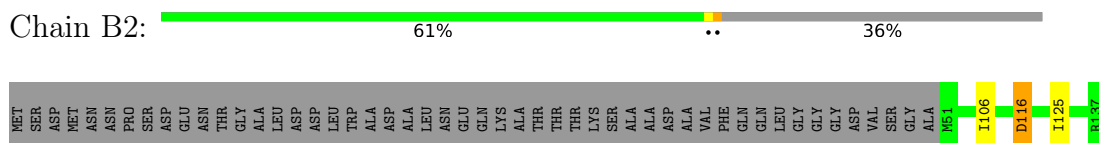

● Molecule 13: Flagellar motor switch protein FliN

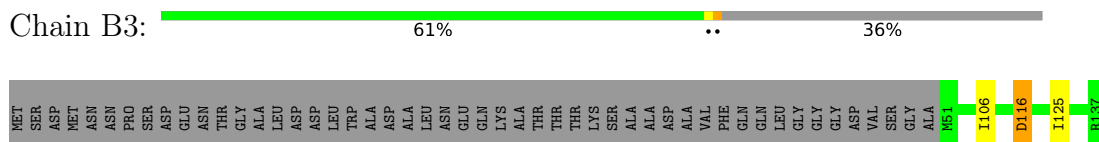

● Molecule 13: Flagellar motor switch protein FliN

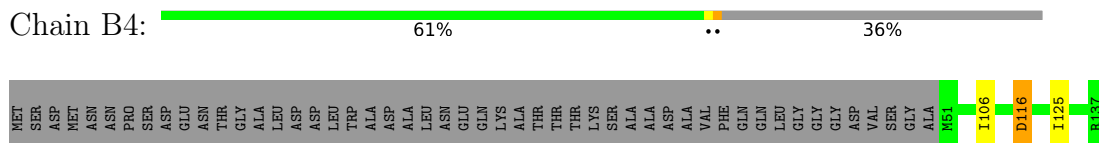

● Molecule 13: Flagellar motor switch protein FliN

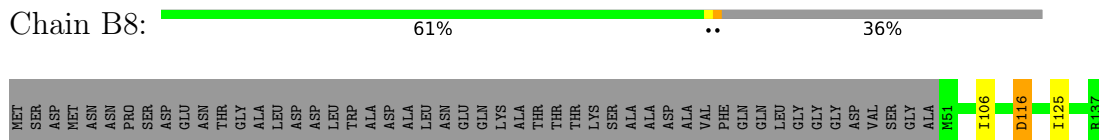

- Molecule 13: Flagellar motor switch protein FliN

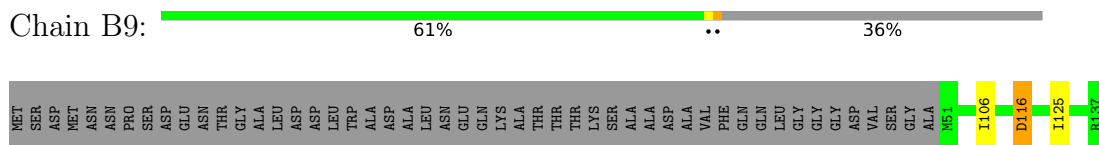

- Molecule 13: Flagellar motor switch protein FliN

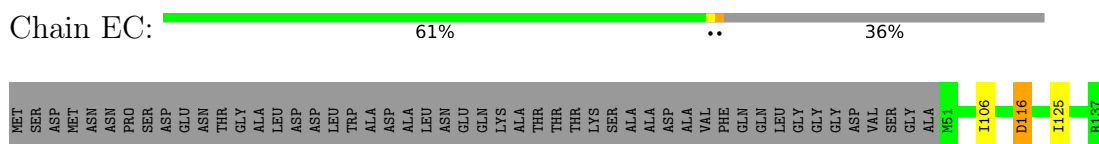

- Molecule 13: Flagellar motor switch protein FliN

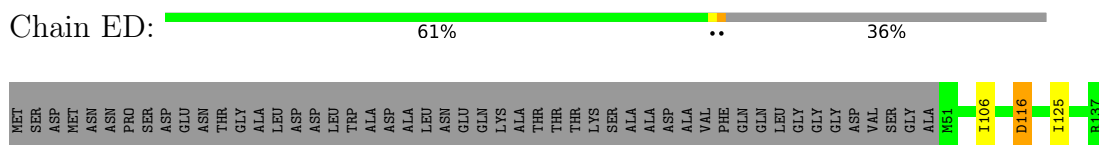

- Molecule 13: Flagellar motor switch protein FliN

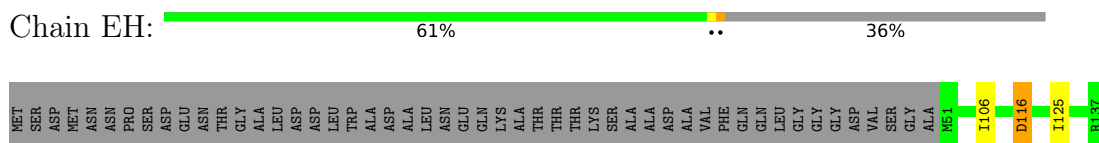

- Molecule 13: Flagellar motor switch protein FliN

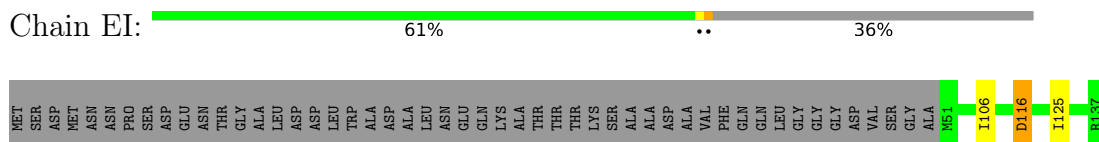

- Molecule 13: Flagellar motor switch protein FliN

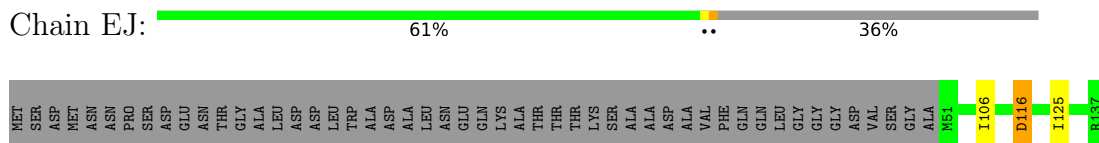

- Molecule 13: Flagellar motor switch protein FliN

Chain EN: 

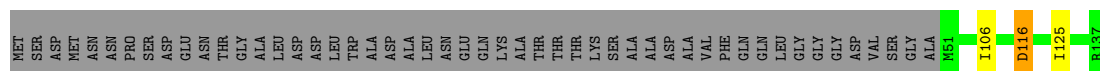

- Molecule 13: Flagellar motor switch protein FliN

Chain EO: 

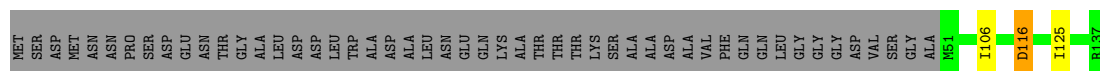

- Molecule 13: Flagellar motor switch protein FliN

Chain EP: 

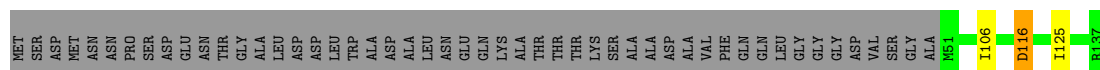

- Molecule 13: Flagellar motor switch protein FliN

Chain ET: 

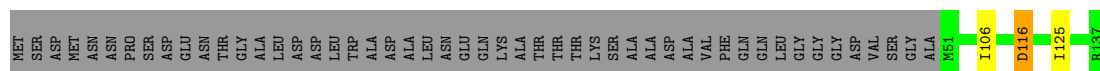

- Molecule 13: Flagellar motor switch protein FliN

Chain EU: 

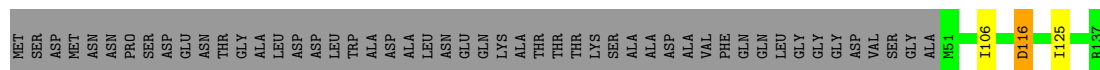

- Molecule 13: Flagellar motor switch protein FliN

Chain EV: 

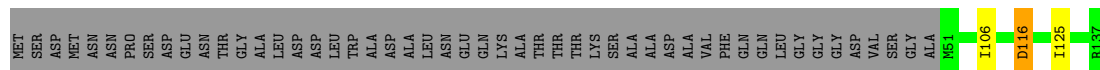

- Molecule 13: Flagellar motor switch protein FliN

Chain EZ: 

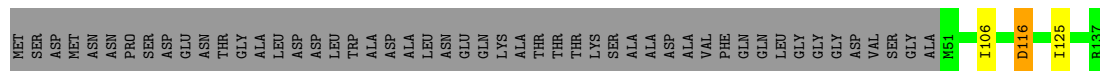

- Molecule 13: Flagellar motor switch protein FliN

Chain BY: 

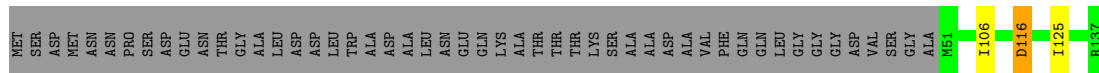

- Molecule 13: Flagellar motor switch protein FliN

Chain BZ: 



- Molecule 13: Flagellar motor switch protein FliN

Chain Bd: 

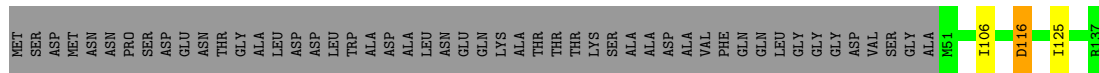

- Molecule 13: Flagellar motor switch protein FliN

Chain Be: 

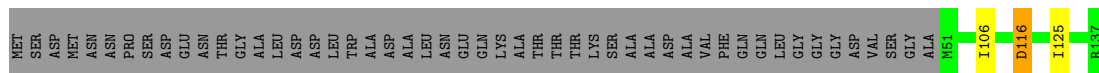

- Molecule 13: Flagellar motor switch protein FliN

Chain Bf: 

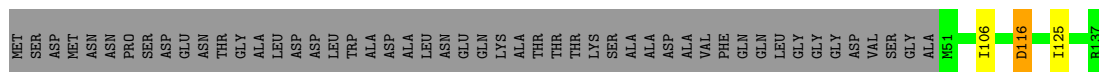

- Molecule 13: Flagellar motor switch protein FliN

Chain Bj: 

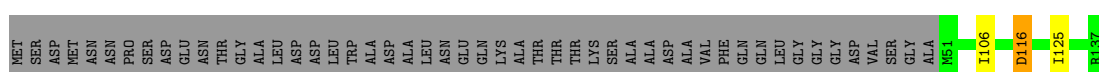

- Molecule 13: Flagellar motor switch protein FliN

Chain Bk: 

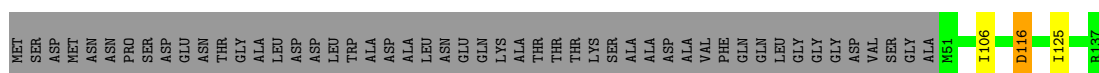

- Molecule 13: Flagellar motor switch protein FliN

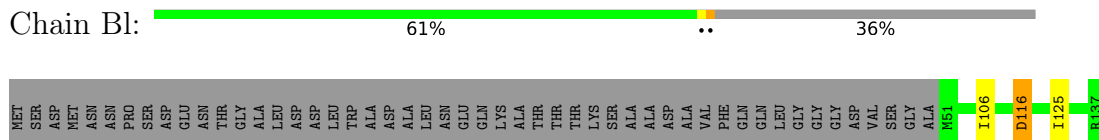

● Molecule 13: Flagellar motor switch protein FliN

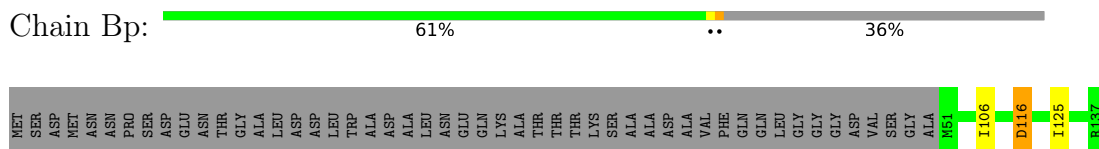

● Molecule 13: Flagellar motor switch protein FliN

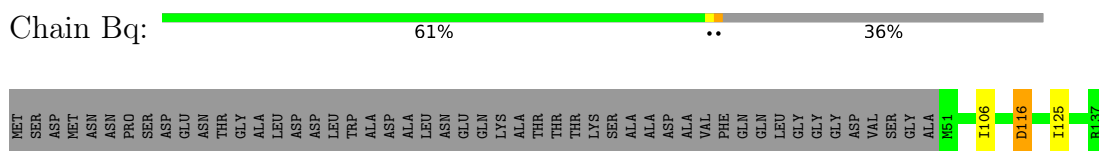

● Molecule 13: Flagellar motor switch protein FliN

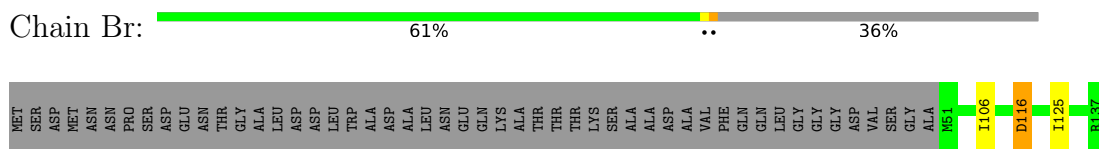

● Molecule 13: Flagellar motor switch protein FliN

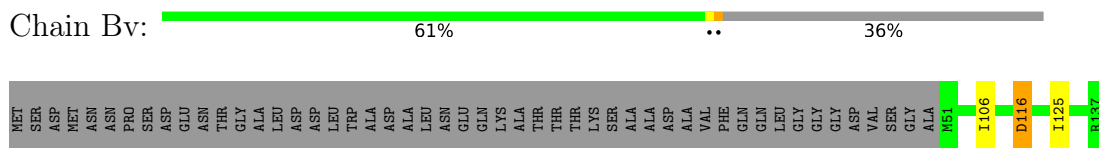

● Molecule 13: Flagellar motor switch protein FliN

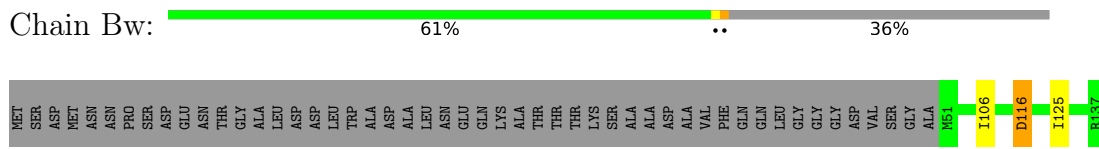

● Molecule 13: Flagellar motor switch protein FliN

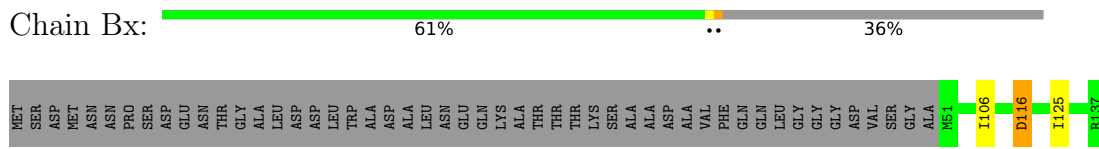

● Molecule 13: Flagellar motor switch protein FliN

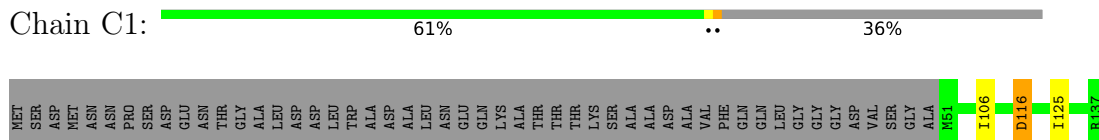

- Molecule 13: Flagellar motor switch protein FliN

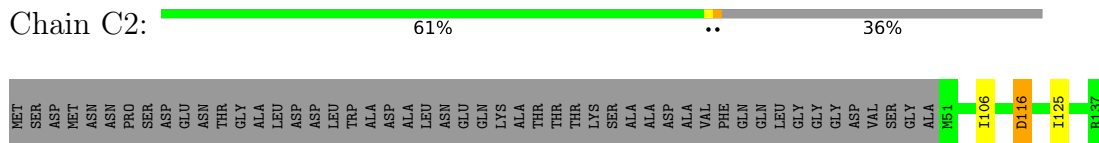

- Molecule 13: Flagellar motor switch protein FliN

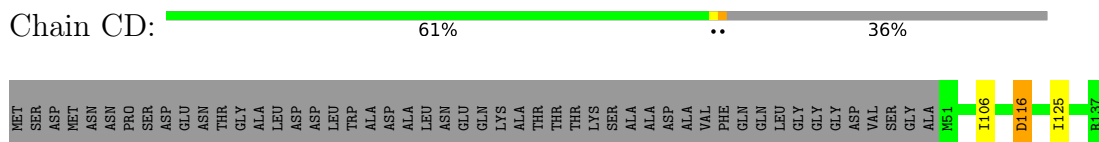

- Molecule 13: Flagellar motor switch protein FliN

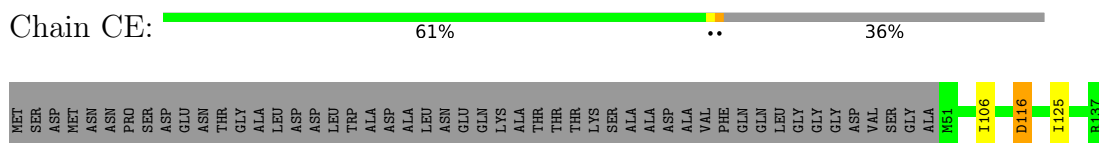

- Molecule 13: Flagellar motor switch protein FliN

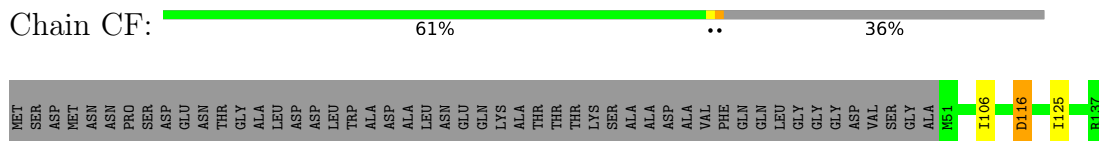

- Molecule 13: Flagellar motor switch protein FliN

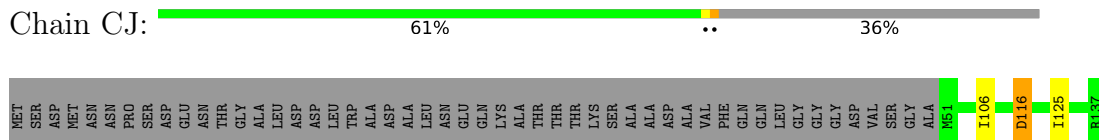

- Molecule 13: Flagellar motor switch protein FliN

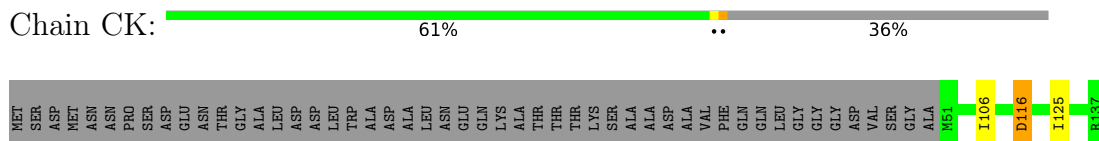

- Molecule 13: Flagellar motor switch protein FliN

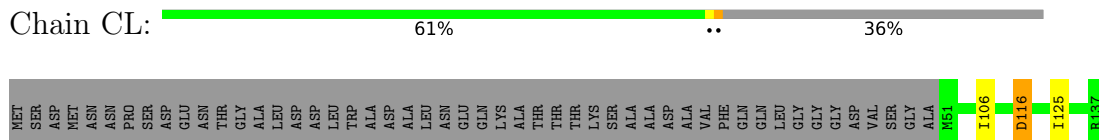

- Molecule 13: Flagellar motor switch protein FliN

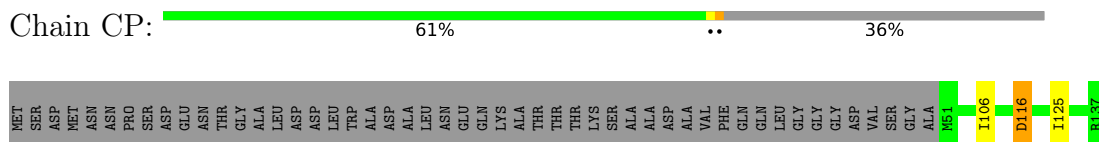

- Molecule 13: Flagellar motor switch protein FliN

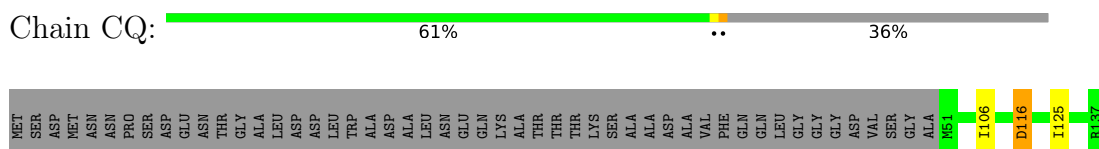

- Molecule 13: Flagellar motor switch protein FliN

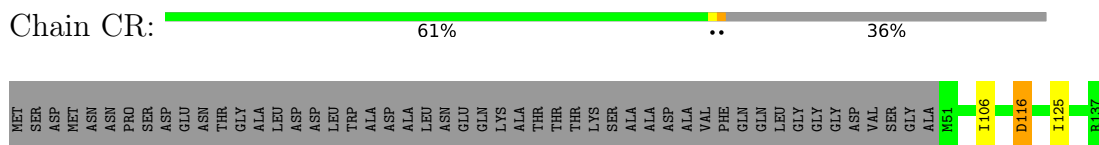

- Molecule 13: Flagellar motor switch protein FliN

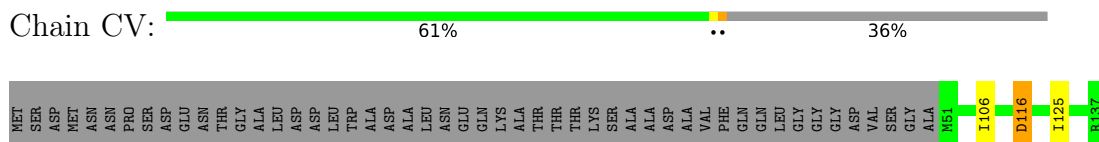

- Molecule 13: Flagellar motor switch protein FliN

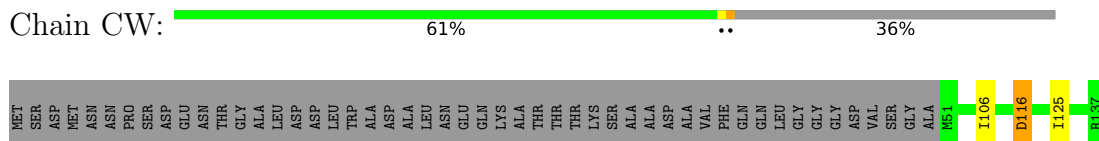

- Molecule 13: Flagellar motor switch protein FliN

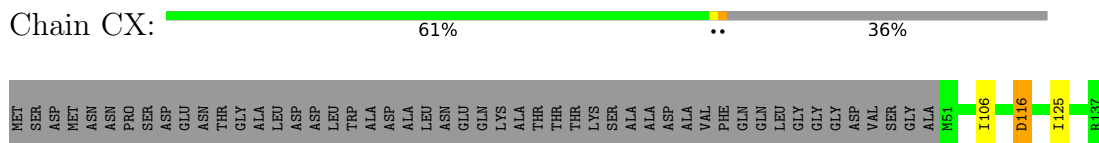

- Molecule 13: Flagellar motor switch protein FliN

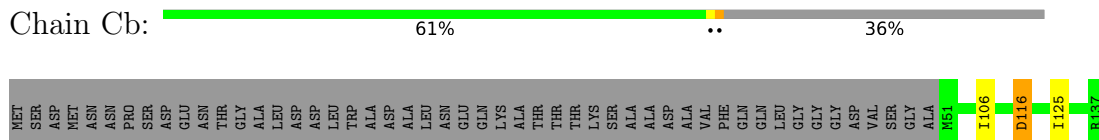

• Molecule 13: Flagellar motor switch protein FliN

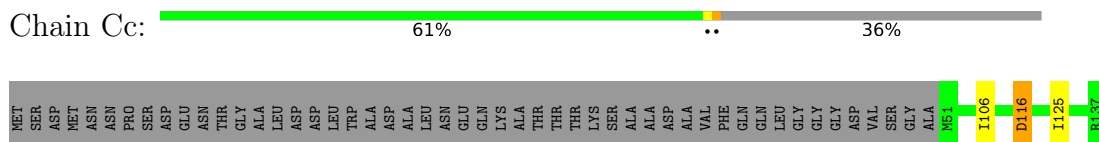

• Molecule 13: Flagellar motor switch protein FliN

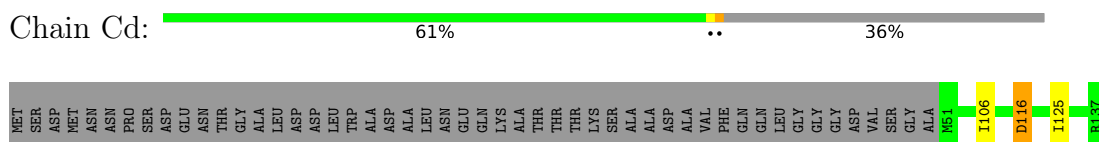

• Molecule 13: Flagellar motor switch protein FliN

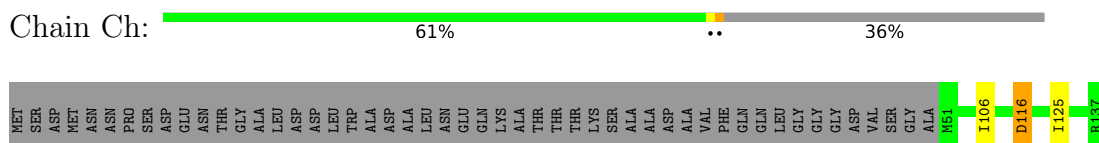

• Molecule 13: Flagellar motor switch protein FliN

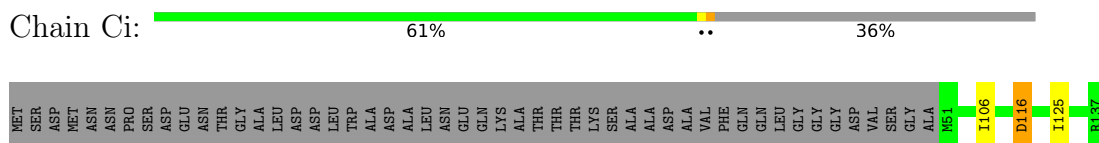

• Molecule 13: Flagellar motor switch protein FliN

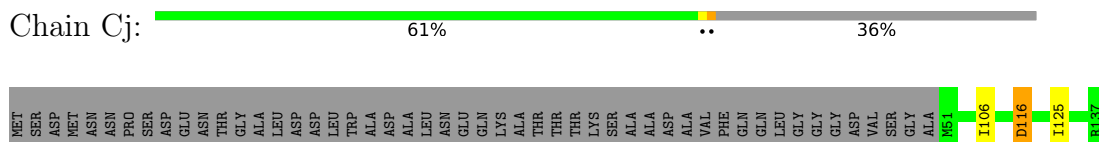

• Molecule 13: Flagellar motor switch protein FliN

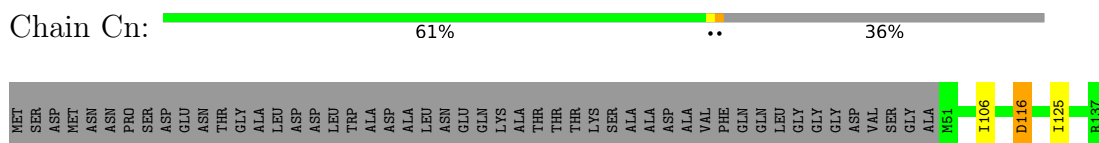

• Molecule 13: Flagellar motor switch protein FliN

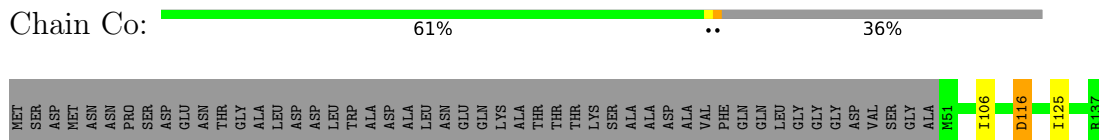

• Molecule 13: Flagellar motor switch protein FliN

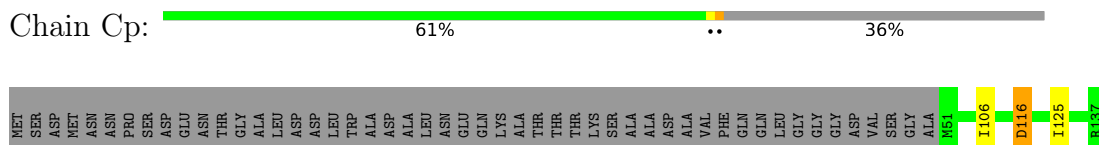

• Molecule 13: Flagellar motor switch protein FliN

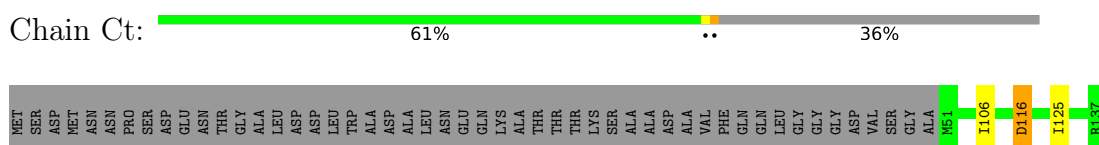

• Molecule 13: Flagellar motor switch protein FliN

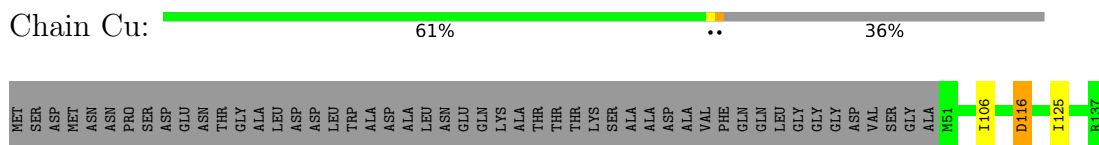

• Molecule 13: Flagellar motor switch protein FliN

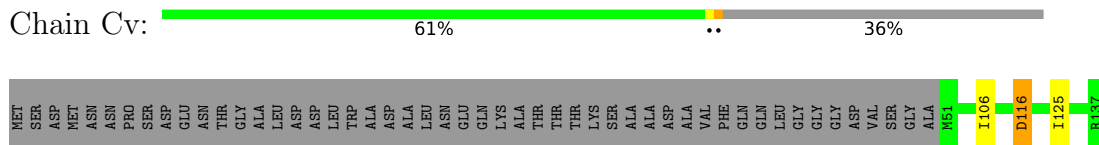

• Molecule 13: Flagellar motor switch protein FliN

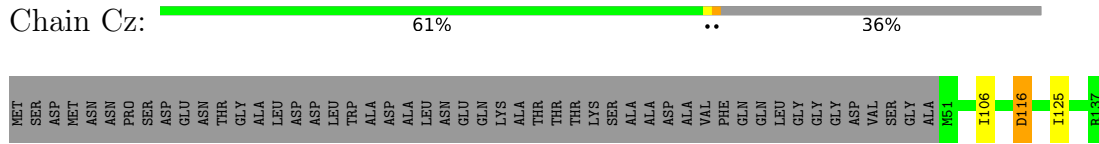

• Molecule 13: Flagellar motor switch protein FliN

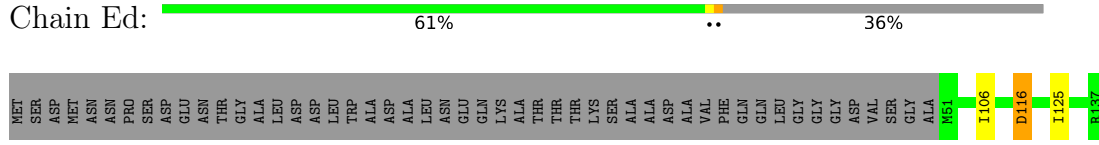

• Molecule 13: Flagellar motor switch protein FliN

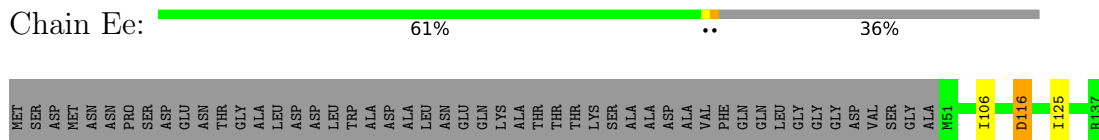

● Molecule 13: Flagellar motor switch protein FliN

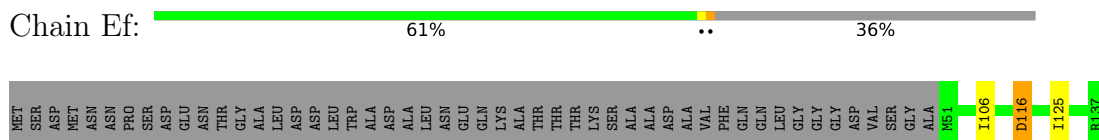

● Molecule 13: Flagellar motor switch protein FliN

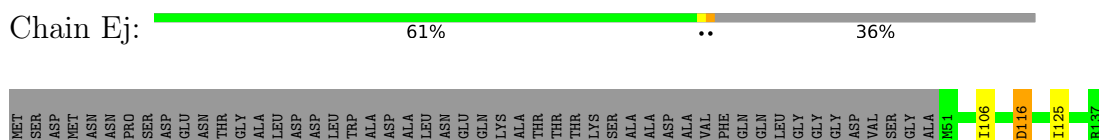

● Molecule 13: Flagellar motor switch protein FliN

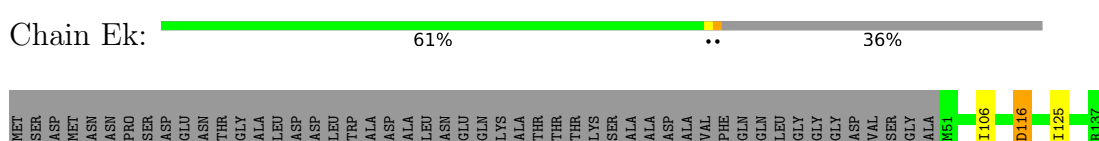

● Molecule 13: Flagellar motor switch protein FliN

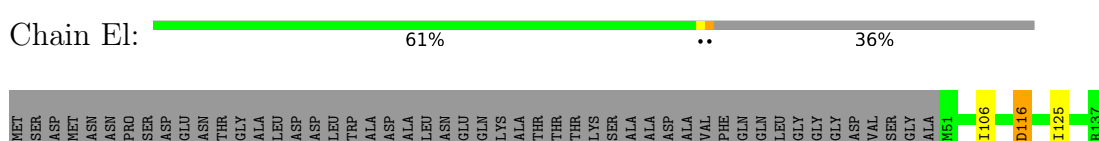

● Molecule 13: Flagellar motor switch protein FliN

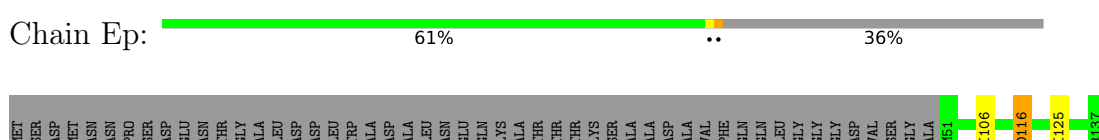

● Molecule 14: Flagellar motor switch protein FliG

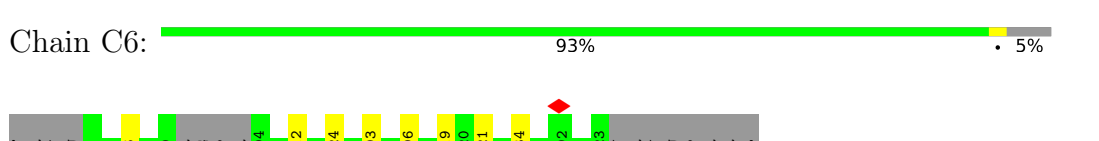

● Molecule 14: Flagellar motor switch protein FliG

Chain DB:  93% • 5%



• Molecule 14: Flagellar motor switch protein Flig

Chain DD:  93% • 5%



• Molecule 14: Flagellar motor switch protein Flig

Chain DJ:  93% • 5%



• Molecule 14: Flagellar motor switch protein Flig

Chain DQ:  93% • 5%



• Molecule 14: Flagellar motor switch protein Flig

Chain DW:  93% • 5%



• Molecule 14: Flagellar motor switch protein Flig

Chain Dc:  93% • 5%



• Molecule 14: Flagellar motor switch protein Flig

Chain Di:  93% • 5%



• Molecule 14: Flagellar motor switch protein Flig

Chain Do:  93% • 5%



• Molecule 14: Flagellar motor switch protein Flig

Chain Du:  93% • 5%



• Molecule 14: Flagellar motor switch protein Flig

Chain D1:  93% • 5%



• Molecule 14: Flagellar motor switch protein Flig

Chain D7:  93% • 5%



• Molecule 14: Flagellar motor switch protein Flig

Chain B5:  93% • 5%



• Molecule 14: Flagellar motor switch protein Flig

Chain EE:  93% • 5%



• Molecule 14: Flagellar motor switch protein Flig

Chain EK:  93% • 5%



• Molecule 14: Flagellar motor switch protein Flig



• Molecule 14: Flagellar motor switch protein Flig

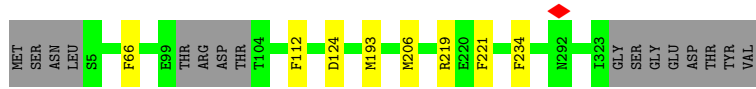

• Molecule 14: Flagellar motor switch protein Flig



• Molecule 14: Flagellar motor switch protein Flig

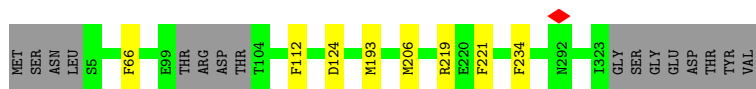

• Molecule 14: Flagellar motor switch protein Flig



• Molecule 14: Flagellar motor switch protein Flig



• Molecule 14: Flagellar motor switch protein Flig

Chain By:  93% • 5%



- Molecule 14: Flagellar motor switch protein Flig

Chain CA:  93% • 5%



- Molecule 14: Flagellar motor switch protein Flig

Chain CG:  93% • 5%



- Molecule 14: Flagellar motor switch protein Flig

Chain CM:  93% • 5%



- Molecule 14: Flagellar motor switch protein Flig

Chain CS:  93% • 5%



- Molecule 14: Flagellar motor switch protein Flig

Chain CY:  93% • 5%



- Molecule 14: Flagellar motor switch protein Flig

Chain Ce:  93% • 5%



- Molecule 14: Flagellar motor switch protein FliG

Chain Ck:  93% • 5%



- Molecule 14: Flagellar motor switch protein FliG

Chain Cq:  93% • 5%



- Molecule 14: Flagellar motor switch protein FliG

Chain Cw:  93% • 5%



- Molecule 14: Flagellar motor switch protein FliG

Chain Ea:  93% • 5%



- Molecule 14: Flagellar motor switch protein FliG

Chain Eg:  93% • 5%

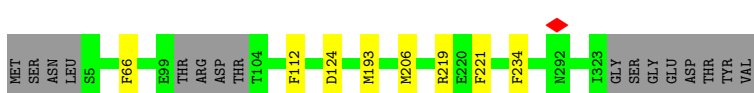

- Molecule 14: Flagellar motor switch protein FliG

Chain Em:  93% • 5%



- Molecule 15: Flagellar motor switch protein FliM

Chain C8:  82% • 13%

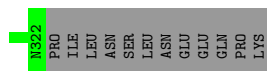
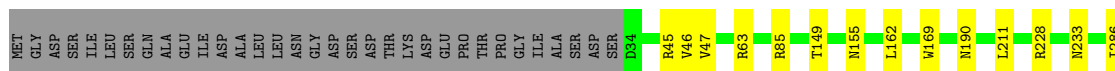

• Molecule 15: Flagellar motor switch protein FlIM

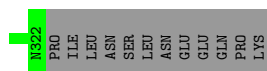
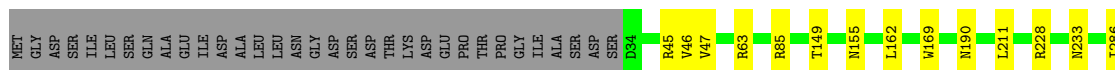
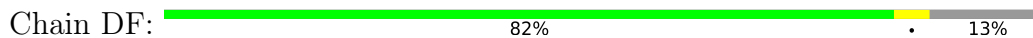

• Molecule 15: Flagellar motor switch protein FlIM

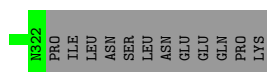
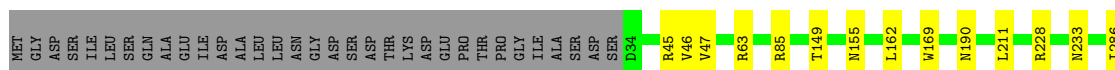
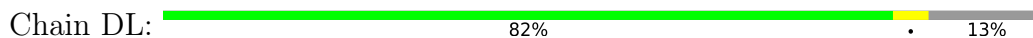

• Molecule 15: Flagellar motor switch protein FlIM

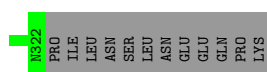
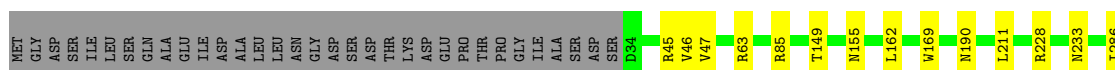
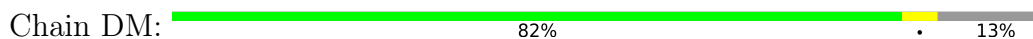

• Molecule 15: Flagellar motor switch protein FlIM

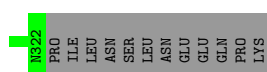
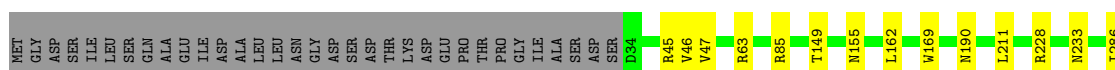
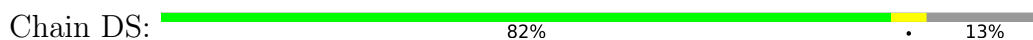

• Molecule 15: Flagellar motor switch protein FlIM

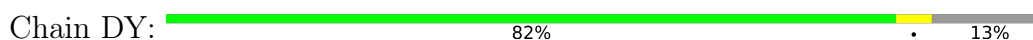

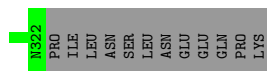
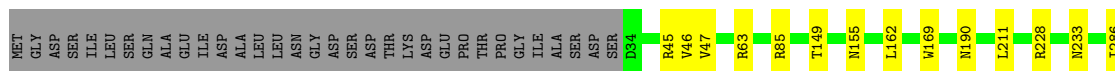

• Molecule 15: Flagellar motor switch protein FlIM

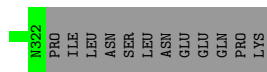
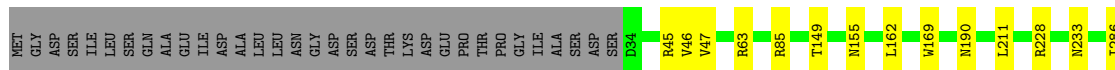
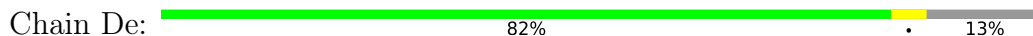

• Molecule 15: Flagellar motor switch protein FlIM

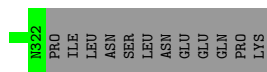
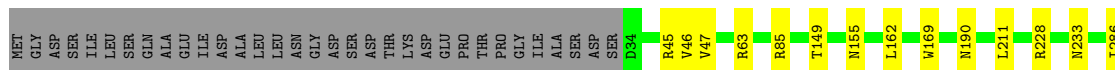
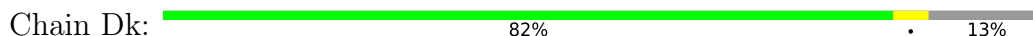

• Molecule 15: Flagellar motor switch protein FlIM

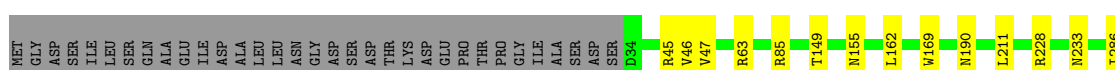
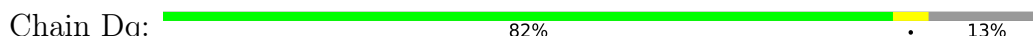

• Molecule 15: Flagellar motor switch protein FlIM

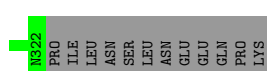
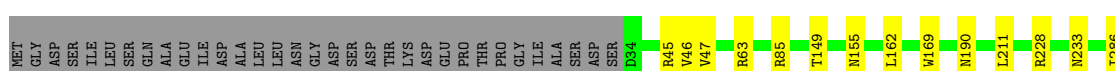
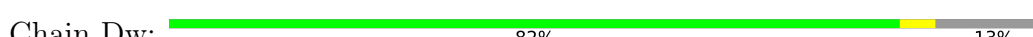

• Molecule 15: Flagellar motor switch protein FlIM

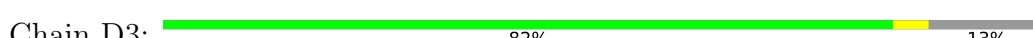

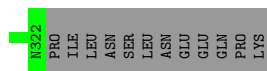
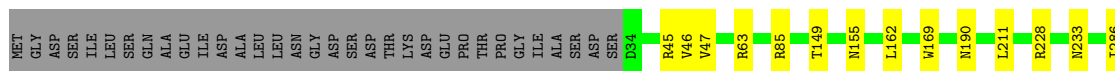

• Molecule 15: Flagellar motor switch protein FlIM

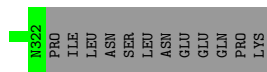
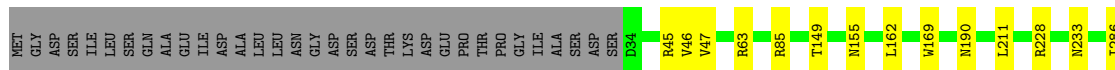
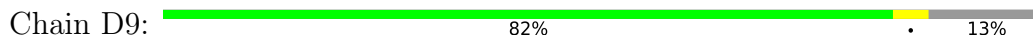

• Molecule 15: Flagellar motor switch protein FlIM

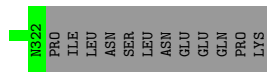
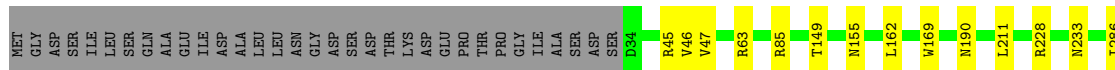

• Molecule 15: Flagellar motor switch protein FlIM

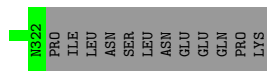
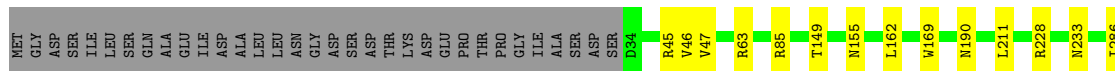
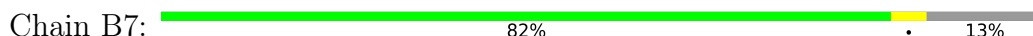

• Molecule 15: Flagellar motor switch protein FlIM

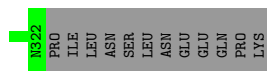
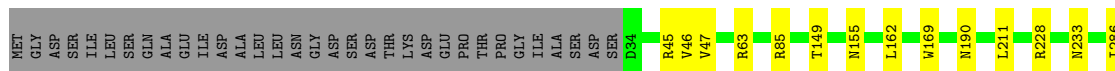
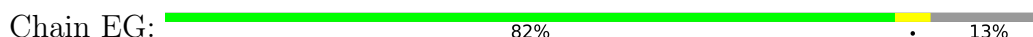

• Molecule 15: Flagellar motor switch protein FlIM



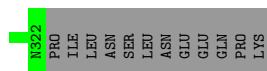
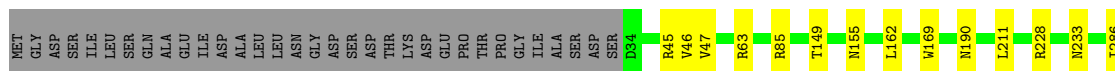

• Molecule 15: Flagellar motor switch protein FlIM

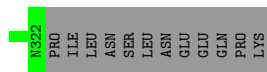
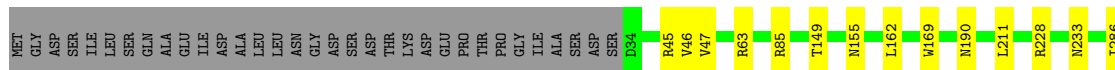
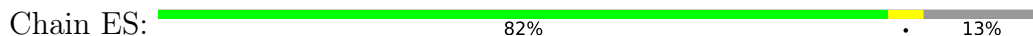

• Molecule 15: Flagellar motor switch protein FlIM

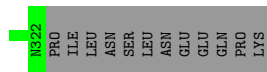
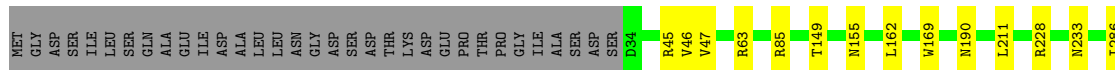
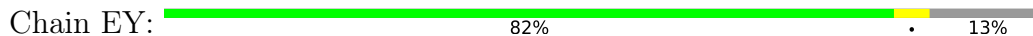

• Molecule 15: Flagellar motor switch protein FlIM

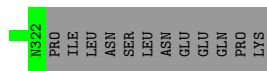
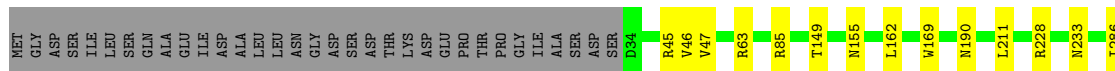
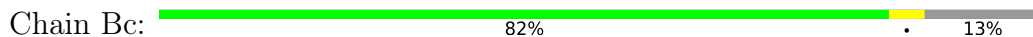

• Molecule 15: Flagellar motor switch protein FlIM

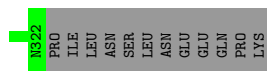
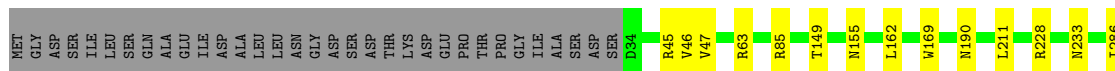
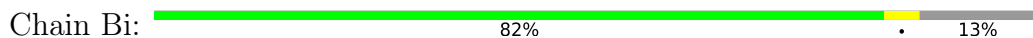

• Molecule 15: Flagellar motor switch protein FlIM

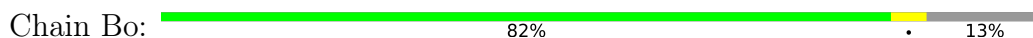

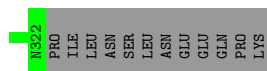
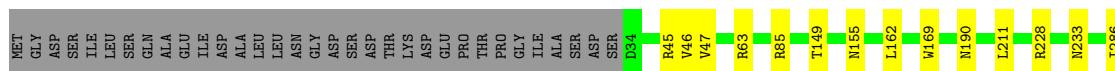

• Molecule 15: Flagellar motor switch protein FlIM

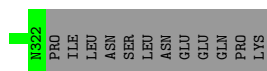
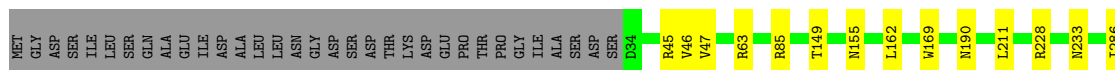
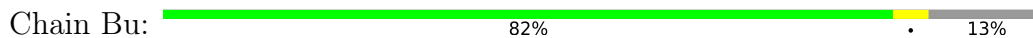

• Molecule 15: Flagellar motor switch protein FlIM

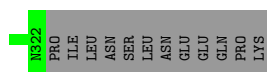
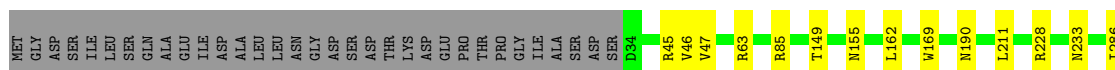
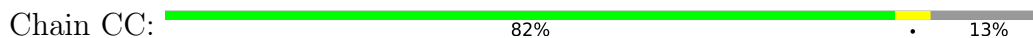

• Molecule 15: Flagellar motor switch protein FlIM

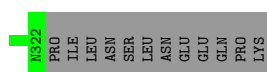
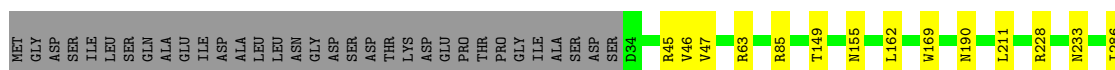
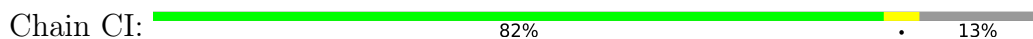

• Molecule 15: Flagellar motor switch protein FlIM

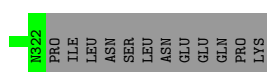
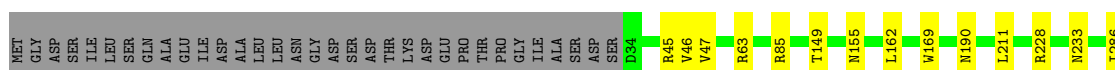
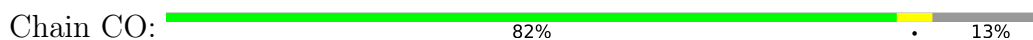

• Molecule 15: Flagellar motor switch protein FlIM

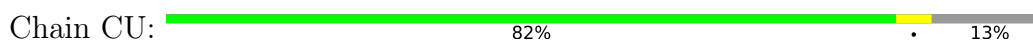

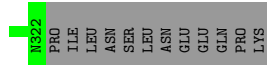
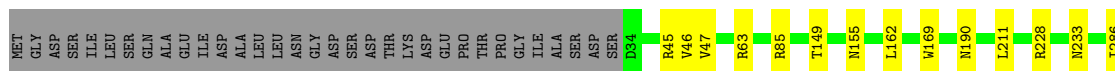

• Molecule 15: Flagellar motor switch protein FlIM

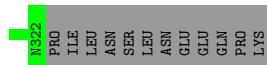
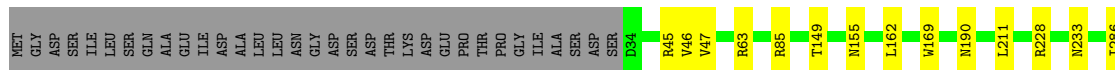
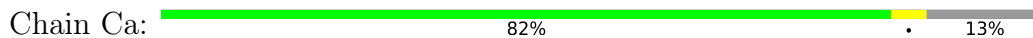

• Molecule 15: Flagellar motor switch protein FlIM

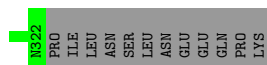
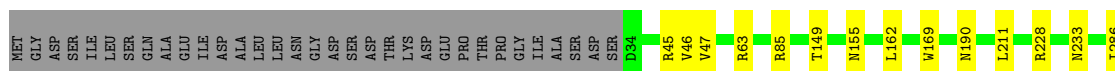
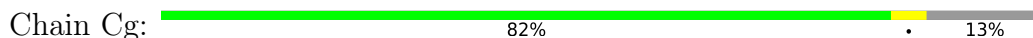

• Molecule 15: Flagellar motor switch protein FlIM

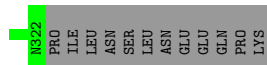
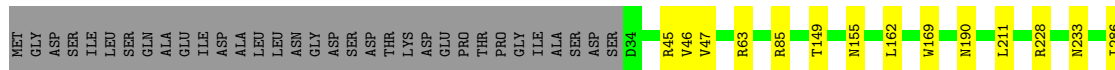

• Molecule 15: Flagellar motor switch protein FlIM

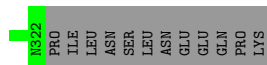
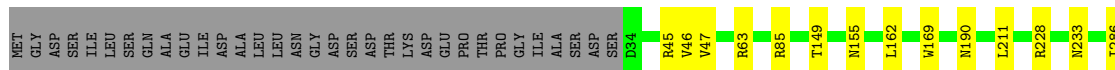
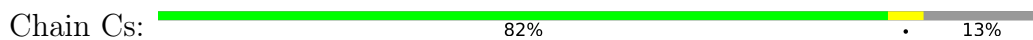

• Molecule 15: Flagellar motor switch protein FlIM

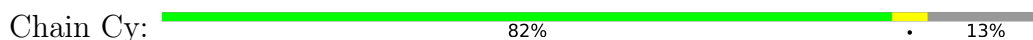

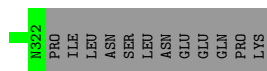
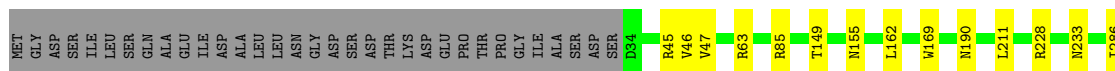

• Molecule 15: Flagellar motor switch protein FlIM

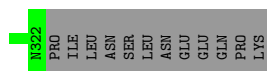
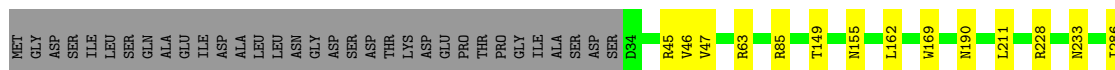
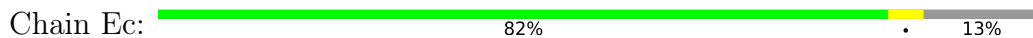

• Molecule 15: Flagellar motor switch protein FlIM

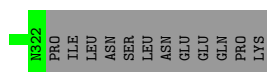
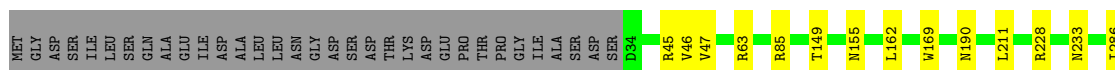
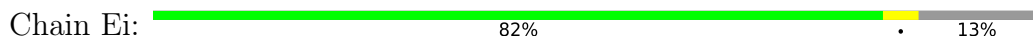

• Molecule 15: Flagellar motor switch protein FlIM

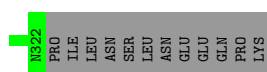
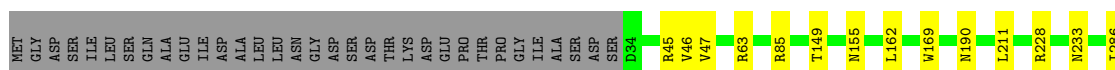
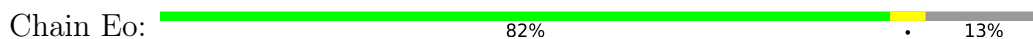

4 Experimental information

Property	Value	Source
EM reconstruction method	SINGLE PARTICLE	Depositor
Imposed symmetry	POINT, C34	Depositor
Number of particles used	10318	Depositor
Resolution determination method	FSC 0.143 CUT-OFF	Depositor
CTF correction method	PHASE FLIPPING AND AMPLITUDE CORRECTION	Depositor
Microscope	FEI TITAN KRIOS	Depositor
Voltage (kV)	300	Depositor
Electron dose ($e^-/\text{\AA}^2$)	41	Depositor
Minimum defocus (nm)	1500	Depositor
Maximum defocus (nm)	1800	Depositor
Magnification	81000	Depositor
Image detector	GATAN K3 (6k x 4k)	Depositor
Maximum map value	0.608	Depositor
Minimum map value	-0.537	Depositor
Average map value	0.000	Depositor
Map value standard deviation	0.031	Depositor
Recommended contour level	0.05	Depositor
Map size (Å)	880.0, 880.0, 880.0	wwPDB
Map dimensions	800, 800, 800	wwPDB
Map angles (°)	90.0, 90.0, 90.0	wwPDB
Pixel spacing (Å)	1.1, 1.1, 1.1	Depositor

5 Model quality i

5.1 Standard geometry i

The Z score for a bond length (or angle) is the number of standard deviations the observed value is removed from the expected value. A bond length (or angle) with $|Z| > 5$ is considered an outlier worth inspection. RMSZ is the root-mean-square of all Z scores of the bond lengths (or angles).

Mol	Chain	Bond lengths		Bond angles	
		RMSZ	# Z >5	RMSZ	# Z >5
1	0	0.33	0/1888	0.54	1/2564 (0.0%)
1	1	0.31	0/1917	0.51	0/2605
1	2	0.29	0/1973	0.50	0/2682
1	3	0.28	0/1973	0.52	0/2682
1	4	0.28	0/1973	0.51	0/2682
1	5	0.33	0/1973	0.52	0/2682
1	6	0.32	0/1973	0.54	0/2682
1	7	0.32	0/1973	0.53	0/2682
1	8	0.33	0/1973	0.56	0/2682
1	9	0.30	0/1973	0.53	1/2682 (0.0%)
1	AF	0.34	0/1926	0.53	0/2618
1	AG	0.38	0/1934	0.59	0/2629
1	AH	0.39	0/1942	0.56	0/2639
1	AI	0.35	0/1926	0.58	1/2618 (0.0%)
1	AJ	0.34	0/1934	0.54	0/2629
1	AK	0.34	0/1844	0.51	0/2505
1	AL	0.33	0/1888	0.52	0/2564
1	AM	0.33	0/1888	0.56	1/2564 (0.0%)
1	AN	0.31	0/1888	0.52	0/2564
1	ZA	0.31	0/1973	0.53	0/2682
1	ZB	0.29	0/1973	0.49	0/2682
1	ZC	0.34	0/1973	0.54	0/2682
1	ZD	0.31	0/1973	0.52	0/2682
1	ZE	0.30	0/1973	0.51	1/2682 (0.0%)
2	A	0.30	0/1613	0.51	0/2194
2	B	0.30	0/1613	0.51	0/2194
2	C	0.30	0/1613	0.51	0/2194
2	D	0.30	0/1613	0.51	0/2194
2	E	0.30	0/1613	0.51	0/2194
2	F	0.30	0/1613	0.51	0/2194
2	G	0.30	0/1613	0.51	0/2194
2	H	0.30	0/1613	0.51	0/2194
2	I	0.30	0/1613	0.51	0/2194
2	J	0.30	0/1613	0.51	0/2194

Mol	Chain	Bond lengths		Bond angles	
		RMSZ	# Z >5	RMSZ	# Z >5
2	K	0.30	0/1613	0.51	0/2194
2	L	0.30	0/1613	0.51	0/2194
2	M	0.30	0/1613	0.51	0/2194
2	N	0.30	0/1613	0.51	0/2194
2	O	0.30	0/1613	0.51	0/2194
2	P	0.30	0/1613	0.51	0/2194
2	Q	0.30	0/1613	0.51	0/2194
2	R	0.30	0/1613	0.51	0/2194
2	S	0.30	0/1613	0.51	0/2194
2	T	0.29	0/1613	0.51	0/2194
2	U	0.30	0/1613	0.51	0/2194
2	V	0.30	0/1613	0.51	0/2194
2	W	0.29	0/1613	0.51	0/2194
2	X	0.30	0/1613	0.51	0/2194
2	Y	0.30	0/1613	0.51	0/2194
2	Z	0.30	0/1613	0.51	0/2194
3	A0	0.34	0/959	0.50	0/1293
3	A6	0.37	0/1042	0.56	0/1408
3	A7	0.33	0/951	0.50	0/1282
3	A8	0.35	0/976	0.56	0/1316
3	A9	0.35	0/991	0.54	0/1335
4	A1	0.36	0/675	0.49	0/905
4	A2	0.37	0/689	0.52	0/925
4	A3	0.36	0/689	0.50	0/925
4	A4	0.37	0/689	0.53	0/925
4	A5	0.40	0/682	0.52	0/915
4	Az	0.43	0/428	0.57	0/572
5	AA	0.33	0/1828	0.56	0/2492
5	AB	0.33	0/1836	0.56	2/2502 (0.1%)
5	AC	0.37	0/1844	0.57	0/2512
5	AD	0.33	0/1844	0.57	0/2512
5	AE	0.33	0/1836	0.58	0/2502
6	AO	0.27	0/1289	0.53	0/1741
6	AP	0.27	0/1289	0.53	0/1741
6	AQ	0.27	0/1289	0.53	0/1741
6	AR	0.27	0/1289	0.53	0/1741
6	AS	0.27	0/1289	0.53	0/1741
6	AT	0.27	0/1289	0.53	0/1741
6	AU	0.27	0/1289	0.53	0/1741
6	AV	0.27	0/1289	0.53	0/1741
6	AW	0.27	0/1289	0.53	0/1741
6	AX	0.27	0/1289	0.53	0/1741
6	AY	0.27	0/1289	0.53	0/1741

Mol	Chain	Bond lengths		Bond angles	
		RMSZ	# Z >5	RMSZ	# Z >5
6	AZ	0.27	0/1289	0.53	0/1741
6	Aa	0.27	0/1289	0.53	0/1741
6	Ac	0.27	0/1289	0.53	0/1741
6	Ad	0.27	0/1289	0.53	0/1741
6	Ae	0.27	0/1289	0.53	0/1741
6	Af	0.27	0/1289	0.53	0/1741
6	Ag	0.27	0/1289	0.53	0/1741
6	Ah	0.27	0/1289	0.53	0/1741
6	Ai	0.27	0/1289	0.53	0/1741
6	Aj	0.27	0/1289	0.53	0/1741
6	Ak	0.27	0/1289	0.53	0/1741
6	Al	0.27	0/1289	0.53	0/1741
6	Am	0.27	0/1289	0.53	0/1741
6	An	0.27	0/1289	0.53	0/1741
6	Ao	0.27	0/1289	0.53	0/1741
6	Ap	0.27	0/1289	0.53	0/1741
6	B6	0.22	0/226	0.48	0/303
6	BG	0.46	0/83	0.87	1/114 (0.9%)
6	BH	0.26	0/107	0.38	0/148
6	BI	0.31	0/137	0.49	0/191
6	BJ	0.28	0/107	0.57	0/148
6	BK	0.40	0/145	0.55	0/203
6	BL	0.33	0/107	0.51	0/148
6	BM	0.26	0/145	0.43	0/203
6	BN	0.30	0/107	0.38	0/148
6	BO	0.33	0/137	0.70	0/191
6	BP	0.30	0/107	0.37	0/148
6	BQ	0.29	0/145	0.45	0/203
6	BR	0.27	0/1289	0.53	0/1741
6	BS	0.27	0/1289	0.53	0/1741
6	BT	0.27	0/1289	0.53	0/1741
6	BU	0.27	0/1289	0.53	0/1741
6	BV	0.27	0/1289	0.53	0/1741
6	BW	0.27	0/1289	0.52	0/1741
6	BX	0.27	0/1289	0.53	0/1741
6	Bb	0.22	0/226	0.48	0/303
6	Bh	0.22	0/226	0.48	0/303
6	Bn	0.22	0/226	0.49	0/303
6	Bt	0.22	0/226	0.50	0/303
6	Bz	0.22	0/226	0.48	0/303
6	C3	0.22	0/226	0.49	0/303
6	C7	0.22	0/226	0.49	0/303
6	CB	0.22	0/226	0.49	0/303

Mol	Chain	Bond lengths		Bond angles	
		RMSZ	# Z >5	RMSZ	# Z >5
6	CH	0.22	0/226	0.48	0/303
6	CN	0.22	0/226	0.49	0/303
6	CT	0.21	0/226	0.48	0/303
6	CZ	0.22	0/226	0.49	0/303
6	Cf	0.22	0/226	0.49	0/303
6	Cl	0.22	0/226	0.49	0/303
6	Cr	0.22	0/226	0.49	0/303
6	Cx	0.22	0/226	0.49	0/303
6	D2	0.22	0/226	0.49	0/303
6	D8	0.22	0/226	0.48	0/303
6	DE	0.22	0/226	0.49	0/303
6	DK	0.22	0/226	0.48	0/303
6	DR	0.22	0/226	0.49	0/303
6	DX	0.22	0/226	0.49	0/303
6	Dd	0.22	0/226	0.48	0/303
6	Dj	0.22	0/226	0.48	0/303
6	Dp	0.22	0/226	0.48	0/303
6	Dv	0.22	0/226	0.49	0/303
6	EF	0.21	0/226	0.49	0/303
6	EL	0.22	0/226	0.49	0/303
6	ER	0.22	0/226	0.49	0/303
6	EX	0.22	0/226	0.49	0/303
6	Eb	0.22	0/226	0.49	0/303
6	Eh	0.22	0/226	0.48	0/303
6	En	0.22	0/226	0.48	0/303
6	UI	0.83	2/1191 (0.2%)	0.82	4/1618 (0.2%)
6	UJ	0.84	3/1191 (0.3%)	0.82	4/1618 (0.2%)
6	UK	0.83	2/1191 (0.2%)	0.83	4/1618 (0.2%)
6	UL	0.82	2/1191 (0.2%)	0.82	4/1618 (0.2%)
6	UM	0.84	2/1191 (0.2%)	0.82	4/1618 (0.2%)
6	UN	0.84	2/1191 (0.2%)	0.82	4/1618 (0.2%)
6	UO	0.83	2/1191 (0.2%)	0.82	4/1618 (0.2%)
6	UP	0.84	2/1191 (0.2%)	0.82	4/1618 (0.2%)
6	WA	0.60	0/863	0.72	1/1172 (0.1%)
6	WB	0.59	0/850	0.69	0/1154
6	WC	0.59	0/825	0.68	0/1121
6	WD	0.61	0/841	0.68	0/1142
6	WE	0.60	0/857	0.71	0/1164
6	WF	0.60	0/848	0.69	0/1152
6	WG	0.60	0/857	0.68	0/1164
6	WH	0.60	0/714	0.69	0/973
6	WI	0.60	0/714	0.74	0/973
6	WJ	0.61	0/749	0.72	1/1020 (0.1%)

Mol	Chain	Bond lengths		Bond angles	
		RMSZ	# Z >5	RMSZ	# Z >5
6	WK	0.60	0/741	0.69	0/1009
6	WL	0.59	0/631	0.70	0/860
6	WM	0.59	0/604	0.70	0/824
6	WN	0.60	0/619	0.70	0/844
6	WO	0.60	0/726	0.72	1/989 (0.1%)
6	WP	0.60	0/753	0.69	0/1025
6	WQ	0.60	0/848	0.69	0/1152
6	WR	0.60	0/848	0.69	0/1152
6	WS	0.61	0/848	0.69	0/1152
6	WT	0.60	0/848	0.71	0/1152
6	WU	0.60	0/857	0.67	0/1164
6	WV	0.62	0/841	0.69	0/1142
6	WW	0.60	0/848	0.70	0/1152
7	Ab	0.45	0/681	0.67	1/930 (0.1%)
7	Aq	0.33	0/681	0.53	0/930
7	Ar	0.28	0/681	0.50	0/930
7	As	0.27	0/681	0.48	0/930
8	At	0.31	0/1994	0.52	0/2724
9	Au	0.36	0/1643	0.62	2/2237 (0.1%)
9	Av	0.30	0/1665	0.49	1/2267 (0.0%)
9	Aw	0.29	0/1652	0.50	0/2249
9	Ax	0.29	0/1652	0.47	0/2249
9	Ay	0.33	0/1662	0.52	0/2263
10	BA	0.30	0/981	0.47	0/1334
10	BB	0.29	0/976	0.50	0/1327
10	BC	0.34	0/981	0.50	0/1334
10	BD	0.33	0/981	0.62	0/1334
10	BE	0.29	0/968	0.48	0/1316
10	BF	0.36	0/981	0.52	0/1334
11	ZF	0.28	0/2991	0.49	0/4076
11	ZG	0.34	0/2991	0.52	1/4076 (0.0%)
11	ZH	0.29	0/2991	0.50	0/4076
11	ZI	0.30	0/2991	0.51	0/4076
11	ZJ	0.31	0/2991	0.49	0/4076
11	ZK	0.30	0/2991	0.50	0/4076
11	ZL	0.29	0/2991	0.49	0/4076
11	ZM	0.29	0/2991	0.53	1/4076 (0.0%)
11	ZN	0.28	0/2991	0.51	0/4076
11	ZO	0.30	0/2991	0.50	0/4076
11	ZP	0.28	0/2991	0.50	1/4076 (0.0%)
11	ZQ	0.29	0/2991	0.51	0/4076
11	ZR	0.30	1/2991 (0.0%)	0.55	3/4076 (0.1%)
11	ZS	0.29	0/2991	0.52	1/4076 (0.0%)

Mol	Chain	Bond lengths		Bond angles	
		RMSZ	# Z >5	RMSZ	# Z >5
11	ZT	0.29	0/2991	0.48	0/4076
11	ZU	0.29	0/2991	0.50	0/4076
11	ZV	0.50	4/2991 (0.1%)	0.67	6/4076 (0.1%)
11	ZW	0.27	0/2991	0.49	0/4076
11	ZX	0.28	0/2991	0.48	0/4076
11	ZY	0.30	1/2991 (0.0%)	0.54	2/4076 (0.0%)
11	ZZ	0.26	0/2991	0.46	0/4076
11	Za	0.28	0/2991	0.49	0/4076
11	Zb	0.30	0/2991	0.49	0/4076
11	Zc	0.29	0/2991	0.52	2/4076 (0.0%)
11	Zd	0.30	0/2991	0.51	0/4076
11	Ze	0.28	0/2991	0.48	0/4076
11	Zf	0.27	0/2991	0.48	0/4076
11	Zg	0.28	0/2991	0.50	0/4076
11	Zh	0.28	0/2991	0.48	0/4076
12	a	0.31	0/2243	0.55	0/3041
12	b	0.31	0/2243	0.55	0/3041
12	c	0.31	0/2243	0.55	0/3041
12	d	0.31	0/2243	0.55	0/3041
12	e	0.31	0/2243	0.55	0/3041
12	f	0.31	0/2243	0.55	0/3041
12	g	0.30	0/2243	0.55	0/3041
12	h	0.31	0/2243	0.55	0/3041
12	i	0.31	0/2243	0.55	0/3041
12	j	0.31	0/2243	0.55	0/3041
12	k	0.31	0/2243	0.55	0/3041
12	l	0.30	0/2243	0.55	0/3041
12	m	0.30	0/2243	0.55	0/3041
12	n	0.31	0/2243	0.55	0/3041
12	o	0.30	0/2243	0.55	0/3041
12	p	0.31	0/2243	0.55	0/3041
12	q	0.31	0/2243	0.54	0/3041
12	r	0.31	0/2243	0.55	0/3041
12	s	0.30	0/2243	0.55	0/3041
12	t	0.31	0/2243	0.55	0/3041
12	u	0.31	0/2243	0.55	0/3041
12	v	0.31	0/2243	0.55	0/3041
12	w	0.31	0/2243	0.55	0/3041
12	x	0.31	0/2243	0.55	0/3041
12	y	0.31	0/2243	0.55	0/3041
12	z	0.31	0/2243	0.55	0/3041
13	B0	0.23	0/679	0.53	0/917
13	B2	0.23	0/679	0.52	0/917

Mol	Chain	Bond lengths		Bond angles	
		RMSZ	# Z >5	RMSZ	# Z >5
13	B3	0.23	0/679	0.52	0/917
13	B4	0.23	0/679	0.53	0/917
13	B8	0.23	0/679	0.53	0/917
13	B9	0.23	0/679	0.53	0/917
13	BY	0.23	0/679	0.53	0/917
13	BZ	0.23	0/679	0.53	0/917
13	Bd	0.23	0/679	0.53	0/917
13	Be	0.23	0/679	0.52	0/917
13	Bf	0.23	0/679	0.53	0/917
13	Bj	0.23	0/679	0.53	0/917
13	Bk	0.23	0/679	0.53	0/917
13	Bl	0.23	0/679	0.53	0/917
13	Bp	0.23	0/679	0.53	0/917
13	Bq	0.23	0/679	0.52	0/917
13	Br	0.23	0/679	0.53	0/917
13	Bv	0.23	0/679	0.53	0/917
13	Bw	0.23	0/679	0.52	0/917
13	Bx	0.23	0/679	0.53	0/917
13	C0	0.23	0/679	0.52	0/917
13	C1	0.23	0/679	0.52	0/917
13	C2	0.23	0/679	0.53	0/917
13	C4	0.23	0/679	0.52	0/917
13	C5	0.23	0/679	0.53	0/917
13	C9	0.23	0/679	0.53	0/917
13	CD	0.23	0/679	0.53	0/917
13	CE	0.23	0/679	0.52	0/917
13	CF	0.23	0/679	0.53	0/917
13	CJ	0.23	0/679	0.52	0/917
13	CK	0.23	0/679	0.52	0/917
13	CL	0.23	0/679	0.53	0/917
13	CP	0.23	0/679	0.53	0/917
13	CQ	0.23	0/679	0.53	0/917
13	CR	0.23	0/679	0.53	0/917
13	CV	0.23	0/679	0.53	0/917
13	CW	0.23	0/679	0.52	0/917
13	CX	0.23	0/679	0.53	0/917
13	Cb	0.23	0/679	0.53	0/917
13	Cc	0.23	0/679	0.52	0/917
13	Cd	0.23	0/679	0.53	0/917
13	Ch	0.23	0/679	0.53	0/917
13	Ci	0.23	0/679	0.53	0/917
13	Cj	0.23	0/679	0.53	0/917
13	Cn	0.23	0/679	0.53	0/917

Mol	Chain	Bond lengths		Bond angles	
		RMSZ	# Z >5	RMSZ	# Z >5
13	Co	0.23	0/679	0.52	0/917
13	Cp	0.23	0/679	0.53	0/917
13	Ct	0.23	0/679	0.53	0/917
13	Cu	0.23	0/679	0.53	0/917
13	Cv	0.23	0/679	0.53	0/917
13	Cz	0.23	0/679	0.52	0/917
13	D0	0.23	0/679	0.53	0/917
13	D4	0.23	0/679	0.53	0/917
13	D5	0.23	0/679	0.52	0/917
13	D6	0.23	0/679	0.53	0/917
13	DA	0.23	0/679	0.53	0/917
13	DC	0.23	0/679	0.53	0/917
13	DG	0.23	0/679	0.53	0/917
13	DH	0.23	0/679	0.53	0/917
13	DI	0.23	0/679	0.53	0/917
13	DN	0.23	0/679	0.53	0/917
13	DO	0.23	0/679	0.52	0/917
13	DP	0.23	0/679	0.53	0/917
13	DT	0.23	0/679	0.53	0/917
13	DU	0.23	0/679	0.52	0/917
13	DV	0.23	0/679	0.53	0/917
13	DZ	0.23	0/679	0.52	0/917
13	Da	0.23	0/679	0.52	0/917
13	Db	0.23	0/679	0.53	0/917
13	Df	0.23	0/679	0.53	0/917
13	Dg	0.23	0/679	0.53	0/917
13	Dh	0.23	0/679	0.53	0/917
13	Di	0.23	0/679	0.53	0/917
13	Dm	0.23	0/679	0.53	0/917
13	Dn	0.23	0/679	0.53	0/917
13	Dr	0.23	0/679	0.52	0/917
13	Ds	0.23	0/679	0.52	0/917
13	Dt	0.23	0/679	0.53	0/917
13	Dx	0.23	0/679	0.53	0/917
13	Dy	0.23	0/679	0.53	0/917
13	Dz	0.23	0/679	0.53	0/917
13	EA	0.23	0/679	0.53	0/917
13	EB	0.23	0/679	0.53	0/917
13	EC	0.23	0/679	0.52	0/917
13	ED	0.23	0/679	0.53	0/917
13	EH	0.23	0/679	0.53	0/917
13	EI	0.23	0/679	0.52	0/917
13	EJ	0.23	0/679	0.53	0/917

Mol	Chain	Bond lengths		Bond angles	
		RMSZ	# Z >5	RMSZ	# Z >5
13	EN	0.23	0/679	0.52	0/917
13	EO	0.23	0/679	0.52	0/917
13	EP	0.23	0/679	0.53	0/917
13	ET	0.23	0/679	0.53	0/917
13	EU	0.23	0/679	0.53	0/917
13	EV	0.23	0/679	0.53	0/917
13	EZ	0.23	0/679	0.53	0/917
13	Ed	0.23	0/679	0.53	0/917
13	Ee	0.23	0/679	0.52	0/917
13	Ef	0.23	0/679	0.53	0/917
13	Ej	0.23	0/679	0.53	0/917
13	Ek	0.23	0/679	0.52	0/917
13	El	0.23	0/679	0.53	0/917
13	Ep	0.23	0/679	0.53	0/917
14	B5	0.27	0/2481	0.48	1/3344 (0.0%)
14	Ba	0.27	0/2481	0.48	1/3344 (0.0%)
14	Bg	0.27	0/2481	0.48	1/3344 (0.0%)
14	Bm	0.28	0/2481	0.48	1/3344 (0.0%)
14	Bs	0.27	0/2481	0.48	1/3344 (0.0%)
14	By	0.27	0/2481	0.48	1/3344 (0.0%)
14	C6	0.27	0/2481	0.48	1/3344 (0.0%)
14	CA	0.28	0/2481	0.48	1/3344 (0.0%)
14	CG	0.28	0/2481	0.48	1/3344 (0.0%)
14	CM	0.28	0/2481	0.48	1/3344 (0.0%)
14	CS	0.28	0/2481	0.48	1/3344 (0.0%)
14	CY	0.28	0/2481	0.48	1/3344 (0.0%)
14	Ce	0.28	0/2481	0.48	1/3344 (0.0%)
14	Ck	0.28	0/2481	0.48	1/3344 (0.0%)
14	Cq	0.28	0/2481	0.48	1/3344 (0.0%)
14	Cw	0.28	0/2481	0.48	1/3344 (0.0%)
14	D1	0.28	0/2481	0.48	1/3344 (0.0%)
14	D7	0.28	0/2481	0.48	1/3344 (0.0%)
14	DB	0.28	0/2481	0.48	1/3344 (0.0%)
14	DD	0.28	0/2481	0.48	1/3344 (0.0%)
14	DJ	0.28	0/2481	0.48	1/3344 (0.0%)
14	DQ	0.27	0/2481	0.48	1/3344 (0.0%)
14	DW	0.28	0/2481	0.48	1/3344 (0.0%)
14	Dc	0.28	0/2481	0.48	1/3344 (0.0%)
14	Di	0.28	0/2481	0.48	1/3344 (0.0%)
14	Do	0.28	0/2481	0.48	1/3344 (0.0%)
14	Du	0.28	0/2481	0.48	1/3344 (0.0%)
14	EE	0.28	0/2481	0.48	1/3344 (0.0%)
14	EK	0.28	0/2481	0.48	1/3344 (0.0%)

Mol	Chain	Bond lengths		Bond angles	
		RMSZ	# Z >5	RMSZ	# Z >5
14	EQ	0.27	0/2481	0.48	1/3344 (0.0%)
14	EW	0.27	0/2481	0.48	1/3344 (0.0%)
14	Ea	0.27	0/2481	0.48	1/3344 (0.0%)
14	Eg	0.28	0/2481	0.48	1/3344 (0.0%)
14	Em	0.27	0/2481	0.48	1/3344 (0.0%)
15	B1	0.25	0/2393	0.50	0/3255
15	B7	0.25	0/2393	0.50	0/3255
15	Bc	0.25	0/2393	0.50	0/3255
15	Bi	0.25	0/2393	0.50	0/3255
15	Bo	0.25	0/2393	0.50	0/3255
15	Bu	0.25	0/2393	0.50	0/3255
15	C8	0.25	0/2393	0.50	0/3255
15	CC	0.25	0/2393	0.50	0/3255
15	CI	0.25	0/2393	0.50	0/3255
15	CO	0.25	0/2393	0.50	0/3255
15	CU	0.25	0/2393	0.50	0/3255
15	Ca	0.25	0/2393	0.50	0/3255
15	Cg	0.25	0/2393	0.50	0/3255
15	Cm	0.25	0/2393	0.50	0/3255
15	Cs	0.25	0/2393	0.50	0/3255
15	Cy	0.25	0/2393	0.50	0/3255
15	D3	0.25	0/2393	0.50	0/3255
15	D9	0.25	0/2393	0.50	0/3255
15	DF	0.25	0/2393	0.50	0/3255
15	DL	0.25	0/2393	0.50	0/3255
15	DM	0.25	0/2393	0.50	0/3255
15	DS	0.25	0/2393	0.50	0/3255
15	DY	0.25	0/2393	0.50	0/3255
15	De	0.25	0/2393	0.50	0/3255
15	Dk	0.25	0/2393	0.50	0/3255
15	Dq	0.25	0/2393	0.50	0/3255
15	Dw	0.25	0/2393	0.50	0/3255
15	EG	0.25	0/2393	0.50	0/3255
15	EM	0.25	0/2393	0.50	0/3255
15	ES	0.25	0/2393	0.50	0/3255
15	EY	0.25	0/2393	0.50	0/3255
15	Ec	0.25	0/2393	0.50	0/3255
15	Ei	0.25	0/2393	0.50	0/3255
15	Eo	0.25	0/2393	0.50	0/3255
All	All	0.31	23/585907 (0.0%)	0.53	98/794525 (0.0%)

Chiral center outliers are detected by calculating the chiral volume of a chiral center and verifying if the center is modelled as a planar moiety or with the opposite hand. A planarity outlier is detected

by checking planarity of atoms in a peptide group, atoms in a mainchain group or atoms of a sidechain that are expected to be planar.

Mol	Chain	#Chirality outliers	#Planarity outliers
1	0	0	2
1	1	0	1
1	5	0	2
1	7	0	1
1	8	0	2
1	AF	0	1
1	AI	0	1
1	AK	0	1
1	AL	0	1
1	AM	0	2
1	AN	0	3
1	ZA	0	2
1	ZD	0	1
1	ZE	0	3
3	A0	0	1
3	A6	0	1
3	A7	0	1
3	A9	0	1
5	AA	0	1
5	AB	0	2
5	AD	0	1
6	UI	0	2
6	UJ	0	2
6	UK	0	3
6	UL	0	3
6	UM	0	2
6	UN	0	2
6	UO	0	2
6	UP	0	3
6	WA	0	3
6	WB	0	4
6	WC	0	3
6	WD	0	1
6	WE	0	2
6	WF	0	3
6	WG	0	3
6	WI	0	1
6	WJ	0	3
6	WK	0	2
6	WL	0	2
6	WM	0	1

Continued on next page...

Continued from previous page...

Mol	Chain	#Chirality outliers	#Planarity outliers
6	WN	0	1
6	WO	0	1
6	WP	0	3
6	WQ	0	2
6	WR	0	3
6	WS	0	1
6	WT	0	2
6	WU	0	2
6	WV	0	3
6	WW	0	2
9	Aw	0	2
9	Ay	0	2
10	BD	0	1
10	BF	0	1
11	ZI	0	1
11	ZK	0	1
11	ZO	0	1
11	ZT	0	1
11	ZU	0	1
11	ZW	0	1
11	ZZ	0	1
11	Zd	0	1
11	Ze	0	1
14	B5	0	2
14	Ba	0	2
14	Bg	0	2
14	Bm	0	2
14	Bs	0	2
14	By	0	2
14	C6	0	2
14	CA	0	2
14	CG	0	2
14	CM	0	2
14	CS	0	2
14	CY	0	2
14	Ce	0	2
14	Ck	0	2
14	Cq	0	2
14	Cw	0	2
14	D1	0	2
14	D7	0	2
14	DB	0	2

Continued on next page...

Continued from previous page...

Mol	Chain	#Chirality outliers	#Planarity outliers
14	DD	0	2
14	DJ	0	2
14	DQ	0	2
14	DW	0	2
14	Dc	0	2
14	Di	0	2
14	Do	0	2
14	Du	0	2
14	EE	0	2
14	EK	0	2
14	EQ	0	2
14	EW	0	2
14	Ea	0	2
14	Eg	0	2
14	Em	0	2
All	All	0	181

The worst 5 of 23 bond length outliers are listed below:

Mol	Chain	Res	Type	Atoms	Z	Observed(Å)	Ideal(Å)
11	ZV	140	PRO	CG-CD	-16.11	0.97	1.50
11	ZV	125	PRO	CG-CD	-10.15	1.17	1.50
6	UL	172	PRO	N-CD	-9.55	1.34	1.47
6	UI	172	PRO	N-CD	-9.53	1.34	1.47
6	UM	172	PRO	N-CD	-9.52	1.34	1.47

The worst 5 of 98 bond angle outliers are listed below:

Mol	Chain	Res	Type	Atoms	Z	Observed(°)	Ideal(°)
11	ZV	140	PRO	N-CD-CG	-17.34	77.20	103.20
11	ZR	125	PRO	CA-N-CD	-13.98	91.92	111.50
11	ZY	125	PRO	CA-N-CD	-13.29	92.89	111.50
11	ZV	125	PRO	CA-N-CD	-13.25	92.96	111.50
9	Au	162	PRO	CA-N-CD	-11.97	94.74	111.50

There are no chirality outliers.

5 of 181 planarity outliers are listed below:

Mol	Chain	Res	Type	Group
1	0	36	ARG	Sidechain
1	0	50	ARG	Sidechain

Continued on next page...

Continued from previous page...

Mol	Chain	Res	Type	Group
1	1	36	ARG	Sidechain
1	5	50	ARG	Sidechain
1	5	73	ARG	Sidechain

5.2 Too-close contacts [i](#)

Due to software issues we are unable to calculate clashes - this section is therefore empty.

5.3 Torsion angles [i](#)

5.3.1 Protein backbone [i](#)

In the following table, the Percentiles column shows the percent Ramachandran outliers of the chain as a percentile score with respect to all PDB entries followed by that with respect to all EM entries.

The Analysed column shows the number of residues for which the backbone conformation was analysed, and the total number of residues.

Mol	Chain	Analysed	Favoured	Allowed	Outliers	Percentiles	
1	0	244/260 (94%)	236 (97%)	5 (2%)	3 (1%)	11	44
1	1	248/260 (95%)	238 (96%)	9 (4%)	1 (0%)	30	68
1	2	258/260 (99%)	242 (94%)	14 (5%)	2 (1%)	16	55
1	3	258/260 (99%)	247 (96%)	9 (4%)	2 (1%)	16	55
1	4	258/260 (99%)	245 (95%)	11 (4%)	2 (1%)	16	55
1	5	258/260 (99%)	240 (93%)	15 (6%)	3 (1%)	11	44
1	6	258/260 (99%)	244 (95%)	10 (4%)	4 (2%)	8	38
1	7	258/260 (99%)	244 (95%)	11 (4%)	3 (1%)	11	44
1	8	258/260 (99%)	243 (94%)	12 (5%)	3 (1%)	11	44
1	9	258/260 (99%)	244 (95%)	13 (5%)	1 (0%)	30	68
1	AF	250/260 (96%)	238 (95%)	11 (4%)	1 (0%)	30	68
1	AG	251/260 (96%)	234 (93%)	14 (6%)	3 (1%)	11	44
1	AH	252/260 (97%)	234 (93%)	16 (6%)	2 (1%)	16	55
1	AI	250/260 (96%)	239 (96%)	9 (4%)	2 (1%)	16	55
1	AJ	251/260 (96%)	235 (94%)	10 (4%)	6 (2%)	5	27
1	AK	239/260 (92%)	231 (97%)	7 (3%)	1 (0%)	30	68

Continued on next page...

Continued from previous page...

Mol	Chain	Analysed	Favoured	Allowed	Outliers	Percentiles	
1	AL	244/260 (94%)	229 (94%)	10 (4%)	5 (2%)	6	32
1	AM	244/260 (94%)	234 (96%)	9 (4%)	1 (0%)	30	68
1	AN	244/260 (94%)	239 (98%)	4 (2%)	1 (0%)	30	68
1	ZA	258/260 (99%)	243 (94%)	12 (5%)	3 (1%)	11	44
1	ZB	258/260 (99%)	242 (94%)	13 (5%)	3 (1%)	11	44
1	ZC	258/260 (99%)	242 (94%)	14 (5%)	2 (1%)	16	55
1	ZD	258/260 (99%)	237 (92%)	18 (7%)	3 (1%)	11	44
1	ZE	258/260 (99%)	243 (94%)	14 (5%)	1 (0%)	30	68
2	A	209/232 (90%)	204 (98%)	4 (2%)	1 (0%)	25	64
2	B	209/232 (90%)	204 (98%)	4 (2%)	1 (0%)	25	64
2	C	209/232 (90%)	204 (98%)	4 (2%)	1 (0%)	25	64
2	D	209/232 (90%)	204 (98%)	4 (2%)	1 (0%)	25	64
2	E	209/232 (90%)	204 (98%)	4 (2%)	1 (0%)	25	64
2	F	209/232 (90%)	204 (98%)	4 (2%)	1 (0%)	25	64
2	G	209/232 (90%)	204 (98%)	4 (2%)	1 (0%)	25	64
2	H	209/232 (90%)	204 (98%)	4 (2%)	1 (0%)	25	64
2	I	209/232 (90%)	204 (98%)	4 (2%)	1 (0%)	25	64
2	J	209/232 (90%)	204 (98%)	4 (2%)	1 (0%)	25	64
2	K	209/232 (90%)	204 (98%)	4 (2%)	1 (0%)	25	64
2	L	209/232 (90%)	204 (98%)	4 (2%)	1 (0%)	25	64
2	M	209/232 (90%)	204 (98%)	4 (2%)	1 (0%)	25	64
2	N	209/232 (90%)	204 (98%)	4 (2%)	1 (0%)	25	64
2	O	209/232 (90%)	204 (98%)	4 (2%)	1 (0%)	25	64
2	P	209/232 (90%)	204 (98%)	4 (2%)	1 (0%)	25	64
2	Q	209/232 (90%)	204 (98%)	4 (2%)	1 (0%)	25	64
2	R	209/232 (90%)	204 (98%)	4 (2%)	1 (0%)	25	64
2	S	209/232 (90%)	204 (98%)	4 (2%)	1 (0%)	25	64
2	T	209/232 (90%)	204 (98%)	4 (2%)	1 (0%)	25	64
2	U	209/232 (90%)	204 (98%)	4 (2%)	1 (0%)	25	64
2	V	209/232 (90%)	204 (98%)	4 (2%)	1 (0%)	25	64
2	W	209/232 (90%)	204 (98%)	4 (2%)	1 (0%)	25	64

Continued on next page...

Continued from previous page...

Mol	Chain	Analysed	Favoured	Allowed	Outliers	Percentiles	
2	X	209/232 (90%)	204 (98%)	4 (2%)	1 (0%)	25	64
2	Y	209/232 (90%)	204 (98%)	4 (2%)	1 (0%)	25	64
2	Z	209/232 (90%)	204 (98%)	4 (2%)	1 (0%)	25	64
3	A0	117/138 (85%)	115 (98%)	2 (2%)	0	100	100
3	A6	132/138 (96%)	127 (96%)	4 (3%)	1 (1%)	16	55
3	A7	115/138 (83%)	114 (99%)	1 (1%)	0	100	100
3	A8	119/138 (86%)	116 (98%)	3 (2%)	0	100	100
3	A9	121/138 (88%)	119 (98%)	2 (2%)	0	100	100
4	A1	87/104 (84%)	87 (100%)	0	0	100	100
4	A2	89/104 (86%)	87 (98%)	2 (2%)	0	100	100
4	A3	89/104 (86%)	89 (100%)	0	0	100	100
4	A4	89/104 (86%)	89 (100%)	0	0	100	100
4	A5	88/104 (85%)	88 (100%)	0	0	100	100
4	Az	55/104 (53%)	52 (94%)	3 (6%)	0	100	100
5	AA	246/251 (98%)	238 (97%)	7 (3%)	1 (0%)	30	68
5	AB	247/251 (98%)	241 (98%)	5 (2%)	1 (0%)	30	68
5	AC	248/251 (99%)	233 (94%)	13 (5%)	2 (1%)	16	55
5	AD	248/251 (99%)	235 (95%)	13 (5%)	0	100	100
5	AE	247/251 (98%)	236 (96%)	9 (4%)	2 (1%)	16	55
6	AO	160/560 (29%)	158 (99%)	2 (1%)	0	100	100
6	AP	160/560 (29%)	158 (99%)	2 (1%)	0	100	100
6	AQ	160/560 (29%)	158 (99%)	2 (1%)	0	100	100
6	AR	160/560 (29%)	158 (99%)	2 (1%)	0	100	100
6	AS	160/560 (29%)	158 (99%)	2 (1%)	0	100	100
6	AT	160/560 (29%)	158 (99%)	2 (1%)	0	100	100
6	AU	160/560 (29%)	158 (99%)	2 (1%)	0	100	100
6	AV	160/560 (29%)	158 (99%)	2 (1%)	0	100	100
6	AW	160/560 (29%)	158 (99%)	2 (1%)	0	100	100
6	AX	160/560 (29%)	158 (99%)	2 (1%)	0	100	100
6	AY	160/560 (29%)	158 (99%)	2 (1%)	0	100	100
6	AZ	160/560 (29%)	158 (99%)	2 (1%)	0	100	100

Continued on next page...

Continued from previous page...

Mol	Chain	Analysed	Favoured	Allowed	Outliers	Percentiles	
6	Aa	160/560 (29%)	158 (99%)	2 (1%)	0	100	100
6	Ac	160/560 (29%)	158 (99%)	2 (1%)	0	100	100
6	Ad	160/560 (29%)	158 (99%)	2 (1%)	0	100	100
6	Ae	160/560 (29%)	158 (99%)	2 (1%)	0	100	100
6	Af	160/560 (29%)	158 (99%)	2 (1%)	0	100	100
6	Ag	160/560 (29%)	158 (99%)	2 (1%)	0	100	100
6	Ah	160/560 (29%)	158 (99%)	2 (1%)	0	100	100
6	Ai	160/560 (29%)	158 (99%)	2 (1%)	0	100	100
6	Aj	160/560 (29%)	158 (99%)	2 (1%)	0	100	100
6	Ak	160/560 (29%)	158 (99%)	2 (1%)	0	100	100
6	Al	160/560 (29%)	158 (99%)	2 (1%)	0	100	100
6	Am	160/560 (29%)	158 (99%)	2 (1%)	0	100	100
6	An	160/560 (29%)	158 (99%)	2 (1%)	0	100	100
6	Ao	160/560 (29%)	158 (99%)	2 (1%)	0	100	100
6	Ap	160/560 (29%)	158 (99%)	2 (1%)	0	100	100
6	B6	25/560 (4%)	24 (96%)	1 (4%)	0	100	100
6	BG	11/560 (2%)	9 (82%)	2 (18%)	0	100	100
6	BH	14/560 (2%)	12 (86%)	2 (14%)	0	100	100
6	BI	18/560 (3%)	18 (100%)	0	0	100	100
6	BJ	14/560 (2%)	14 (100%)	0	0	100	100
6	BK	19/560 (3%)	17 (90%)	2 (10%)	0	100	100
6	BL	14/560 (2%)	13 (93%)	1 (7%)	0	100	100
6	BM	19/560 (3%)	19 (100%)	0	0	100	100
6	BN	14/560 (2%)	14 (100%)	0	0	100	100
6	BO	18/560 (3%)	18 (100%)	0	0	100	100
6	BP	14/560 (2%)	14 (100%)	0	0	100	100
6	BQ	19/560 (3%)	19 (100%)	0	0	100	100
6	BR	160/560 (29%)	158 (99%)	2 (1%)	0	100	100
6	BS	160/560 (29%)	158 (99%)	2 (1%)	0	100	100
6	BT	160/560 (29%)	158 (99%)	2 (1%)	0	100	100
6	BU	160/560 (29%)	158 (99%)	2 (1%)	0	100	100

Continued on next page...

Continued from previous page...

Mol	Chain	Analysed	Favoured	Allowed	Outliers	Percentiles	
6	BV	160/560 (29%)	158 (99%)	2 (1%)	0	100	100
6	BW	160/560 (29%)	158 (99%)	2 (1%)	0	100	100
6	BX	160/560 (29%)	158 (99%)	2 (1%)	0	100	100
6	Bb	25/560 (4%)	24 (96%)	1 (4%)	0	100	100
6	Bh	25/560 (4%)	24 (96%)	1 (4%)	0	100	100
6	Bn	25/560 (4%)	24 (96%)	1 (4%)	0	100	100
6	Bt	25/560 (4%)	24 (96%)	1 (4%)	0	100	100
6	Bz	25/560 (4%)	24 (96%)	1 (4%)	0	100	100
6	C3	25/560 (4%)	24 (96%)	1 (4%)	0	100	100
6	C7	25/560 (4%)	24 (96%)	1 (4%)	0	100	100
6	CB	25/560 (4%)	24 (96%)	1 (4%)	0	100	100
6	CH	25/560 (4%)	24 (96%)	1 (4%)	0	100	100
6	CN	25/560 (4%)	24 (96%)	1 (4%)	0	100	100
6	CT	25/560 (4%)	24 (96%)	1 (4%)	0	100	100
6	CZ	25/560 (4%)	24 (96%)	1 (4%)	0	100	100
6	Cf	25/560 (4%)	24 (96%)	1 (4%)	0	100	100
6	Cl	25/560 (4%)	24 (96%)	1 (4%)	0	100	100
6	Cr	25/560 (4%)	24 (96%)	1 (4%)	0	100	100
6	Cx	25/560 (4%)	24 (96%)	1 (4%)	0	100	100
6	D2	25/560 (4%)	24 (96%)	1 (4%)	0	100	100
6	D8	25/560 (4%)	24 (96%)	1 (4%)	0	100	100
6	DE	25/560 (4%)	24 (96%)	1 (4%)	0	100	100
6	DK	25/560 (4%)	24 (96%)	1 (4%)	0	100	100
6	DR	25/560 (4%)	24 (96%)	1 (4%)	0	100	100
6	DX	25/560 (4%)	24 (96%)	1 (4%)	0	100	100
6	Dd	25/560 (4%)	24 (96%)	1 (4%)	0	100	100
6	Dj	25/560 (4%)	24 (96%)	1 (4%)	0	100	100
6	Dp	25/560 (4%)	24 (96%)	1 (4%)	0	100	100
6	Dv	25/560 (4%)	24 (96%)	1 (4%)	0	100	100
6	EF	25/560 (4%)	24 (96%)	1 (4%)	0	100	100
6	EL	25/560 (4%)	24 (96%)	1 (4%)	0	100	100

Continued on next page...

Continued from previous page...

Mol	Chain	Analysed	Favoured	Allowed	Outliers	Percentiles	
6	ER	25/560 (4%)	24 (96%)	1 (4%)	0	100	100
6	EX	25/560 (4%)	24 (96%)	1 (4%)	0	100	100
6	Eb	25/560 (4%)	24 (96%)	1 (4%)	0	100	100
6	Eh	25/560 (4%)	24 (96%)	1 (4%)	0	100	100
6	En	25/560 (4%)	24 (96%)	1 (4%)	0	100	100
6	UI	151/560 (27%)	146 (97%)	3 (2%)	2 (1%)	10	43
6	UJ	151/560 (27%)	146 (97%)	3 (2%)	2 (1%)	10	43
6	UK	151/560 (27%)	146 (97%)	3 (2%)	2 (1%)	10	43
6	UL	151/560 (27%)	142 (94%)	7 (5%)	2 (1%)	10	43
6	UM	151/560 (27%)	146 (97%)	3 (2%)	2 (1%)	10	43
6	UN	151/560 (27%)	146 (97%)	3 (2%)	2 (1%)	10	43
6	UO	151/560 (27%)	146 (97%)	3 (2%)	2 (1%)	10	43
6	UP	151/560 (27%)	146 (97%)	3 (2%)	2 (1%)	10	43
6	WA	111/560 (20%)	99 (89%)	9 (8%)	3 (3%)	4	25
6	WB	109/560 (20%)	94 (86%)	10 (9%)	5 (5%)	2	17
6	WC	106/560 (19%)	96 (91%)	9 (8%)	1 (1%)	14	52
6	WD	108/560 (19%)	99 (92%)	4 (4%)	5 (5%)	2	17
6	WE	110/560 (20%)	98 (89%)	8 (7%)	4 (4%)	3	20
6	WF	109/560 (20%)	98 (90%)	8 (7%)	3 (3%)	4	24
6	WG	110/560 (20%)	98 (89%)	10 (9%)	2 (2%)	7	35
6	WH	93/560 (17%)	86 (92%)	5 (5%)	2 (2%)	5	29
6	WI	93/560 (17%)	82 (88%)	5 (5%)	6 (6%)	1	12
6	WJ	97/560 (17%)	89 (92%)	7 (7%)	1 (1%)	13	49
6	WK	96/560 (17%)	84 (88%)	9 (9%)	3 (3%)	3	22
6	WL	81/560 (14%)	75 (93%)	4 (5%)	2 (2%)	4	26
6	WM	78/560 (14%)	72 (92%)	4 (5%)	2 (3%)	4	26
6	WN	80/560 (14%)	75 (94%)	2 (2%)	3 (4%)	2	19
6	WO	94/560 (17%)	85 (90%)	7 (7%)	2 (2%)	5	30
6	WP	98/560 (18%)	87 (89%)	6 (6%)	5 (5%)	1	15
6	WQ	109/560 (20%)	100 (92%)	5 (5%)	4 (4%)	2	20
6	WR	109/560 (20%)	94 (86%)	8 (7%)	7 (6%)	1	13

Continued on next page...

Continued from previous page...

Mol	Chain	Analysed	Favoured	Allowed	Outliers	Percentiles	
6	WS	109/560 (20%)	96 (88%)	7 (6%)	6 (6%)	1	15
6	WT	109/560 (20%)	97 (89%)	5 (5%)	7 (6%)	1	13
6	WU	110/560 (20%)	101 (92%)	8 (7%)	1 (1%)	14	52
6	WV	108/560 (19%)	97 (90%)	9 (8%)	2 (2%)	6	32
6	WW	109/560 (20%)	95 (87%)	9 (8%)	5 (5%)	2	17
7	Ab	87/89 (98%)	81 (93%)	4 (5%)	2 (2%)	5	28
7	Aq	87/89 (98%)	86 (99%)	1 (1%)	0	100	100
7	Ar	87/89 (98%)	86 (99%)	1 (1%)	0	100	100
7	As	87/89 (98%)	85 (98%)	2 (2%)	0	100	100
8	At	251/264 (95%)	233 (93%)	16 (6%)	2 (1%)	16	55
9	Au	205/245 (84%)	197 (96%)	8 (4%)	0	100	100
9	Av	207/245 (84%)	199 (96%)	6 (3%)	2 (1%)	13	49
9	Aw	206/245 (84%)	201 (98%)	5 (2%)	0	100	100
9	Ax	206/245 (84%)	199 (97%)	6 (3%)	1 (0%)	25	64
9	Ay	207/245 (84%)	192 (93%)	10 (5%)	5 (2%)	5	27
10	BA	131/134 (98%)	122 (93%)	9 (7%)	0	100	100
10	BB	130/134 (97%)	123 (95%)	7 (5%)	0	100	100
10	BC	131/134 (98%)	124 (95%)	7 (5%)	0	100	100
10	BD	131/134 (98%)	121 (92%)	7 (5%)	3 (2%)	5	28
10	BE	129/134 (96%)	123 (95%)	5 (4%)	1 (1%)	16	55
10	BF	131/134 (98%)	124 (95%)	7 (5%)	0	100	100
11	ZF	399/403 (99%)	387 (97%)	12 (3%)	0	100	100
11	ZG	399/403 (99%)	388 (97%)	10 (2%)	1 (0%)	37	73
11	ZH	399/403 (99%)	385 (96%)	14 (4%)	0	100	100
11	ZI	399/403 (99%)	387 (97%)	10 (2%)	2 (0%)	25	64
11	ZJ	399/403 (99%)	387 (97%)	12 (3%)	0	100	100
11	ZK	399/403 (99%)	387 (97%)	11 (3%)	1 (0%)	37	73
11	ZL	399/403 (99%)	389 (98%)	9 (2%)	1 (0%)	37	73
11	ZM	399/403 (99%)	388 (97%)	11 (3%)	0	100	100
11	ZN	399/403 (99%)	388 (97%)	11 (3%)	0	100	100
11	ZO	399/403 (99%)	381 (96%)	15 (4%)	3 (1%)	16	55

Continued on next page...

Continued from previous page...

Mol	Chain	Analysed	Favoured	Allowed	Outliers	Percentiles	
11	ZP	399/403 (99%)	386 (97%)	12 (3%)	1 (0%)	37	73
11	ZQ	399/403 (99%)	389 (98%)	10 (2%)	0	100	100
11	ZR	399/403 (99%)	391 (98%)	8 (2%)	0	100	100
11	ZS	399/403 (99%)	390 (98%)	9 (2%)	0	100	100
11	ZT	399/403 (99%)	389 (98%)	10 (2%)	0	100	100
11	ZU	399/403 (99%)	387 (97%)	12 (3%)	0	100	100
11	ZV	399/403 (99%)	390 (98%)	9 (2%)	0	100	100
11	ZW	399/403 (99%)	380 (95%)	18 (4%)	1 (0%)	37	73
11	ZX	399/403 (99%)	388 (97%)	11 (3%)	0	100	100
11	ZY	399/403 (99%)	385 (96%)	14 (4%)	0	100	100
11	ZZ	399/403 (99%)	389 (98%)	10 (2%)	0	100	100
11	Za	399/403 (99%)	386 (97%)	12 (3%)	1 (0%)	37	73
11	Zb	399/403 (99%)	392 (98%)	7 (2%)	0	100	100
11	Zc	399/403 (99%)	390 (98%)	9 (2%)	0	100	100
11	Zd	399/403 (99%)	384 (96%)	15 (4%)	0	100	100
11	Ze	399/403 (99%)	385 (96%)	13 (3%)	1 (0%)	37	73
11	Zf	399/403 (99%)	386 (97%)	13 (3%)	0	100	100
11	Zg	399/403 (99%)	383 (96%)	16 (4%)	0	100	100
11	Zh	399/403 (99%)	391 (98%)	8 (2%)	0	100	100
12	a	297/365 (81%)	289 (97%)	8 (3%)	0	100	100
12	b	297/365 (81%)	289 (97%)	8 (3%)	0	100	100
12	c	297/365 (81%)	289 (97%)	8 (3%)	0	100	100
12	d	297/365 (81%)	289 (97%)	8 (3%)	0	100	100
12	e	297/365 (81%)	289 (97%)	8 (3%)	0	100	100
12	f	297/365 (81%)	288 (97%)	9 (3%)	0	100	100
12	g	297/365 (81%)	288 (97%)	9 (3%)	0	100	100
12	h	297/365 (81%)	288 (97%)	9 (3%)	0	100	100
12	i	297/365 (81%)	288 (97%)	9 (3%)	0	100	100
12	j	297/365 (81%)	288 (97%)	9 (3%)	0	100	100
12	k	297/365 (81%)	288 (97%)	9 (3%)	0	100	100
12	l	297/365 (81%)	289 (97%)	8 (3%)	0	100	100

Continued on next page...

Continued from previous page...

Mol	Chain	Analysed	Favoured	Allowed	Outliers	Percentiles	
12	m	297/365 (81%)	288 (97%)	9 (3%)	0	100	100
12	n	297/365 (81%)	289 (97%)	8 (3%)	0	100	100
12	o	297/365 (81%)	288 (97%)	9 (3%)	0	100	100
12	p	297/365 (81%)	288 (97%)	9 (3%)	0	100	100
12	q	297/365 (81%)	289 (97%)	8 (3%)	0	100	100
12	r	297/365 (81%)	289 (97%)	8 (3%)	0	100	100
12	s	297/365 (81%)	289 (97%)	8 (3%)	0	100	100
12	t	297/365 (81%)	289 (97%)	8 (3%)	0	100	100
12	u	297/365 (81%)	288 (97%)	9 (3%)	0	100	100
12	v	297/365 (81%)	288 (97%)	9 (3%)	0	100	100
12	w	297/365 (81%)	289 (97%)	8 (3%)	0	100	100
12	x	297/365 (81%)	288 (97%)	9 (3%)	0	100	100
12	y	297/365 (81%)	288 (97%)	9 (3%)	0	100	100
12	z	297/365 (81%)	289 (97%)	8 (3%)	0	100	100
13	B0	85/137 (62%)	79 (93%)	5 (6%)	1 (1%)	11	44
13	B2	85/137 (62%)	79 (93%)	5 (6%)	1 (1%)	11	44
13	B3	85/137 (62%)	79 (93%)	5 (6%)	1 (1%)	11	44
13	B4	85/137 (62%)	79 (93%)	5 (6%)	1 (1%)	11	44
13	B8	85/137 (62%)	79 (93%)	5 (6%)	1 (1%)	11	44
13	B9	85/137 (62%)	79 (93%)	5 (6%)	1 (1%)	11	44
13	BY	85/137 (62%)	79 (93%)	5 (6%)	1 (1%)	11	44
13	BZ	85/137 (62%)	79 (93%)	5 (6%)	1 (1%)	11	44
13	Bd	85/137 (62%)	79 (93%)	5 (6%)	1 (1%)	11	44
13	Be	85/137 (62%)	79 (93%)	5 (6%)	1 (1%)	11	44
13	Bf	85/137 (62%)	79 (93%)	5 (6%)	1 (1%)	11	44
13	Bj	85/137 (62%)	79 (93%)	5 (6%)	1 (1%)	11	44
13	Bk	85/137 (62%)	79 (93%)	5 (6%)	1 (1%)	11	44
13	Bl	85/137 (62%)	79 (93%)	5 (6%)	1 (1%)	11	44
13	Bp	85/137 (62%)	79 (93%)	5 (6%)	1 (1%)	11	44
13	Bq	85/137 (62%)	79 (93%)	5 (6%)	1 (1%)	11	44
13	Br	85/137 (62%)	79 (93%)	5 (6%)	1 (1%)	11	44

Continued on next page...

Continued from previous page...

Mol	Chain	Analysed	Favoured	Allowed	Outliers	Percentiles	
13	Bv	85/137 (62%)	79 (93%)	5 (6%)	1 (1%)	11	44
13	Bw	85/137 (62%)	79 (93%)	5 (6%)	1 (1%)	11	44
13	Bx	85/137 (62%)	79 (93%)	5 (6%)	1 (1%)	11	44
13	C0	85/137 (62%)	79 (93%)	5 (6%)	1 (1%)	11	44
13	C1	85/137 (62%)	79 (93%)	5 (6%)	1 (1%)	11	44
13	C2	85/137 (62%)	79 (93%)	5 (6%)	1 (1%)	11	44
13	C4	85/137 (62%)	79 (93%)	5 (6%)	1 (1%)	11	44
13	C5	85/137 (62%)	79 (93%)	5 (6%)	1 (1%)	11	44
13	C9	85/137 (62%)	79 (93%)	5 (6%)	1 (1%)	11	44
13	CD	85/137 (62%)	79 (93%)	5 (6%)	1 (1%)	11	44
13	CE	85/137 (62%)	79 (93%)	5 (6%)	1 (1%)	11	44
13	CF	85/137 (62%)	79 (93%)	5 (6%)	1 (1%)	11	44
13	CJ	85/137 (62%)	79 (93%)	5 (6%)	1 (1%)	11	44
13	CK	85/137 (62%)	79 (93%)	5 (6%)	1 (1%)	11	44
13	CL	85/137 (62%)	79 (93%)	5 (6%)	1 (1%)	11	44
13	CP	85/137 (62%)	79 (93%)	5 (6%)	1 (1%)	11	44
13	CQ	85/137 (62%)	79 (93%)	5 (6%)	1 (1%)	11	44
13	CR	85/137 (62%)	79 (93%)	5 (6%)	1 (1%)	11	44
13	CV	85/137 (62%)	79 (93%)	5 (6%)	1 (1%)	11	44
13	CW	85/137 (62%)	79 (93%)	5 (6%)	1 (1%)	11	44
13	CX	85/137 (62%)	79 (93%)	5 (6%)	1 (1%)	11	44
13	Cb	85/137 (62%)	79 (93%)	5 (6%)	1 (1%)	11	44
13	Cc	85/137 (62%)	79 (93%)	5 (6%)	1 (1%)	11	44
13	Cd	85/137 (62%)	79 (93%)	5 (6%)	1 (1%)	11	44
13	Ch	85/137 (62%)	79 (93%)	5 (6%)	1 (1%)	11	44
13	Ci	85/137 (62%)	79 (93%)	5 (6%)	1 (1%)	11	44
13	Cj	85/137 (62%)	79 (93%)	5 (6%)	1 (1%)	11	44
13	Cn	85/137 (62%)	79 (93%)	5 (6%)	1 (1%)	11	44
13	Co	85/137 (62%)	79 (93%)	5 (6%)	1 (1%)	11	44
13	Cp	85/137 (62%)	79 (93%)	5 (6%)	1 (1%)	11	44
13	Ct	85/137 (62%)	79 (93%)	5 (6%)	1 (1%)	11	44

Continued on next page...

Continued from previous page...

Mol	Chain	Analysed	Favoured	Allowed	Outliers	Percentiles	
13	Cu	85/137 (62%)	79 (93%)	5 (6%)	1 (1%)	11	44
13	Cv	85/137 (62%)	79 (93%)	5 (6%)	1 (1%)	11	44
13	Cz	85/137 (62%)	79 (93%)	5 (6%)	1 (1%)	11	44
13	D0	85/137 (62%)	79 (93%)	5 (6%)	1 (1%)	11	44
13	D4	85/137 (62%)	79 (93%)	5 (6%)	1 (1%)	11	44
13	D5	85/137 (62%)	79 (93%)	5 (6%)	1 (1%)	11	44
13	D6	85/137 (62%)	79 (93%)	5 (6%)	1 (1%)	11	44
13	DA	85/137 (62%)	79 (93%)	5 (6%)	1 (1%)	11	44
13	DC	85/137 (62%)	79 (93%)	5 (6%)	1 (1%)	11	44
13	DG	85/137 (62%)	79 (93%)	5 (6%)	1 (1%)	11	44
13	DH	85/137 (62%)	79 (93%)	5 (6%)	1 (1%)	11	44
13	DI	85/137 (62%)	79 (93%)	5 (6%)	1 (1%)	11	44
13	DN	85/137 (62%)	79 (93%)	5 (6%)	1 (1%)	11	44
13	DO	85/137 (62%)	79 (93%)	5 (6%)	1 (1%)	11	44
13	DP	85/137 (62%)	79 (93%)	5 (6%)	1 (1%)	11	44
13	DT	85/137 (62%)	79 (93%)	5 (6%)	1 (1%)	11	44
13	DU	85/137 (62%)	79 (93%)	5 (6%)	1 (1%)	11	44
13	DV	85/137 (62%)	79 (93%)	5 (6%)	1 (1%)	11	44
13	DZ	85/137 (62%)	79 (93%)	5 (6%)	1 (1%)	11	44
13	Da	85/137 (62%)	79 (93%)	5 (6%)	1 (1%)	11	44
13	Db	85/137 (62%)	79 (93%)	5 (6%)	1 (1%)	11	44
13	Df	85/137 (62%)	79 (93%)	5 (6%)	1 (1%)	11	44
13	Dg	85/137 (62%)	79 (93%)	5 (6%)	1 (1%)	11	44
13	Dh	85/137 (62%)	79 (93%)	5 (6%)	1 (1%)	11	44
13	DI	85/137 (62%)	79 (93%)	5 (6%)	1 (1%)	11	44
13	Dm	85/137 (62%)	79 (93%)	5 (6%)	1 (1%)	11	44
13	Dn	85/137 (62%)	79 (93%)	5 (6%)	1 (1%)	11	44
13	Dr	85/137 (62%)	79 (93%)	5 (6%)	1 (1%)	11	44
13	Ds	85/137 (62%)	79 (93%)	5 (6%)	1 (1%)	11	44
13	Dt	85/137 (62%)	79 (93%)	5 (6%)	1 (1%)	11	44
13	Dx	85/137 (62%)	79 (93%)	5 (6%)	1 (1%)	11	44

Continued on next page...

Continued from previous page...

Mol	Chain	Analysed	Favoured	Allowed	Outliers	Percentiles	
13	Dy	85/137 (62%)	79 (93%)	5 (6%)	1 (1%)	11	44
13	Dz	85/137 (62%)	79 (93%)	5 (6%)	1 (1%)	11	44
13	EA	85/137 (62%)	79 (93%)	5 (6%)	1 (1%)	11	44
13	EB	85/137 (62%)	79 (93%)	5 (6%)	1 (1%)	11	44
13	EC	85/137 (62%)	79 (93%)	5 (6%)	1 (1%)	11	44
13	ED	85/137 (62%)	79 (93%)	5 (6%)	1 (1%)	11	44
13	EH	85/137 (62%)	79 (93%)	5 (6%)	1 (1%)	11	44
13	EI	85/137 (62%)	79 (93%)	5 (6%)	1 (1%)	11	44
13	EJ	85/137 (62%)	79 (93%)	5 (6%)	1 (1%)	11	44
13	EN	85/137 (62%)	79 (93%)	5 (6%)	1 (1%)	11	44
13	EO	85/137 (62%)	79 (93%)	5 (6%)	1 (1%)	11	44
13	EP	85/137 (62%)	79 (93%)	5 (6%)	1 (1%)	11	44
13	ET	85/137 (62%)	79 (93%)	5 (6%)	1 (1%)	11	44
13	EU	85/137 (62%)	79 (93%)	5 (6%)	1 (1%)	11	44
13	EV	85/137 (62%)	79 (93%)	5 (6%)	1 (1%)	11	44
13	EZ	85/137 (62%)	79 (93%)	5 (6%)	1 (1%)	11	44
13	Ed	85/137 (62%)	79 (93%)	5 (6%)	1 (1%)	11	44
13	Ee	85/137 (62%)	79 (93%)	5 (6%)	1 (1%)	11	44
13	Ef	85/137 (62%)	79 (93%)	5 (6%)	1 (1%)	11	44
13	Ej	85/137 (62%)	79 (93%)	5 (6%)	1 (1%)	11	44
13	Ek	85/137 (62%)	79 (93%)	5 (6%)	1 (1%)	11	44
13	El	85/137 (62%)	79 (93%)	5 (6%)	1 (1%)	11	44
13	Ep	85/137 (62%)	79 (93%)	5 (6%)	1 (1%)	11	44
14	B5	311/331 (94%)	302 (97%)	7 (2%)	2 (1%)	22	60
14	Ba	311/331 (94%)	302 (97%)	7 (2%)	2 (1%)	22	60
14	Bg	311/331 (94%)	302 (97%)	7 (2%)	2 (1%)	22	60
14	Bm	311/331 (94%)	302 (97%)	7 (2%)	2 (1%)	22	60
14	Bs	311/331 (94%)	302 (97%)	7 (2%)	2 (1%)	22	60
14	By	311/331 (94%)	302 (97%)	7 (2%)	2 (1%)	22	60
14	C6	311/331 (94%)	302 (97%)	7 (2%)	2 (1%)	22	60
14	CA	311/331 (94%)	302 (97%)	7 (2%)	2 (1%)	22	60

Continued on next page...

Continued from previous page...

Mol	Chain	Analysed	Favoured	Allowed	Outliers	Percentiles	
14	CG	311/331 (94%)	302 (97%)	7 (2%)	2 (1%)	22	60
14	CM	311/331 (94%)	302 (97%)	7 (2%)	2 (1%)	22	60
14	CS	311/331 (94%)	302 (97%)	7 (2%)	2 (1%)	22	60
14	CY	311/331 (94%)	302 (97%)	7 (2%)	2 (1%)	22	60
14	Ce	311/331 (94%)	302 (97%)	7 (2%)	2 (1%)	22	60
14	Ck	311/331 (94%)	302 (97%)	7 (2%)	2 (1%)	22	60
14	Cq	311/331 (94%)	302 (97%)	7 (2%)	2 (1%)	22	60
14	Cw	311/331 (94%)	302 (97%)	7 (2%)	2 (1%)	22	60
14	D1	311/331 (94%)	302 (97%)	7 (2%)	2 (1%)	22	60
14	D7	311/331 (94%)	302 (97%)	7 (2%)	2 (1%)	22	60
14	DB	311/331 (94%)	302 (97%)	7 (2%)	2 (1%)	22	60
14	DD	311/331 (94%)	302 (97%)	7 (2%)	2 (1%)	22	60
14	DJ	311/331 (94%)	302 (97%)	7 (2%)	2 (1%)	22	60
14	DQ	311/331 (94%)	302 (97%)	7 (2%)	2 (1%)	22	60
14	DW	311/331 (94%)	302 (97%)	7 (2%)	2 (1%)	22	60
14	Dc	311/331 (94%)	302 (97%)	7 (2%)	2 (1%)	22	60
14	Di	311/331 (94%)	302 (97%)	7 (2%)	2 (1%)	22	60
14	Do	311/331 (94%)	302 (97%)	7 (2%)	2 (1%)	22	60
14	Du	311/331 (94%)	302 (97%)	7 (2%)	2 (1%)	22	60
14	EE	311/331 (94%)	302 (97%)	7 (2%)	2 (1%)	22	60
14	EK	311/331 (94%)	302 (97%)	7 (2%)	2 (1%)	22	60
14	EQ	311/331 (94%)	302 (97%)	7 (2%)	2 (1%)	22	60
14	EW	311/331 (94%)	302 (97%)	7 (2%)	2 (1%)	22	60
14	Ea	311/331 (94%)	302 (97%)	7 (2%)	2 (1%)	22	60
14	Eg	311/331 (94%)	302 (97%)	7 (2%)	2 (1%)	22	60
14	Em	311/331 (94%)	302 (97%)	7 (2%)	2 (1%)	22	60
15	B1	287/334 (86%)	276 (96%)	9 (3%)	2 (1%)	19	57
15	B7	287/334 (86%)	276 (96%)	9 (3%)	2 (1%)	19	57
15	Bc	287/334 (86%)	276 (96%)	9 (3%)	2 (1%)	19	57
15	Bi	287/334 (86%)	276 (96%)	9 (3%)	2 (1%)	19	57
15	Bo	287/334 (86%)	276 (96%)	9 (3%)	2 (1%)	19	57

Continued on next page...

Continued from previous page...

Mol	Chain	Analysed	Favoured	Allowed	Outliers	Percentiles	
15	Bu	287/334 (86%)	276 (96%)	9 (3%)	2 (1%)	19	57
15	C8	287/334 (86%)	276 (96%)	9 (3%)	2 (1%)	19	57
15	CC	287/334 (86%)	276 (96%)	9 (3%)	2 (1%)	19	57
15	CI	287/334 (86%)	276 (96%)	9 (3%)	2 (1%)	19	57
15	CO	287/334 (86%)	276 (96%)	9 (3%)	2 (1%)	19	57
15	CU	287/334 (86%)	276 (96%)	9 (3%)	2 (1%)	19	57
15	Ca	287/334 (86%)	276 (96%)	9 (3%)	2 (1%)	19	57
15	Cg	287/334 (86%)	276 (96%)	9 (3%)	2 (1%)	19	57
15	Cm	287/334 (86%)	276 (96%)	9 (3%)	2 (1%)	19	57
15	Cs	287/334 (86%)	276 (96%)	9 (3%)	2 (1%)	19	57
15	Cy	287/334 (86%)	276 (96%)	9 (3%)	2 (1%)	19	57
15	D3	287/334 (86%)	276 (96%)	9 (3%)	2 (1%)	19	57
15	D9	287/334 (86%)	276 (96%)	9 (3%)	2 (1%)	19	57
15	DF	287/334 (86%)	276 (96%)	9 (3%)	2 (1%)	19	57
15	DL	287/334 (86%)	276 (96%)	9 (3%)	2 (1%)	19	57
15	DM	287/334 (86%)	276 (96%)	9 (3%)	2 (1%)	19	57
15	DS	287/334 (86%)	276 (96%)	9 (3%)	2 (1%)	19	57
15	DY	287/334 (86%)	276 (96%)	9 (3%)	2 (1%)	19	57
15	De	287/334 (86%)	276 (96%)	9 (3%)	2 (1%)	19	57
15	Dk	287/334 (86%)	276 (96%)	9 (3%)	2 (1%)	19	57
15	Dq	287/334 (86%)	276 (96%)	9 (3%)	2 (1%)	19	57
15	Dw	287/334 (86%)	276 (96%)	9 (3%)	2 (1%)	19	57
15	EG	287/334 (86%)	276 (96%)	9 (3%)	2 (1%)	19	57
15	EM	287/334 (86%)	276 (96%)	9 (3%)	2 (1%)	19	57
15	ES	287/334 (86%)	276 (96%)	9 (3%)	2 (1%)	19	57
15	EY	287/334 (86%)	276 (96%)	9 (3%)	2 (1%)	19	57
15	Ec	287/334 (86%)	276 (96%)	9 (3%)	2 (1%)	19	57
15	Ei	287/334 (86%)	276 (96%)	9 (3%)	2 (1%)	19	57
15	Eo	287/334 (86%)	276 (96%)	9 (3%)	2 (1%)	19	57
All	All	74558/136851 (54%)	71664 (96%)	2440 (3%)	454 (1%)	24	60

5 of 454 Ramachandran outliers are listed below:

Mol	Chain	Res	Type
1	2	209	ASN
1	4	140	ILE
1	5	209	ASN
1	6	139	ALA
1	8	209	ASN

5.3.2 Protein sidechains [i](#)

In the following table, the Percentiles column shows the percent sidechain outliers of the chain as a percentile score with respect to all PDB entries followed by that with respect to all EM entries.

The Analysed column shows the number of residues for which the sidechain conformation was analysed, and the total number of residues.

Mol	Chain	Analysed	Rotameric	Outliers	Percentiles	
1	0	205/215 (95%)	198 (97%)	7 (3%)	32	51
1	1	209/215 (97%)	201 (96%)	8 (4%)	28	49
1	2	215/215 (100%)	212 (99%)	3 (1%)	62	75
1	3	215/215 (100%)	212 (99%)	3 (1%)	62	75
1	4	215/215 (100%)	209 (97%)	6 (3%)	38	57
1	5	215/215 (100%)	210 (98%)	5 (2%)	45	64
1	6	215/215 (100%)	210 (98%)	5 (2%)	45	64
1	7	215/215 (100%)	214 (100%)	1 (0%)	86	89
1	8	215/215 (100%)	210 (98%)	5 (2%)	45	64
1	9	215/215 (100%)	212 (99%)	3 (1%)	62	75
1	AF	209/215 (97%)	203 (97%)	6 (3%)	37	56
1	AG	210/215 (98%)	201 (96%)	9 (4%)	25	46
1	AH	211/215 (98%)	199 (94%)	12 (6%)	17	38
1	AI	209/215 (97%)	198 (95%)	11 (5%)	19	40
1	AJ	210/215 (98%)	199 (95%)	11 (5%)	19	40
1	AK	200/215 (93%)	195 (98%)	5 (2%)	42	61
1	AL	205/215 (95%)	197 (96%)	8 (4%)	27	48
1	AM	205/215 (95%)	197 (96%)	8 (4%)	27	48
1	AN	205/215 (95%)	200 (98%)	5 (2%)	44	62
1	ZA	215/215 (100%)	213 (99%)	2 (1%)	75	83

Continued on next page...

Continued from previous page...

Mol	Chain	Analysed	Rotameric	Outliers	Percentiles	
1	ZB	215/215 (100%)	209 (97%)	6 (3%)	38	57
1	ZC	215/215 (100%)	212 (99%)	3 (1%)	62	75
1	ZD	215/215 (100%)	211 (98%)	4 (2%)	52	69
1	ZE	215/215 (100%)	210 (98%)	5 (2%)	45	64
2	A	170/186 (91%)	164 (96%)	6 (4%)	31	51
2	B	170/186 (91%)	164 (96%)	6 (4%)	31	51
2	C	170/186 (91%)	164 (96%)	6 (4%)	31	51
2	D	170/186 (91%)	164 (96%)	6 (4%)	31	51
2	E	170/186 (91%)	164 (96%)	6 (4%)	31	51
2	F	170/186 (91%)	164 (96%)	6 (4%)	31	51
2	G	170/186 (91%)	164 (96%)	6 (4%)	31	51
2	H	170/186 (91%)	164 (96%)	6 (4%)	31	51
2	I	170/186 (91%)	164 (96%)	6 (4%)	31	51
2	J	170/186 (91%)	164 (96%)	6 (4%)	31	51
2	K	170/186 (91%)	164 (96%)	6 (4%)	31	51
2	L	170/186 (91%)	164 (96%)	6 (4%)	31	51
2	M	170/186 (91%)	164 (96%)	6 (4%)	31	51
2	N	170/186 (91%)	164 (96%)	6 (4%)	31	51
2	O	170/186 (91%)	164 (96%)	6 (4%)	31	51
2	P	170/186 (91%)	164 (96%)	6 (4%)	31	51
2	Q	170/186 (91%)	164 (96%)	6 (4%)	31	51
2	R	170/186 (91%)	164 (96%)	6 (4%)	31	51
2	S	170/186 (91%)	164 (96%)	6 (4%)	31	51
2	T	170/186 (91%)	164 (96%)	6 (4%)	31	51
2	U	170/186 (91%)	164 (96%)	6 (4%)	31	51
2	V	170/186 (91%)	164 (96%)	6 (4%)	31	51
2	W	170/186 (91%)	164 (96%)	6 (4%)	31	51
2	X	170/186 (91%)	164 (96%)	6 (4%)	31	51
2	Y	170/186 (91%)	164 (96%)	6 (4%)	31	51
2	Z	170/186 (91%)	164 (96%)	6 (4%)	31	51
3	A0	102/113 (90%)	96 (94%)	6 (6%)	16	37

Continued on next page...

Continued from previous page...

Mol	Chain	Analysed	Rotameric	Outliers	Percentiles	
3	A6	110/113 (97%)	106 (96%)	4 (4%)	30	50
3	A7	101/113 (89%)	100 (99%)	1 (1%)	73	82
3	A8	103/113 (91%)	96 (93%)	7 (7%)	13	34
3	A9	104/113 (92%)	102 (98%)	2 (2%)	52	69
4	A1	68/79 (86%)	64 (94%)	4 (6%)	16	37
4	A2	70/79 (89%)	65 (93%)	5 (7%)	12	32
4	A3	70/79 (89%)	66 (94%)	4 (6%)	17	38
4	A4	70/79 (89%)	66 (94%)	4 (6%)	17	38
4	A5	69/79 (87%)	64 (93%)	5 (7%)	12	32
4	Az	45/79 (57%)	39 (87%)	6 (13%)	3	13
5	AA	190/193 (98%)	188 (99%)	2 (1%)	70	80
5	AB	191/193 (99%)	186 (97%)	5 (3%)	41	59
5	AC	192/193 (100%)	189 (98%)	3 (2%)	58	73
5	AD	192/193 (100%)	185 (96%)	7 (4%)	30	50
5	AE	191/193 (99%)	189 (99%)	2 (1%)	73	82
6	AO	141/467 (30%)	134 (95%)	7 (5%)	20	41
6	AP	141/467 (30%)	134 (95%)	7 (5%)	20	41
6	AQ	141/467 (30%)	134 (95%)	7 (5%)	20	41
6	AR	141/467 (30%)	134 (95%)	7 (5%)	20	41
6	AS	141/467 (30%)	134 (95%)	7 (5%)	20	41
6	AT	141/467 (30%)	134 (95%)	7 (5%)	20	41
6	AU	141/467 (30%)	134 (95%)	7 (5%)	20	41
6	AV	141/467 (30%)	134 (95%)	7 (5%)	20	41
6	AW	141/467 (30%)	134 (95%)	7 (5%)	20	41
6	AX	141/467 (30%)	134 (95%)	7 (5%)	20	41
6	AY	141/467 (30%)	134 (95%)	7 (5%)	20	41
6	AZ	141/467 (30%)	134 (95%)	7 (5%)	20	41
6	Aa	141/467 (30%)	134 (95%)	7 (5%)	20	41
6	Ac	141/467 (30%)	134 (95%)	7 (5%)	20	41
6	Ad	141/467 (30%)	134 (95%)	7 (5%)	20	41
6	Ae	141/467 (30%)	134 (95%)	7 (5%)	20	41

Continued on next page...

Continued from previous page...

Mol	Chain	Analysed	Rotameric	Outliers	Percentiles	
6	Af	141/467 (30%)	134 (95%)	7 (5%)	20	41
6	Ag	141/467 (30%)	134 (95%)	7 (5%)	20	41
6	Ah	141/467 (30%)	134 (95%)	7 (5%)	20	41
6	Ai	141/467 (30%)	134 (95%)	7 (5%)	20	41
6	Aj	141/467 (30%)	134 (95%)	7 (5%)	20	41
6	Ak	141/467 (30%)	134 (95%)	7 (5%)	20	41
6	Al	141/467 (30%)	134 (95%)	7 (5%)	20	41
6	Am	141/467 (30%)	134 (95%)	7 (5%)	20	41
6	An	141/467 (30%)	134 (95%)	7 (5%)	20	41
6	Ao	141/467 (30%)	134 (95%)	7 (5%)	20	41
6	Ap	141/467 (30%)	134 (95%)	7 (5%)	20	41
6	B6	26/467 (6%)	26 (100%)	0	100	100
6	BG	8/467 (2%)	6 (75%)	2 (25%)	0	3
6	BH	11/467 (2%)	10 (91%)	1 (9%)	7	24
6	BI	14/467 (3%)	12 (86%)	2 (14%)	2	12
6	BJ	11/467 (2%)	11 (100%)	0	100	100
6	BK	15/467 (3%)	15 (100%)	0	100	100
6	BL	11/467 (2%)	11 (100%)	0	100	100
6	BM	15/467 (3%)	15 (100%)	0	100	100
6	BN	11/467 (2%)	11 (100%)	0	100	100
6	BO	14/467 (3%)	13 (93%)	1 (7%)	12	32
6	BP	11/467 (2%)	11 (100%)	0	100	100
6	BQ	15/467 (3%)	14 (93%)	1 (7%)	13	34
6	BR	141/467 (30%)	134 (95%)	7 (5%)	20	41
6	BS	141/467 (30%)	134 (95%)	7 (5%)	20	41
6	BT	141/467 (30%)	134 (95%)	7 (5%)	20	41
6	BU	141/467 (30%)	134 (95%)	7 (5%)	20	41
6	BV	141/467 (30%)	134 (95%)	7 (5%)	20	41
6	BW	141/467 (30%)	134 (95%)	7 (5%)	20	41
6	BX	141/467 (30%)	134 (95%)	7 (5%)	20	41
6	Bb	26/467 (6%)	26 (100%)	0	100	100

Continued on next page...

Continued from previous page...

Mol	Chain	Analysed	Rotameric	Outliers	Percentiles	
6	Bh	26/467 (6%)	26 (100%)	0	100	100
6	Bn	26/467 (6%)	26 (100%)	0	100	100
6	Bt	26/467 (6%)	26 (100%)	0	100	100
6	Bz	26/467 (6%)	26 (100%)	0	100	100
6	C3	26/467 (6%)	26 (100%)	0	100	100
6	C7	26/467 (6%)	26 (100%)	0	100	100
6	CB	26/467 (6%)	26 (100%)	0	100	100
6	CH	26/467 (6%)	26 (100%)	0	100	100
6	CN	26/467 (6%)	26 (100%)	0	100	100
6	CT	26/467 (6%)	26 (100%)	0	100	100
6	CZ	26/467 (6%)	26 (100%)	0	100	100
6	Cf	26/467 (6%)	26 (100%)	0	100	100
6	Cl	26/467 (6%)	26 (100%)	0	100	100
6	Cr	26/467 (6%)	26 (100%)	0	100	100
6	Cx	26/467 (6%)	26 (100%)	0	100	100
6	D2	26/467 (6%)	26 (100%)	0	100	100
6	D8	26/467 (6%)	26 (100%)	0	100	100
6	DE	26/467 (6%)	26 (100%)	0	100	100
6	DK	26/467 (6%)	26 (100%)	0	100	100
6	DR	26/467 (6%)	26 (100%)	0	100	100
6	DX	26/467 (6%)	26 (100%)	0	100	100
6	Dd	26/467 (6%)	26 (100%)	0	100	100
6	Dj	26/467 (6%)	26 (100%)	0	100	100
6	Dp	26/467 (6%)	26 (100%)	0	100	100
6	Dv	26/467 (6%)	26 (100%)	0	100	100
6	EF	26/467 (6%)	26 (100%)	0	100	100
6	EL	26/467 (6%)	26 (100%)	0	100	100
6	ER	26/467 (6%)	26 (100%)	0	100	100
6	EX	26/467 (6%)	26 (100%)	0	100	100
6	Eb	26/467 (6%)	26 (100%)	0	100	100
6	Eh	26/467 (6%)	26 (100%)	0	100	100

Continued on next page...

Continued from previous page...

Mol	Chain	Analysed	Rotameric	Outliers	Percentiles	
6	En	26/467 (6%)	26 (100%)	0	100	100
6	UI	128/467 (27%)	123 (96%)	5 (4%)	27	48
6	UJ	128/467 (27%)	123 (96%)	5 (4%)	27	48
6	UK	128/467 (27%)	123 (96%)	5 (4%)	27	48
6	UL	128/467 (27%)	122 (95%)	6 (5%)	22	44
6	UM	128/467 (27%)	123 (96%)	5 (4%)	27	48
6	UN	128/467 (27%)	123 (96%)	5 (4%)	27	48
6	UO	128/467 (27%)	123 (96%)	5 (4%)	27	48
6	UP	128/467 (27%)	122 (95%)	6 (5%)	22	44
6	WA	95/467 (20%)	91 (96%)	4 (4%)	25	46
6	WB	93/467 (20%)	87 (94%)	6 (6%)	14	35
6	WC	91/467 (20%)	83 (91%)	8 (9%)	8	25
6	WD	92/467 (20%)	88 (96%)	4 (4%)	25	46
6	WE	94/467 (20%)	87 (93%)	7 (7%)	11	31
6	WF	93/467 (20%)	86 (92%)	7 (8%)	11	31
6	WG	94/467 (20%)	87 (93%)	7 (7%)	11	31
6	WH	79/467 (17%)	75 (95%)	4 (5%)	20	41
6	WI	79/467 (17%)	73 (92%)	6 (8%)	11	30
6	WJ	83/467 (18%)	79 (95%)	4 (5%)	21	43
6	WK	82/467 (18%)	77 (94%)	5 (6%)	15	37
6	WL	69/467 (15%)	66 (96%)	3 (4%)	25	46
6	WM	66/467 (14%)	65 (98%)	1 (2%)	60	75
6	WN	68/467 (15%)	66 (97%)	2 (3%)	37	56
6	WO	80/467 (17%)	76 (95%)	4 (5%)	20	41
6	WP	83/467 (18%)	77 (93%)	6 (7%)	12	32
6	WQ	93/467 (20%)	91 (98%)	2 (2%)	47	65
6	WR	93/467 (20%)	86 (92%)	7 (8%)	11	31
6	WS	93/467 (20%)	87 (94%)	6 (6%)	14	35
6	WT	93/467 (20%)	86 (92%)	7 (8%)	11	31
6	WU	94/467 (20%)	90 (96%)	4 (4%)	25	46
6	WV	92/467 (20%)	83 (90%)	9 (10%)	6	21

Continued on next page...

Continued from previous page...

Mol	Chain	Analysed	Rotameric	Outliers	Percentiles	
6	WW	93/467 (20%)	85 (91%)	8 (9%)	8	26
7	Ab	74/74 (100%)	68 (92%)	6 (8%)	9	28
7	Aq	74/74 (100%)	72 (97%)	2 (3%)	40	58
7	Ar	74/74 (100%)	74 (100%)	0	100	100
7	As	74/74 (100%)	74 (100%)	0	100	100
8	At	210/221 (95%)	205 (98%)	5 (2%)	44	62
9	Au	177/204 (87%)	171 (97%)	6 (3%)	32	51
9	Av	179/204 (88%)	172 (96%)	7 (4%)	27	48
9	Aw	178/204 (87%)	173 (97%)	5 (3%)	38	57
9	Ax	178/204 (87%)	171 (96%)	7 (4%)	27	48
9	Ay	179/204 (88%)	172 (96%)	7 (4%)	27	48
10	BA	104/105 (99%)	104 (100%)	0	100	100
10	BB	104/105 (99%)	101 (97%)	3 (3%)	37	56
10	BC	104/105 (99%)	102 (98%)	2 (2%)	52	69
10	BD	104/105 (99%)	100 (96%)	4 (4%)	28	49
10	BE	103/105 (98%)	99 (96%)	4 (4%)	27	48
10	BF	104/105 (99%)	98 (94%)	6 (6%)	17	38
11	ZF	321/323 (99%)	309 (96%)	12 (4%)	29	49
11	ZG	321/323 (99%)	305 (95%)	16 (5%)	20	41
11	ZH	321/323 (99%)	308 (96%)	13 (4%)	27	47
11	ZI	321/323 (99%)	315 (98%)	6 (2%)	52	69
11	ZJ	321/323 (99%)	312 (97%)	9 (3%)	38	57
11	ZK	321/323 (99%)	315 (98%)	6 (2%)	52	69
11	ZL	321/323 (99%)	311 (97%)	10 (3%)	35	54
11	ZM	321/323 (99%)	312 (97%)	9 (3%)	38	57
11	ZN	321/323 (99%)	311 (97%)	10 (3%)	35	54
11	ZO	321/323 (99%)	313 (98%)	8 (2%)	42	61
11	ZP	321/323 (99%)	306 (95%)	15 (5%)	22	44
11	ZQ	321/323 (99%)	312 (97%)	9 (3%)	38	57
11	ZR	321/323 (99%)	314 (98%)	7 (2%)	47	65
11	ZS	321/323 (99%)	315 (98%)	6 (2%)	52	69

Continued on next page...

Continued from previous page...

Mol	Chain	Analysed	Rotameric	Outliers	Percentiles	
11	ZT	321/323 (99%)	313 (98%)	8 (2%)	42	61
11	ZU	321/323 (99%)	317 (99%)	4 (1%)	67	78
11	ZV	321/323 (99%)	317 (99%)	4 (1%)	67	78
11	ZW	321/323 (99%)	307 (96%)	14 (4%)	24	45
11	ZX	321/323 (99%)	318 (99%)	3 (1%)	75	83
11	ZY	321/323 (99%)	314 (98%)	7 (2%)	47	65
11	ZZ	321/323 (99%)	316 (98%)	5 (2%)	58	73
11	Za	321/323 (99%)	315 (98%)	6 (2%)	52	69
11	Zb	321/323 (99%)	314 (98%)	7 (2%)	47	65
11	Zc	321/323 (99%)	310 (97%)	11 (3%)	32	51
11	Zd	321/323 (99%)	315 (98%)	6 (2%)	52	69
11	Ze	321/323 (99%)	314 (98%)	7 (2%)	47	65
11	Zf	321/323 (99%)	314 (98%)	7 (2%)	47	65
11	Zg	321/323 (99%)	314 (98%)	7 (2%)	47	65
11	Zh	321/323 (99%)	314 (98%)	7 (2%)	47	65
12	a	248/294 (84%)	243 (98%)	5 (2%)	50	68
12	b	248/294 (84%)	243 (98%)	5 (2%)	50	68
12	c	248/294 (84%)	243 (98%)	5 (2%)	50	68
12	d	248/294 (84%)	243 (98%)	5 (2%)	50	68
12	e	248/294 (84%)	243 (98%)	5 (2%)	50	68
12	f	248/294 (84%)	243 (98%)	5 (2%)	50	68
12	g	248/294 (84%)	243 (98%)	5 (2%)	50	68
12	h	248/294 (84%)	243 (98%)	5 (2%)	50	68
12	i	248/294 (84%)	243 (98%)	5 (2%)	50	68
12	j	248/294 (84%)	243 (98%)	5 (2%)	50	68
12	k	248/294 (84%)	243 (98%)	5 (2%)	50	68
12	l	248/294 (84%)	243 (98%)	5 (2%)	50	68
12	m	248/294 (84%)	243 (98%)	5 (2%)	50	68
12	n	248/294 (84%)	243 (98%)	5 (2%)	50	68
12	o	248/294 (84%)	243 (98%)	5 (2%)	50	68
12	p	248/294 (84%)	243 (98%)	5 (2%)	50	68

Continued on next page...

Continued from previous page...

Mol	Chain	Analysed	Rotameric	Outliers	Percentiles	
12	q	248/294 (84%)	243 (98%)	5 (2%)	50	68
12	r	248/294 (84%)	243 (98%)	5 (2%)	50	68
12	s	248/294 (84%)	243 (98%)	5 (2%)	50	68
12	t	248/294 (84%)	243 (98%)	5 (2%)	50	68
12	u	248/294 (84%)	243 (98%)	5 (2%)	50	68
12	v	248/294 (84%)	243 (98%)	5 (2%)	50	68
12	w	248/294 (84%)	243 (98%)	5 (2%)	50	68
12	x	248/294 (84%)	243 (98%)	5 (2%)	50	68
12	y	248/294 (84%)	243 (98%)	5 (2%)	50	68
12	z	248/294 (84%)	243 (98%)	5 (2%)	50	68
13	B0	76/113 (67%)	73 (96%)	3 (4%)	27	48
13	B2	76/113 (67%)	73 (96%)	3 (4%)	27	48
13	B3	76/113 (67%)	73 (96%)	3 (4%)	27	48
13	B4	76/113 (67%)	73 (96%)	3 (4%)	27	48
13	B8	76/113 (67%)	73 (96%)	3 (4%)	27	48
13	B9	76/113 (67%)	73 (96%)	3 (4%)	27	48
13	BY	76/113 (67%)	73 (96%)	3 (4%)	27	48
13	BZ	76/113 (67%)	73 (96%)	3 (4%)	27	48
13	Bd	76/113 (67%)	73 (96%)	3 (4%)	27	48
13	Be	76/113 (67%)	73 (96%)	3 (4%)	27	48
13	Bf	76/113 (67%)	73 (96%)	3 (4%)	27	48
13	Bj	76/113 (67%)	73 (96%)	3 (4%)	27	48
13	Bk	76/113 (67%)	73 (96%)	3 (4%)	27	48
13	Bl	76/113 (67%)	73 (96%)	3 (4%)	27	48
13	Bp	76/113 (67%)	73 (96%)	3 (4%)	27	48
13	Bq	76/113 (67%)	73 (96%)	3 (4%)	27	48
13	Br	76/113 (67%)	73 (96%)	3 (4%)	27	48
13	Bv	76/113 (67%)	73 (96%)	3 (4%)	27	48
13	Bw	76/113 (67%)	73 (96%)	3 (4%)	27	48
13	Bx	76/113 (67%)	73 (96%)	3 (4%)	27	48
13	C0	76/113 (67%)	73 (96%)	3 (4%)	27	48

Continued on next page...

Continued from previous page...

Mol	Chain	Analysed	Rotameric	Outliers	Percentiles	
13	C1	76/113 (67%)	73 (96%)	3 (4%)	27	48
13	C2	76/113 (67%)	73 (96%)	3 (4%)	27	48
13	C4	76/113 (67%)	73 (96%)	3 (4%)	27	48
13	C5	76/113 (67%)	73 (96%)	3 (4%)	27	48
13	C9	76/113 (67%)	73 (96%)	3 (4%)	27	48
13	CD	76/113 (67%)	73 (96%)	3 (4%)	27	48
13	CE	76/113 (67%)	73 (96%)	3 (4%)	27	48
13	CF	76/113 (67%)	73 (96%)	3 (4%)	27	48
13	CJ	76/113 (67%)	73 (96%)	3 (4%)	27	48
13	CK	76/113 (67%)	73 (96%)	3 (4%)	27	48
13	CL	76/113 (67%)	73 (96%)	3 (4%)	27	48
13	CP	76/113 (67%)	73 (96%)	3 (4%)	27	48
13	CQ	76/113 (67%)	73 (96%)	3 (4%)	27	48
13	CR	76/113 (67%)	73 (96%)	3 (4%)	27	48
13	CV	76/113 (67%)	73 (96%)	3 (4%)	27	48
13	CW	76/113 (67%)	73 (96%)	3 (4%)	27	48
13	CX	76/113 (67%)	73 (96%)	3 (4%)	27	48
13	Cb	76/113 (67%)	73 (96%)	3 (4%)	27	48
13	Cc	76/113 (67%)	73 (96%)	3 (4%)	27	48
13	Cd	76/113 (67%)	73 (96%)	3 (4%)	27	48
13	Ch	76/113 (67%)	73 (96%)	3 (4%)	27	48
13	Ci	76/113 (67%)	73 (96%)	3 (4%)	27	48
13	Cj	76/113 (67%)	73 (96%)	3 (4%)	27	48
13	Cn	76/113 (67%)	73 (96%)	3 (4%)	27	48
13	Co	76/113 (67%)	73 (96%)	3 (4%)	27	48
13	Cp	76/113 (67%)	73 (96%)	3 (4%)	27	48
13	Ct	76/113 (67%)	73 (96%)	3 (4%)	27	48
13	Cu	76/113 (67%)	73 (96%)	3 (4%)	27	48
13	Cv	76/113 (67%)	73 (96%)	3 (4%)	27	48
13	Cz	76/113 (67%)	73 (96%)	3 (4%)	27	48
13	D0	76/113 (67%)	73 (96%)	3 (4%)	27	48

Continued on next page...

Continued from previous page...

Mol	Chain	Analysed	Rotameric	Outliers	Percentiles	
13	D4	76/113 (67%)	73 (96%)	3 (4%)	27	48
13	D5	76/113 (67%)	73 (96%)	3 (4%)	27	48
13	D6	76/113 (67%)	73 (96%)	3 (4%)	27	48
13	DA	76/113 (67%)	73 (96%)	3 (4%)	27	48
13	DC	76/113 (67%)	73 (96%)	3 (4%)	27	48
13	DG	76/113 (67%)	73 (96%)	3 (4%)	27	48
13	DH	76/113 (67%)	73 (96%)	3 (4%)	27	48
13	DI	76/113 (67%)	73 (96%)	3 (4%)	27	48
13	DN	76/113 (67%)	73 (96%)	3 (4%)	27	48
13	DO	76/113 (67%)	73 (96%)	3 (4%)	27	48
13	DP	76/113 (67%)	73 (96%)	3 (4%)	27	48
13	DT	76/113 (67%)	73 (96%)	3 (4%)	27	48
13	DU	76/113 (67%)	73 (96%)	3 (4%)	27	48
13	DV	76/113 (67%)	73 (96%)	3 (4%)	27	48
13	DZ	76/113 (67%)	73 (96%)	3 (4%)	27	48
13	Da	76/113 (67%)	73 (96%)	3 (4%)	27	48
13	Db	76/113 (67%)	73 (96%)	3 (4%)	27	48
13	Df	76/113 (67%)	73 (96%)	3 (4%)	27	48
13	Dg	76/113 (67%)	73 (96%)	3 (4%)	27	48
13	Dh	76/113 (67%)	73 (96%)	3 (4%)	27	48
13	DI	76/113 (67%)	73 (96%)	3 (4%)	27	48
13	Dm	76/113 (67%)	73 (96%)	3 (4%)	27	48
13	Dn	76/113 (67%)	73 (96%)	3 (4%)	27	48
13	Dr	76/113 (67%)	73 (96%)	3 (4%)	27	48
13	Ds	76/113 (67%)	73 (96%)	3 (4%)	27	48
13	Dt	76/113 (67%)	73 (96%)	3 (4%)	27	48
13	Dx	76/113 (67%)	73 (96%)	3 (4%)	27	48
13	Dy	76/113 (67%)	73 (96%)	3 (4%)	27	48
13	Dz	76/113 (67%)	73 (96%)	3 (4%)	27	48
13	EA	76/113 (67%)	73 (96%)	3 (4%)	27	48
13	EB	76/113 (67%)	73 (96%)	3 (4%)	27	48

Continued on next page...

Continued from previous page...

Mol	Chain	Analysed	Rotameric	Outliers	Percentiles	
13	EC	76/113 (67%)	73 (96%)	3 (4%)	27	48
13	ED	76/113 (67%)	73 (96%)	3 (4%)	27	48
13	EH	76/113 (67%)	73 (96%)	3 (4%)	27	48
13	EI	76/113 (67%)	73 (96%)	3 (4%)	27	48
13	EJ	76/113 (67%)	73 (96%)	3 (4%)	27	48
13	EN	76/113 (67%)	73 (96%)	3 (4%)	27	48
13	EO	76/113 (67%)	73 (96%)	3 (4%)	27	48
13	EP	76/113 (67%)	73 (96%)	3 (4%)	27	48
13	ET	76/113 (67%)	73 (96%)	3 (4%)	27	48
13	EU	76/113 (67%)	73 (96%)	3 (4%)	27	48
13	EV	76/113 (67%)	73 (96%)	3 (4%)	27	48
13	EZ	76/113 (67%)	73 (96%)	3 (4%)	27	48
13	Ed	76/113 (67%)	73 (96%)	3 (4%)	27	48
13	Ee	76/113 (67%)	73 (96%)	3 (4%)	27	48
13	Ef	76/113 (67%)	73 (96%)	3 (4%)	27	48
13	Ej	76/113 (67%)	73 (96%)	3 (4%)	27	48
13	Ek	76/113 (67%)	73 (96%)	3 (4%)	27	48
13	El	76/113 (67%)	73 (96%)	3 (4%)	27	48
13	Ep	76/113 (67%)	73 (96%)	3 (4%)	27	48
14	B5	268/282 (95%)	265 (99%)	3 (1%)	70	80
14	Ba	268/282 (95%)	265 (99%)	3 (1%)	70	80
14	Bg	268/282 (95%)	265 (99%)	3 (1%)	70	80
14	Bm	268/282 (95%)	265 (99%)	3 (1%)	70	80
14	Bs	268/282 (95%)	265 (99%)	3 (1%)	70	80
14	By	268/282 (95%)	265 (99%)	3 (1%)	70	80
14	C6	268/282 (95%)	265 (99%)	3 (1%)	70	80
14	CA	268/282 (95%)	265 (99%)	3 (1%)	70	80
14	CG	268/282 (95%)	265 (99%)	3 (1%)	70	80
14	CM	268/282 (95%)	265 (99%)	3 (1%)	70	80
14	CS	268/282 (95%)	265 (99%)	3 (1%)	70	80
14	CY	268/282 (95%)	265 (99%)	3 (1%)	70	80

Continued on next page...

Continued from previous page...

Mol	Chain	Analysed	Rotameric	Outliers	Percentiles	
14	Ce	268/282 (95%)	265 (99%)	3 (1%)	70	80
14	Ck	268/282 (95%)	265 (99%)	3 (1%)	70	80
14	Cq	268/282 (95%)	265 (99%)	3 (1%)	70	80
14	Cw	268/282 (95%)	265 (99%)	3 (1%)	70	80
14	D1	268/282 (95%)	265 (99%)	3 (1%)	70	80
14	D7	268/282 (95%)	265 (99%)	3 (1%)	70	80
14	DB	268/282 (95%)	265 (99%)	3 (1%)	70	80
14	DD	268/282 (95%)	265 (99%)	3 (1%)	70	80
14	DJ	268/282 (95%)	265 (99%)	3 (1%)	70	80
14	DQ	268/282 (95%)	265 (99%)	3 (1%)	70	80
14	DW	268/282 (95%)	265 (99%)	3 (1%)	70	80
14	Dc	268/282 (95%)	265 (99%)	3 (1%)	70	80
14	Di	268/282 (95%)	265 (99%)	3 (1%)	70	80
14	Do	268/282 (95%)	265 (99%)	3 (1%)	70	80
14	Du	268/282 (95%)	265 (99%)	3 (1%)	70	80
14	EE	268/282 (95%)	265 (99%)	3 (1%)	70	80
14	EK	268/282 (95%)	265 (99%)	3 (1%)	70	80
14	EQ	268/282 (95%)	265 (99%)	3 (1%)	70	80
14	EW	268/282 (95%)	265 (99%)	3 (1%)	70	80
14	Ea	268/282 (95%)	265 (99%)	3 (1%)	70	80
14	Eg	268/282 (95%)	265 (99%)	3 (1%)	70	80
14	Em	268/282 (95%)	265 (99%)	3 (1%)	70	80
15	B1	262/301 (87%)	250 (95%)	12 (5%)	23	44
15	B7	262/301 (87%)	250 (95%)	12 (5%)	23	44
15	Bc	262/301 (87%)	250 (95%)	12 (5%)	23	44
15	Bi	262/301 (87%)	250 (95%)	12 (5%)	23	44
15	Bo	262/301 (87%)	250 (95%)	12 (5%)	23	44
15	Bu	262/301 (87%)	250 (95%)	12 (5%)	23	44
15	C8	262/301 (87%)	250 (95%)	12 (5%)	23	44
15	CC	262/301 (87%)	250 (95%)	12 (5%)	23	44
15	CI	262/301 (87%)	250 (95%)	12 (5%)	23	44

Continued on next page...

Continued from previous page...

Mol	Chain	Analysed	Rotameric	Outliers	Percentiles	
15	CO	262/301 (87%)	250 (95%)	12 (5%)	23	44
15	CU	262/301 (87%)	250 (95%)	12 (5%)	23	44
15	Ca	262/301 (87%)	250 (95%)	12 (5%)	23	44
15	Cg	262/301 (87%)	250 (95%)	12 (5%)	23	44
15	Cm	262/301 (87%)	250 (95%)	12 (5%)	23	44
15	Cs	262/301 (87%)	250 (95%)	12 (5%)	23	44
15	Cy	262/301 (87%)	250 (95%)	12 (5%)	23	44
15	D3	262/301 (87%)	250 (95%)	12 (5%)	23	44
15	D9	262/301 (87%)	250 (95%)	12 (5%)	23	44
15	DF	262/301 (87%)	250 (95%)	12 (5%)	23	44
15	DL	262/301 (87%)	250 (95%)	12 (5%)	23	44
15	DM	262/301 (87%)	250 (95%)	12 (5%)	23	44
15	DS	262/301 (87%)	250 (95%)	12 (5%)	23	44
15	DY	262/301 (87%)	250 (95%)	12 (5%)	23	44
15	De	262/301 (87%)	250 (95%)	12 (5%)	23	44
15	Dk	262/301 (87%)	250 (95%)	12 (5%)	23	44
15	Dq	262/301 (87%)	250 (95%)	12 (5%)	23	44
15	Dw	262/301 (87%)	250 (95%)	12 (5%)	23	44
15	EG	262/301 (87%)	250 (95%)	12 (5%)	23	44
15	EM	262/301 (87%)	250 (95%)	12 (5%)	23	44
15	ES	262/301 (87%)	250 (95%)	12 (5%)	23	44
15	EY	262/301 (87%)	250 (95%)	12 (5%)	23	44
15	Ec	262/301 (87%)	250 (95%)	12 (5%)	23	44
15	Ei	262/301 (87%)	250 (95%)	12 (5%)	23	44
15	Eo	262/301 (87%)	250 (95%)	12 (5%)	23	44
All	All	63740/113896 (56%)	61719 (97%)	2021 (3%)	36	53

5 of 2021 residues with a non-rotameric sidechain are listed below:

Mol	Chain	Res	Type
11	ZN	396	LEU
15	CI	46	VAL
12	o	110	MET

Continued on next page...

Continued from previous page...

Mol	Chain	Res	Type
15	CC	162	LEU
15	Cm	45	ARG

Sometimes sidechains can be flipped to improve hydrogen bonding and reduce clashes. 5 of 1300 such sidechains are listed below:

Mol	Chain	Res	Type
12	s	159	GLN
14	EW	180	ASN
12	w	140	ASN
12	s	140	ASN
14	Dc	49	ASN

5.3.3 RNA [i](#)

There are no RNA molecules in this entry.

5.4 Non-standard residues in protein, DNA, RNA chains [i](#)

There are no non-standard protein/DNA/RNA residues in this entry.

5.5 Carbohydrates [i](#)

There are no oligosaccharides in this entry.

5.6 Ligand geometry [i](#)

There are no ligands in this entry.

5.7 Other polymers [i](#)

There are no such residues in this entry.

5.8 Polymer linkage issues [i](#)

There are no chain breaks in this entry.

6 Map visualisation [i](#)

This section contains visualisations of the EMDB entry EMD-37679. These allow visual inspection of the internal detail of the map and identification of artifacts.

Images derived from a raw map, generated by summing the deposited half-maps, are presented below the corresponding image components of the primary map to allow further visual inspection and comparison with those of the primary map.

6.1 Orthogonal projections [i](#)

6.1.1 Primary map

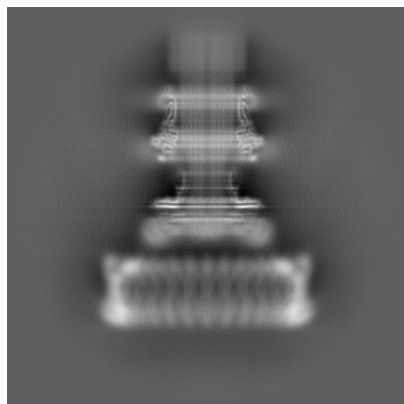

X

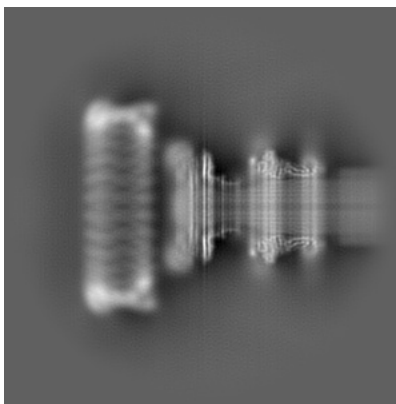

Y

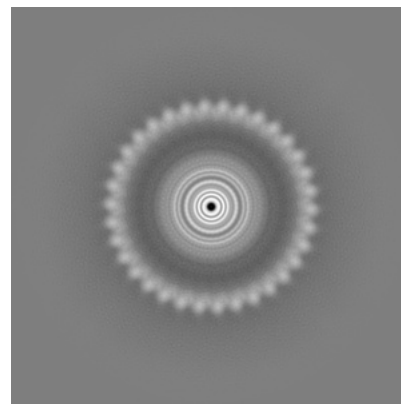

Z

6.1.2 Raw map

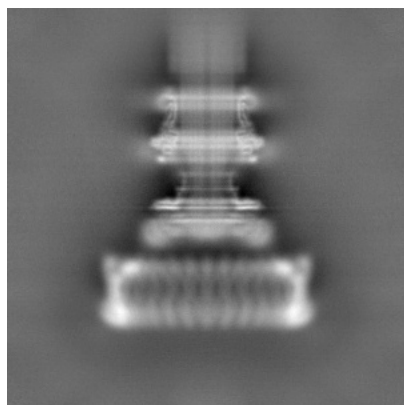

X

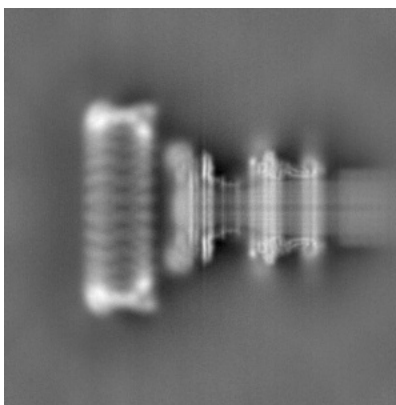

Y

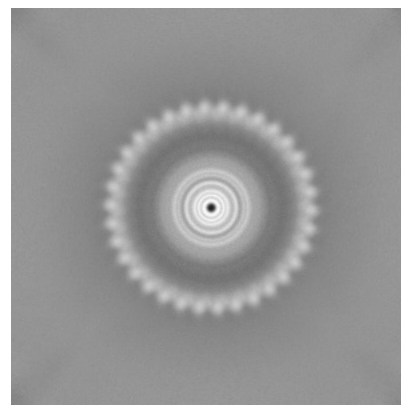

Z

The images above show the map projected in three orthogonal directions.

6.2 Central slices [i](#)

6.2.1 Primary map

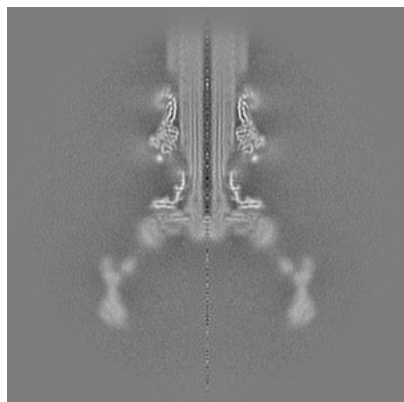

X Index: 400

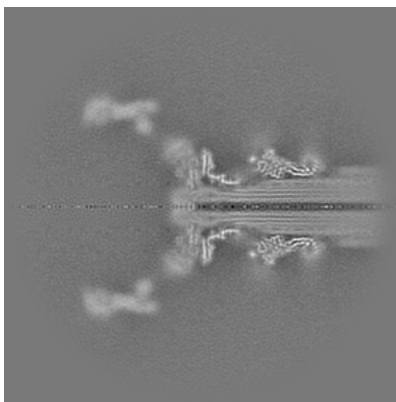

Y Index: 400

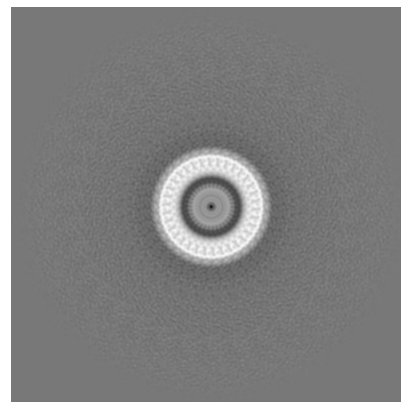

Z Index: 400

6.2.2 Raw map

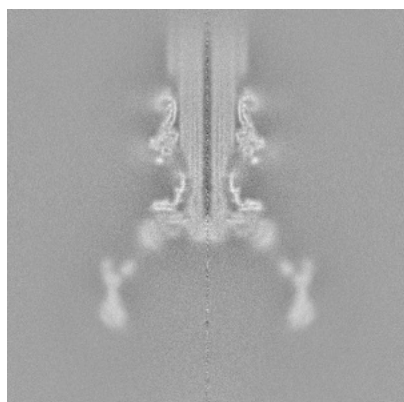

X Index: 400

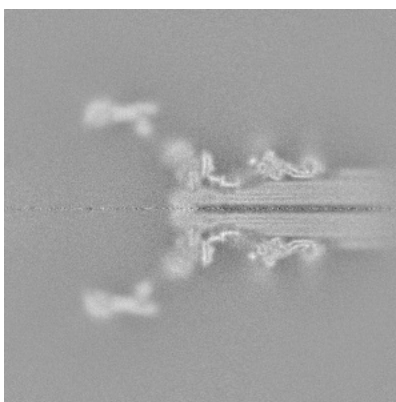

Y Index: 400

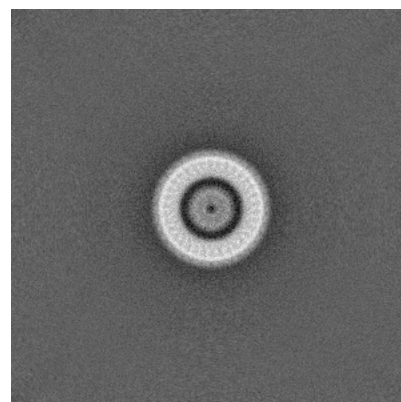

Z Index: 400

The images above show central slices of the map in three orthogonal directions.

6.3 Largest variance slices [i](#)

6.3.1 Primary map

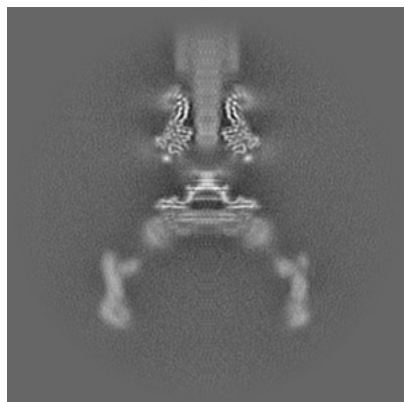

X Index: 449

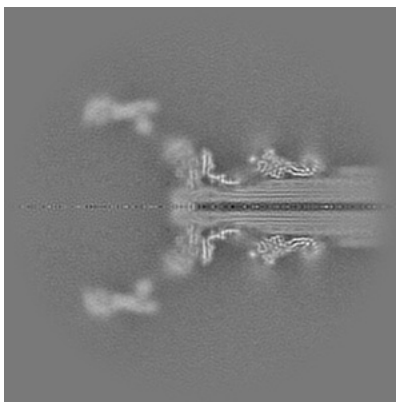

Y Index: 400

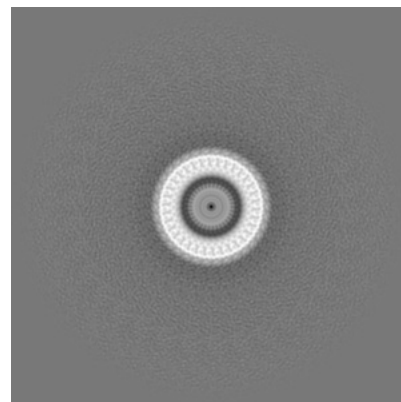

Z Index: 400

6.3.2 Raw map

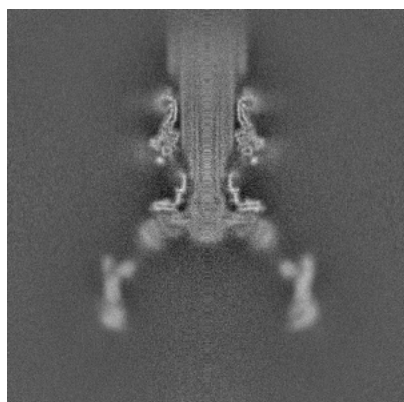

X Index: 386

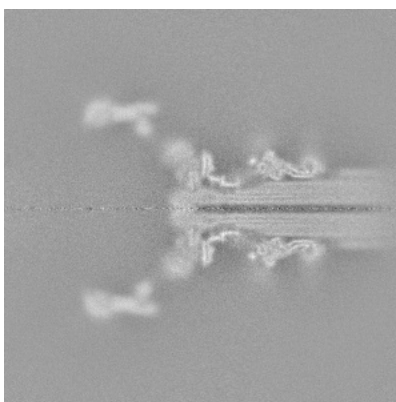

Y Index: 400

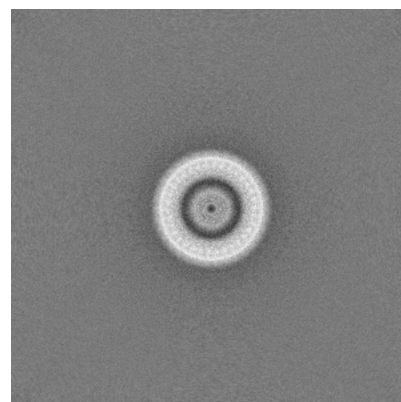

Z Index: 401

The images above show the largest variance slices of the map in three orthogonal directions.

6.4 Orthogonal standard-deviation projections (False-color) [i](#)

6.4.1 Primary map

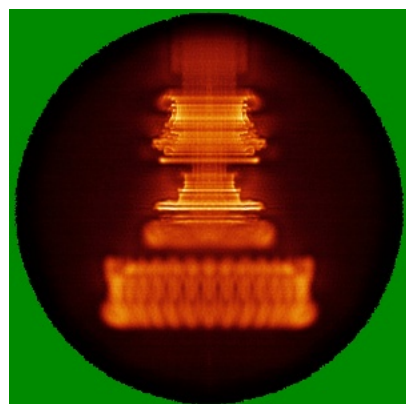

X

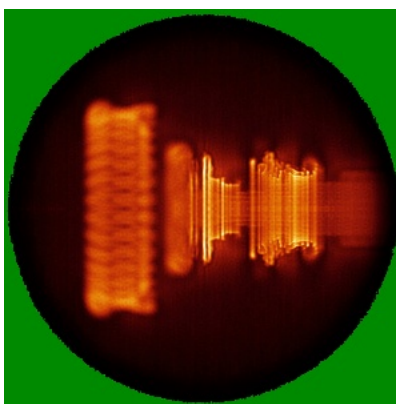

Y

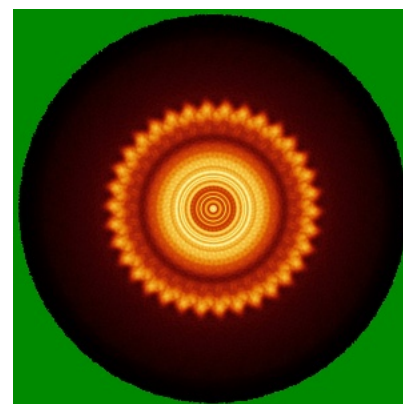

Z

6.4.2 Raw map

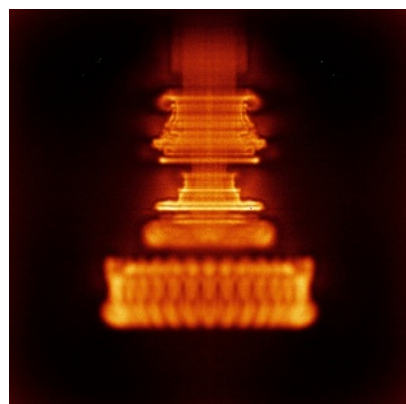

X

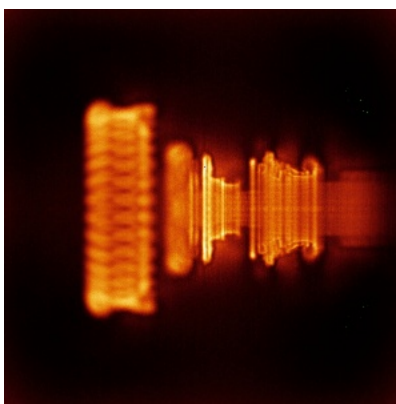

Y

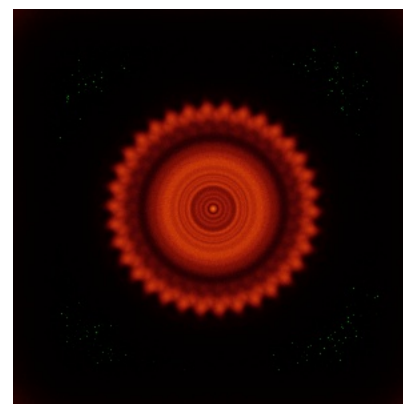

Z

The images above show the map standard deviation projections with false color in three orthogonal directions. Minimum values are shown in green, max in blue, and dark to light orange shades represent small to large values respectively.

6.5 Orthogonal surface views [i](#)

6.5.1 Primary map

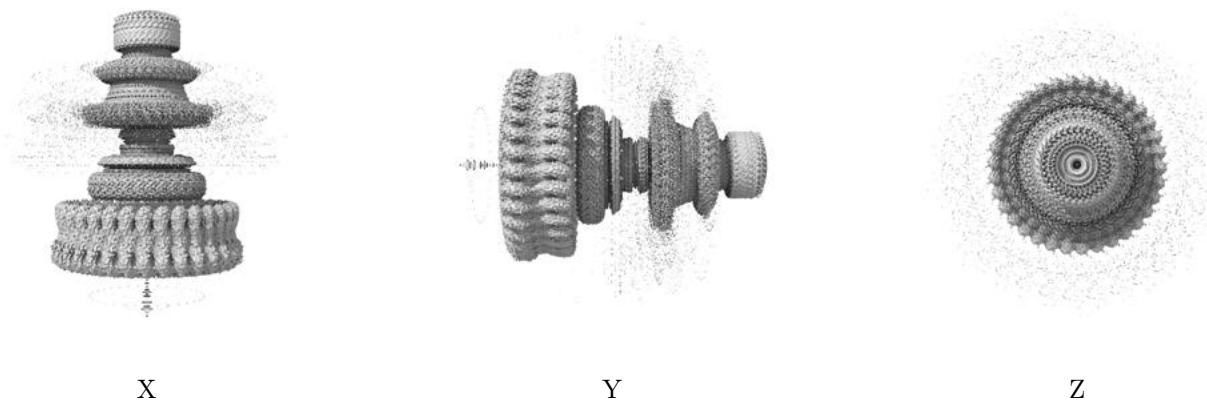

The images above show the 3D surface view of the map at the recommended contour level 0.05. These images, in conjunction with the slice images, may facilitate assessment of whether an appropriate contour level has been provided.

6.5.2 Raw map

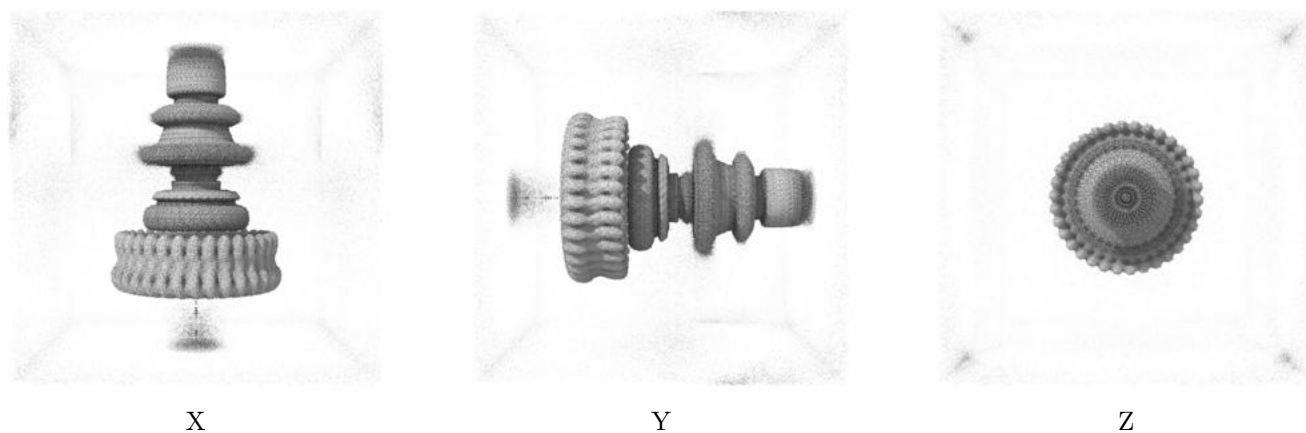

These images show the 3D surface of the raw map. The raw map's contour level was selected so that its surface encloses the same volume as the primary map does at its recommended contour level.

6.6 Mask visualisation [i](#)

This section was not generated. No masks/segmentation were deposited.

7 Map analysis [i](#)

This section contains the results of statistical analysis of the map.

7.1 Map-value distribution [i](#)

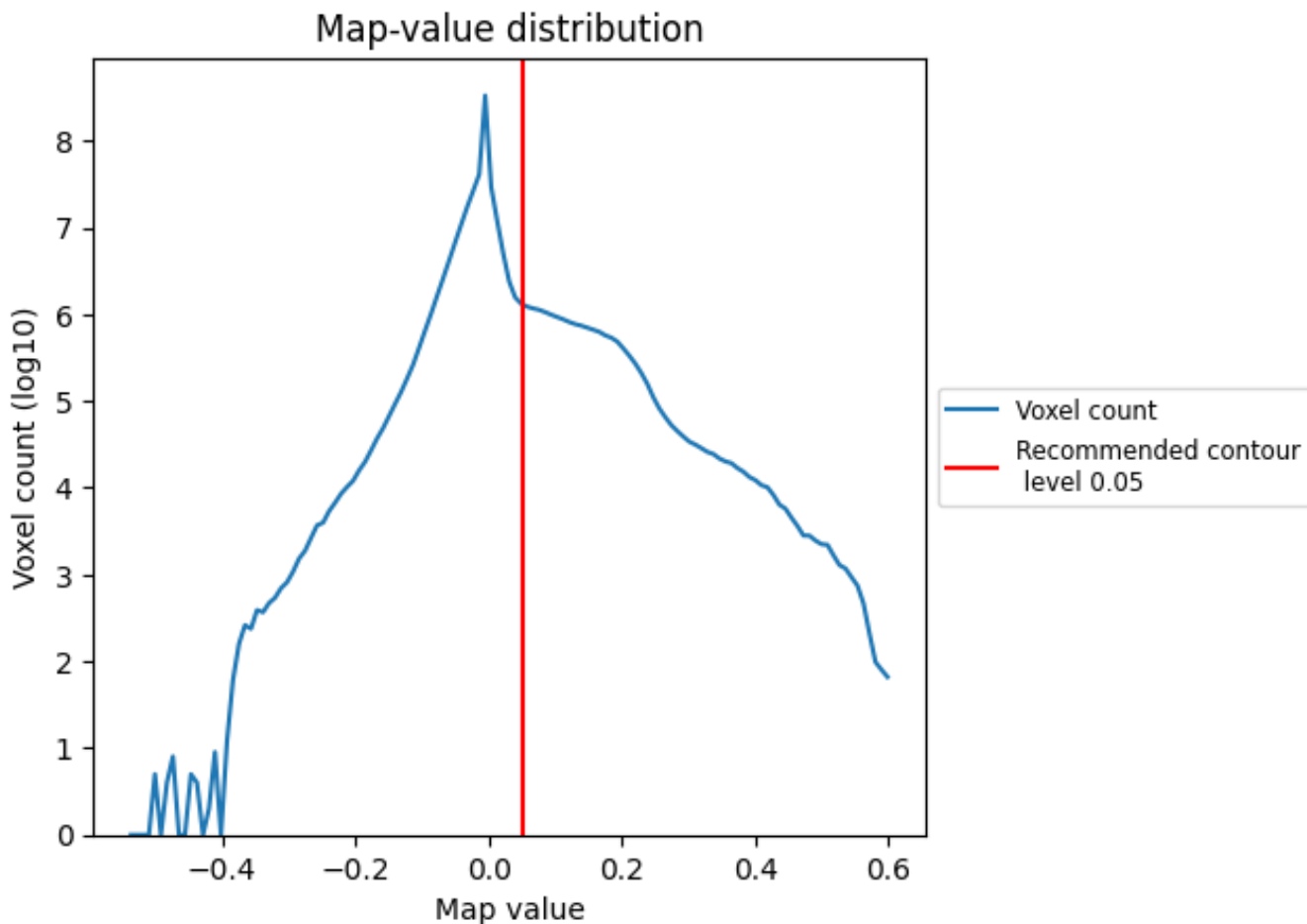

The map-value distribution is plotted in 128 intervals along the x-axis. The y-axis is logarithmic. A spike in this graph at zero usually indicates that the volume has been masked.

7.2 Volume estimate [i](#)

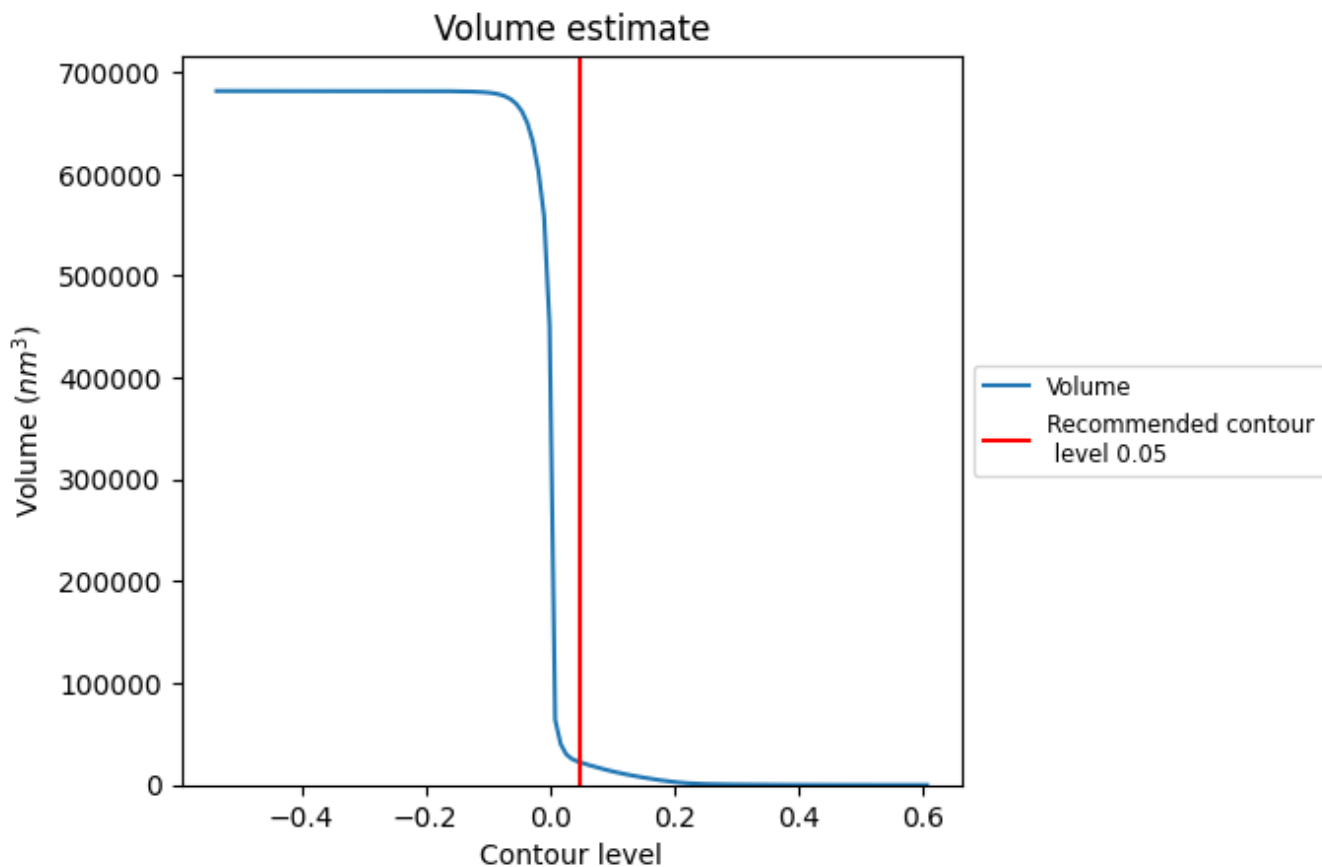

The volume at the recommended contour level is 22073 nm³; this corresponds to an approximate mass of 19939 kDa.

The volume estimate graph shows how the enclosed volume varies with the contour level. The recommended contour level is shown as a vertical line and the intersection between the line and the curve gives the volume of the enclosed surface at the given level.

7.3 Rotationally averaged power spectrum [i](#)

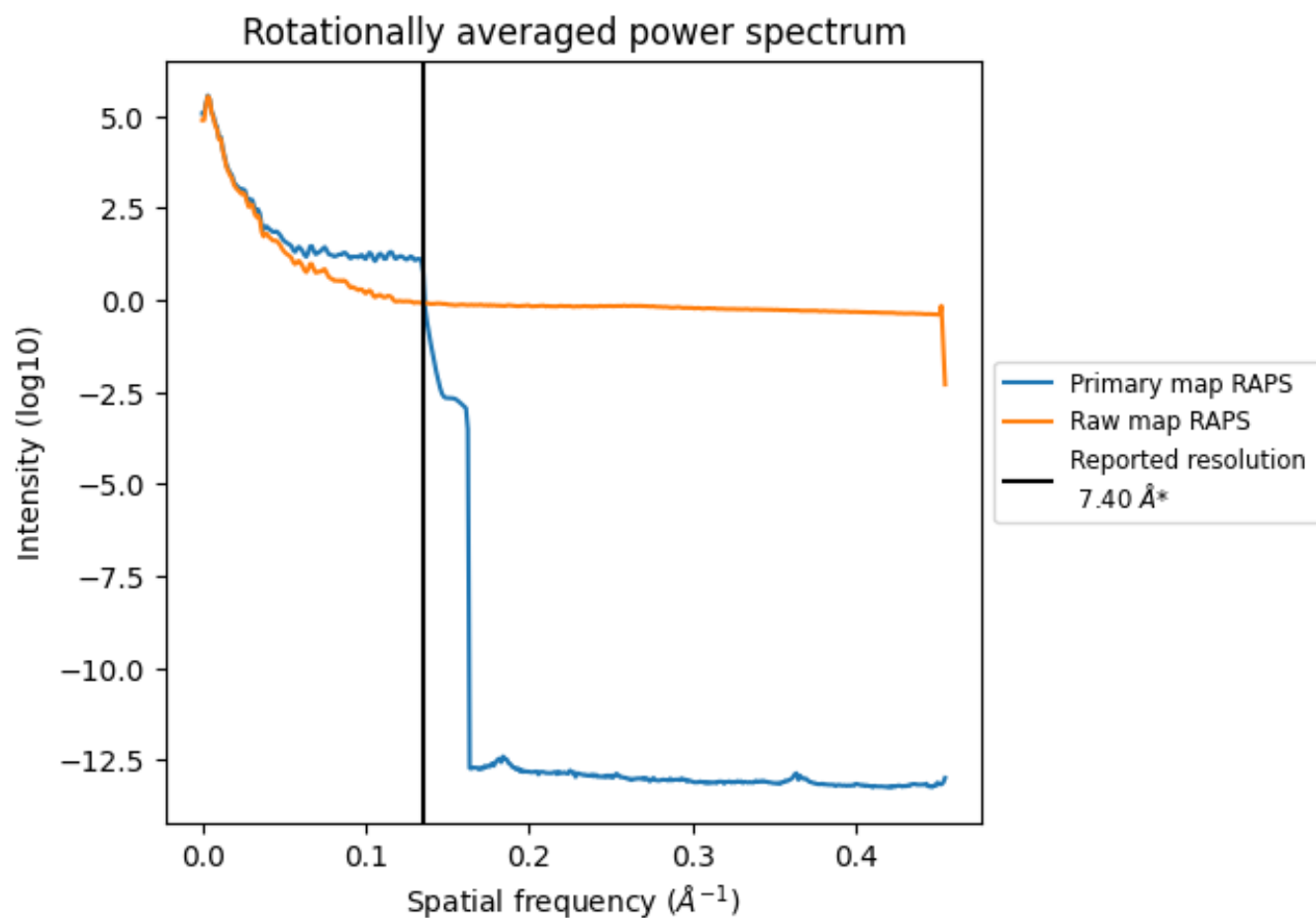

*Reported resolution corresponds to spatial frequency of 0.135 Å⁻¹

8 Fourier-Shell correlation [i](#)

Fourier-Shell Correlation (FSC) is the most commonly used method to estimate the resolution of single-particle and subtomogram-averaged maps. The shape of the curve depends on the imposed symmetry, mask and whether or not the two 3D reconstructions used were processed from a common reference. The reported resolution is shown as a black line. A curve is displayed for the half-bit criterion in addition to lines showing the 0.143 gold standard cut-off and 0.5 cut-off.

8.1 FSC [i](#)

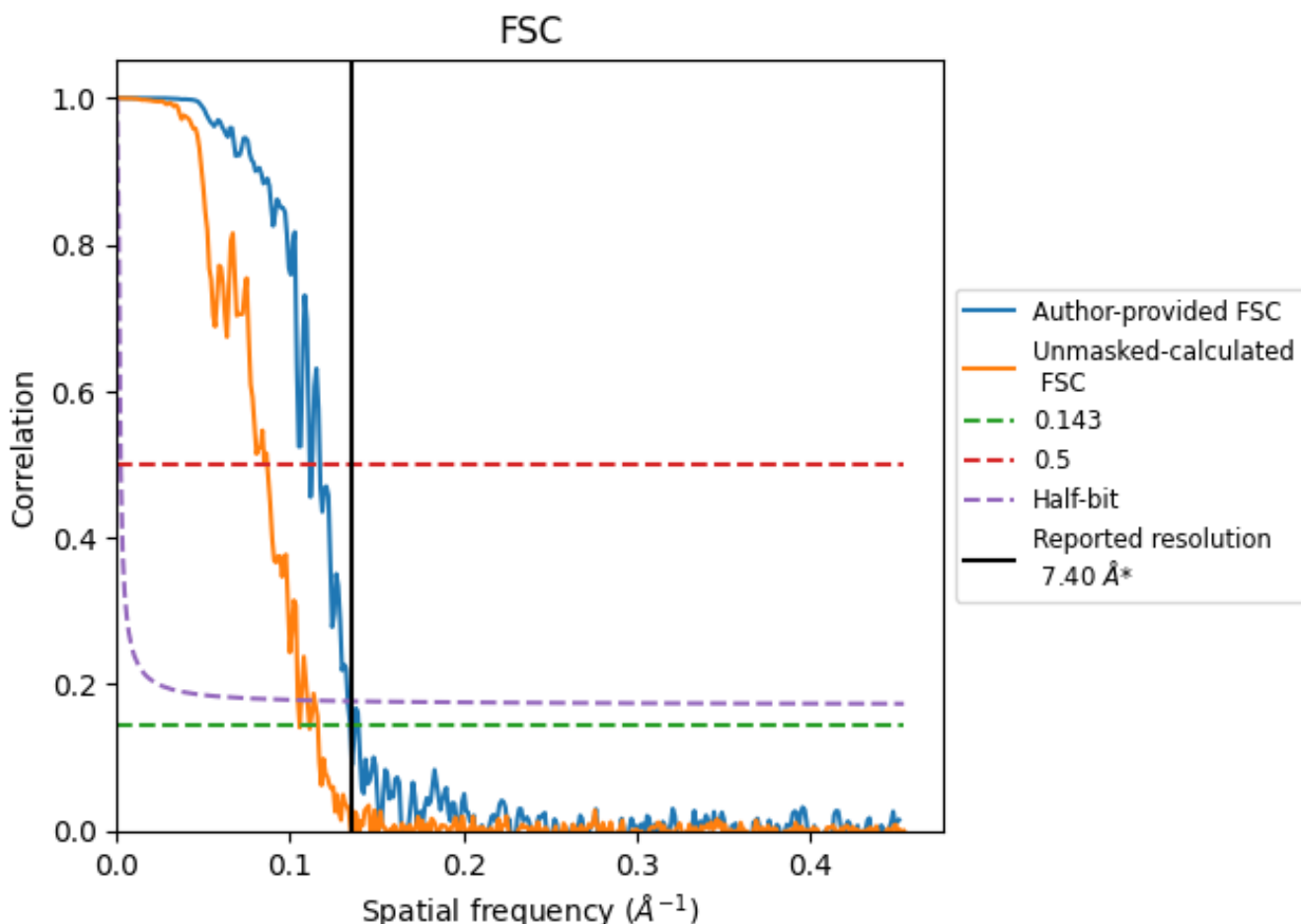

*Reported resolution corresponds to spatial frequency of 0.135 Å⁻¹

8.2 Resolution estimates [i](#)

Resolution estimate (Å)	Estimation criterion (FSC cut-off)		
	0.143	0.5	Half-bit
Reported by author	7.40	-	-
Author-provided FSC curve	7.42	8.97	7.50
Unmasked-calculated*	9.47	11.52	9.55

*Resolution estimate based on FSC curve calculated by comparison of deposited half-maps. The value from deposited half-maps intersecting FSC 0.143 CUT-OFF 9.47 differs from the reported value 7.4 by more than 10 %

9 Map-model fit [i](#)

This section contains information regarding the fit between EMDB map EMD-37679 and PDB model 8WO5. Per-residue inclusion information can be found in section [3](#) on page [42](#).

9.1 Map-model overlay [i](#)

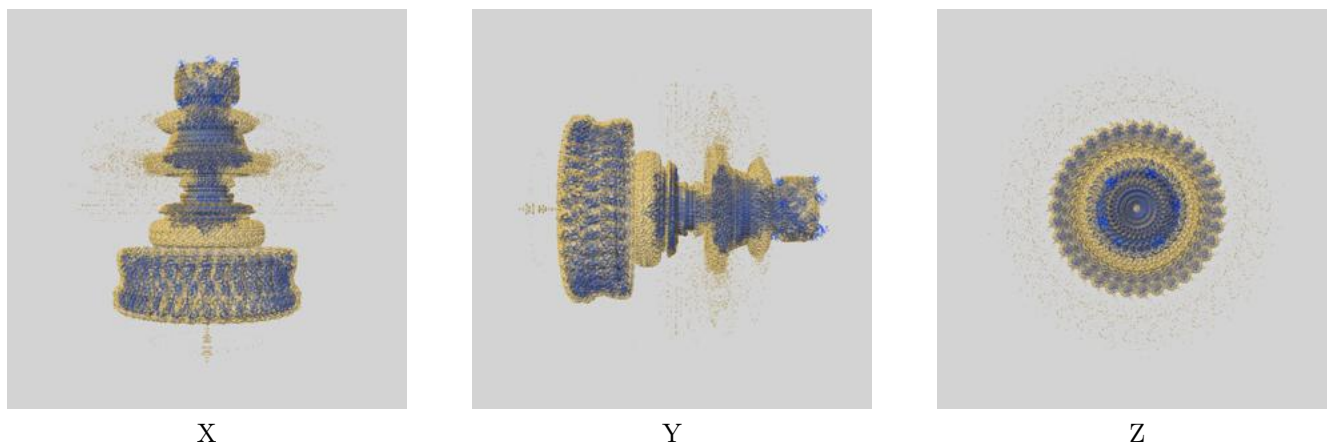

The images above show the 3D surface view of the map at the recommended contour level 0.05 at 50% transparency in yellow overlaid with a ribbon representation of the model coloured in blue. These images allow for the visual assessment of the quality of fit between the atomic model and the map.

9.2 Q-score mapped to coordinate model [i](#)

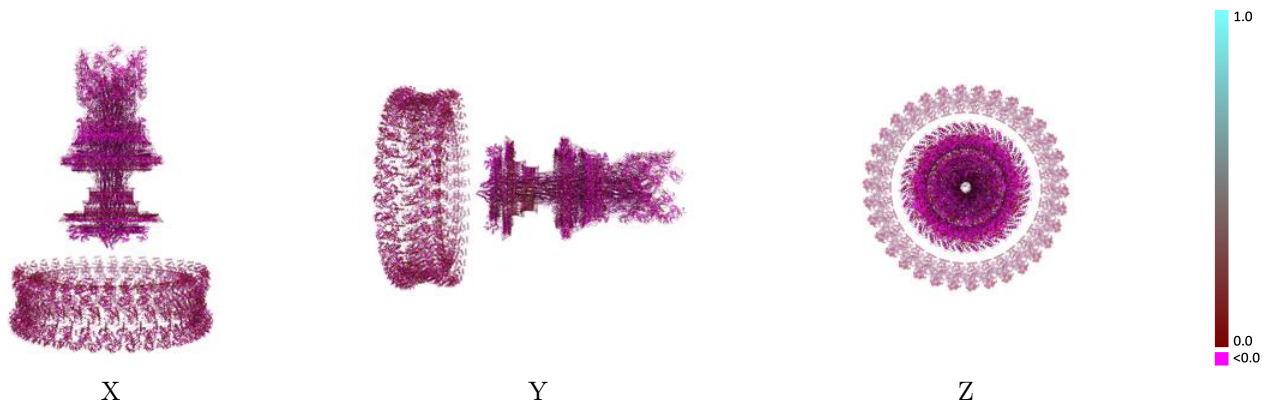

The images above show the model with each residue coloured according its Q-score. This shows their resolvability in the map with higher Q-score values reflecting better resolvability. Please note: Q-score is calculating the resolvability of atoms, and thus high values are only expected at resolutions at which atoms can be resolved. Low Q-score values may therefore be expected for many entries.

9.3 Atom inclusion mapped to coordinate model [i](#)

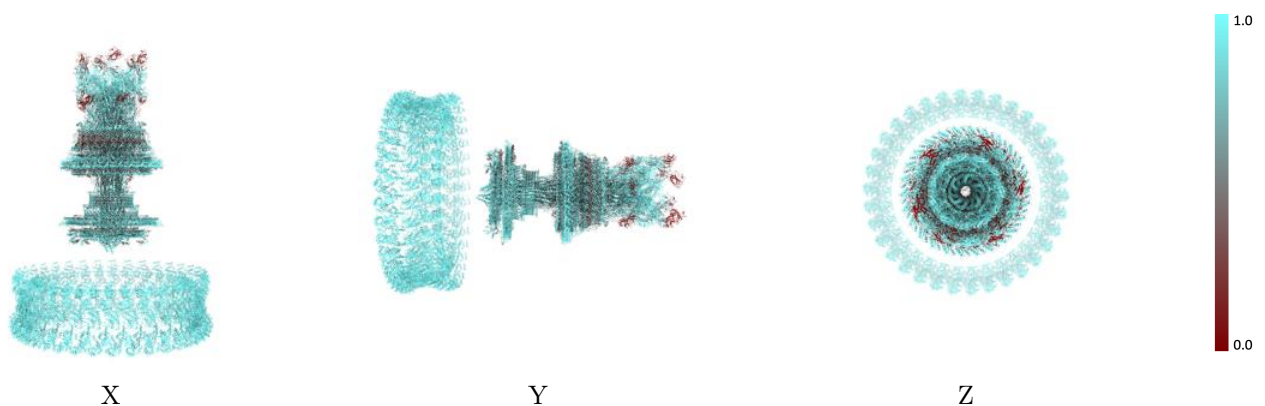

The images above show the model with each residue coloured according to its atom inclusion. This shows to what extent they are inside the map at the recommended contour level (0.05).



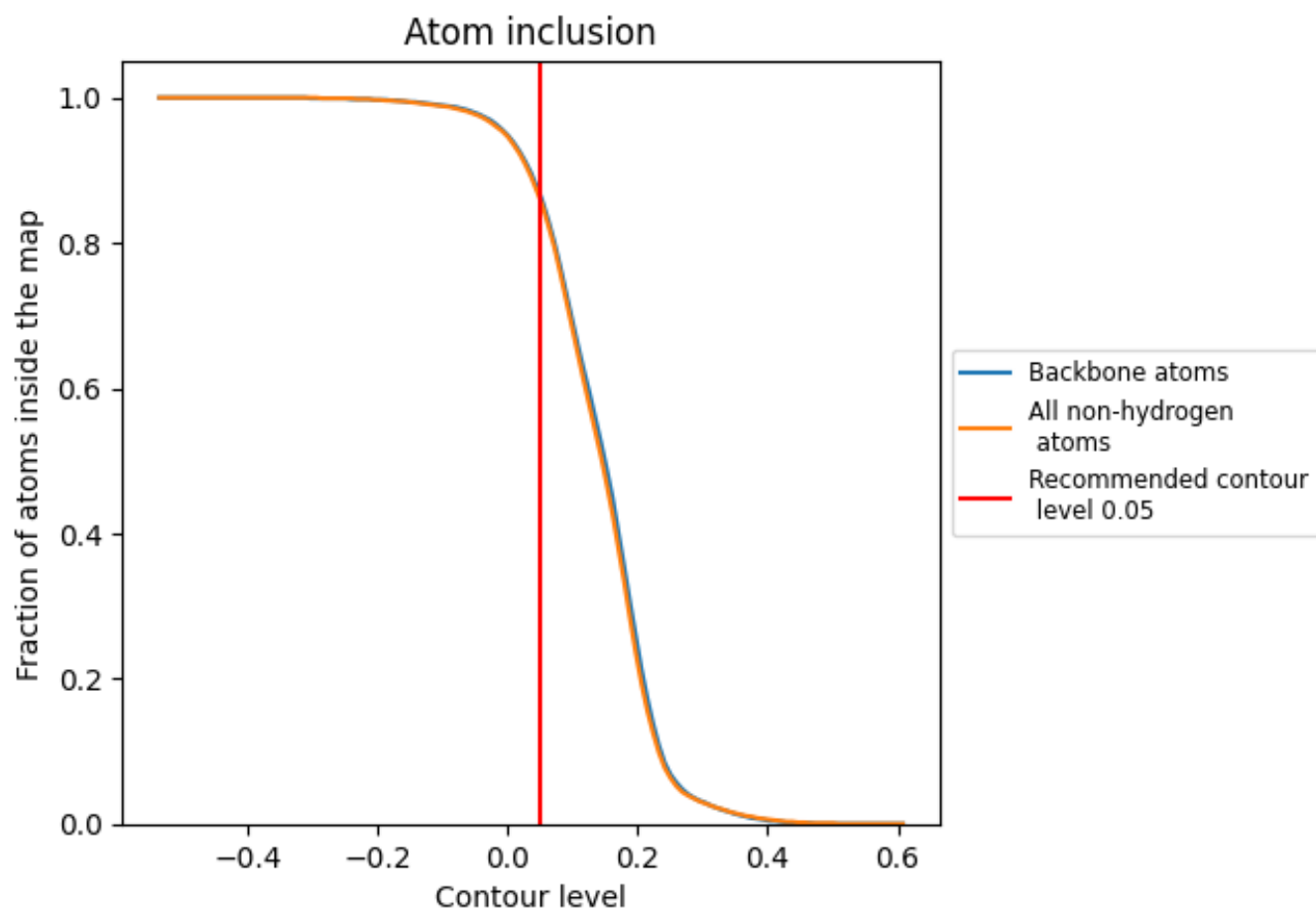



































































9.4 Atom inclusion [i](#)



At the recommended contour level, 86% of all backbone atoms, 86% of all non-hydrogen atoms, are inside the map.

9.5 Map-model fit summary

The table lists the average atom inclusion at the recommended contour level (0.05) and Q-score for the entire model and for each chain.

Chain	Atom inclusion	Q-score
All	 0.8590	 0.0430
0	 0.7170	 0.0180
1	 0.7610	 0.0370
2	 0.7570	 0.0390
3	 0.7340	 0.0320
4	 0.6870	 0.0250
5	 0.6840	 0.0200
6	 0.6950	 0.0420
7	 0.6990	 0.0360
8	 0.6780	 0.0300
9	 0.6590	 0.0250
A	 0.6940	 -0.0090
A0	 0.7210	 0.0380
A1	 0.7980	 0.0570
A2	 0.7710	 0.0690
A3	 0.6850	 0.0450
A4	 0.7360	 0.0850
A5	 0.8160	 0.1000
A6	 0.6100	 0.0700
A7	 0.6630	 0.0510
A8	 0.6310	 -0.0010
A9	 0.6230	 -0.0040
AA	 0.6360	 0.0280
AB	 0.6800	 0.0340
AC	 0.6880	 0.0180
AD	 0.6980	 0.0070
AE	 0.7110	 0.0250
AF	 0.7700	 0.0470
AG	 0.7710	 0.0510
AH	 0.7380	 0.0360
AI	 0.7140	 0.0160
AJ	 0.7220	 0.0220
AK	 0.7460	 0.0310
AL	 0.7460	 0.0370
AM	 0.7320	 0.0380



Continued on next page...

Continued from previous page...

Chain	Atom inclusion	Q-score
AN	0.6910	0.0160
AO	0.9130	0.1010
AP	0.9000	0.0900
AQ	0.8750	0.0730
AR	0.8820	0.0730
AS	0.7540	0.0040
AT	0.7510	0.0050
AU	0.7550	0.0070
AV	0.7670	0.0130
AW	0.7880	0.0190
AX	0.8100	0.0250
AY	0.8210	0.0330
AZ	0.8450	0.0450
Aa	0.8640	0.0590
Ab	0.9820	0.0000
Ac	0.9070	0.0860
Ad	0.9250	0.0970
Ae	0.9230	0.1020
Af	0.9260	0.1070
Ag	0.9250	0.1040
Ah	0.9240	0.0980
Ai	0.9210	0.0940
Aj	0.9210	0.0940
Ak	0.9220	0.0950
Al	0.9280	0.0990
Am	0.9260	0.1010
An	0.9290	0.1040
Ao	0.9300	0.1060
Ap	0.9300	0.1050
Aq	0.9970	0.0450
Ar	0.9900	0.0010
As	0.9770	0.0290
At	0.9080	0.0220
Au	0.8760	0.0190
Av	0.9260	0.0300
Aw	0.9460	0.0380
Ax	0.8700	0.0260
Ay	0.7880	0.0060
Az	0.8400	0.0610
B	0.6860	-0.0020
B0	0.9970	0.0690
B1	0.9970	0.0760







































Continued on next page...

Continued from previous page...

Chain	Atom inclusion	Q-score
B2	1.0000	0.0730
B3	0.9950	0.0790
B4	0.9950	0.0660
B5	0.9940	0.0800
B6	0.9770	0.0860
B7	0.9970	0.0750
B8	1.0000	0.0730
B9	0.9950	0.0790
BA	0.7660	0.0390
BB	0.7840	0.0580
BC	0.8180	0.0580
BD	0.7760	0.0470
BE	0.8030	0.0510
BF	0.8230	0.0510
BG	0.7780	0.0630
BH	0.6600	0.0360
BI	0.2780	-0.0440
BJ	0.6800	-0.0350
BK	0.4710	-0.0230
BL	0.7380	-0.0610
BM	0.6000	-0.0520
BN	0.7670	-0.0470
BO	0.7820	-0.0020
BP	0.7670	-0.0250
BQ	0.6430	-0.0010
BR	0.8570	0.0530
BS	0.8300	0.0390
BT	0.8150	0.0280
BU	0.8000	0.0190
BV	0.7860	0.0110
BW	0.7760	0.0090
BX	0.7630	0.0070
BY	0.9950	0.0800
BZ	0.9940	0.0660
Ba	0.9940	0.0800
Bb	0.9770	0.0880
Bc	0.9970	0.0740
Bd	0.9970	0.0740
Be	0.9950	0.0800
Bf	0.9940	0.0650
Bg	0.9930	0.0780
Bh	0.9770	0.0870





















































































Continued on next page...

Continued from previous page...

Chain	Atom inclusion	Q-score
Bi	 0.9970	 0.0750
Bj	 0.9950	 0.0730
Bk	 0.9950	 0.0800
Bl	 0.9920	 0.0630
Bm	 0.9930	 0.0780
Bn	 0.9770	 0.0880
Bo	 0.9970	 0.0760
Bp	 0.9970	 0.0730
Bq	 0.9970	 0.0820
Br	 0.9970	 0.0640
Bs	 0.9930	 0.0790
Bt	 0.9770	 0.0860
Bu	 0.9970	 0.0760
Bv	 0.9970	 0.0740
Bw	 0.9950	 0.0770
Bx	 0.9940	 0.0650
By	 0.9930	 0.0800
Bz	 0.9770	 0.0860
C	 0.7190	 0.0070
C0	 0.9950	 0.0740
C1	 0.9950	 0.0720
C2	 0.9970	 0.0580
C3	 0.9770	 0.0890
C4	 0.9950	 0.0750
C5	 0.9940	 0.0580
C6	 0.9930	 0.0790
C7	 0.9770	 0.0870
C8	 0.9970	 0.0740
C9	 0.9950	 0.0720
CA	 0.9940	 0.0810
CB	 0.9770	 0.0880
CC	 0.9970	 0.0730
CD	 0.9970	 0.0700
CE	 0.9950	 0.0790
CF	 0.9950	 0.0660
CG	 0.9930	 0.0800
CH	 0.9770	 0.0890
CI	 0.9970	 0.0740
CJ	 0.9970	 0.0700
CK	 0.9950	 0.0780
CL	 0.9920	 0.0660
CM	 0.9930	 0.0800





















































































Continued on next page...

Continued from previous page...

Chain	Atom inclusion	Q-score
CN	 0.9770	 0.0900
CO	 0.9970	 0.0740
CP	 0.9970	 0.0720
CQ	 0.9950	 0.0770
CR	 0.9940	 0.0630
CS	 0.9930	 0.0800
CT	 0.9770	 0.0870
CU	 0.9970	 0.0740
CV	 0.9970	 0.0710
CW	 0.9950	 0.0750
CX	 0.9920	 0.0640
CY	 0.9930	 0.0800
CZ	 0.9770	 0.0910
Ca	 0.9970	 0.0740
Cb	 0.9990	 0.0740
Cc	 0.9950	 0.0750
Cd	 0.9940	 0.0650
Ce	 0.9930	 0.0800
Cf	 0.9770	 0.0860
Cg	 0.9980	 0.0740
Ch	 0.9970	 0.0710
Ci	 0.9950	 0.0750
Cj	 0.9970	 0.0630
Ck	 0.9930	 0.0810
Cl	 0.9770	 0.0880
Cm	 0.9980	 0.0750
Cn	 0.9990	 0.0720
Co	 0.9950	 0.0740
Cp	 0.9950	 0.0610
Cq	 0.9930	 0.0810
Cr	 0.9770	 0.0880
Cs	 0.9980	 0.0740
Ct	 1.0000	 0.0710
Cu	 0.9950	 0.0750
Cv	 0.9970	 0.0600
Cw	 0.9930	 0.0790
Cx	 0.9770	 0.0870
Cy	 0.9970	 0.0730
Cz	 0.9970	 0.0710
D	 0.7040	 0.0010
D0	 0.9990	 0.0740
D1	 0.9930	 0.0810





















































































Continued on next page...

Continued from previous page...

Chain	Atom inclusion	Q-score
D2	 0.9770	 0.0840
D3	 0.9970	 0.0740
D4	 0.9970	 0.0720
D5	 0.9950	 0.0750
D6	 0.9920	 0.0580
D7	 0.9930	 0.0800
D8	 0.9770	 0.0910
D9	 0.9970	 0.0750
DA	 0.9920	 0.0560
DB	 0.9930	 0.0800
DC	 0.9990	 0.0740
DD	 0.9930	 0.0790
DE	 0.9770	 0.0850
DF	 0.9980	 0.0740
DG	 0.9970	 0.0730
DH	 0.9950	 0.0760
DI	 0.9970	 0.0610
DJ	 0.9930	 0.0790
DK	 0.9770	 0.0810
DL	 0.9980	 0.0740
DM	 0.9970	 0.0750
DN	 0.9970	 0.0730
DO	 0.9970	 0.0750
DP	 0.9970	 0.0560
DQ	 0.9930	 0.0800
DR	 0.9770	 0.0850
DS	 0.9970	 0.0750
DT	 0.9970	 0.0740
DU	 0.9950	 0.0730
DV	 0.9940	 0.0570
DW	 0.9930	 0.0800
DX	 0.9770	 0.0870
DY	 0.9970	 0.0740
DZ	 1.0000	 0.0710
Da	 0.9950	 0.0740
Db	 0.9950	 0.0570
Dc	 0.9940	 0.0790
Dd	 0.9770	 0.0830
De	 0.9970	 0.0740
Df	 1.0000	 0.0730
Dg	 0.9950	 0.0760
Dh	 0.9970	 0.0580





















































































Continued on next page...

Continued from previous page...

Chain	Atom inclusion	Q-score
Di	 0.9940	 0.0800
Dj	 0.9770	 0.0850
Dk	 0.9970	 0.0740
Dl	 0.9970	 0.0730
Dm	 0.9950	 0.0760
Dn	 0.9950	 0.0550
Do	 0.9930	 0.0790
Dp	 0.9770	 0.0860
Dq	 0.9970	 0.0730
Dr	 0.9990	 0.0750
Ds	 0.9950	 0.0750
Dt	 0.9920	 0.0570
Du	 0.9930	 0.0790
Dv	 0.9770	 0.0830
Dw	 0.9970	 0.0740
Dx	 0.9970	 0.0750
Dy	 0.9950	 0.0770
Dz	 0.9940	 0.0570
E	 0.6970	 -0.0030
EA	 0.9950	 0.0750
EB	 0.9940	 0.0590
EC	 0.9950	 0.0780
ED	 0.9950	 0.0610
EE	 0.9930	 0.0790
EF	 0.9770	 0.0850
EG	 0.9980	 0.0740
EH	 1.0000	 0.0730
EI	 0.9950	 0.0810
EJ	 0.9970	 0.0610
EK	 0.9930	 0.0790
EL	 0.9770	 0.0850
EM	 0.9970	 0.0740
EN	 0.9970	 0.0750
EO	 0.9950	 0.0800
EP	 0.9970	 0.0620
EQ	 0.9930	 0.0790
ER	 0.9770	 0.0850
ES	 0.9980	 0.0740
ET	 1.0000	 0.0740
EU	 0.9950	 0.0800
EV	 0.9950	 0.0640
EW	 0.9930	 0.0800





















































































Continued on next page...

Continued from previous page...

Chain	Atom inclusion	Q-score
EX	 0.9770	 0.0860
EY	 0.9970	 0.0740
EZ	 0.9970	 0.0740
Ea	 0.9930	 0.0800
Eb	 0.9770	 0.0880
Ec	 0.9980	 0.0730
Ed	 1.0000	 0.0720
Ee	 0.9950	 0.0740
Ef	 0.9950	 0.0590
Eg	 0.9930	 0.0790
Eh	 0.9770	 0.0850
Ei	 0.9970	 0.0730
Ej	 0.9970	 0.0720
Ek	 0.9950	 0.0720
El	 0.9940	 0.0610
Em	 0.9940	 0.0800
En	 0.9770	 0.0860
Eo	 0.9970	 0.0750
Ep	 0.9970	 0.0720
F	 0.7120	 0.0030
G	 0.6990	 -0.0030
H	 0.6910	 -0.0120
I	 0.6700	 -0.0170
J	 0.6700	 -0.0170
K	 0.6630	 -0.0300
L	 0.6410	 -0.0370
M	 0.6260	 -0.0320
N	 0.6150	 -0.0390
O	 0.5980	 -0.0470
P	 0.6190	 -0.0380
Q	 0.6000	 -0.0400
R	 0.5940	 -0.0480
S	 0.6030	 -0.0420
T	 0.6100	 -0.0420
U	 0.6080	 -0.0500
UI	 0.6650	 -0.0450
UJ	 0.6400	 -0.0520
UK	 0.6640	 -0.0480
UL	 0.6590	 -0.0440
UM	 0.8510	 0.0160
UN	 0.8150	 0.0450
UO	 0.7780	 0.0210





















































































Continued on next page...

Continued from previous page...

Chain	Atom inclusion	Q-score
UP	 0.6750	 -0.0370
V	 0.6260	 -0.0390
W	 0.6440	 -0.0310
WA	 0.7880	 -0.0090
WB	 0.8100	 -0.0250
WC	 0.8050	 -0.0070
WD	 0.7790	 -0.0300
WE	 0.7440	 -0.0310
WF	 0.7410	 -0.0450
WG	 0.7740	 -0.0190
WH	 0.7500	 -0.0220
WI	 0.7240	 -0.0050
WJ	 0.7820	 0.0170
WK	 0.8440	 0.0470
WL	 0.9360	 0.0870
WM	 0.9280	 0.0500
WN	 0.9090	 0.0130
WO	 0.8520	 -0.0100
WP	 0.8600	 0.0070
WQ	 0.8980	 0.0350
WR	 0.9190	 0.0650
WS	 0.9270	 0.0850
WT	 0.9020	 0.0880
WU	 0.8910	 0.0510
WV	 0.8540	 0.0140
WW	 0.8570	 0.0130
X	 0.6480	 -0.0350
Y	 0.6630	 -0.0200
Z	 0.6780	 -0.0100
ZA	 0.6510	 0.0230
ZB	 0.6780	 0.0340
ZC	 0.7270	 0.0340
ZD	 0.7520	 0.0390
ZE	 0.7340	 0.0240
ZF	 0.4700	 0.0050
ZG	 0.5140	 0.0190
ZH	 0.5380	 0.0170
ZI	 0.5800	 0.0250
ZJ	 0.6450	 0.0240
ZK	 0.6950	 0.0050
ZL	 0.7360	 0.0140
ZM	 0.7700	 0.0180











Continued on next page...

Continued from previous page...

Chain	Atom inclusion	Q-score
ZN	 0.8160	 0.0320
ZO	 0.8390	 0.0320
ZP	 0.8440	 0.0150
ZQ	 0.8500	 0.0060
ZR	 0.8690	 0.0250
ZS	 0.8750	 0.0160
ZT	 0.8940	 0.0220
ZU	 0.9000	 0.0250
ZV	 0.8910	 0.0120
ZW	 0.8970	 0.0100
ZX	 0.8850	 0.0100
ZY	 0.8750	 0.0210
ZZ	 0.8520	 0.0160
Za	 0.8210	 0.0070
Zb	 0.7820	 -0.0030
Zc	 0.7430	 0.0000
Zd	 0.7170	 0.0130
Ze	 0.6840	 0.0140
Zf	 0.6510	 0.0160
Zg	 0.6240	 0.0090
Zh	 0.6060	 0.0060
a	 0.8530	 0.0460
b	 0.8590	 0.0460
c	 0.8510	 0.0480
d	 0.8450	 0.0410
e	 0.8330	 0.0410
f	 0.8250	 0.0330
g	 0.8040	 0.0190
h	 0.7890	 0.0180
i	 0.7860	 0.0090
j	 0.7530	 -0.0010
k	 0.7490	 0.0010
l	 0.7530	 -0.0040
m	 0.7340	 -0.0080
n	 0.7310	 -0.0050
o	 0.7360	 -0.0050
p	 0.7370	 -0.0080
q	 0.7510	 -0.0060
r	 0.7670	 0.0000
s	 0.7800	 0.0010
t	 0.7750	 0.0050
u	 0.8050	 0.0180

Continued on next page...

Continued from previous page...

Chain	Atom inclusion	Q-score
v	 0.8130	 0.0200
w	 0.8170	 0.0250
x	 0.8350	 0.0350
y	 0.8500	 0.0370
z	 0.8540	 0.0410