



## Full wwPDB EM Validation Report ⓘ

Sep 28, 2024 – 10:39 pm BST

PDB ID : 2XFB  
EMDB ID : EMD-1121  
Title : CHIKUNGUNYA E1 E2 ENVELOPE GLYCOPROTEINS FITTED IN  
SINDBIS VIRUS cryo- EM MAP  
Authors : Voss, J.E.; Vaney, M.C.; Duquerroy, S.; Rey, F.A.  
Deposited on : 2010-05-21  
Resolution : 9.00 Å(reported)  
Based on initial model : 3N40

This is a Full wwPDB EM Validation Report for a publicly released PDB entry.

We welcome your comments at [validation@mail.wwpdb.org](mailto:validation@mail.wwpdb.org)

A user guide is available at

<https://www.wwpdb.org/validation/2017/EMValidationReportHelp>

with specific help available everywhere you see the ⓘ symbol.

The types of validation reports are described at

<http://www.wwpdb.org/validation/2017/FAQs#types>.

---

The following versions of software and data (see [references ⓘ](#)) were used in the production of this report:

EMDB validation analysis : 0.0.1.dev113  
MolProbity : 4.02b-467  
Percentile statistics : 20231227.v01 (using entries in the PDB archive December 27th 2023)  
MapQ : 1.9.13  
Ideal geometry (proteins) : Engh & Huber (2001)  
Ideal geometry (DNA, RNA) : Parkinson et al. (1996)  
Validation Pipeline (wwPDB-VP) : 2.39

# 1 Overall quality at a glance i

The following experimental techniques were used to determine the structure:

*ELECTRON MICROSCOPY*

The reported resolution of this entry is 9.00 Å.

Percentile scores (ranging between 0-100) for global validation metrics of the entry are shown in the following graphic. The table shows the number of entries on which the scores are based.

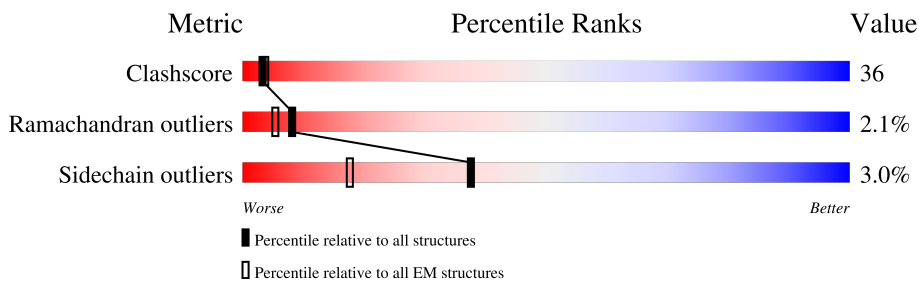

Metric	Whole archive (#Entries)	EM structures (#Entries)
Clashscore	210492	15764
Ramachandran outliers	207382	16835
Sidechain outliers	206894	16415

The table below summarises the geometric issues observed across the polymeric chains and their fit to the map. The red, orange, yellow and green segments of the bar indicate the fraction of residues that contain outliers for  $\geq 3$ , 2, 1 and 0 types of geometric quality criteria respectively. A grey segment represents the fraction of residues that are not modelled. The numeric value for each fraction is indicated below the corresponding segment, with a dot representing fractions  $\leq 5\%$ . The upper red bar (where present) indicates the fraction of residues that have poor fit to the EM map (all-atom inclusion  $< 40\%$ ). The numeric value is given above the bar.

Mol	Chain	Length	Quality of chain
1	A	391	
1	D	391	
1	F	391	
1	H	391	
2	B	334	
2	E	334	
2	G	334	
2	I	334	

## 2 Entry composition [i](#)

There are 2 unique types of molecules in this entry. The entry contains 22460 atoms, of which 0 are hydrogens and 0 are deuteriums.

In the tables below, the AltConf column contains the number of residues with at least one atom in alternate conformation and the Trace column contains the number of residues modelled with at most 2 atoms.

- Molecule 1 is a protein called E1 ENVELOPE GLYCOPROTEIN.

Mol	Chain	Residues	Atoms					AltConf	Trace
			Total	C	N	O	S		
1	A	391	2981	1886	499	572	24	0	0
1	D	391	2981	1886	499	572	24	0	0
1	F	391	2981	1886	499	572	24	0	0
1	H	391	2981	1886	499	572	24	0	0

- Molecule 2 is a protein called E2 ENVELOPE GLYCOPROTEIN.

Mol	Chain	Residues	Atoms					AltConf	Trace
			Total	C	N	O	S		
2	B	334	2634	1643	477	494	20	0	0
2	E	334	2634	1643	477	494	20	0	0
2	G	334	2634	1643	477	494	20	0	0
2	I	334	2634	1643	477	494	20	0	0

### 3 Residue-property plots

These plots are drawn for all protein, RNA, DNA and oligosaccharide chains in the entry. The first graphic for a chain summarises the proportions of the various outlier classes displayed in the second graphic. The second graphic shows the sequence view annotated by issues in geometry and atom inclusion in map density. Residues are color-coded according to the number of geometric quality criteria for which they contain at least one outlier: green = 0, yellow = 1, orange = 2 and red = 3 or more. A red diamond above a residue indicates a poor fit to the EM map for this residue (all-atom inclusion < 40%). Stretches of 2 or more consecutive residues without any outlier are shown as a green connector. Residues present in the sample, but not in the model, are shown in grey.

- Molecule 1: E1 ENVELOPE GLYCOPROTEIN

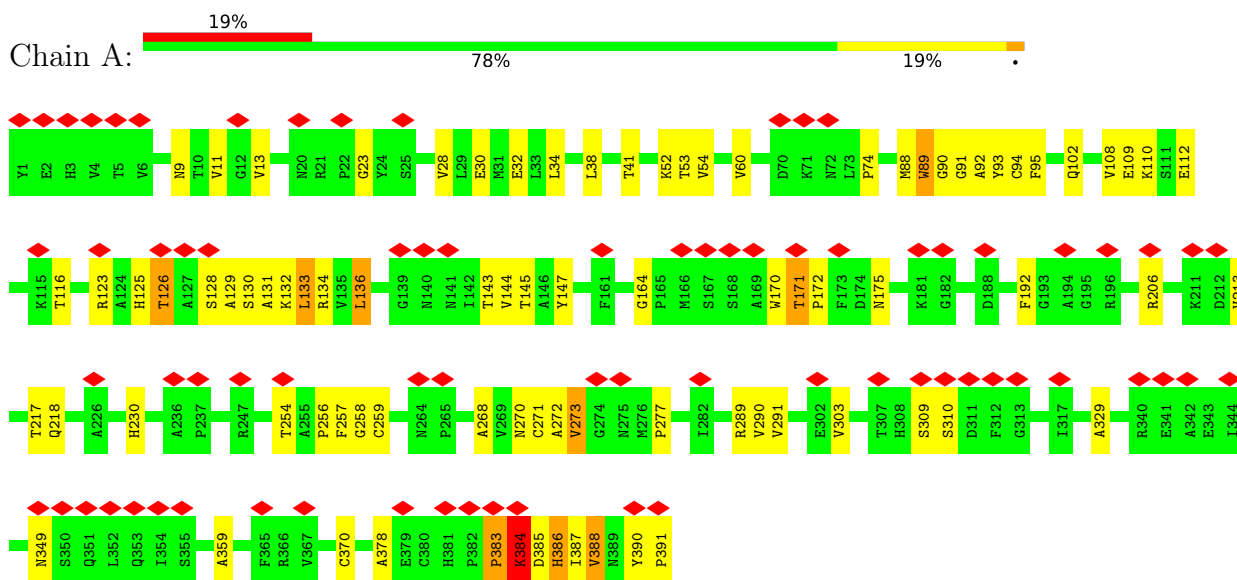

- Molecule 1: E1 ENVELOPE GLYCOPROTEIN

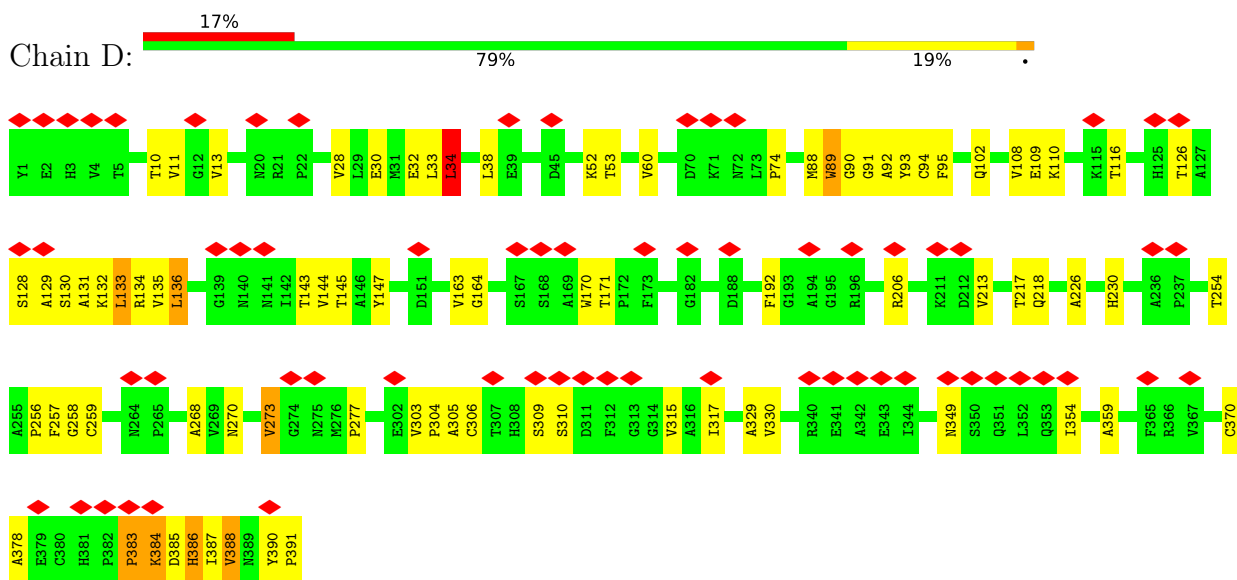

- Molecule 1: E1 ENVELOPE GLYCOPROTEIN

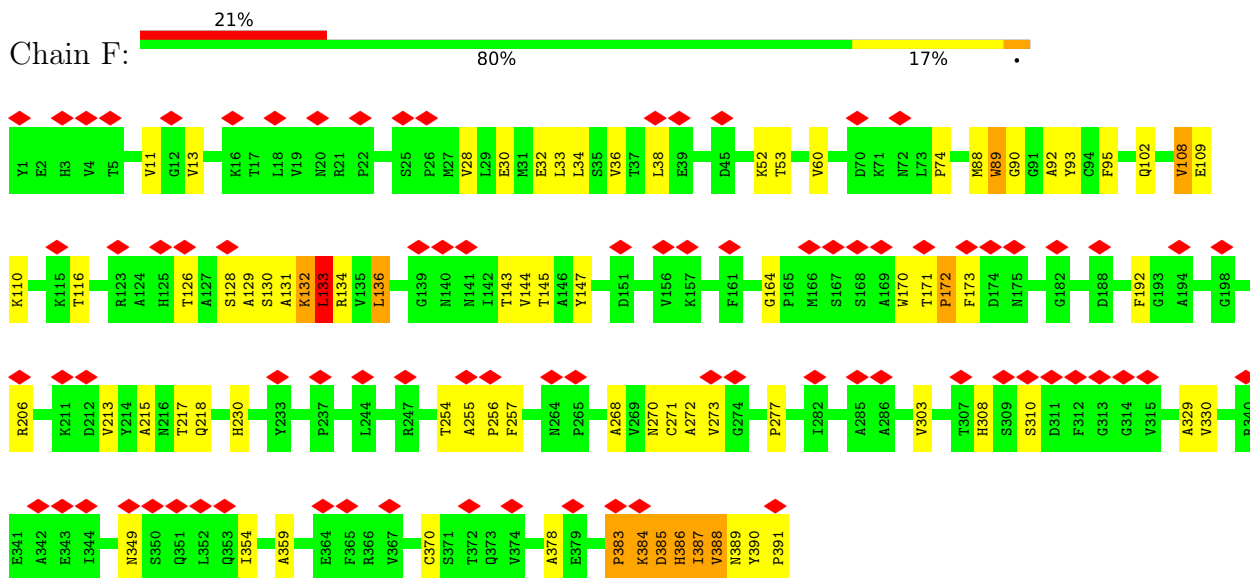

• Molecule 1: E1 ENVELOPE GLYCOPROTEIN

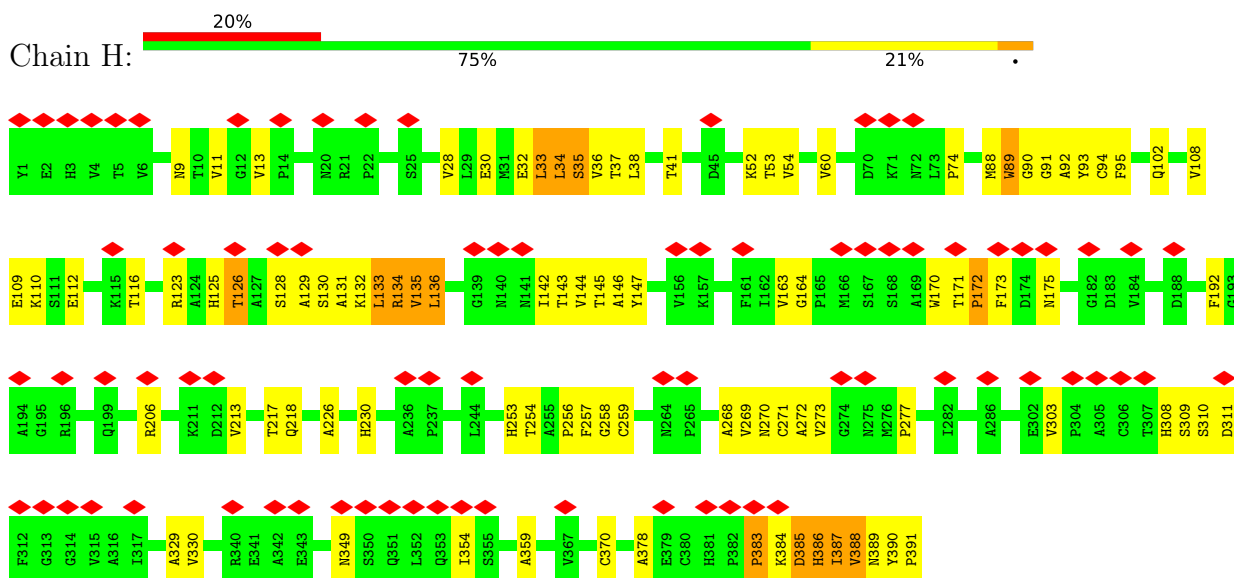

• Molecule 2: E2 ENVELOPE GLYCOPROTEIN

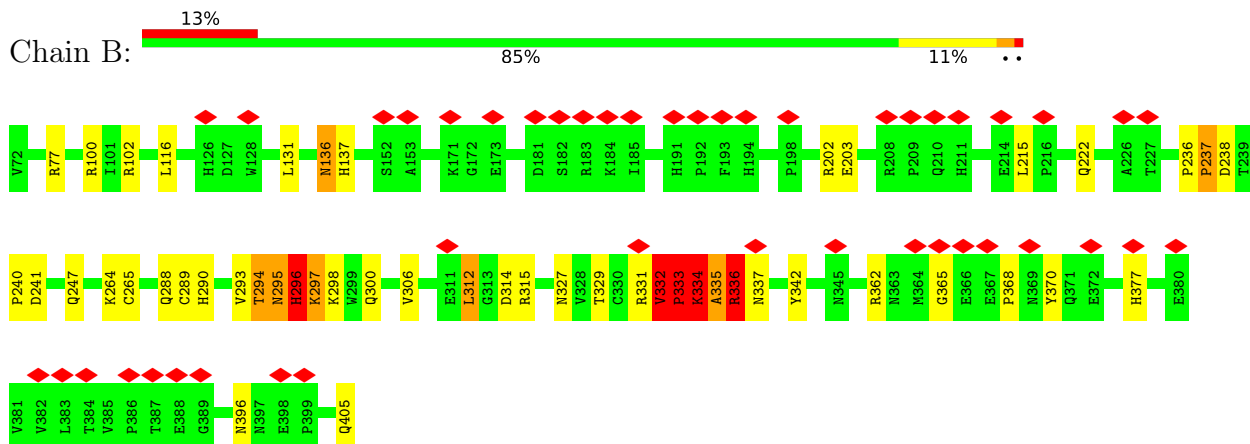

• Molecule 2: E2 ENVELOPE GLYCOPROTEIN

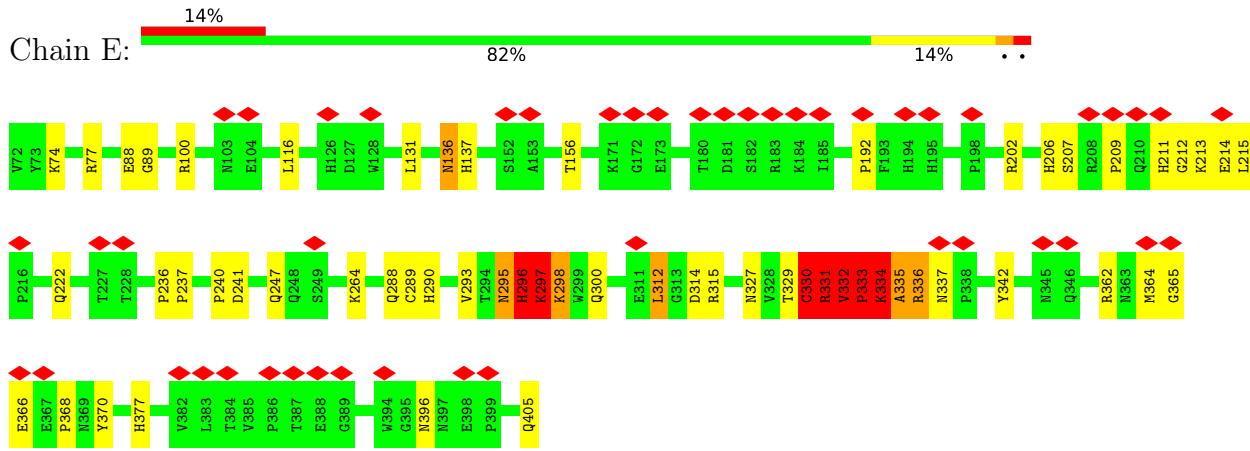

• Molecule 2: E2 ENVELOPE GLYCOPROTEIN

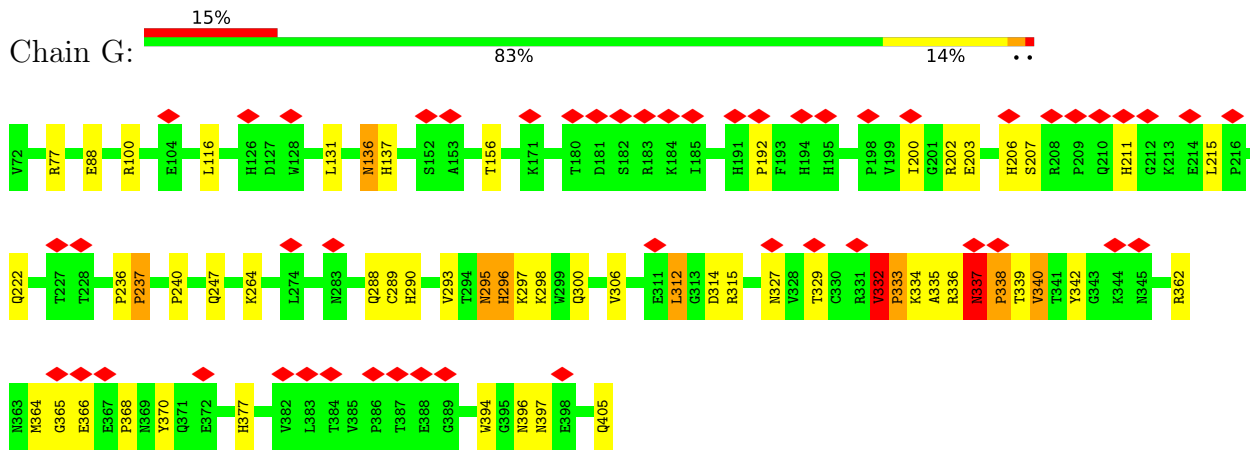

• Molecule 2: E2 ENVELOPE GLYCOPROTEIN

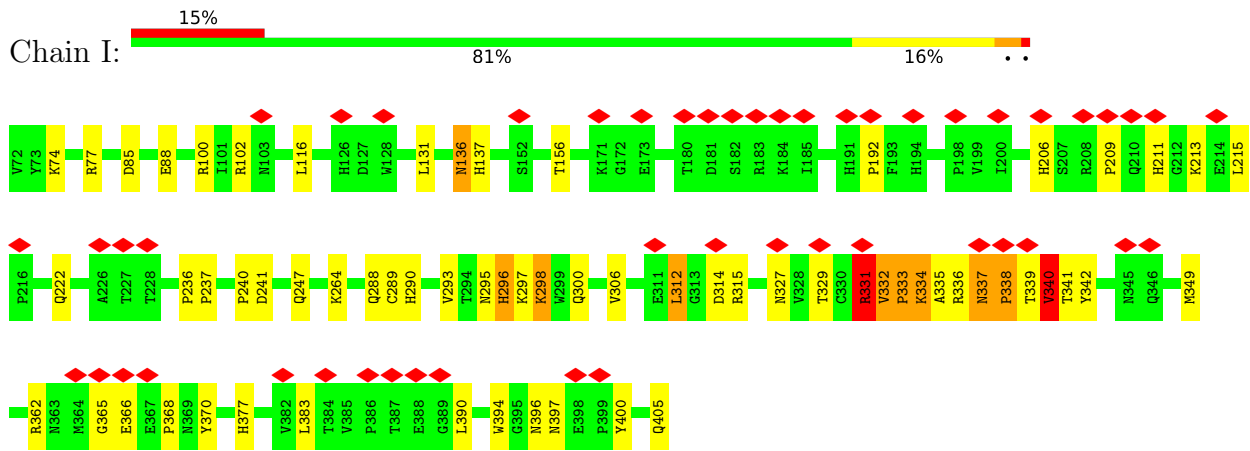

## 4 Experimental information

Property	Value	Source
EM reconstruction method	SINGLE PARTICLE	Depositor
Imposed symmetry	POINT, I	Depositor
Number of particles used	7085	Depositor
Resolution determination method	Not provided	
CTF correction method	Not provided	
Microscope	FEI/PHILIPS CM200T	Depositor
Voltage (kV)	100	Depositor
Electron dose ( $e^-/\text{\AA}^2$ )	18	Depositor
Minimum defocus (nm)	1100	Depositor
Maximum defocus (nm)	2580	Depositor
Magnification	38000	Depositor
Image detector	KODAK SO-163 FILM	Depositor
Maximum map value	402.470	Depositor
Minimum map value	-297.650	Depositor
Average map value	7.032	Depositor
Map value standard deviation	65.091	Depositor
Recommended contour level	138	Depositor
Map size ( $\text{\AA}$ )	787.18, 787.18, 787.18	wwPDB
Map dimensions	441, 441, 441	wwPDB
Map angles ( $^\circ$ )	90, 90, 90	wwPDB
Pixel spacing ( $\text{\AA}$ )	1.78499, 1.78499, 1.78499	Depositor

## 5 Model quality i

### 5.1 Standard geometry i

The Z score for a bond length (or angle) is the number of standard deviations the observed value is removed from the expected value. A bond length (or angle) with  $|Z| > 5$  is considered an outlier worth inspection. RMSZ is the root-mean-square of all Z scores of the bond lengths (or angles).

Mol	Chain	Bond lengths		Bond angles	
		RMSZ	# Z  >5	RMSZ	# Z  >5
1	A	0.56	1/3053 (0.0%)	0.77	4/4157 (0.1%)
1	D	0.37	1/3054 (0.0%)	0.88	4/4160 (0.1%)
1	F	0.62	1/3053 (0.0%)	0.59	1/4157 (0.0%)
1	H	0.34	0/3054	0.57	0/4160
2	B	0.57	9/2705 (0.3%)	0.69	7/3682 (0.2%)
2	E	0.48	2/2704 (0.1%)	0.66	7/3678 (0.2%)
2	G	0.38	0/2705	0.63	2/3682 (0.1%)
2	I	0.35	0/2704	0.60	2/3678 (0.1%)
All	All	0.47	14/23032 (0.1%)	0.68	27/31354 (0.1%)

Chiral center outliers are detected by calculating the chiral volume of a chiral center and verifying if the center is modelled as a planar moiety or with the opposite hand. A planarity outlier is detected by checking planarity of atoms in a peptide group, atoms in a mainchain group or atoms of a sidechain that are expected to be planar.

Mol	Chain	#Chirality outliers	#Planarity outliers
1	A	0	2
1	D	0	2
2	E	0	1
All	All	0	5

All (14) bond length outliers are listed below:

Mol	Chain	Res	Type	Atoms	Z	Observed(Å)	Ideal(Å)
1	F	108	VAL	C-N	28.82	2.00	1.34
1	A	171	THR	C-N	-23.03	0.90	1.34
2	B	333	PRO	CA-C	8.69	1.70	1.52
2	B	336	ARG	N-CA	7.42	1.61	1.46
2	B	335	ALA	N-CA	7.36	1.61	1.46
2	B	334	LYS	N-CA	7.32	1.60	1.46
2	B	332	VAL	CA-C	6.78	1.70	1.52
2	B	335	ALA	CA-C	6.73	1.70	1.52
2	B	334	LYS	CA-C	6.70	1.70	1.52

*Continued on next page...*



*Continued from previous page...*

Mol	Chain	Res	Type	Atoms	Z	Observed(Å)	Ideal(Å)
2	B	332	VAL	N-CA	6.56	1.59	1.46
2	B	336	ARG	CA-C	6.27	1.69	1.52
2	E	333	PRO	CA-C	5.83	1.64	1.52
1	D	171	THR	C-N	-5.18	1.24	1.34
2	E	331	ARG	N-CA	5.06	1.56	1.46

All (27) bond angle outliers are listed below:

Mol	Chain	Res	Type	Atoms	Z	Observed(°)	Ideal(°)
1	D	171	THR	O-C-N	27.45	173.25	121.10
1	D	171	THR	C-N-CD	23.30	177.34	128.40
1	A	171	THR	O-C-N	19.99	159.09	121.10
1	D	171	THR	CA-C-N	-17.56	67.94	117.10
1	A	171	THR	C-N-CD	17.28	164.68	128.40
1	A	171	THR	CA-C-N	-14.70	75.95	117.10
1	D	171	THR	C-N-CA	-12.38	69.99	122.00
1	A	171	THR	C-N-CA	-10.90	76.20	122.00
2	B	333	PRO	N-CA-C	7.27	131.00	112.10
2	B	335	ALA	N-CA-C	7.24	130.54	111.00
2	B	334	LYS	N-CA-C	7.10	130.18	111.00
2	B	332	VAL	C-N-CD	-6.87	105.50	120.60
2	E	330	CYS	O-C-N	-6.86	111.72	122.70
1	F	108	VAL	O-C-N	-6.50	112.31	122.70
2	E	332	VAL	C-N-CD	-6.42	106.49	120.60
2	B	331	ARG	C-N-CA	6.41	137.72	121.70
2	B	336	ARG	N-CA-C	6.28	127.96	111.00
2	E	331	ARG	N-CA-C	5.83	126.75	111.00
2	G	337	ASN	C-N-CD	-5.55	108.39	120.60
2	E	335	ALA	N-CA-C	5.54	125.97	111.00
2	B	332	VAL	N-CA-C	5.48	125.78	111.00
2	G	332	VAL	C-N-CD	-5.41	108.69	120.60
2	E	332	VAL	N-CA-C	5.35	125.45	111.00
2	E	334	LYS	N-CA-C	5.21	125.06	111.00
2	E	333	PRO	N-CA-C	5.16	125.53	112.10
2	I	337	ASN	C-N-CD	-5.05	109.49	120.60
2	I	332	VAL	C-N-CD	-5.01	109.58	120.60

There are no chirality outliers.

All (5) planarity outliers are listed below:

Mol	Chain	Res	Type	Group
1	A	383	PRO	Mainchain,Peptide

*Continued on next page...*

Continued from previous page...

Mol	Chain	Res	Type	Group
1	D	383	PRO	Mainchain,Peptide
2	E	330	CYS	Mainchain

## 5.2 Too-close contacts [i](#)

In the following table, the Non-H and H(model) columns list the number of non-hydrogen atoms and hydrogen atoms in the chain respectively. The H(added) column lists the number of hydrogen atoms added and optimized by MolProbity. The Clashes column lists the number of clashes within the asymmetric unit, whereas Symm-Clashes lists symmetry-related clashes.

Mol	Chain	Non-H	H(model)	H(added)	Clashes	Symm-Clashes
1	A	2981	0	2877	385	0
1	D	2981	0	2879	308	0
1	F	2981	0	2877	298	0
1	H	2981	0	2880	374	0
2	B	2634	0	2556	176	0
2	E	2634	0	2554	168	0
2	G	2634	0	2553	179	0
2	I	2634	0	2550	255	0
All	All	22460	0	21726	1595	0

The all-atom clashscore is defined as the number of clashes found per 1000 atoms (including hydrogen atoms). The all-atom clashscore for this structure is 36.

All (1595) close contacts within the same asymmetric unit are listed below, sorted by their clash magnitude.

Atom-1	Atom-2	Interatomic distance (Å)	Clash overlap (Å)
1:A:125:HIS:CE1	1:H:41:THR:HB	1.27	1.67
1:A:41:THR:HB	1:H:125:HIS:CE1	1.26	1.67
1:D:132:LYS:CB	1:D:145:THR:HA	1.25	1.64
1:F:256:PRO:HG3	2:G:368:PRO:CG	1.28	1.63
1:H:257:PHE:CZ	2:I:366:GLU:HA	1.14	1.63
1:A:132:LYS:HB2	1:A:145:THR:CA	1.19	1.60
1:H:257:PHE:CE2	2:I:366:GLU:HA	1.07	1.60
1:A:257:PHE:CG	1:A:273:VAL:CB	1.85	1.59
1:A:257:PHE:CE2	1:A:273:VAL:HG23	1.24	1.59
1:A:132:LYS:CB	1:A:145:THR:HA	1.20	1.59
1:D:170:TRP:CH2	1:D:256:PRO:HD2	1.37	1.59
1:H:132:LYS:CA	1:H:145:THR:HA	1.19	1.58
1:D:34:LEU:CB	1:D:133:LEU:HA	1.18	1.58

Continued on next page...

*Continued from previous page...*

Atom-1	Atom-2	Interatomic distance (Å)	Clash overlap (Å)
1:F:34:LEU:CD1	1:F:143:THR:HG23	1.12	1.57
1:A:256:PRO:HB3	2:B:368:PRO:CD	1.24	1.56
1:F:256:PRO:HG3	2:G:368:PRO:CD	1.26	1.56
1:A:385:ASP:CG	2:B:342:TYR:CD1	1.78	1.55
1:D:34:LEU:CD1	1:D:143:THR:HG23	1.28	1.55
1:D:257:PHE:CZ	1:D:273:VAL:CG2	1.83	1.55
1:F:13:VAL:CG2	1:F:391:PRO:HG2	1.23	1.55
1:A:13:VAL:HG22	1:A:391:PRO:CG	1.29	1.54
1:A:256:PRO:CG	2:B:368:PRO:HG3	1.21	1.54
1:D:257:PHE:CZ	1:D:273:VAL:HG23	1.33	1.54
1:H:132:LYS:HA	1:H:145:THR:CA	1.31	1.54
1:D:34:LEU:HB2	1:D:133:LEU:CA	1.34	1.53
1:A:256:PRO:CB	2:B:368:PRO:HD3	1.33	1.52
1:A:256:PRO:HG3	2:B:368:PRO:CG	1.26	1.52
1:D:132:LYS:HB2	1:D:145:THR:CA	1.14	1.52
1:H:257:PHE:CE2	2:I:366:GLU:CA	1.86	1.52
1:F:95:PHE:CD1	2:G:264:LYS:O	1.64	1.50
1:A:289:ARG:HB3	1:D:305:ALA:CB	1.03	1.49
1:H:258:GLY:HA2	2:I:362:ARG:CZ	1.40	1.49
1:D:13:VAL:HG22	1:D:391:PRO:CG	1.05	1.49
1:A:132:LYS:HG3	1:A:144:VAL:C	1.26	1.49
1:F:13:VAL:HG22	1:F:391:PRO:CG	1.38	1.48
1:F:34:LEU:CD2	1:F:134:ARG:HB2	1.44	1.47
1:A:34:LEU:CD1	1:A:143:THR:HG23	1.00	1.47
1:H:257:PHE:CZ	1:H:273:VAL:HG23	1.51	1.46
1:A:41:THR:CB	1:H:125:HIS:HE1	1.28	1.45
1:A:257:PHE:CD2	1:A:273:VAL:HB	1.51	1.45
1:D:13:VAL:CG2	1:D:391:PRO:HG2	1.46	1.45
1:F:257:PHE:CB	1:F:272:ALA:C	1.81	1.45
1:A:95:PHE:HA	2:B:290:HIS:CB	1.46	1.45
1:D:132:LYS:HG3	1:D:144:VAL:C	1.18	1.45
1:F:256:PRO:CG	2:G:368:PRO:HD3	1.46	1.44
1:A:34:LEU:CD1	1:A:143:THR:CG2	1.95	1.44
1:F:34:LEU:HG	1:F:133:LEU:C	1.10	1.44
1:A:170:TRP:CH2	1:A:256:PRO:HD2	1.52	1.44
1:H:257:PHE:CZ	1:H:273:VAL:CG2	1.97	1.44
1:A:256:PRO:CG	2:B:368:PRO:CG	1.80	1.43
1:D:34:LEU:HG	1:D:133:LEU:C	1.07	1.43
1:D:132:LYS:CG	1:D:144:VAL:C	1.86	1.43
1:A:13:VAL:CG2	1:A:391:PRO:HG2	1.45	1.42
1:H:34:LEU:HD12	1:H:132:LYS:CG	1.47	1.42

*Continued on next page...*

*Continued from previous page...*

Atom-1	Atom-2	Interatomic distance (Å)	Clash overlap (Å)
1:A:257:PHE:CG	1:A:273:VAL:HB	0.91	1.42
2:E:213:LYS:CD	2:E:333:PRO:HD2	1.47	1.41
1:F:34:LEU:N	1:F:133:LEU:CA	1.79	1.41
1:H:34:LEU:CD1	1:H:132:LYS:HG2	1.50	1.41
1:A:95:PHE:CD1	2:B:289:CYS:HA	1.55	1.40
1:D:13:VAL:CG2	1:D:391:PRO:CG	1.93	1.40
1:A:125:HIS:HE1	1:H:41:THR:CB	1.30	1.40
1:A:256:PRO:CB	2:B:368:PRO:CG	1.96	1.39
1:A:289:ARG:CB	1:D:305:ALA:CB	1.96	1.39
1:F:34:LEU:CD1	1:F:143:THR:CG2	2.00	1.39
2:E:332:VAL:HG12	2:E:333:PRO:CD	1.50	1.39
2:E:156:THR:CG2	2:I:88:GLU:CD	1.90	1.38
1:A:256:PRO:CB	2:B:368:PRO:CD	1.89	1.38
1:F:257:PHE:HB3	1:F:272:ALA:C	1.03	1.38
1:A:257:PHE:CE2	1:A:273:VAL:CG2	2.05	1.37
1:H:132:LYS:CG	1:H:145:THR:OG1	1.70	1.37
1:A:95:PHE:CA	2:B:290:HIS:HB2	1.52	1.37
1:A:257:PHE:CD2	1:A:273:VAL:CB	2.05	1.37
1:F:11:VAL:CG2	1:F:270:ASN:HB3	1.54	1.37
1:F:13:VAL:CG2	1:F:391:PRO:CG	1.95	1.37
1:D:257:PHE:CE2	1:D:273:VAL:HG23	1.27	1.36
1:D:95:PHE:HA	2:E:290:HIS:CB	1.54	1.35
1:D:132:LYS:HB2	1:D:145:THR:CB	1.54	1.35
1:H:13:VAL:HG22	1:H:391:PRO:CG	1.54	1.35
1:H:257:PHE:CZ	2:I:366:GLU:CA	2.04	1.35
1:F:11:VAL:HG21	1:F:270:ASN:CB	1.54	1.35
1:D:34:LEU:CG	1:D:133:LEU:C	1.96	1.34
1:H:11:VAL:CG2	1:H:33:LEU:CD1	2.05	1.34
1:H:95:PHE:HA	2:I:290:HIS:CB	1.55	1.34
1:D:34:LEU:HD11	1:D:143:THR:CG2	1.55	1.34
1:F:257:PHE:CZ	2:G:366:GLU:HA	1.63	1.34
1:D:132:LYS:HD3	1:D:143:THR:CG2	1.56	1.34
1:A:170:TRP:CZ2	1:A:256:PRO:HD2	1.61	1.33
1:H:310:SER:N	1:H:388:VAL:CG2	1.89	1.33
1:H:52:LYS:HE3	2:I:100:ARG:CZ	1.57	1.33
2:I:213:LYS:CG	2:I:332:VAL:CG1	1.93	1.33
1:A:257:PHE:CZ	1:A:273:VAL:CG2	2.13	1.32
1:A:289:ARG:CB	1:D:305:ALA:HB2	1.56	1.32
1:D:256:PRO:CA	2:E:368:PRO:HB3	1.45	1.32
1:H:257:PHE:CE2	1:H:273:VAL:CG2	2.06	1.32
1:A:34:LEU:N	1:A:133:LEU:HA	1.44	1.32

*Continued on next page...*

*Continued from previous page...*

Atom-1	Atom-2	Interatomic distance (Å)	Clash overlap (Å)
1:A:385:ASP:OD1	2:B:342:TYR:CE1	1.80	1.32
1:A:385:ASP:CG	2:B:342:TYR:HD1	1.16	1.32
1:H:11:VAL:CG2	1:H:33:LEU:HD13	1.58	1.32
1:A:34:LEU:HG	1:A:133:LEU:C	1.51	1.31
1:A:95:PHE:CE1	2:B:289:CYS:HA	1.64	1.31
2:I:340:VAL:CG2	2:I:341:THR:H	1.27	1.31
1:F:132:LYS:CA	1:F:144:VAL:O	1.75	1.31
1:F:170:TRP:CH2	1:F:256:PRO:HD2	1.64	1.31
1:A:257:PHE:CE1	1:A:273:VAL:HG21	1.64	1.31
1:D:34:LEU:HG	1:D:133:LEU:CA	1.59	1.30
1:A:130:SER:HB2	1:A:147:TYR:CE1	1.65	1.30
1:F:34:LEU:HD12	1:F:143:THR:CG2	1.57	1.30
1:F:257:PHE:CZ	2:G:366:GLU:CA	2.14	1.30
1:A:385:ASP:OD1	2:B:342:TYR:CD1	1.72	1.30
2:I:335:ALA:CB	2:I:396:ASN:HB2	1.59	1.30
1:H:134:ARG:O	1:H:135:VAL:CG2	1.77	1.30
1:F:256:PRO:CG	2:G:368:PRO:CD	2.01	1.29
1:D:34:LEU:CB	1:D:133:LEU:CA	1.97	1.29
1:D:132:LYS:HG3	1:D:145:THR:N	1.46	1.29
1:D:130:SER:HB2	1:D:147:TYR:CE1	1.67	1.29
1:H:90:GLY:C	2:I:240:PRO:O	1.69	1.29
1:A:256:PRO:CG	2:B:368:PRO:CD	2.09	1.28
2:B:297:LYS:O	2:B:298:LYS:HG2	1.13	1.28
1:D:132:LYS:CG	1:D:144:VAL:O	1.76	1.28
1:A:132:LYS:HB2	1:A:145:THR:CB	1.64	1.28
1:A:132:LYS:CG	1:A:144:VAL:O	1.78	1.28
1:F:256:PRO:CG	2:G:368:PRO:HG3	1.63	1.28
1:F:310:SER:OG	1:F:388:VAL:HG13	1.26	1.28
1:A:385:ASP:OD2	2:B:342:TYR:CD1	1.82	1.27
1:A:291:VAL:CG1	1:D:315:VAL:HG12	1.63	1.27
1:A:291:VAL:HG11	1:D:315:VAL:CG1	1.63	1.27
1:H:257:PHE:CE2	1:H:273:VAL:HG23	1.20	1.27
1:F:256:PRO:CG	2:G:368:PRO:CG	2.13	1.27
1:A:256:PRO:CB	2:B:368:PRO:HG3	1.59	1.27
1:H:310:SER:N	1:H:388:VAL:HG21	1.48	1.27
1:D:34:LEU:CG	1:D:133:LEU:CA	2.11	1.26
1:F:257:PHE:HB3	1:F:273:VAL:N	1.18	1.26
1:H:90:GLY:CA	2:I:240:PRO:O	1.83	1.26
1:H:11:VAL:HG23	1:H:33:LEU:CD1	1.64	1.26
1:D:13:VAL:CG2	1:D:391:PRO:CB	2.12	1.25
1:F:132:LYS:HD3	1:F:143:THR:CG2	1.65	1.25

*Continued on next page...*

*Continued from previous page...*

Atom-1	Atom-2	Interatomic distance (Å)	Clash overlap (Å)
1:A:93:TYR:C	2:B:290:HIS:NE2	1.90	1.25
1:F:257:PHE:CE1	2:G:366:GLU:HA	1.70	1.25
1:D:257:PHE:CE1	1:D:273:VAL:HG21	1.43	1.24
1:H:310:SER:H	1:H:388:VAL:CG2	1.49	1.24
1:A:132:LYS:CG	1:A:144:VAL:C	2.05	1.23
1:D:132:LYS:CB	1:D:145:THR:CA	1.93	1.23
2:E:156:THR:HG23	2:I:88:GLU:CD	1.52	1.23
1:A:93:TYR:O	2:B:290:HIS:CE1	1.90	1.23
1:D:132:LYS:CA	1:D:145:THR:HA	1.68	1.23
1:H:134:ARG:CG	1:H:135:VAL:H	1.47	1.23
2:G:336:ARG:O	2:G:397:ASN:ND2	1.71	1.23
1:H:258:GLY:HA2	2:I:362:ARG:NH1	1.53	1.23
1:H:130:SER:HB2	1:H:147:TYR:CE1	1.74	1.22
1:H:134:ARG:HG3	1:H:135:VAL:N	1.38	1.22
1:A:132:LYS:HG3	1:A:145:THR:N	1.54	1.22
1:F:34:LEU:HD21	1:F:134:ARG:CB	1.69	1.22
1:F:34:LEU:CG	1:F:133:LEU:C	2.07	1.22
1:F:132:LYS:CA	1:F:145:THR:HA	1.70	1.22
2:I:213:LYS:CD	2:I:332:VAL:HG12	1.68	1.22
1:D:132:LYS:CA	1:D:144:VAL:O	1.88	1.21
1:H:133:LEU:O	1:H:144:VAL:N	1.74	1.21
1:A:95:PHE:CA	2:B:290:HIS:CB	2.12	1.21
1:D:34:LEU:HG	1:D:133:LEU:O	1.34	1.21
1:F:11:VAL:HG21	1:F:270:ASN:CG	1.58	1.20
1:A:52:LYS:HE3	2:B:100:ARG:CZ	1.69	1.20
1:H:95:PHE:CA	2:I:290:HIS:HB2	1.70	1.20
1:F:34:LEU:HG	1:F:133:LEU:O	1.35	1.20
1:F:90:GLY:HA3	2:G:240:PRO:O	1.40	1.20
1:H:132:LYS:CD	1:H:145:THR:OG1	1.90	1.20
1:H:170:TRP:CH2	1:H:256:PRO:HD2	1.77	1.20
1:A:257:PHE:CZ	1:A:273:VAL:HG23	1.75	1.19
1:A:34:LEU:HG	1:A:133:LEU:CA	1.72	1.19
1:F:310:SER:OG	1:F:388:VAL:CG1	1.90	1.19
1:F:386:HIS:O	1:F:387:ILE:O	1.60	1.19
1:A:257:PHE:CB	1:A:273:VAL:HB	1.70	1.19
1:A:291:VAL:HG23	1:D:305:ALA:H	1.05	1.18
1:A:256:PRO:CD	2:B:368:PRO:HG3	1.74	1.18
2:I:213:LYS:HB3	2:I:333:PRO:N	1.56	1.18
1:A:257:PHE:CD2	2:B:365:GLY:C	2.16	1.18
1:H:34:LEU:HD11	1:H:143:THR:HG23	1.19	1.18
1:D:13:VAL:HG21	1:D:391:PRO:HB2	1.25	1.17

*Continued on next page...*

*Continued from previous page...*

Atom-1	Atom-2	Interatomic distance (Å)	Clash overlap (Å)
1:H:132:LYS:CB	1:H:145:THR:HA	1.74	1.17
1:H:257:PHE:CE1	1:H:273:VAL:HG21	1.49	1.17
1:F:359:ALA:HB1	2:G:405:GLN:CG	1.73	1.17
1:F:383:PRO:O	1:F:384:LYS:HG2	1.42	1.17
1:A:13:VAL:CG2	1:A:391:PRO:CG	2.09	1.17
1:D:130:SER:HB2	1:D:147:TYR:CD1	1.80	1.17
1:F:256:PRO:CB	2:G:368:PRO:HD3	1.75	1.17
1:H:13:VAL:CG2	1:H:391:PRO:CG	2.23	1.17
1:H:90:GLY:HA3	2:I:240:PRO:O	1.41	1.16
1:H:359:ALA:CB	2:I:405:GLN:HG3	1.75	1.16
2:E:296:HIS:O	2:E:297:LYS:HG2	1.45	1.16
1:A:256:PRO:HA	2:B:368:PRO:CB	1.75	1.16
1:A:257:PHE:CZ	1:A:273:VAL:HG21	1.76	1.16
1:H:132:LYS:HG3	1:H:145:THR:OG1	1.28	1.16
1:H:258:GLY:CA	2:I:362:ARG:NH1	2.07	1.15
1:A:52:LYS:HE3	2:B:100:ARG:NH1	1.58	1.15
1:F:34:LEU:N	1:F:133:LEU:HA	0.83	1.15
1:H:95:PHE:CE1	2:I:289:CYS:HA	1.82	1.15
1:F:129:ALA:O	1:F:147:TYR:HD1	1.28	1.15
1:D:13:VAL:CG2	1:D:391:PRO:HB2	1.74	1.15
1:D:34:LEU:CD1	1:D:143:THR:CG2	2.17	1.15
1:D:95:PHE:CA	2:E:290:HIS:HB2	1.74	1.15
1:F:108:VAL:C	1:F:109:GLU:N	2.00	1.14
2:B:137:HIS:NE2	2:B:293:VAL:HB	1.62	1.14
1:D:256:PRO:HA	2:E:368:PRO:CB	1.73	1.14
1:D:34:LEU:HB2	1:D:133:LEU:N	1.60	1.14
2:G:332:VAL:HB	2:G:333:PRO:HD3	1.26	1.14
1:F:132:LYS:HA	1:F:144:VAL:O	1.34	1.14
1:A:256:PRO:CA	2:B:368:PRO:HB3	1.76	1.14
1:D:52:LYS:HE3	2:E:100:ARG:NH1	1.63	1.14
1:F:257:PHE:HA	1:F:272:ALA:O	1.47	1.14
1:D:13:VAL:HG22	1:D:391:PRO:CB	1.74	1.13
1:D:108:VAL:C	1:D:109:GLU:N	2.01	1.13
1:D:130:SER:CA	1:D:147:TYR:HA	1.78	1.13
1:H:52:LYS:HE3	2:I:100:ARG:NH2	1.61	1.13
1:H:132:LYS:HB2	1:H:145:THR:HG23	1.25	1.13
1:A:34:LEU:HD13	1:A:143:THR:HG23	1.26	1.13
1:D:34:LEU:CG	1:D:133:LEU:HA	1.77	1.12
1:H:257:PHE:CZ	1:H:273:VAL:HG21	1.74	1.12
2:E:336:ARG:HG3	2:E:337:ASN:N	1.63	1.12
1:A:385:ASP:CG	2:B:342:TYR:CE1	2.22	1.12

*Continued on next page...*

*Continued from previous page...*

Atom-1	Atom-2	Interatomic distance (Å)	Clash overlap (Å)
1:F:132:LYS:C	1:F:144:VAL:O	1.87	1.12
1:F:359:ALA:HB1	2:G:405:GLN:HG3	1.17	1.12
1:H:90:GLY:O	2:I:240:PRO:O	1.68	1.12
1:A:289:ARG:HB3	1:D:305:ALA:HB1	1.27	1.11
2:I:340:VAL:CG2	2:I:341:THR:N	1.96	1.11
1:F:95:PHE:HA	2:G:290:HIS:HB2	1.12	1.11
2:E:209:PRO:HG2	2:E:331:ARG:CG	1.80	1.11
1:D:170:TRP:CH2	1:D:256:PRO:CD	2.33	1.11
1:F:95:PHE:CE1	2:G:288:GLN:O	2.04	1.11
1:H:11:VAL:CG2	1:H:33:LEU:HD12	1.80	1.11
1:A:257:PHE:CD2	1:A:273:VAL:CG2	2.26	1.11
1:A:257:PHE:CD1	1:A:273:VAL:HB	1.84	1.11
1:H:257:PHE:CE2	2:I:366:GLU:N	2.18	1.11
1:D:132:LYS:HG2	1:D:144:VAL:O	1.47	1.10
1:D:170:TRP:CZ2	1:D:256:PRO:HD2	1.83	1.10
1:D:132:LYS:CD	1:D:143:THR:HG22	1.81	1.10
1:F:130:SER:HA	1:F:147:TYR:HA	1.28	1.10
1:H:108:VAL:C	1:H:109:GLU:N	2.03	1.10
1:F:256:PRO:CD	2:G:368:PRO:HG3	1.82	1.10
1:F:132:LYS:CD	1:F:143:THR:CG2	2.30	1.10
2:I:213:LYS:HG2	2:I:332:VAL:CG1	1.69	1.10
1:A:256:PRO:HG3	2:B:368:PRO:CD	1.79	1.10
1:A:290:VAL:HG12	1:D:304:PRO:HA	1.12	1.10
1:A:257:PHE:CD2	1:A:273:VAL:HG23	1.85	1.09
1:H:257:PHE:CE1	1:H:273:VAL:CG2	2.16	1.09
2:I:337:ASN:HB2	2:I:397:ASN:CG	1.73	1.09
1:A:256:PRO:CA	2:B:368:PRO:HG3	1.82	1.09
1:F:34:LEU:CD2	1:F:134:ARG:CB	2.28	1.09
2:B:332:VAL:HB	2:B:333:PRO:HD3	1.34	1.09
1:D:34:LEU:HD12	1:D:132:LYS:CD	1.83	1.09
2:E:213:LYS:O	2:E:331:ARG:C	1.91	1.09
2:E:332:VAL:CG1	2:E:333:PRO:CD	2.30	1.09
1:F:171:THR:O	1:F:173:PHE:N	1.85	1.09
2:G:339:THR:HG22	2:G:340:VAL:H	1.00	1.09
1:H:95:PHE:CA	2:I:290:HIS:CB	2.29	1.09
1:H:130:SER:HA	1:H:147:TYR:HA	1.12	1.09
1:A:132:LYS:CA	1:A:145:THR:HA	1.81	1.09
1:D:257:PHE:CE1	1:D:273:VAL:CG2	2.04	1.09
2:E:156:THR:CG2	2:I:88:GLU:OE1	0.79	1.09
2:I:137:HIS:NE2	2:I:293:VAL:HB	1.68	1.09
2:G:332:VAL:HB	2:G:333:PRO:CD	1.81	1.08

*Continued on next page...*



*Continued from previous page...*

Atom-1	Atom-2	Interatomic distance (Å)	Clash overlap (Å)
2:I:335:ALA:HB3	2:I:396:ASN:HB2	1.21	1.08
2:E:213:LYS:HD2	2:E:333:PRO:CD	1.78	1.08
2:G:297:LYS:O	2:G:298:LYS:HG2	1.50	1.08
2:I:334:LYS:CD	2:I:335:ALA:H	1.67	1.08
1:A:132:LYS:HD3	1:A:143:THR:CG2	1.85	1.07
1:H:95:PHE:CD1	2:I:289:CYS:HA	1.90	1.07
2:I:215:LEU:HG	2:I:332:VAL:HG13	1.20	1.07
2:I:213:LYS:CG	2:I:332:VAL:HG11	1.61	1.07
1:H:11:VAL:HG22	1:H:33:LEU:HD13	1.24	1.07
1:A:130:SER:HA	1:A:147:TYR:HA	1.37	1.06
1:A:289:ARG:HB3	1:D:305:ALA:HB3	1.37	1.06
1:D:13:VAL:HG21	1:D:391:PRO:CB	1.77	1.06
1:H:385:ASP:HB2	2:I:342:TYR:HB2	1.29	1.06
1:A:34:LEU:HD12	1:A:143:THR:HG23	1.17	1.06
2:E:236:PRO:HD3	2:E:298:LYS:O	1.54	1.06
1:A:34:LEU:N	1:A:133:LEU:CA	2.19	1.06
1:A:108:VAL:C	1:A:109:GLU:N	2.09	1.06
1:H:13:VAL:HG22	1:H:391:PRO:HG2	1.38	1.06
1:H:258:GLY:CA	2:I:362:ARG:CZ	2.33	1.06
1:A:132:LYS:HD3	1:A:143:THR:HG22	1.31	1.06
1:F:34:LEU:CG	1:F:133:LEU:O	2.03	1.06
2:G:137:HIS:NE2	2:G:293:VAL:HB	1.70	1.06
1:A:170:TRP:CZ2	1:A:256:PRO:CD	2.39	1.06
1:H:13:VAL:HG22	1:H:391:PRO:HG3	1.11	1.06
1:A:254:THR:HG22	2:B:370:TYR:CD2	1.90	1.05
1:H:130:SER:HB2	1:H:147:TYR:CD1	1.89	1.05
1:H:134:ARG:O	1:H:135:VAL:HG23	0.90	1.05
2:I:213:LYS:CB	2:I:333:PRO:N	2.19	1.05
1:F:34:LEU:HD13	1:F:143:THR:HG23	1.35	1.05
1:H:257:PHE:CD2	2:I:365:GLY:O	2.09	1.05
2:I:213:LYS:CG	2:I:332:VAL:HG12	1.63	1.05
1:D:95:PHE:CA	2:E:290:HIS:CB	2.34	1.05
1:D:130:SER:HA	1:D:147:TYR:CA	1.84	1.05
1:F:257:PHE:CA	1:F:272:ALA:O	2.04	1.05
1:A:256:PRO:HG3	2:B:368:PRO:HG2	1.34	1.05
1:D:257:PHE:CZ	1:D:273:VAL:HG21	1.69	1.05
1:H:13:VAL:CG2	1:H:391:PRO:HG3	1.87	1.04
1:H:310:SER:HB2	1:H:390:TYR:CD2	1.87	1.04
2:B:297:LYS:O	2:B:298:LYS:CG	2.06	1.04
1:H:11:VAL:CA	1:H:33:LEU:HD12	1.86	1.04
1:H:257:PHE:HE2	2:I:366:GLU:N	1.53	1.04

*Continued on next page...*

*Continued from previous page...*

Atom-1	Atom-2	Interatomic distance (Å)	Clash overlap (Å)
1:F:132:LYS:CE	1:F:143:THR:HG22	1.88	1.04
1:H:34:LEU:HD11	1:H:143:THR:CG2	1.88	1.04
2:I:236:PRO:HD3	2:I:298:LYS:O	1.54	1.04
1:A:90:GLY:O	2:B:241:ASP:HA	1.58	1.04
1:A:132:LYS:HG2	1:A:144:VAL:O	1.52	1.04
1:D:95:PHE:HB2	2:E:290:HIS:HB3	1.40	1.04
1:H:132:LYS:CE	1:H:145:THR:OG1	2.05	1.04
1:F:13:VAL:HG21	1:F:391:PRO:CG	1.83	1.03
1:F:254:THR:HG22	2:G:370:TYR:CG	1.92	1.03
1:H:130:SER:CA	1:H:147:TYR:HA	1.88	1.03
1:A:385:ASP:OD2	2:B:342:TYR:CE1	2.11	1.03
1:D:11:VAL:HG21	1:D:270:ASN:HB3	1.37	1.03
1:A:291:VAL:HG21	1:D:315:VAL:O	1.57	1.03
1:D:359:ALA:HB1	2:E:405:GLN:HG3	1.38	1.03
1:F:129:ALA:O	1:F:147:TYR:CD1	2.10	1.03
1:F:132:LYS:HA	1:F:145:THR:HA	1.30	1.03
1:H:13:VAL:HG13	1:H:391:PRO:HG2	1.36	1.03
2:E:156:THR:CB	2:I:88:GLU:OE1	2.07	1.02
2:E:209:PRO:CG	2:E:331:ARG:HG3	1.89	1.02
1:F:257:PHE:CB	1:F:272:ALA:O	2.07	1.02
1:H:13:VAL:CG1	1:H:391:PRO:HG2	1.88	1.02
1:H:309:SER:C	1:H:388:VAL:HG21	1.77	1.02
2:I:338:PRO:HD3	2:I:394:TRP:CD1	1.94	1.02
1:D:88:MET:HE1	2:E:237:PRO:HG2	1.40	1.02
1:F:11:VAL:HG21	1:F:270:ASN:HB3	1.11	1.02
2:I:213:LYS:HD3	2:I:332:VAL:HG12	1.40	1.02
2:I:209:PRO:CG	2:I:331:ARG:HG3	1.89	1.02
2:E:156:THR:HG22	2:I:88:GLU:OE1	1.57	1.02
2:I:334:LYS:HD3	2:I:335:ALA:H	1.17	1.02
2:B:137:HIS:NE2	2:B:293:VAL:CG1	2.23	1.01
1:F:217:THR:C	1:F:218:GLN:N	2.14	1.01
1:H:34:LEU:O	1:H:35:SER:HB3	1.58	1.01
1:A:41:THR:O	1:H:125:HIS:NE2	1.93	1.01
1:A:256:PRO:CA	2:B:368:PRO:CG	2.37	1.01
1:D:95:PHE:CE1	2:E:289:CYS:HA	1.95	1.01
1:A:130:SER:HB2	1:A:147:TYR:CD1	1.94	1.01
1:D:130:SER:HA	1:D:147:TYR:HA	1.01	1.01
1:F:90:GLY:CA	2:G:240:PRO:O	2.09	1.01
1:F:254:THR:HG22	2:G:370:TYR:CD2	1.94	1.01
1:H:310:SER:H	1:H:388:VAL:HG22	0.87	1.01
2:I:340:VAL:HG23	2:I:341:THR:N	1.60	1.01

*Continued on next page...*

*Continued from previous page...*

Atom-1	Atom-2	Interatomic distance (Å)	Clash overlap (Å)
1:A:132:LYS:HG2	1:A:133:LEU:H	1.19	1.01
2:E:297:LYS:O	2:E:298:LYS:HG2	1.61	1.01
1:A:256:PRO:N	2:B:368:PRO:HG3	1.75	1.01
1:H:359:ALA:HB1	2:I:405:GLN:CG	1.91	1.01
2:I:338:PRO:HD3	2:I:394:TRP:HD1	1.26	1.01
1:A:125:HIS:NE2	1:H:41:THR:O	1.95	1.00
1:A:256:PRO:CA	2:B:368:PRO:CB	2.38	1.00
1:D:132:LYS:CB	1:D:144:VAL:O	2.10	1.00
1:D:132:LYS:HG2	1:D:133:LEU:H	1.24	1.00
1:A:13:VAL:HG21	1:A:391:PRO:HB2	1.38	1.00
1:A:291:VAL:HG23	1:D:305:ALA:N	1.75	1.00
1:A:257:PHE:CD1	1:A:273:VAL:CB	2.41	1.00
1:F:257:PHE:CB	1:F:273:VAL:N	2.05	1.00
2:I:340:VAL:HG22	2:I:341:THR:N	1.76	1.00
1:F:132:LYS:CD	1:F:143:THR:HG22	1.89	1.00
1:D:88:MET:CE	2:E:237:PRO:HG2	1.92	1.00
1:A:130:SER:CB	1:A:147:TYR:CD1	2.45	0.99
1:A:175:ASN:HD21	1:H:126:THR:HG21	1.27	0.99
1:H:217:THR:C	1:H:218:GLN:N	2.15	0.99
1:A:34:LEU:HD12	1:A:132:LYS:HD3	1.43	0.99
2:B:137:HIS:NE2	2:B:293:VAL:CB	2.24	0.99
1:D:133:LEU:N	1:D:144:VAL:O	1.94	0.99
2:I:209:PRO:HG2	2:I:331:ARG:HG3	1.00	0.99
1:H:52:LYS:HE3	2:I:100:ARG:NH1	1.75	0.99
1:A:126:THR:HG21	1:H:175:ASN:ND2	1.77	0.99
1:D:254:THR:HG22	2:E:370:TYR:CD2	1.96	0.99
1:F:257:PHE:CA	1:F:272:ALA:C	2.28	0.99
1:H:254:THR:HG22	2:I:370:TYR:CE2	1.97	0.99
1:A:257:PHE:CE1	1:A:273:VAL:CG2	2.39	0.99
1:D:130:SER:CB	1:D:147:TYR:CD1	2.44	0.99
1:F:34:LEU:HD21	1:F:134:ARG:HB2	1.02	0.99
2:G:339:THR:HG22	2:G:340:VAL:N	1.75	0.99
1:F:256:PRO:HG3	2:G:368:PRO:HG3	1.12	0.99
1:F:257:PHE:CE2	2:G:366:GLU:N	2.31	0.99
2:G:337:ASN:CG	2:G:338:PRO:CD	2.31	0.99
1:A:170:TRP:CH2	1:A:256:PRO:CD	2.45	0.99
1:H:34:LEU:CD1	1:H:143:THR:HG23	1.92	0.99
1:A:130:SER:HA	1:A:147:TYR:CD1	1.97	0.98
1:F:95:PHE:HA	2:G:290:HIS:CB	1.93	0.98
1:H:92:ALA:O	2:I:290:HIS:NE2	1.96	0.98
1:A:290:VAL:CG1	1:D:304:PRO:HA	1.82	0.98

*Continued on next page...*

*Continued from previous page...*

Atom-1	Atom-2	Interatomic distance (Å)	Clash overlap (Å)
1:A:170:TRP:HH2	1:A:256:PRO:HD2	1.25	0.98
1:H:52:LYS:NZ	2:I:100:ARG:HH12	1.61	0.98
2:G:337:ASN:OD1	2:G:338:PRO:HD3	1.63	0.98
1:A:34:LEU:HG	1:A:133:LEU:HA	1.45	0.98
1:F:132:LYS:HA	1:F:145:THR:CA	1.93	0.98
1:A:95:PHE:CD1	2:B:289:CYS:CA	2.47	0.97
1:F:34:LEU:CA	1:F:133:LEU:HA	1.92	0.97
1:F:34:LEU:HD23	1:F:134:ARG:HB2	1.43	0.97
1:H:13:VAL:CG2	1:H:391:PRO:HG2	1.89	0.97
1:A:13:VAL:CG2	1:A:391:PRO:CB	2.40	0.97
1:A:175:ASN:ND2	1:H:126:THR:HG21	1.79	0.97
1:A:257:PHE:CE2	2:B:365:GLY:C	2.20	0.97
2:I:236:PRO:CB	2:I:237:PRO:N	2.26	0.97
1:A:126:THR:HG21	1:H:175:ASN:HD21	1.27	0.97
2:E:137:HIS:NE2	2:E:293:VAL:HB	1.80	0.97
1:D:254:THR:HG22	2:E:370:TYR:CE2	1.98	0.97
1:D:310:SER:N	1:D:388:VAL:HG21	1.80	0.97
1:D:385:ASP:CG	2:E:342:TYR:CD1	2.38	0.97
2:B:296:HIS:O	2:B:297:LYS:HG3	1.62	0.97
1:H:132:LYS:HB2	1:H:145:THR:CG2	1.95	0.97
2:I:213:LYS:CD	2:I:332:VAL:CG1	2.36	0.97
2:G:339:THR:O	2:G:340:VAL:HB	1.61	0.96
1:A:132:LYS:CB	1:A:145:THR:CA	1.99	0.96
1:H:11:VAL:HG22	1:H:33:LEU:CD1	1.78	0.96
1:H:310:SER:CB	1:H:390:TYR:H	1.78	0.96
2:G:332:VAL:CB	2:G:333:PRO:CD	2.41	0.96
1:D:52:LYS:HE3	2:E:100:ARG:CZ	1.96	0.96
1:A:92:ALA:O	2:B:290:HIS:NE2	1.99	0.96
1:H:310:SER:HB3	1:H:390:TYR:H	1.28	0.96
1:H:13:VAL:HG11	1:H:391:PRO:HB2	1.46	0.96
1:F:132:LYS:HD3	1:F:143:THR:HG23	1.46	0.96
1:D:132:LYS:HA	1:D:144:VAL:O	1.63	0.95
1:H:130:SER:CB	1:H:147:TYR:CD1	2.49	0.95
1:A:95:PHE:CA	2:B:290:HIS:HB3	1.95	0.95
2:E:137:HIS:NE2	2:E:293:VAL:CG1	2.29	0.95
2:G:337:ASN:OD1	2:G:394:TRP:HD1	1.46	0.95
1:D:133:LEU:HG	1:D:134:ARG:N	1.79	0.95
1:D:256:PRO:CA	2:E:368:PRO:CB	2.18	0.95
2:I:331:ARG:O	2:I:332:VAL:HG22	1.66	0.95
1:A:130:SER:CA	1:A:147:TYR:CD1	2.48	0.95
1:H:11:VAL:HG21	1:H:270:ASN:HB3	1.47	0.95

*Continued on next page...*

*Continued from previous page...*

Atom-1	Atom-2	Interatomic distance (Å)	Clash overlap (Å)
1:H:132:LYS:HG2	1:H:133:LEU:H	1.29	0.95
2:I:209:PRO:HG2	2:I:331:ARG:CG	1.96	0.95
2:B:332:VAL:HB	2:B:333:PRO:CD	1.96	0.95
1:D:385:ASP:OD1	2:E:342:TYR:HE1	1.49	0.95
1:H:11:VAL:CG2	1:H:270:ASN:HB3	1.96	0.95
1:A:34:LEU:HD11	1:A:143:THR:HG23	0.98	0.94
1:H:90:GLY:O	2:I:240:PRO:C	2.04	0.94
1:H:310:SER:N	1:H:388:VAL:HG22	1.63	0.94
1:A:130:SER:CB	1:A:147:TYR:CE1	2.50	0.94
2:E:336:ARG:HG3	2:E:337:ASN:H	1.23	0.94
1:F:256:PRO:HA	2:G:368:PRO:HB3	1.48	0.94
1:F:132:LYS:HE2	1:F:143:THR:CG2	1.98	0.94
1:H:130:SER:HA	1:H:147:TYR:CA	1.96	0.94
1:A:291:VAL:CG1	1:D:315:VAL:CG1	2.34	0.94
1:H:93:TYR:O	2:I:290:HIS:CE1	2.21	0.94
1:F:257:PHE:HZ	2:G:366:GLU:CB	1.80	0.94
1:H:95:PHE:HB2	2:I:290:HIS:HB3	1.49	0.94
1:A:133:LEU:HG	1:A:134:ARG:N	1.80	0.94
1:F:310:SER:OG	1:F:388:VAL:CB	2.14	0.94
1:H:11:VAL:HG21	1:H:270:ASN:CB	1.98	0.94
1:A:52:LYS:CE	2:B:100:ARG:NH1	2.31	0.94
1:A:52:LYS:C	1:A:53:THR:N	2.21	0.94
1:A:133:LEU:N	1:A:144:VAL:O	1.99	0.94
1:F:257:PHE:CZ	2:G:366:GLU:N	2.34	0.94
1:H:359:ALA:HB1	2:I:405:GLN:HG3	0.97	0.94
1:F:95:PHE:HD1	2:G:264:LYS:O	1.48	0.94
1:H:93:TYR:C	2:I:290:HIS:NE2	2.21	0.93
1:A:95:PHE:HB2	2:B:290:HIS:HB3	1.50	0.93
1:F:310:SER:HG	1:F:388:VAL:HG22	1.31	0.93
1:H:386:HIS:O	1:H:387:ILE:O	1.87	0.93
1:A:34:LEU:CG	1:A:133:LEU:C	2.37	0.93
2:I:335:ALA:HB2	2:I:396:ASN:HB2	1.47	0.93
1:F:256:PRO:HB3	2:G:368:PRO:HD3	1.50	0.93
1:A:88:MET:CE	2:B:238:ASP:O	2.17	0.93
1:F:95:PHE:CE1	2:G:289:CYS:HA	2.04	0.93
1:F:132:LYS:HA	1:F:144:VAL:C	1.90	0.93
1:A:95:PHE:CE1	2:B:288:GLN:O	2.22	0.93
2:B:137:HIS:CE1	2:B:293:VAL:HG12	2.04	0.93
1:D:34:LEU:HD12	1:D:132:LYS:CG	1.97	0.93
2:I:213:LYS:HG2	2:I:332:VAL:HG11	0.93	0.93
1:A:95:PHE:CE1	2:B:289:CYS:CA	2.52	0.92

*Continued on next page...*

*Continued from previous page...*

Atom-1	Atom-2	Interatomic distance (Å)	Clash overlap (Å)
1:D:310:SER:HB2	1:D:390:TYR:CD2	1.74	0.92
2:I:297:LYS:O	2:I:298:LYS:HG2	1.68	0.92
2:E:213:LYS:HD3	2:E:333:PRO:HD2	1.51	0.92
2:I:340:VAL:HG23	2:I:341:THR:H	0.75	0.92
1:A:13:VAL:HG21	1:A:391:PRO:CB	1.97	0.92
1:D:34:LEU:CA	1:D:133:LEU:HA	1.98	0.92
2:E:209:PRO:HG2	2:E:331:ARG:HG3	0.93	0.92
1:H:11:VAL:HG21	1:H:270:ASN:CG	1.90	0.92
1:H:385:ASP:CB	2:I:342:TYR:HB2	1.94	0.92
2:E:156:THR:HG21	2:I:88:GLU:CD	1.70	0.92
2:E:332:VAL:CG1	2:E:333:PRO:HD3	2.00	0.92
1:F:11:VAL:HG23	1:F:270:ASN:HB3	1.50	0.92
1:H:52:LYS:C	1:H:53:THR:N	2.23	0.92
1:A:289:ARG:CB	1:D:305:ALA:HB1	1.84	0.91
1:D:132:LYS:CB	1:D:145:THR:CB	2.41	0.91
1:D:132:LYS:HD3	1:D:143:THR:HG22	0.94	0.91
1:F:95:PHE:CD1	2:G:264:LYS:C	2.42	0.91
1:D:52:LYS:C	1:D:53:THR:N	2.23	0.91
1:F:170:TRP:HH2	1:F:256:PRO:HD2	1.33	0.91
1:A:257:PHE:CD2	2:B:365:GLY:O	2.22	0.91
1:D:34:LEU:HD12	1:D:132:LYS:HG2	1.51	0.91
1:A:256:PRO:HA	2:B:368:PRO:HB3	0.91	0.91
1:F:310:SER:OG	1:F:388:VAL:HG22	1.70	0.91
1:H:134:ARG:C	1:H:135:VAL:HG23	1.92	0.91
1:H:258:GLY:HA2	2:I:362:ARG:NH2	1.84	0.91
1:A:13:VAL:CG2	1:A:391:PRO:HB2	1.99	0.90
1:A:34:LEU:HD11	1:A:143:THR:CG2	1.81	0.90
1:A:310:SER:HB2	1:A:390:TYR:CD2	1.71	0.90
1:H:258:GLY:C	2:I:362:ARG:HH12	1.74	0.90
2:I:334:LYS:HD3	2:I:335:ALA:N	1.85	0.90
1:A:132:LYS:HG2	1:A:133:LEU:N	1.78	0.90
1:D:385:ASP:CG	2:E:342:TYR:CE1	2.45	0.90
2:E:332:VAL:HG12	2:E:333:PRO:HD2	1.05	0.90
1:F:133:LEU:HG	1:F:134:ARG:N	1.84	0.90
1:H:52:LYS:CE	2:I:100:ARG:NH1	2.35	0.90
1:H:257:PHE:CE2	2:I:365:GLY:C	2.44	0.90
1:D:11:VAL:CG2	1:D:270:ASN:HB3	2.01	0.90
1:F:132:LYS:HG2	1:F:133:LEU:H	1.34	0.90
1:H:95:PHE:CE1	2:I:288:GLN:O	2.24	0.90
2:I:337:ASN:OD1	2:I:338:PRO:HD2	1.72	0.90
1:F:310:SER:OG	1:F:388:VAL:CG2	2.20	0.90

*Continued on next page...*

*Continued from previous page...*

Atom-1	Atom-2	Interatomic distance (Å)	Clash overlap (Å)
1:D:34:LEU:HD12	1:D:132:LYS:HD3	1.51	0.90
1:A:52:LYS:HE3	2:B:100:ARG:NH2	1.87	0.89
1:D:257:PHE:CE2	1:D:273:VAL:CG2	2.08	0.89
2:I:338:PRO:HD2	2:I:400:TYR:OH	1.73	0.89
1:A:256:PRO:HB3	2:B:368:PRO:CG	1.82	0.89
1:F:34:LEU:HG	1:F:133:LEU:CA	2.02	0.89
2:I:213:LYS:HD3	2:I:332:VAL:CG1	1.98	0.89
1:A:95:PHE:CB	2:B:290:HIS:HB3	2.03	0.89
1:F:171:THR:C	1:F:173:PHE:H	1.74	0.89
2:I:213:LYS:O	2:I:331:ARG:C	2.02	0.89
1:D:170:TRP:CZ2	1:D:256:PRO:CD	2.53	0.89
2:E:332:VAL:CG1	2:E:333:PRO:HD2	1.96	0.89
1:F:257:PHE:CZ	2:G:366:GLU:CB	2.55	0.89
2:B:137:HIS:CE1	2:B:293:VAL:CG1	2.56	0.89
2:I:340:VAL:HG11	2:I:349:MET:HG2	1.55	0.89
1:H:259:CYS:N	2:I:362:ARG:HH12	1.71	0.89
1:D:132:LYS:CG	1:D:145:THR:N	2.21	0.89
1:D:385:ASP:OD1	2:E:342:TYR:CE1	2.25	0.88
1:F:132:LYS:HE2	1:F:143:THR:HG22	1.54	0.88
1:A:90:GLY:O	2:B:241:ASP:CA	2.21	0.88
1:D:34:LEU:CD1	1:D:132:LYS:HD3	2.03	0.88
1:D:217:THR:C	1:D:218:GLN:N	2.26	0.88
1:F:34:LEU:CD1	1:F:133:LEU:O	2.20	0.88
2:G:336:ARG:C	2:G:397:ASN:HD21	1.77	0.88
2:I:332:VAL:HG12	2:I:333:PRO:HD2	1.54	0.88
1:D:130:SER:CA	1:D:147:TYR:CD1	2.56	0.88
1:F:310:SER:CB	1:F:388:VAL:HG13	2.03	0.88
1:F:359:ALA:CB	2:G:405:GLN:HG3	2.01	0.88
1:H:52:LYS:HZ2	2:I:100:ARG:HH12	1.17	0.88
1:A:254:THR:HG22	2:B:370:TYR:CE2	2.09	0.88
1:F:132:LYS:CG	1:F:145:THR:OG1	2.21	0.87
1:H:132:LYS:HG3	1:H:145:THR:HG1	1.06	0.87
1:A:13:VAL:HG22	1:A:391:PRO:CB	2.04	0.87
1:D:11:VAL:HG21	1:D:270:ASN:CB	2.03	0.87
1:F:95:PHE:CA	2:G:290:HIS:HB2	2.00	0.87
1:A:95:PHE:HD1	2:B:289:CYS:HA	1.37	0.87
1:H:257:PHE:HE2	2:I:366:GLU:CA	1.53	0.87
1:A:88:MET:HB2	2:B:240:PRO:CD	2.04	0.87
1:H:170:TRP:CZ2	1:H:256:PRO:HD2	2.09	0.87
2:I:236:PRO:HB2	2:I:237:PRO:N	1.88	0.87
1:A:289:ARG:CG	1:D:305:ALA:HB1	2.03	0.87

*Continued on next page...*

*Continued from previous page...*

Atom-1	Atom-2	Interatomic distance (Å)	Clash overlap (Å)
1:D:95:PHE:CB	2:E:290:HIS:HB3	2.05	0.87
1:F:13:VAL:CG2	1:F:391:PRO:HG3	2.03	0.87
1:A:289:ARG:CA	1:D:305:ALA:HB2	2.04	0.87
1:D:132:LYS:C	1:D:144:VAL:O	2.12	0.87
2:I:213:LYS:HB3	2:I:332:VAL:C	1.87	0.87
1:A:132:LYS:CG	1:A:145:THR:CA	2.53	0.87
1:A:132:LYS:CA	1:A:144:VAL:O	2.23	0.86
1:D:95:PHE:HE1	2:E:289:CYS:HA	1.35	0.86
1:A:257:PHE:CD2	1:A:273:VAL:CA	2.57	0.86
1:H:170:TRP:HH2	1:H:256:PRO:HD2	1.38	0.86
1:A:310:SER:O	1:A:390:TYR:CD1	1.93	0.86
1:F:132:LYS:HB2	1:F:145:THR:OG1	1.75	0.86
1:F:383:PRO:C	1:F:384:LYS:HG2	1.96	0.86
2:E:213:LYS:HD2	2:E:333:PRO:HD2	0.86	0.86
1:H:130:SER:CA	1:H:147:TYR:CD1	2.58	0.86
1:F:13:VAL:HG22	1:F:391:PRO:HG3	1.56	0.86
1:A:290:VAL:HG12	1:D:304:PRO:CA	2.04	0.86
1:H:134:ARG:CG	1:H:135:VAL:N	2.13	0.86
1:A:34:LEU:HD21	1:A:134:ARG:HB2	1.58	0.85
1:A:125:HIS:CD2	1:H:125:HIS:N	2.43	0.85
1:D:359:ALA:CB	2:E:405:GLN:HG3	2.04	0.85
1:H:132:LYS:HG3	1:H:145:THR:CB	2.06	0.85
1:H:310:SER:CB	1:H:390:TYR:CD2	2.50	0.85
2:E:296:HIS:C	2:E:297:LYS:HG2	1.97	0.85
1:H:13:VAL:CB	1:H:391:PRO:HG2	2.06	0.85
2:G:337:ASN:OD1	2:G:394:TRP:CD1	2.29	0.85
1:A:257:PHE:CD1	1:A:273:VAL:CG2	2.58	0.85
1:D:132:LYS:HG2	1:D:133:LEU:N	1.89	0.85
1:F:95:PHE:CD1	2:G:289:CYS:HA	2.12	0.85
1:F:34:LEU:HG	1:F:134:ARG:N	1.91	0.85
1:H:257:PHE:HZ	2:I:366:GLU:HA	1.28	0.85
1:H:310:SER:HB3	1:H:390:TYR:N	1.92	0.85
1:F:92:ALA:O	2:G:290:HIS:NE2	2.10	0.85
1:D:13:VAL:HG22	1:D:391:PRO:HG3	1.54	0.84
1:D:52:LYS:HE3	2:E:100:ARG:HH12	1.37	0.84
1:A:93:TYR:C	2:B:290:HIS:CE1	2.44	0.84
1:D:310:SER:CB	1:D:390:TYR:CG	2.52	0.84
1:F:257:PHE:HB3	1:F:272:ALA:CA	2.07	0.84
2:I:137:HIS:NE2	2:I:293:VAL:CB	2.39	0.84
2:G:337:ASN:CG	2:G:338:PRO:HD3	1.95	0.84
1:H:132:LYS:CA	1:H:145:THR:CA	2.13	0.84

*Continued on next page...*



*Continued from previous page...*

Atom-1	Atom-2	Interatomic distance (Å)	Clash overlap (Å)
1:A:94:CYS:C	2:B:290:HIS:CD2	2.50	0.84
1:D:90:GLY:O	2:E:241:ASP:HA	1.78	0.84
2:G:337:ASN:CG	2:G:338:PRO:HD2	1.96	0.84
2:I:236:PRO:HB3	2:I:237:PRO:N	1.90	0.84
1:D:91:GLY:C	2:E:240:PRO:HB2	1.97	0.84
1:F:132:LYS:CB	1:F:145:THR:HA	2.06	0.84
1:H:52:LYS:CE	2:I:100:ARG:NH2	2.41	0.84
1:A:217:THR:C	1:A:218:GLN:N	2.31	0.84
1:F:34:LEU:HD21	1:F:134:ARG:CA	2.08	0.84
1:H:130:SER:HA	1:H:147:TYR:CD1	2.13	0.84
2:E:206:HIS:CE1	2:I:192:PRO:HB3	2.12	0.84
1:A:95:PHE:N	2:B:290:HIS:CB	2.40	0.84
2:E:213:LYS:O	2:E:332:VAL:N	2.10	0.83
2:E:137:HIS:NE2	2:E:293:VAL:CB	2.41	0.83
1:F:170:TRP:CZ2	1:F:256:PRO:HD2	2.13	0.83
1:H:132:LYS:HE3	1:H:145:THR:HG1	1.43	0.83
1:A:257:PHE:CD1	1:A:273:VAL:HG21	2.13	0.83
1:D:34:LEU:CD1	1:D:132:LYS:CD	2.56	0.83
1:H:132:LYS:CB	1:H:145:THR:CA	2.50	0.83
2:I:213:LYS:HB3	2:I:333:PRO:CD	2.09	0.83
1:D:95:PHE:CE1	2:E:288:GLN:O	2.31	0.83
1:A:116:THR:CG2	2:B:327:ASN:HB3	2.09	0.82
1:F:95:PHE:HB2	2:G:290:HIS:HB3	1.61	0.82
1:F:256:PRO:CA	2:G:368:PRO:HB3	2.09	0.82
2:I:335:ALA:HB3	2:I:396:ASN:CB	2.06	0.82
1:A:52:LYS:NZ	2:B:100:ARG:HH12	1.77	0.82
1:H:11:VAL:N	1:H:33:LEU:HD12	1.95	0.82
1:A:88:MET:HB2	2:B:240:PRO:HG2	1.60	0.82
1:D:34:LEU:CB	1:D:133:LEU:N	2.26	0.82
1:F:34:LEU:HD13	1:F:143:THR:CG2	1.97	0.82
2:I:332:VAL:HG12	2:I:333:PRO:CD	2.10	0.82
1:H:52:LYS:CE	2:I:100:ARG:CZ	2.51	0.82
1:H:95:PHE:CB	2:I:290:HIS:HB3	2.09	0.82
1:F:132:LYS:CE	1:F:143:THR:CG2	2.50	0.82
1:D:132:LYS:CB	1:D:145:THR:OG1	2.25	0.81
2:G:332:VAL:HG23	2:G:333:PRO:N	1.95	0.81
2:I:213:LYS:HD3	2:I:333:PRO:HD2	1.60	0.81
1:A:34:LEU:HD12	1:A:132:LYS:CD	2.10	0.81
1:A:289:ARG:HB3	1:D:305:ALA:HB2	0.83	0.81
1:A:385:ASP:OD1	2:B:342:TYR:HE1	1.57	0.81
2:G:338:PRO:HD3	2:G:394:TRP:CD1	2.15	0.81

*Continued on next page...*

*Continued from previous page...*

Atom-1	Atom-2	Interatomic distance (Å)	Clash overlap (Å)
1:H:132:LYS:HA	1:H:145:THR:C	2.00	0.81
1:A:132:LYS:CG	1:A:145:THR:N	2.35	0.81
2:G:339:THR:CG2	2:G:340:VAL:H	1.90	0.81
1:H:13:VAL:HG13	1:H:391:PRO:CG	2.10	0.81
1:H:95:PHE:CA	2:I:290:HIS:HB3	2.09	0.81
1:A:95:PHE:HD1	2:B:290:HIS:H	1.26	0.81
1:A:34:LEU:HD13	1:A:143:THR:CG2	1.91	0.81
1:A:88:MET:HB2	2:B:240:PRO:CG	2.10	0.81
1:A:95:PHE:CZ	2:B:288:GLN:O	2.34	0.81
1:H:257:PHE:CD2	2:I:365:GLY:C	2.54	0.81
2:I:338:PRO:CD	2:I:400:TYR:OH	2.29	0.81
1:F:13:VAL:HG21	1:F:391:PRO:CB	2.10	0.81
1:F:34:LEU:CD1	1:F:143:THR:CB	2.59	0.81
1:H:132:LYS:HG2	1:H:133:LEU:N	1.96	0.81
1:A:130:SER:CA	1:A:147:TYR:HA	2.10	0.80
1:H:52:LYS:NZ	2:I:100:ARG:NH1	2.29	0.80
1:F:132:LYS:HB2	1:F:145:THR:CB	2.11	0.80
1:D:257:PHE:CG	2:E:365:GLY:O	2.15	0.80
1:A:257:PHE:CD2	1:A:273:VAL:HA	2.16	0.80
1:D:132:LYS:CG	1:D:145:THR:CA	2.60	0.80
1:H:254:THR:HG22	2:I:370:TYR:CD2	2.16	0.80
1:A:94:CYS:O	2:B:290:HIS:CD2	2.34	0.80
2:B:334:LYS:HD3	2:B:335:ALA:H	1.46	0.80
1:D:74:PRO:HG3	1:D:213:VAL:O	1.80	0.80
2:E:213:LYS:O	2:E:331:ARG:O	1.98	0.80
1:F:130:SER:CA	1:F:147:TYR:HA	2.11	0.80
1:H:116:THR:HG23	2:I:327:ASN:HB3	1.63	0.80
1:A:52:LYS:CE	2:B:100:ARG:HH12	1.95	0.80
1:F:132:LYS:CE	1:F:145:THR:OG1	2.30	0.80
1:H:13:VAL:CG1	1:H:391:PRO:HB2	2.12	0.80
1:D:34:LEU:HB2	1:D:133:LEU:HA	0.81	0.79
1:D:132:LYS:CB	1:D:145:THR:N	2.44	0.79
2:I:337:ASN:OD1	2:I:338:PRO:CD	2.30	0.79
1:A:93:TYR:CA	2:B:290:HIS:NE2	2.44	0.79
1:A:132:LYS:CB	1:A:144:VAL:O	2.30	0.79
2:E:156:THR:OG1	2:I:88:GLU:OE2	2.00	0.79
1:H:132:LYS:O	1:H:133:LEU:CB	2.30	0.79
1:A:88:MET:HE1	2:B:238:ASP:O	1.81	0.79
1:A:95:PHE:HD1	2:B:290:HIS:N	1.79	0.79
1:D:94:CYS:O	2:E:290:HIS:CD2	2.36	0.79
2:B:237:PRO:HG3	2:B:306:VAL:CG1	2.13	0.79

*Continued on next page...*

*Continued from previous page...*

Atom-1	Atom-2	Interatomic distance (Å)	Clash overlap (Å)
2:E:296:HIS:O	2:E:297:LYS:CG	2.30	0.79
1:F:384:LYS:O	1:F:385:ASP:CB	2.31	0.79
2:I:340:VAL:HG11	2:I:349:MET:CG	2.12	0.79
1:H:257:PHE:HZ	2:I:366:GLU:CA	1.88	0.79
1:A:91:GLY:C	2:B:240:PRO:HB2	2.02	0.78
1:A:170:TRP:HZ2	1:A:256:PRO:HD2	1.45	0.78
1:D:256:PRO:HA	2:E:368:PRO:HB3	0.80	0.78
1:A:34:LEU:CG	1:A:133:LEU:HA	2.12	0.78
2:G:337:ASN:OD1	2:G:338:PRO:CD	2.30	0.78
1:A:132:LYS:CB	1:A:145:THR:CB	2.45	0.78
1:D:129:ALA:O	1:D:147:TYR:HD1	1.66	0.78
1:F:52:LYS:HE3	2:G:100:ARG:NH1	1.98	0.78
1:F:385:ASP:O	1:F:386:HIS:O	2.02	0.78
1:H:129:ALA:O	1:H:147:TYR:HD1	1.67	0.78
1:H:11:VAL:HA	1:H:33:LEU:HD12	1.63	0.78
1:H:132:LYS:O	1:H:133:LEU:HB2	1.82	0.78
1:D:170:TRP:HH2	1:D:256:PRO:HD2	0.97	0.78
1:F:13:VAL:CB	1:F:391:PRO:HG2	2.10	0.78
1:F:257:PHE:CD2	1:F:272:ALA:O	2.37	0.78
2:E:156:THR:HG23	2:I:88:GLU:OE1	0.97	0.78
2:E:88:GLU:OE2	2:G:156:THR:OG1	2.02	0.77
1:H:95:PHE:HA	2:I:290:HIS:HB2	0.81	0.77
1:A:116:THR:HG23	2:B:327:ASN:HB3	1.64	0.77
1:H:310:SER:CB	1:H:390:TYR:N	2.47	0.77
1:A:23:GLY:HA3	1:D:306:CYS:O	1.85	0.77
1:A:95:PHE:N	2:B:290:HIS:HB2	1.98	0.77
1:A:34:LEU:CA	1:A:133:LEU:HA	2.13	0.77
1:D:34:LEU:CG	1:D:133:LEU:O	2.17	0.77
1:D:130:SER:HA	1:D:147:TYR:CD1	2.17	0.77
1:F:34:LEU:HD12	1:F:132:LYS:HD3	1.67	0.77
2:I:340:VAL:HB	2:I:349:MET:HA	1.67	0.77
2:I:340:VAL:CG1	2:I:349:MET:HG2	2.13	0.77
1:D:92:ALA:O	2:E:240:PRO:HB3	1.83	0.77
1:F:11:VAL:CG2	1:F:270:ASN:CB	2.32	0.77
1:H:132:LYS:HG3	1:H:145:THR:CA	2.14	0.77
1:F:132:LYS:HE3	1:F:145:THR:OG1	1.84	0.77
1:F:90:GLY:C	2:G:240:PRO:O	2.22	0.77
1:F:95:PHE:CG	2:G:264:LYS:O	2.35	0.77
1:H:13:VAL:CG1	1:H:391:PRO:CG	2.63	0.77
1:F:132:LYS:CB	1:F:145:THR:OG1	2.33	0.77
1:H:132:LYS:CB	1:H:145:THR:CB	2.64	0.76

*Continued on next page...*

*Continued from previous page...*

Atom-1	Atom-2	Interatomic distance (Å)	Clash overlap (Å)
1:F:257:PHE:HZ	2:G:366:GLU:HB2	1.50	0.76
1:D:34:LEU:CD2	1:D:133:LEU:C	2.54	0.76
2:E:297:LYS:O	2:E:298:LYS:CG	2.33	0.76
1:F:256:PRO:CB	2:G:368:PRO:CD	2.52	0.76
1:D:94:CYS:C	2:E:290:HIS:CD2	2.59	0.76
2:E:137:HIS:CE1	2:E:293:VAL:HG12	2.20	0.76
1:F:34:LEU:HD11	1:F:143:THR:CB	2.15	0.76
1:A:126:THR:HG21	1:H:175:ASN:CG	2.06	0.76
1:F:132:LYS:HG3	1:F:144:VAL:C	2.05	0.76
1:H:132:LYS:CG	1:H:145:THR:CB	2.62	0.76
1:F:170:TRP:CH2	1:F:256:PRO:CD	2.59	0.76
1:H:11:VAL:HG23	1:H:33:LEU:HD13	1.36	0.76
1:A:94:CYS:C	2:B:290:HIS:CG	2.58	0.76
1:D:52:LYS:CE	2:E:100:ARG:NH1	2.46	0.76
2:I:297:LYS:O	2:I:298:LYS:CG	2.33	0.76
1:A:52:LYS:HE3	2:B:100:ARG:HH12	1.51	0.75
1:A:125:HIS:N	1:H:125:HIS:CD2	2.44	0.75
2:B:336:ARG:HG3	2:B:337:ASN:N	2.01	0.75
1:A:129:ALA:O	1:A:147:TYR:HD1	1.68	0.75
1:F:359:ALA:HB1	2:G:405:GLN:CD	2.06	0.75
1:A:34:LEU:HD12	1:A:143:THR:CG2	1.88	0.75
1:H:90:GLY:O	2:I:241:ASP:HA	1.87	0.75
1:H:95:PHE:HD1	2:I:290:HIS:H	1.34	0.75
2:B:332:VAL:CB	2:B:333:PRO:CD	2.63	0.75
1:F:129:ALA:C	1:F:147:TYR:HD1	1.90	0.75
2:I:331:ARG:O	2:I:332:VAL:CG2	2.35	0.75
2:I:339:THR:HG22	2:I:340:VAL:H	1.52	0.75
1:F:257:PHE:CE2	2:G:365:GLY:C	2.59	0.75
1:H:384:LYS:O	1:H:385:ASP:CB	2.35	0.75
1:A:95:PHE:HA	2:B:290:HIS:HB2	0.77	0.74
1:A:175:ASN:CG	1:H:126:THR:HG21	2.07	0.74
2:I:213:LYS:CD	2:I:333:PRO:HD2	2.16	0.74
1:D:52:LYS:CE	2:E:100:ARG:HH12	2.00	0.74
1:D:92:ALA:O	2:E:290:HIS:NE2	2.21	0.74
2:B:137:HIS:NE2	2:B:293:VAL:HG11	2.00	0.74
2:E:331:ARG:O	2:E:332:VAL:HG22	1.88	0.74
1:A:34:LEU:HG	1:A:133:LEU:O	1.87	0.74
1:D:95:PHE:HA	2:E:290:HIS:HB2	0.79	0.74
1:D:310:SER:H	1:D:388:VAL:CG2	2.01	0.74
1:H:11:VAL:CB	1:H:33:LEU:HD12	2.18	0.74
1:H:132:LYS:CE	1:H:145:THR:HG1	1.92	0.74

*Continued on next page...*

*Continued from previous page...*

Atom-1	Atom-2	Interatomic distance (Å)	Clash overlap (Å)
1:D:34:LEU:HB2	1:D:132:LYS:C	2.06	0.74
2:I:339:THR:C	2:I:340:VAL:HG12	2.08	0.74
1:A:95:PHE:HE1	2:B:289:CYS:SG	2.11	0.74
1:A:41:THR:CB	1:H:125:HIS:CE1	2.20	0.73
1:A:125:HIS:CD2	1:H:125:HIS:CA	2.52	0.73
1:A:170:TRP:HZ2	1:A:256:PRO:CD	1.97	0.73
1:H:257:PHE:HZ	2:I:366:GLU:CG	2.01	0.73
2:E:296:HIS:C	2:E:297:LYS:CG	2.56	0.73
1:H:34:LEU:HD21	1:H:134:ARG:CB	2.18	0.73
1:H:134:ARG:HA	1:H:142:ILE:O	1.87	0.73
1:A:32:GLU:C	1:A:133:LEU:HD12	2.09	0.73
1:D:130:SER:CB	1:D:147:TYR:CE1	2.59	0.73
2:I:213:LYS:H	2:I:332:VAL:C	1.91	0.73
1:H:134:ARG:HA	1:H:143:THR:HA	1.69	0.73
1:H:257:PHE:CE2	2:I:365:GLY:O	2.41	0.73
2:I:213:LYS:CB	2:I:332:VAL:C	2.51	0.73
1:A:91:GLY:O	2:B:240:PRO:HB2	1.88	0.73
1:D:95:PHE:HD1	2:E:290:HIS:N	1.86	0.73
1:H:34:LEU:HD21	1:H:134:ARG:CA	2.06	0.73
1:D:254:THR:HA	2:E:370:TYR:CD1	2.24	0.73
1:A:130:SER:CA	1:A:147:TYR:HD1	2.02	0.73
1:F:130:SER:HB2	1:F:147:TYR:CE1	2.24	0.73
2:I:137:HIS:NE2	2:I:293:VAL:CG1	2.51	0.73
1:A:52:LYS:HG3	2:B:100:ARG:NH2	2.04	0.73
1:D:129:ALA:O	1:D:147:TYR:CD1	2.40	0.73
1:D:132:LYS:HG3	1:D:144:VAL:CA	2.18	0.73
1:H:34:LEU:O	1:H:35:SER:CB	2.35	0.73
1:A:132:LYS:HB2	1:A:145:THR:CG2	2.18	0.72
1:A:258:GLY:HA2	2:B:362:ARG:CZ	2.19	0.72
1:D:32:GLU:C	1:D:133:LEU:HD12	2.09	0.72
1:F:52:LYS:HE3	2:G:100:ARG:CZ	2.19	0.72
1:F:132:LYS:HD3	1:F:143:THR:HG21	1.70	0.72
1:A:256:PRO:HB3	2:B:368:PRO:HD3	0.76	0.72
1:D:52:LYS:HG3	2:E:100:ARG:NH2	2.04	0.72
1:D:218:GLN:HE22	2:G:336:ARG:NH2	1.87	0.72
1:F:52:LYS:C	1:F:53:THR:N	2.43	0.72
2:G:297:LYS:O	2:G:298:LYS:CG	2.35	0.72
1:H:132:LYS:HB2	1:H:145:THR:CB	2.18	0.72
2:I:337:ASN:CA	2:I:397:ASN:ND2	2.52	0.72
2:I:213:LYS:O	2:I:331:ARG:O	2.07	0.72
2:I:236:PRO:C	2:I:237:PRO:HA	2.09	0.72

*Continued on next page...*

*Continued from previous page...*

Atom-1	Atom-2	Interatomic distance (Å)	Clash overlap (Å)
1:H:116:THR:CG2	2:I:327:ASN:HB3	2.19	0.72
1:H:257:PHE:CZ	2:I:366:GLU:C	2.63	0.72
1:H:88:MET:HE1	2:I:237:PRO:HG2	1.71	0.72
1:H:95:PHE:HD1	2:I:290:HIS:N	1.88	0.72
2:I:338:PRO:CD	2:I:394:TRP:CD1	2.72	0.72
1:D:132:LYS:HB2	1:D:145:THR:OG1	1.89	0.71
2:E:213:LYS:CD	2:E:333:PRO:CD	2.36	0.71
1:F:272:ALA:O	2:G:364:MET:O	2.07	0.71
1:F:171:THR:C	1:F:173:PHE:N	2.38	0.71
1:D:129:ALA:C	1:D:147:TYR:HD1	1.93	0.71
1:H:134:ARG:O	1:H:135:VAL:CB	2.38	0.71
1:A:170:TRP:CZ2	1:A:256:PRO:CG	2.72	0.71
1:A:310:SER:N	1:A:388:VAL:HG21	2.06	0.71
1:F:132:LYS:CG	1:F:144:VAL:C	2.59	0.71
1:F:256:PRO:HG2	2:G:368:PRO:HD3	1.69	0.71
1:A:291:VAL:HG11	1:D:315:VAL:HG12	0.79	0.71
1:F:132:LYS:HG3	1:F:145:THR:OG1	1.90	0.71
1:F:133:LEU:N	1:F:144:VAL:O	2.22	0.71
1:A:125:HIS:CE1	1:H:41:THR:CB	2.22	0.71
1:F:95:PHE:CA	2:G:290:HIS:CB	2.66	0.71
1:A:256:PRO:HB3	2:B:368:PRO:N	2.04	0.70
1:F:34:LEU:CD2	1:F:134:ARG:CA	2.67	0.70
1:A:175:ASN:OD1	1:H:126:THR:HG21	1.91	0.70
1:A:257:PHE:CG	1:A:273:VAL:CG1	2.74	0.70
2:E:330:CYS:O	2:E:331:ARG:O	2.09	0.70
1:F:132:LYS:HE2	1:F:143:THR:HG21	1.72	0.70
1:D:310:SER:N	1:D:388:VAL:CG2	2.53	0.70
2:E:236:PRO:CB	2:E:237:PRO:N	2.55	0.70
1:F:256:PRO:HB3	2:G:368:PRO:CD	2.17	0.70
2:G:339:THR:CG2	2:G:340:VAL:N	2.51	0.70
1:D:132:LYS:HB2	1:D:145:THR:HA	0.73	0.70
1:H:258:GLY:C	2:I:362:ARG:NH1	2.39	0.70
2:I:213:LYS:HB2	2:I:333:PRO:N	2.05	0.70
2:I:334:LYS:CE	2:I:335:ALA:H	2.03	0.70
1:A:130:SER:HB2	1:A:147:TYR:HE1	1.49	0.70
1:H:129:ALA:O	1:H:147:TYR:CD1	2.44	0.70
1:H:88:MET:CE	2:I:237:PRO:HG2	2.21	0.70
1:F:384:LYS:O	1:F:385:ASP:CG	2.30	0.70
1:H:95:PHE:HE1	2:I:289:CYS:HA	1.50	0.70
1:F:132:LYS:CG	1:F:144:VAL:O	2.40	0.70
1:A:126:THR:HG21	1:H:175:ASN:OD1	1.91	0.70

*Continued on next page...*

*Continued from previous page...*

Atom-1	Atom-2	Interatomic distance (Å)	Clash overlap (Å)
2:E:236:PRO:HB2	2:E:237:PRO:N	2.07	0.70
1:H:384:LYS:O	1:H:385:ASP:CG	2.30	0.69
1:D:310:SER:H	1:D:388:VAL:HG21	1.57	0.69
1:F:13:VAL:HG22	1:F:391:PRO:HG2	0.69	0.69
2:E:206:HIS:ND1	2:I:192:PRO:HB3	2.07	0.69
1:A:92:ALA:O	2:B:290:HIS:CD2	2.46	0.69
1:H:34:LEU:CD2	1:H:134:ARG:HB3	2.22	0.69
1:A:132:LYS:HG3	1:A:145:THR:CA	2.22	0.69
1:A:171:THR:OG1	1:A:172:PRO:HD2	1.92	0.69
1:A:289:ARG:C	1:D:305:ALA:HB2	2.13	0.69
1:D:32:GLU:O	1:D:133:LEU:HD12	1.93	0.69
1:H:130:SER:CB	1:H:147:TYR:CE1	2.63	0.69
1:D:170:TRP:CZ2	1:D:256:PRO:HG2	2.28	0.69
1:F:359:ALA:HB2	2:G:405:GLN:OE1	1.93	0.69
1:F:33:LEU:HD22	1:F:36:VAL:HG23	1.73	0.69
1:A:34:LEU:CB	1:A:133:LEU:HA	2.23	0.68
1:A:129:ALA:O	1:A:147:TYR:CD1	2.46	0.68
1:H:88:MET:HB2	2:I:240:PRO:HG2	1.74	0.68
1:H:132:LYS:HG3	1:H:145:THR:N	2.07	0.68
1:D:90:GLY:O	2:E:241:ASP:CA	2.37	0.68
2:I:337:ASN:HB2	2:I:397:ASN:CB	2.23	0.68
1:F:257:PHE:HD2	1:F:272:ALA:O	1.76	0.68
1:F:359:ALA:CB	2:G:405:GLN:OE1	2.42	0.68
2:B:236:PRO:HD3	2:B:298:LYS:O	1.93	0.68
1:D:13:VAL:CG2	1:D:391:PRO:HG3	2.16	0.68
1:F:384:LYS:O	1:F:385:ASP:HB3	1.93	0.68
1:H:94:CYS:C	2:I:290:HIS:CD2	2.67	0.68
1:D:52:LYS:HE3	2:E:100:ARG:NH2	2.09	0.68
1:F:132:LYS:HG2	1:F:133:LEU:N	2.08	0.68
1:F:132:LYS:CB	1:F:145:THR:CA	2.72	0.68
1:H:132:LYS:CG	1:H:145:THR:CA	2.72	0.68
1:A:132:LYS:CD	1:A:143:THR:HG22	2.16	0.68
1:D:132:LYS:HD3	1:D:143:THR:HG23	1.70	0.68
2:G:334:LYS:CG	2:G:335:ALA:H	2.07	0.68
1:H:132:LYS:CB	1:H:145:THR:OG1	2.42	0.68
1:A:32:GLU:O	1:A:133:LEU:HD12	1.94	0.68
2:I:331:ARG:C	2:I:332:VAL:CG2	2.62	0.68
1:F:130:SER:HA	1:F:147:TYR:CA	2.16	0.68
1:D:129:ALA:O	1:D:147:TYR:HB3	1.94	0.67
1:D:385:ASP:CB	2:E:342:TYR:HD1	2.07	0.67
1:F:132:LYS:N	1:F:145:THR:HA	2.09	0.67

*Continued on next page...*

*Continued from previous page...*

Atom-1	Atom-2	Interatomic distance (Å)	Clash overlap (Å)
1:H:94:CYS:O	2:I:290:HIS:CD2	2.47	0.67
1:A:383:PRO:O	1:A:384:LYS:C	2.32	0.67
1:D:132:LYS:CA	1:D:145:THR:CA	2.56	0.67
1:F:11:VAL:HG11	1:F:270:ASN:ND2	2.08	0.67
1:A:291:VAL:HG21	1:D:315:VAL:C	2.15	0.67
1:D:170:TRP:HH2	1:D:256:PRO:CD	1.86	0.67
1:D:11:VAL:HG21	1:D:270:ASN:CG	2.15	0.67
1:A:256:PRO:CB	2:B:368:PRO:CB	2.65	0.67
1:F:95:PHE:CE1	2:G:264:LYS:O	2.41	0.67
2:G:203:GLU:HB2	2:G:333:PRO:HG2	1.75	0.67
1:D:95:PHE:CB	2:E:290:HIS:CB	2.71	0.67
1:D:95:PHE:HD1	2:E:290:HIS:H	1.42	0.67
1:D:258:GLY:HA2	2:E:362:ARG:CZ	2.24	0.67
1:A:359:ALA:HB1	2:B:405:GLN:HG3	1.75	0.66
1:D:130:SER:HA	1:D:147:TYR:CG	2.30	0.66
1:D:383:PRO:O	1:D:384:LYS:C	2.33	0.66
1:H:34:LEU:HD21	1:H:134:ARG:HB3	1.78	0.66
1:H:134:ARG:CA	1:H:142:ILE:O	2.43	0.66
1:A:34:LEU:CG	1:A:133:LEU:CA	2.63	0.66
1:F:34:LEU:HD12	1:F:143:THR:HG23	0.67	0.66
1:A:94:CYS:N	2:B:290:HIS:CD2	2.64	0.66
1:D:132:LYS:HB2	1:D:145:THR:CG2	2.26	0.66
1:F:90:GLY:O	2:G:240:PRO:O	2.12	0.66
1:H:253:HIS:O	2:I:370:TYR:CE1	2.49	0.66
1:A:88:MET:CB	2:B:240:PRO:CD	2.73	0.66
2:G:202:ARG:NE	2:G:396:ASN:OD1	2.28	0.66
2:I:137:HIS:CE1	2:I:293:VAL:CG1	2.79	0.66
1:A:170:TRP:HZ3	1:A:259:CYS:SG	2.18	0.66
1:H:258:GLY:CA	2:I:362:ARG:NH2	2.54	0.66
1:A:132:LYS:C	1:A:144:VAL:O	2.34	0.66
2:I:137:HIS:CE1	2:I:293:VAL:HG12	2.31	0.66
1:A:170:TRP:CZ2	1:A:256:PRO:HG2	2.31	0.66
1:F:52:LYS:HE3	2:G:100:ARG:NH2	2.11	0.66
2:G:332:VAL:CG2	2:G:333:PRO:CD	2.74	0.66
1:A:131:ALA:N	1:A:147:TYR:HA	2.10	0.65
1:A:291:VAL:CB	1:D:315:VAL:HG12	2.26	0.65
1:H:386:HIS:O	1:H:387:ILE:C	2.34	0.65
1:D:132:LYS:CD	1:D:143:THR:CG2	2.51	0.65
1:H:257:PHE:HZ	2:I:366:GLU:HG3	1.60	0.65
2:G:137:HIS:NE2	2:G:293:VAL:CB	2.55	0.65
2:G:338:PRO:HD3	2:G:394:TRP:HD1	1.60	0.65

*Continued on next page...*



*Continued from previous page...*

Atom-1	Atom-2	Interatomic distance (Å)	Clash overlap (Å)
1:A:257:PHE:CG	1:A:273:VAL:CG2	2.54	0.65
1:F:383:PRO:O	1:F:384:LYS:CG	2.34	0.65
1:H:171:THR:C	1:H:173:PHE:H	1.99	0.65
1:A:291:VAL:CG2	1:D:315:VAL:O	2.41	0.65
1:H:92:ALA:O	2:I:290:HIS:CD2	2.49	0.65
1:H:95:PHE:CZ	2:I:288:GLN:O	2.49	0.65
1:H:254:THR:HA	2:I:370:TYR:CG	2.31	0.65
2:E:137:HIS:NE2	2:E:293:VAL:HG11	2.12	0.65
1:F:93:TYR:C	2:G:290:HIS:NE2	2.50	0.65
1:F:116:THR:CG2	2:G:327:ASN:HB3	2.27	0.65
1:A:23:GLY:O	1:D:305:ALA:HA	1.97	0.65
1:D:88:MET:HE3	2:E:237:PRO:HG2	1.74	0.65
1:F:92:ALA:O	2:G:290:HIS:CD2	2.50	0.65
2:I:213:LYS:HD2	2:I:333:PRO:O	1.97	0.65
1:D:359:ALA:HB1	2:E:405:GLN:CG	2.21	0.65
1:F:34:LEU:HD11	1:F:143:THR:HA	1.78	0.65
2:B:295:ASN:O	2:B:297:LYS:N	2.30	0.64
1:D:170:TRP:CZ2	1:D:256:PRO:CG	2.80	0.64
1:H:13:VAL:CG1	1:H:391:PRO:CB	2.74	0.64
2:I:297:LYS:O	2:I:298:LYS:CB	2.44	0.64
1:A:34:LEU:CD2	1:A:134:ARG:HB2	2.25	0.64
1:F:132:LYS:CD	1:F:145:THR:OG1	2.46	0.64
2:E:215:LEU:HG	2:E:332:VAL:HG13	1.79	0.64
2:E:236:PRO:CD	2:E:298:LYS:O	2.39	0.64
2:B:297:LYS:C	2:B:298:LYS:HG2	2.12	0.64
1:F:88:MET:HB2	2:G:240:PRO:HG2	1.80	0.64
1:F:93:TYR:O	2:G:290:HIS:CE1	2.50	0.64
1:H:35:SER:HA	1:H:270:ASN:OD1	1.98	0.64
1:H:257:PHE:CZ	2:I:366:GLU:O	2.50	0.64
2:E:88:GLU:CD	2:G:156:THR:OG1	2.33	0.64
1:F:132:LYS:HB2	1:F:145:THR:HG1	1.60	0.64
1:H:52:LYS:CE	2:I:100:ARG:HH12	2.07	0.64
2:I:295:ASN:O	2:I:297:LYS:N	2.30	0.64
1:D:385:ASP:CG	2:E:342:TYR:HD1	1.94	0.64
2:I:213:LYS:HB2	2:I:333:PRO:O	1.98	0.64
1:H:171:THR:O	1:H:173:PHE:N	2.30	0.64
2:I:337:ASN:CG	2:I:338:PRO:CD	2.61	0.64
1:A:130:SER:HA	1:A:147:TYR:CA	2.19	0.64
2:B:203:GLU:CD	2:B:333:PRO:HG2	2.18	0.64
2:E:192:PRO:HB3	2:G:206:HIS:CE1	2.32	0.64
1:F:132:LYS:HA	1:F:145:THR:N	2.12	0.64

*Continued on next page...*

*Continued from previous page...*

Atom-1	Atom-2	Interatomic distance (Å)	Clash overlap (Å)
1:F:386:HIS:O	1:F:387:ILE:C	2.35	0.64
1:A:257:PHE:CD1	1:A:273:VAL:CG1	2.80	0.63
1:D:34:LEU:CG	1:D:133:LEU:N	2.59	0.63
1:D:310:SER:HB2	1:D:390:TYR:CG	2.09	0.63
2:E:295:ASN:O	2:E:297:LYS:N	2.31	0.63
1:H:129:ALA:C	1:H:147:TYR:HD1	2.02	0.63
2:I:337:ASN:CB	2:I:397:ASN:CG	2.59	0.63
1:F:34:LEU:HD23	1:F:134:ARG:CB	2.10	0.63
1:F:95:PHE:HE1	2:G:289:CYS:HA	1.58	0.63
1:H:359:ALA:CA	2:I:405:GLN:HG3	2.28	0.63
1:F:133:LEU:HG	1:F:134:ARG:H	1.63	0.63
2:I:215:LEU:N	2:I:332:VAL:HG22	2.13	0.63
1:A:94:CYS:N	2:B:290:HIS:NE2	2.45	0.63
1:F:132:LYS:HB2	1:F:145:THR:HA	1.81	0.63
2:G:339:THR:O	2:G:340:VAL:CB	2.39	0.63
1:A:88:MET:HE2	2:B:238:ASP:O	1.97	0.63
1:A:92:ALA:O	2:B:240:PRO:HB3	1.99	0.63
1:A:257:PHE:CG	2:B:365:GLY:O	2.51	0.63
1:D:385:ASP:HB2	2:E:342:TYR:HD1	1.63	0.63
1:F:132:LYS:CB	1:F:144:VAL:O	2.47	0.63
1:H:131:ALA:N	1:H:147:TYR:HA	2.14	0.63
1:D:93:TYR:C	2:E:290:HIS:NE2	2.52	0.63
1:D:95:PHE:CD1	2:E:289:CYS:HA	2.33	0.63
2:G:295:ASN:O	2:G:297:LYS:N	2.30	0.63
2:G:332:VAL:HB	2:G:333:PRO:HD2	1.75	0.63
1:H:311:ASP:HB3	1:H:390:TYR:CD2	2.34	0.63
1:H:384:LYS:O	1:H:385:ASP:HB3	1.99	0.63
1:F:132:LYS:HG3	1:F:145:THR:N	2.13	0.62
1:F:256:PRO:N	2:G:368:PRO:HG3	2.14	0.62
1:A:257:PHE:CB	1:A:273:VAL:CB	2.51	0.62
1:D:34:LEU:H	1:D:133:LEU:HB2	1.63	0.62
2:G:332:VAL:HG23	2:G:333:PRO:CD	2.29	0.62
2:E:89:GLY:O	2:G:207:SER:HB2	1.98	0.62
1:F:359:ALA:CB	2:G:405:GLN:CD	2.67	0.62
2:I:332:VAL:CG1	2:I:333:PRO:CD	2.77	0.62
1:A:130:SER:HA	1:A:147:TYR:CG	2.34	0.62
1:A:132:LYS:HA	1:A:144:VAL:O	1.98	0.62
1:A:309:SER:CB	1:A:390:TYR:OH	2.46	0.62
2:E:137:HIS:CE1	2:E:293:VAL:CG1	2.81	0.62
1:A:291:VAL:CG1	1:D:315:VAL:HG11	2.29	0.62
1:D:95:PHE:CZ	2:E:288:GLN:O	2.53	0.62

*Continued on next page...*

*Continued from previous page...*

Atom-1	Atom-2	Interatomic distance (Å)	Clash overlap (Å)
1:F:95:PHE:CZ	2:G:288:GLN:O	2.50	0.62
1:H:132:LYS:HA	1:H:146:ALA:N	2.14	0.61
1:A:34:LEU:N	1:A:133:LEU:CB	2.64	0.61
1:D:13:VAL:CG1	1:D:391:PRO:HB2	2.30	0.61
1:H:90:GLY:C	2:I:240:PRO:C	2.52	0.61
1:H:133:LEU:C	1:H:144:VAL:H	1.93	0.61
1:F:34:LEU:HD11	1:F:143:THR:OG1	2.00	0.61
1:F:52:LYS:HE3	2:G:100:ARG:HH12	1.66	0.61
1:H:11:VAL:HG23	1:H:270:ASN:HB3	1.79	0.61
1:A:291:VAL:CB	1:D:315:VAL:CG1	2.79	0.61
1:H:91:GLY:C	2:I:240:PRO:HB2	2.21	0.61
1:F:256:PRO:HD3	2:G:368:PRO:HG3	1.78	0.61
2:I:295:ASN:C	2:I:297:LYS:H	2.05	0.61
1:D:310:SER:CB	1:D:390:TYR:CD2	2.59	0.61
2:E:213:LYS:HD3	2:E:333:PRO:CD	2.17	0.61
2:G:332:VAL:CB	2:G:333:PRO:HD3	1.96	0.61
1:H:90:GLY:O	2:I:241:ASP:CA	2.48	0.61
1:F:257:PHE:CZ	2:G:366:GLU:HB2	2.31	0.60
1:F:257:PHE:CD2	2:G:365:GLY:C	2.74	0.60
1:D:254:THR:CG2	2:E:370:TYR:CD2	2.79	0.60
1:H:130:SER:HA	1:H:147:TYR:CG	2.35	0.60
1:A:126:THR:CG2	1:H:175:ASN:HD21	2.09	0.60
2:B:236:PRO:CD	2:B:298:LYS:O	2.49	0.60
1:F:132:LYS:O	1:F:133:LEU:CB	2.49	0.60
1:A:74:PRO:HG3	1:A:213:VAL:O	2.01	0.60
1:A:88:MET:CB	2:B:240:PRO:HD2	2.31	0.60
1:D:130:SER:C	1:D:147:TYR:HA	2.21	0.60
1:F:170:TRP:CZ2	1:F:256:PRO:CD	2.83	0.60
1:H:132:LYS:CE	1:H:143:THR:HG22	2.32	0.60
1:A:34:LEU:CD1	1:A:132:LYS:HD3	2.23	0.60
1:A:88:MET:HB2	2:B:240:PRO:HD2	1.84	0.60
1:D:130:SER:HA	1:D:147:TYR:CB	2.31	0.60
1:H:130:SER:CA	1:H:147:TYR:HD1	2.15	0.60
1:D:34:LEU:N	1:D:133:LEU:HA	2.16	0.60
1:F:32:GLU:O	1:F:133:LEU:HD12	2.01	0.60
1:D:34:LEU:CD2	1:D:134:ARG:N	2.65	0.60
1:D:218:GLN:NE2	2:G:336:ARG:NH1	2.50	0.60
2:G:334:LYS:HG2	2:G:335:ALA:H	1.64	0.60
1:H:34:LEU:CD1	1:H:143:THR:CG2	2.64	0.60
1:A:90:GLY:O	2:B:241:ASP:N	2.22	0.59
1:F:257:PHE:CG	1:F:272:ALA:O	2.54	0.59

*Continued on next page...*

*Continued from previous page...*

Atom-1	Atom-2	Interatomic distance (Å)	Clash overlap (Å)
1:H:88:MET:HB2	2:I:240:PRO:CG	2.32	0.59
2:I:332:VAL:CG1	2:I:333:PRO:HD2	2.30	0.59
1:F:34:LEU:CD2	1:F:134:ARG:N	2.66	0.59
2:G:337:ASN:ND2	2:G:338:PRO:HD2	2.16	0.59
2:I:337:ASN:HB2	2:I:397:ASN:ND2	2.17	0.59
1:A:34:LEU:HD11	1:A:143:THR:CB	2.31	0.59
2:I:215:LEU:CG	2:I:332:VAL:HG13	2.14	0.59
1:F:257:PHE:HA	2:G:364:MET:O	2.03	0.59
1:A:291:VAL:HG13	1:D:317:ILE:HG13	1.84	0.59
1:H:11:VAL:HG23	1:H:33:LEU:HD12	1.52	0.59
1:H:385:ASP:CB	2:I:342:TYR:CB	2.74	0.59
1:A:9:ASN:ND2	1:A:271:CYS:O	2.35	0.59
1:D:116:THR:CG2	2:E:327:ASN:HB3	2.32	0.59
1:H:88:MET:HB2	2:I:240:PRO:CD	2.32	0.59
2:G:297:LYS:C	2:G:298:LYS:HG2	2.22	0.59
1:A:41:THR:CG2	1:H:125:HIS:HE1	2.10	0.59
1:F:359:ALA:CB	2:G:405:GLN:CG	2.65	0.59
2:I:337:ASN:HA	2:I:397:ASN:ND2	2.17	0.59
1:A:175:ASN:HD21	1:H:126:THR:CG2	2.10	0.59
1:D:34:LEU:HD23	1:D:134:ARG:N	2.18	0.59
1:F:34:LEU:N	1:F:133:LEU:CB	2.63	0.59
1:H:132:LYS:HA	1:H:145:THR:HA	0.60	0.59
1:H:134:ARG:HG3	1:H:135:VAL:H	0.56	0.59
1:A:256:PRO:HB3	2:B:368:PRO:CB	2.31	0.58
1:A:257:PHE:CD1	1:A:273:VAL:HG11	2.39	0.58
1:D:254:THR:HG22	2:E:370:TYR:CG	2.38	0.58
1:F:310:SER:N	1:F:388:VAL:HG22	2.17	0.58
1:H:36:VAL:HG12	1:H:37:THR:N	2.17	0.58
1:H:52:LYS:CE	2:I:100:ARG:HH22	2.14	0.58
1:D:254:THR:HG22	2:E:370:TYR:CZ	2.37	0.58
1:H:253:HIS:O	2:I:370:TYR:CD1	2.56	0.58
2:I:237:PRO:HG3	2:I:306:VAL:HG13	1.85	0.58
1:A:132:LYS:CB	1:A:145:THR:OG1	2.39	0.58
1:A:254:THR:HG22	2:B:370:TYR:CG	2.39	0.58
1:D:93:TYR:O	2:E:290:HIS:CE1	2.56	0.58
1:F:13:VAL:HG21	1:F:391:PRO:HB2	1.85	0.58
1:H:132:LYS:NZ	1:H:145:THR:OG1	2.36	0.58
1:H:34:LEU:CD1	1:H:132:LYS:CD	2.80	0.58
2:B:296:HIS:O	2:B:297:LYS:CG	2.45	0.58
1:A:34:LEU:CG	1:A:133:LEU:O	2.49	0.58
1:A:129:ALA:C	1:A:147:TYR:HD1	2.06	0.58

*Continued on next page...*

*Continued from previous page...*

Atom-1	Atom-2	Interatomic distance (Å)	Clash overlap (Å)
1:A:11:VAL:HG21	1:A:270:ASN:HB3	1.85	0.58
2:B:332:VAL:CB	2:B:333:PRO:HD3	2.05	0.58
1:H:133:LEU:HG	1:H:134:ARG:N	2.19	0.58
1:A:34:LEU:N	1:A:133:LEU:HB2	2.19	0.58
1:D:218:GLN:HE21	2:G:336:ARG:HH12	1.52	0.58
1:H:9:ASN:ND2	1:H:271:CYS:O	2.37	0.58
1:H:310:SER:N	1:H:390:TYR:CE2	2.27	0.58
1:H:310:SER:HB3	1:H:390:TYR:CA	2.33	0.58
1:H:132:LYS:CG	1:H:145:THR:HG1	1.79	0.57
1:H:133:LEU:HG	1:H:134:ARG:H	1.69	0.57
1:A:52:LYS:NZ	2:B:100:ARG:NH1	2.46	0.57
1:H:257:PHE:CZ	2:I:366:GLU:HG3	2.37	0.57
1:A:95:PHE:N	2:B:290:HIS:CG	2.72	0.57
1:H:74:PRO:HG3	1:H:213:VAL:O	2.03	0.57
1:H:130:SER:C	1:H:147:TYR:HA	2.23	0.57
1:H:359:ALA:CB	2:I:405:GLN:CG	2.67	0.57
1:F:254:THR:CG2	2:G:370:TYR:CD2	2.80	0.57
2:G:116:LEU:HD22	2:G:131:LEU:HD21	1.87	0.57
1:H:309:SER:CA	1:H:388:VAL:HG21	2.34	0.57
2:G:336:ARG:HG3	2:G:337:ASN:N	2.19	0.57
1:A:41:THR:HG21	1:H:123:ARG:O	2.05	0.57
1:A:93:TYR:C	2:B:290:HIS:CD2	2.77	0.57
1:A:291:VAL:H	1:D:305:ALA:N	1.80	0.57
1:D:34:LEU:HD11	1:D:143:THR:HG23	0.59	0.57
1:F:34:LEU:CD1	1:F:132:LYS:HD3	2.30	0.57
1:H:52:LYS:HE3	2:I:100:ARG:HH22	1.63	0.57
1:A:95:PHE:CB	2:B:290:HIS:CB	2.74	0.57
1:F:132:LYS:CG	1:F:133:LEU:H	2.12	0.57
2:I:116:LEU:HD22	2:I:131:LEU:HD21	1.87	0.57
1:D:132:LYS:N	1:D:145:THR:HA	2.20	0.57
1:D:218:GLN:HE21	2:G:336:ARG:NH1	2.02	0.57
1:H:132:LYS:HE3	1:H:143:THR:HG22	1.86	0.57
2:I:236:PRO:CD	2:I:298:LYS:O	2.42	0.57
1:A:126:THR:CB	1:H:175:ASN:OD1	2.53	0.57
1:D:132:LYS:HA	1:D:145:THR:HA	1.80	0.57
1:D:218:GLN:HE22	2:G:336:ARG:HH22	1.52	0.57
1:H:34:LEU:HD12	1:H:132:LYS:CD	2.31	0.57
1:H:310:SER:CA	1:H:388:VAL:CG2	2.81	0.57
2:I:213:LYS:N	2:I:332:VAL:C	2.58	0.57
1:A:94:CYS:O	2:B:290:HIS:HD2	1.86	0.56
1:A:206:ARG:HG3	1:A:206:ARG:HH11	1.70	0.56

*Continued on next page...*

*Continued from previous page...*

Atom-1	Atom-2	Interatomic distance (Å)	Clash overlap (Å)
1:D:385:ASP:OD2	2:E:342:TYR:CD1	2.58	0.56
1:F:95:PHE:CB	2:G:290:HIS:HB3	2.35	0.56
2:G:202:ARG:CD	2:G:396:ASN:HD21	2.18	0.56
2:G:332:VAL:CG2	2:G:333:PRO:HD2	2.35	0.56
1:D:218:GLN:NE2	2:G:336:ARG:HH12	2.02	0.56
1:H:309:SER:O	1:H:390:TYR:CE1	2.48	0.56
2:B:215:LEU:HD12	2:B:332:VAL:HG21	1.87	0.56
2:E:213:LYS:HB3	2:E:333:PRO:CD	2.34	0.56
1:F:13:VAL:CG1	1:F:391:PRO:HG2	2.36	0.56
1:F:95:PHE:CG	2:G:264:LYS:C	2.78	0.56
1:F:132:LYS:HB2	1:F:145:THR:CA	2.34	0.56
2:G:337:ASN:HA	2:G:394:TRP:CD1	2.41	0.56
1:H:206:ARG:HG3	1:H:206:ARG:HH11	1.70	0.56
1:A:175:ASN:OD1	1:H:126:THR:CB	2.54	0.56
1:F:90:GLY:O	2:G:240:PRO:C	2.44	0.56
1:F:310:SER:HG	1:F:388:VAL:CG2	2.04	0.56
2:B:116:LEU:HD22	2:B:131:LEU:HD21	1.87	0.56
1:D:206:ARG:HG3	1:D:206:ARG:HH11	1.70	0.56
2:E:116:LEU:HD22	2:E:131:LEU:HD21	1.87	0.56
1:F:206:ARG:HG3	1:F:206:ARG:HH11	1.70	0.56
1:H:309:SER:C	1:H:388:VAL:CG2	2.55	0.56
2:I:334:LYS:CD	2:I:335:ALA:N	2.50	0.56
1:D:88:MET:HB2	2:E:240:PRO:CD	2.35	0.56
1:H:52:LYS:HG3	2:I:100:ARG:NH2	2.21	0.56
1:A:171:THR:OG1	1:A:172:PRO:CD	2.53	0.56
1:D:13:VAL:HG22	1:D:391:PRO:HG2	0.56	0.56
1:D:93:TYR:C	2:E:290:HIS:HE2	2.09	0.56
1:F:32:GLU:C	1:F:133:LEU:HD12	2.26	0.56
1:H:309:SER:CA	1:H:388:VAL:CG2	2.84	0.56
1:D:132:LYS:CB	1:D:144:VAL:C	2.51	0.55
1:H:309:SER:HA	1:H:388:VAL:CG2	2.36	0.55
2:I:339:THR:O	2:I:340:VAL:HG12	2.06	0.55
1:A:256:PRO:HB2	2:B:368:PRO:HD3	1.68	0.55
1:F:255:ALA:O	2:G:362:ARG:NH1	2.33	0.55
1:H:34:LEU:CD1	1:H:132:LYS:CG	2.37	0.55
1:H:258:GLY:N	2:I:362:ARG:NH1	2.54	0.55
1:A:52:LYS:CE	2:B:100:ARG:NH2	2.66	0.55
1:A:95:PHE:CD1	2:B:290:HIS:N	2.67	0.55
1:A:123:ARG:O	1:H:41:THR:HG21	2.07	0.55
1:D:385:ASP:OD2	2:E:342:TYR:CE1	2.59	0.55
1:H:90:GLY:O	2:I:241:ASP:N	2.39	0.55

*Continued on next page...*

*Continued from previous page...*

Atom-1	Atom-2	Interatomic distance (Å)	Clash overlap (Å)
1:A:91:GLY:O	2:B:240:PRO:CB	2.53	0.55
1:A:41:THR:CG2	1:H:125:HIS:CE1	2.88	0.55
1:A:254:THR:HA	2:B:370:TYR:CD1	2.41	0.55
1:A:92:ALA:C	2:B:290:HIS:NE2	2.59	0.55
1:A:95:PHE:HE1	2:B:289:CYS:CA	2.15	0.55
2:E:213:LYS:CB	2:E:333:PRO:N	2.69	0.55
1:F:256:PRO:CB	2:G:368:PRO:CG	2.82	0.55
1:F:310:SER:N	1:F:388:VAL:CG2	2.70	0.55
1:H:34:LEU:HD13	1:H:132:LYS:HD3	1.87	0.55
2:I:331:ARG:C	2:I:332:VAL:HG23	2.27	0.55
2:I:337:ASN:CB	2:I:397:ASN:ND2	2.70	0.55
1:A:289:ARG:HG2	1:D:305:ALA:HB1	1.88	0.55
1:F:34:LEU:HD11	1:F:143:THR:CA	2.37	0.55
1:F:132:LYS:CG	1:F:143:THR:HG22	2.37	0.55
1:F:385:ASP:OD2	2:G:342:TYR:N	2.40	0.55
1:H:93:TYR:C	2:I:290:HIS:CE1	2.73	0.55
1:H:254:THR:HA	2:I:370:TYR:CD1	2.42	0.55
1:A:95:PHE:HE1	2:B:289:CYS:HA	1.54	0.55
1:D:34:LEU:HD12	1:D:143:THR:CG2	2.28	0.55
1:D:94:CYS:O	2:E:290:HIS:HD2	1.88	0.55
1:H:52:LYS:CD	2:I:100:ARG:HH22	2.20	0.55
1:A:34:LEU:HD21	1:A:134:ARG:CB	2.33	0.54
1:A:95:PHE:HD1	2:B:289:CYS:CA	2.05	0.54
1:D:131:ALA:N	1:D:147:TYR:HA	2.23	0.54
2:E:74:LYS:O	2:E:298:LYS:NZ	2.38	0.54
2:G:203:GLU:OE2	2:G:333:PRO:HB2	2.07	0.54
1:H:133:LEU:O	1:H:143:THR:HA	2.07	0.54
1:A:131:ALA:H	1:A:147:TYR:HA	1.71	0.54
2:E:202:ARG:NE	2:E:396:ASN:OD1	2.40	0.54
1:A:34:LEU:CD1	1:A:133:LEU:O	2.55	0.54
1:H:130:SER:HA	1:H:147:TYR:CB	2.38	0.54
2:B:336:ARG:HG3	2:B:337:ASN:H	1.73	0.54
2:G:236:PRO:HD3	2:G:298:LYS:O	2.08	0.54
1:A:52:LYS:HZ2	2:B:100:ARG:HH12	1.56	0.54
1:H:257:PHE:CZ	2:I:366:GLU:CB	2.89	0.53
1:D:132:LYS:HA	1:D:144:VAL:C	2.28	0.53
1:D:133:LEU:HG	1:D:134:ARG:H	1.66	0.53
2:G:337:ASN:CB	2:G:338:PRO:CD	2.83	0.53
1:H:32:GLU:O	1:H:33:LEU:C	2.47	0.53
1:H:95:PHE:HD1	2:I:289:CYS:HA	1.65	0.53
1:H:310:SER:HB2	1:H:390:TYR:CE2	2.40	0.53

*Continued on next page...*

*Continued from previous page...*

Atom-1	Atom-2	Interatomic distance (Å)	Clash overlap (Å)
2:I:336:ARG:CA	2:I:397:ASN:OD1	2.41	0.53
1:A:112:GLU:HB2	2:B:102:ARG:NH2	2.23	0.53
1:A:256:PRO:CG	2:B:368:PRO:HD2	2.26	0.53
1:D:95:PHE:HA	2:E:290:HIS:CG	2.34	0.53
1:A:385:ASP:OD1	2:B:342:TYR:HD1	1.39	0.53
1:A:95:PHE:HA	2:B:290:HIS:CA	2.34	0.53
1:A:131:ALA:H	1:A:147:TYR:CA	2.22	0.53
2:B:137:HIS:HE1	2:B:293:VAL:HG12	1.70	0.53
1:H:52:LYS:O	1:H:53:THR:N	2.42	0.53
1:H:134:ARG:C	1:H:142:ILE:O	2.48	0.52
1:A:175:ASN:OD1	1:H:126:THR:CG2	2.57	0.52
2:G:334:LYS:HG2	2:G:335:ALA:N	2.24	0.52
1:A:125:HIS:H	1:H:125:HIS:CD2	2.27	0.52
1:A:256:PRO:CG	2:B:368:PRO:HD3	1.99	0.52
1:D:91:GLY:CA	2:E:240:PRO:HB2	2.38	0.52
1:H:310:SER:HB3	1:H:390:TYR:O	2.09	0.52
1:A:290:VAL:N	1:D:305:ALA:HB2	2.25	0.52
1:F:34:LEU:HD11	1:F:133:LEU:O	2.09	0.52
1:H:11:VAL:HG22	1:H:33:LEU:HB3	1.91	0.52
2:E:156:THR:OG1	2:I:88:GLU:CD	2.48	0.52
1:H:93:TYR:CA	2:I:290:HIS:NE2	2.73	0.52
1:H:94:CYS:C	2:I:290:HIS:CG	2.83	0.52
1:A:291:VAL:HG13	1:D:317:ILE:CD1	2.40	0.52
1:H:52:LYS:CD	2:I:100:ARG:NH2	2.73	0.52
1:D:13:VAL:HG13	1:D:391:PRO:C	2.30	0.52
1:D:257:PHE:CD1	2:E:365:GLY:O	2.63	0.52
2:I:339:THR:C	2:I:340:VAL:CG1	2.78	0.52
1:D:13:VAL:CB	1:D:391:PRO:HG2	2.32	0.52
1:A:309:SER:HB2	1:A:390:TYR:OH	2.09	0.51
1:D:11:VAL:HG22	1:D:33:LEU:HB3	1.93	0.51
1:D:88:MET:CE	2:E:237:PRO:CG	2.78	0.51
1:F:257:PHE:CD2	2:G:365:GLY:HA2	2.46	0.51
1:F:257:PHE:CG	1:F:272:ALA:C	2.72	0.51
2:G:137:HIS:CE1	2:G:293:VAL:HB	2.42	0.51
1:H:95:PHE:N	2:I:290:HIS:CB	2.72	0.51
1:D:257:PHE:HA	2:E:364:MET:C	2.31	0.51
1:A:133:LEU:HG	1:A:134:ARG:H	1.66	0.51
2:I:340:VAL:HG11	2:I:349:MET:HG3	1.91	0.51
1:A:125:HIS:CE1	1:H:41:THR:CG2	2.90	0.51
1:A:254:THR:HA	2:B:370:TYR:CG	2.44	0.51
1:D:110:LYS:HG3	1:D:213:VAL:HG11	1.93	0.51

*Continued on next page...*



*Continued from previous page...*

Atom-1	Atom-2	Interatomic distance (Å)	Clash overlap (Å)
1:D:256:PRO:HB3	2:E:368:PRO:N	1.79	0.51
1:D:34:LEU:HD21	1:D:134:ARG:HB2	1.92	0.51
1:F:11:VAL:CG2	1:F:270:ASN:CG	2.54	0.51
1:H:310:SER:OG	1:H:389:ASN:N	2.37	0.51
1:A:126:THR:CG2	1:H:175:ASN:OD1	2.57	0.51
2:E:213:LYS:HB2	2:E:333:PRO:N	2.26	0.51
1:F:129:ALA:O	1:F:147:TYR:CB	2.59	0.51
2:G:334:LYS:CG	2:G:335:ALA:N	2.74	0.51
1:H:11:VAL:HG21	1:H:270:ASN:ND2	2.26	0.51
1:F:34:LEU:CB	1:F:133:LEU:CA	2.88	0.51
2:I:211:HIS:C	2:I:331:ARG:HD2	2.31	0.51
1:D:309:SER:CB	1:D:390:TYR:OH	2.57	0.51
1:F:310:SER:HB3	1:F:390:TYR:N	2.25	0.51
1:A:110:LYS:HG3	1:A:213:VAL:HG11	1.93	0.51
1:F:130:SER:HB2	1:F:147:TYR:CD1	2.46	0.51
1:A:11:VAL:HG21	1:A:270:ASN:CG	2.31	0.50
1:D:52:LYS:NZ	2:E:100:ARG:HH12	2.08	0.50
1:D:129:ALA:O	1:D:147:TYR:CB	2.59	0.50
2:G:236:PRO:CD	2:G:298:LYS:O	2.59	0.50
1:D:256:PRO:N	2:E:368:PRO:CB	2.74	0.50
2:G:88:GLU:OE2	2:I:156:THR:OG1	2.25	0.50
1:H:131:ALA:N	1:H:147:TYR:CA	2.74	0.50
1:A:28:VAL:HG23	1:A:329:ALA:HB1	1.94	0.50
1:D:310:SER:HB3	1:D:390:TYR:CG	2.19	0.50
1:H:34:LEU:CD1	1:H:132:LYS:HD3	2.41	0.50
1:H:112:GLU:HB2	2:I:102:ARG:NH2	2.26	0.50
2:I:337:ASN:OD1	2:I:394:TRP:HB3	2.11	0.50
1:A:125:HIS:CD2	1:H:125:HIS:H	2.27	0.50
1:A:254:THR:CG2	2:B:370:TYR:CD2	2.80	0.50
1:F:95:PHE:HD1	2:G:290:HIS:N	2.09	0.50
1:F:254:THR:HG22	2:G:370:TYR:CD1	2.45	0.50
1:H:92:ALA:O	2:I:240:PRO:HB3	2.11	0.50
1:H:110:LYS:HG3	1:H:213:VAL:HG11	1.93	0.50
2:E:212:GLY:N	2:E:331:ARG:HD2	2.27	0.50
1:F:11:VAL:HG21	1:F:270:ASN:ND2	2.24	0.50
1:H:385:ASP:O	1:H:386:HIS:O	2.30	0.50
2:G:236:PRO:HG3	2:G:300:GLN:HB2	1.93	0.50
1:D:28:VAL:HG23	1:D:329:ALA:HB1	1.94	0.50
1:D:74:PRO:CG	1:D:213:VAL:O	2.56	0.50
2:E:336:ARG:CG	2:E:337:ASN:N	2.54	0.50
1:F:34:LEU:CB	1:F:133:LEU:HA	2.42	0.50

*Continued on next page...*

*Continued from previous page...*

Atom-1	Atom-2	Interatomic distance (Å)	Clash overlap (Å)
1:F:132:LYS:HG2	1:F:144:VAL:O	2.10	0.50
1:A:132:LYS:CG	1:A:133:LEU:N	2.65	0.50
1:F:132:LYS:HB2	1:F:145:THR:CG2	2.41	0.50
1:H:28:VAL:HG23	1:H:329:ALA:HB1	1.94	0.50
1:D:13:VAL:HG11	1:D:391:PRO:HB2	1.93	0.49
1:D:254:THR:HA	2:E:370:TYR:CG	2.47	0.49
1:D:91:GLY:O	2:E:240:PRO:HG2	2.12	0.49
1:D:132:LYS:CA	1:D:144:VAL:C	2.74	0.49
2:E:211:HIS:HB3	1:H:226:ALA:H	1.77	0.49
1:F:116:THR:HG21	2:G:327:ASN:HB3	1.94	0.49
1:F:110:LYS:HG3	1:F:213:VAL:HG11	1.93	0.49
1:H:13:VAL:HG21	1:H:391:PRO:CG	2.33	0.49
1:F:93:TYR:CA	2:G:290:HIS:HE2	2.26	0.49
1:H:259:CYS:N	2:I:362:ARG:NH1	2.52	0.49
1:F:30:GLU:HB3	1:F:136:LEU:HB2	1.95	0.49
1:H:11:VAL:HA	1:H:33:LEU:HB2	1.95	0.49
1:H:30:GLU:HB3	1:H:136:LEU:HB2	1.95	0.49
1:H:95:PHE:CB	2:I:264:LYS:CB	2.90	0.49
1:H:132:LYS:CG	1:H:133:LEU:N	2.64	0.49
2:I:295:ASN:C	2:I:297:LYS:N	2.65	0.49
2:I:335:ALA:HB2	2:I:396:ASN:CB	2.33	0.49
2:G:296:HIS:O	2:G:297:LYS:HG3	2.12	0.49
1:F:132:LYS:HB2	1:F:145:THR:HG23	1.95	0.49
1:A:30:GLU:HB3	1:A:136:LEU:HB2	1.95	0.49
2:E:209:PRO:CG	2:E:331:ARG:CG	2.70	0.49
2:E:332:VAL:HG12	2:E:333:PRO:N	2.19	0.49
1:F:172:PRO:HG3	1:F:268:ALA:CB	2.42	0.49
1:F:217:THR:O	1:F:218:GLN:N	2.45	0.49
1:D:91:GLY:O	2:E:240:PRO:HB2	2.10	0.49
2:E:156:THR:HG21	2:I:88:GLU:OE1	0.67	0.49
1:F:385:ASP:HB2	2:G:342:TYR:HB2	1.95	0.49
2:I:237:PRO:HG3	2:I:306:VAL:CG1	2.42	0.49
1:D:30:GLU:HB3	1:D:136:LEU:HB2	1.95	0.48
1:H:132:LYS:HE2	1:H:143:THR:CG2	2.43	0.48
1:A:130:SER:C	1:A:147:TYR:HA	2.33	0.48
1:F:130:SER:HA	1:F:147:TYR:CD1	2.48	0.48
2:G:332:VAL:CB	2:G:333:PRO:HD2	2.36	0.48
1:A:94:CYS:CA	2:B:290:HIS:CD2	2.97	0.48
1:A:125:HIS:C	1:H:125:HIS:CG	2.86	0.48
2:E:213:LYS:CB	2:E:333:PRO:CD	2.91	0.48
1:H:132:LYS:HE2	1:H:143:THR:HG21	1.95	0.48

*Continued on next page...*

*Continued from previous page...*

Atom-1	Atom-2	Interatomic distance (Å)	Clash overlap (Å)
1:H:170:TRP:CH2	1:H:172:PRO:HB3	2.48	0.48
1:A:125:HIS:CG	1:H:125:HIS:C	2.85	0.48
2:E:236:PRO:HB3	2:E:237:PRO:N	2.28	0.48
1:H:95:PHE:CD1	2:I:289:CYS:CA	2.81	0.48
1:H:170:TRP:CZ2	1:H:256:PRO:CD	2.90	0.48
1:A:52:LYS:O	1:A:53:THR:N	2.45	0.48
1:D:132:LYS:CE	1:D:143:THR:HG22	2.40	0.48
1:F:34:LEU:CD1	1:F:143:THR:OG1	2.61	0.48
1:H:132:LYS:CE	1:H:143:THR:CG2	2.91	0.48
1:A:11:VAL:CG2	1:A:270:ASN:HB3	2.43	0.48
1:D:130:SER:N	1:D:147:TYR:HD1	2.12	0.48
1:D:226:ALA:CB	2:G:211:HIS:HB2	2.44	0.48
1:F:28:VAL:HG23	1:F:329:ALA:HB1	1.94	0.48
1:F:116:THR:HG23	2:G:327:ASN:HB3	1.96	0.48
1:H:310:SER:CB	1:H:390:TYR:CE2	2.84	0.48
1:A:257:PHE:HB3	1:A:273:VAL:CB	2.31	0.48
1:A:94:CYS:C	2:B:290:HIS:CB	2.82	0.48
1:F:34:LEU:CG	1:F:133:LEU:CA	2.80	0.48
1:F:131:ALA:C	1:F:145:THR:HA	2.31	0.48
1:F:271:CYS:HA	1:F:272:ALA:N	2.28	0.48
1:H:131:ALA:CB	1:H:163:VAL:HG11	2.43	0.48
1:H:132:LYS:HG3	1:H:144:VAL:C	2.35	0.48
1:A:94:CYS:C	2:B:290:HIS:HB2	2.34	0.48
1:F:13:VAL:HG11	1:F:391:PRO:HB2	1.96	0.48
1:H:359:ALA:HA	2:I:405:GLN:OE1	2.14	0.48
2:I:77:ARG:HH12	2:I:295:ASN:HD21	1.62	0.48
1:H:95:PHE:HB2	2:I:264:LYS:HB2	1.95	0.47
1:H:132:LYS:CG	1:H:144:VAL:O	2.62	0.47
1:D:257:PHE:CE1	2:E:366:GLU:O	2.65	0.47
1:F:129:ALA:O	1:F:147:TYR:HB3	2.14	0.47
1:F:132:LYS:CE	1:F:143:THR:HG21	2.35	0.47
1:H:34:LEU:HD22	1:H:34:LEU:HA	1.74	0.47
1:A:34:LEU:HD11	1:A:133:LEU:O	2.14	0.47
2:I:336:ARG:HA	2:I:397:ASN:OD1	2.14	0.47
1:A:34:LEU:N	1:A:132:LYS:O	2.47	0.47
1:A:132:LYS:HA	1:A:145:THR:HA	1.88	0.47
2:E:207:SER:HB3	2:I:85:ASP:HB2	1.96	0.47
2:E:297:LYS:O	2:E:298:LYS:CB	2.62	0.47
1:D:218:GLN:NE2	2:G:336:ARG:NH2	2.58	0.47
2:I:338:PRO:HD2	2:I:400:TYR:CZ	2.48	0.47
1:A:170:TRP:CE3	1:A:257:PHE:HD1	2.31	0.47

*Continued on next page...*

*Continued from previous page...*

Atom-1	Atom-2	Interatomic distance (Å)	Clash overlap (Å)
2:B:203:GLU:OE2	2:B:333:PRO:HB2	2.15	0.47
1:D:226:ALA:H	2:G:211:HIS:HB3	1.79	0.47
2:E:336:ARG:NH1	1:H:218:GLN:NE2	2.63	0.47
1:F:11:VAL:HG11	1:F:270:ASN:HD22	1.77	0.47
1:H:129:ALA:O	1:H:147:TYR:HB3	2.13	0.47
1:A:11:VAL:HG21	1:A:270:ASN:CB	2.45	0.47
1:D:34:LEU:CB	1:D:132:LYS:C	2.78	0.47
1:D:88:MET:HE1	2:E:237:PRO:CG	2.27	0.47
1:D:226:ALA:HB2	2:G:211:HIS:HB2	1.95	0.47
2:E:156:THR:CB	2:I:88:GLU:CD	2.68	0.47
1:H:88:MET:HE3	2:I:237:PRO:HG2	1.96	0.47
1:A:60:VAL:HG22	1:A:102:GLN:HG3	1.97	0.47
1:F:93:TYR:O	2:G:290:HIS:NE2	2.47	0.47
1:H:60:VAL:HG22	1:H:102:GLN:HG3	1.97	0.47
1:D:11:VAL:HG23	1:D:33:LEU:HD13	1.96	0.46
1:A:132:LYS:CB	1:A:145:THR:HG23	2.45	0.46
2:E:88:GLU:CD	2:G:156:THR:HG1	2.08	0.46
2:I:332:VAL:HA	2:I:333:PRO:HD3	1.68	0.46
2:B:238:ASP:CG	2:B:294:THR:HG22	2.36	0.46
2:B:296:HIS:C	2:B:297:LYS:HG3	2.31	0.46
1:D:60:VAL:HG22	1:D:102:GLN:HG3	1.98	0.46
1:D:88:MET:HB2	2:E:240:PRO:HD2	1.98	0.46
2:G:334:LYS:CD	2:G:335:ALA:H	2.28	0.46
1:H:359:ALA:HA	2:I:405:GLN:CD	2.36	0.46
2:I:337:ASN:HA	2:I:338:PRO:HD3	1.70	0.46
1:H:91:GLY:O	2:I:240:PRO:HB2	2.16	0.46
1:A:38:LEU:HB2	1:A:268:ALA:HB3	1.98	0.46
1:D:218:GLN:NE2	2:G:336:ARG:HH22	2.12	0.46
1:H:38:LEU:HB2	1:H:268:ALA:HB3	1.98	0.46
2:E:236:PRO:C	2:E:237:PRO:HA	2.36	0.46
1:F:38:LEU:HB2	1:F:268:ALA:HB3	1.98	0.46
1:A:52:LYS:CD	2:B:100:ARG:HH22	2.29	0.46
1:A:52:LYS:CG	2:B:100:ARG:NH2	2.77	0.46
2:G:237:PRO:HG3	2:G:306:VAL:CG1	2.46	0.46
2:G:332:VAL:CG2	2:G:333:PRO:N	2.68	0.46
1:D:34:LEU:CD1	1:D:133:LEU:O	2.64	0.46
1:D:38:LEU:HB2	1:D:268:ALA:HB3	1.98	0.46
1:F:130:SER:CA	1:F:147:TYR:CD1	2.99	0.46
1:H:311:ASP:OD1	1:H:390:TYR:CE2	2.68	0.46
1:A:131:ALA:N	1:A:147:TYR:CA	2.79	0.46
1:F:385:ASP:CB	2:G:342:TYR:HB2	2.45	0.46

*Continued on next page...*

*Continued from previous page...*

Atom-1	Atom-2	Interatomic distance (Å)	Clash overlap (Å)
1:H:13:VAL:HG13	1:H:391:PRO:CB	2.44	0.46
1:A:34:LEU:HD13	1:A:143:THR:HG21	1.89	0.45
1:A:34:LEU:CD2	1:A:133:LEU:C	2.84	0.45
1:H:171:THR:C	1:H:173:PHE:N	2.66	0.45
1:A:132:LYS:HB2	1:A:145:THR:HG23	1.97	0.45
1:D:34:LEU:CD2	1:D:134:ARG:HB2	2.47	0.45
1:F:52:LYS:CE	2:G:100:ARG:HH12	2.30	0.45
1:A:95:PHE:HD1	2:B:289:CYS:C	2.18	0.45
1:D:10:THR:C	1:D:33:LEU:HD12	2.37	0.45
1:D:95:PHE:CA	2:E:290:HIS:CG	2.95	0.45
1:D:131:ALA:N	1:D:147:TYR:CA	2.79	0.45
1:D:310:SER:H	1:D:388:VAL:HG22	1.81	0.45
1:F:34:LEU:HD12	1:F:132:LYS:CD	2.42	0.45
1:A:91:GLY:C	2:B:240:PRO:CB	2.80	0.45
1:D:218:GLN:NE2	2:G:336:ARG:CZ	2.79	0.45
1:H:131:ALA:HB1	1:H:163:VAL:HG11	1.98	0.45
2:I:236:PRO:HB3	2:I:237:PRO:CD	2.45	0.45
1:A:257:PHE:CB	1:A:273:VAL:CG1	2.93	0.45
1:F:310:SER:OG	1:F:389:ASN:N	2.49	0.45
1:A:258:GLY:CA	1:A:272:ALA:CB	2.94	0.45
2:E:332:VAL:HG13	2:E:333:PRO:HD3	1.90	0.45
1:F:60:VAL:HG22	1:F:102:GLN:HG3	1.98	0.45
1:H:34:LEU:HD23	1:H:134:ARG:H	1.50	0.45
2:I:336:ARG:HG3	2:I:337:ASN:N	2.31	0.45
2:B:137:HIS:CE1	2:B:293:VAL:HG11	2.47	0.45
1:F:52:LYS:HE3	2:G:100:ARG:HH22	1.82	0.45
1:H:256:PRO:HA	2:I:368:PRO:HB3	1.34	0.45
1:A:125:HIS:CE1	1:H:125:HIS:O	2.70	0.45
1:F:386:HIS:C	1:F:387:ILE:O	2.48	0.45
1:H:54:VAL:HG21	1:H:109:GLU:OE1	2.17	0.45
1:A:95:PHE:CB	2:B:264:LYS:CB	2.94	0.45
1:F:93:TYR:C	2:G:290:HIS:HE2	2.20	0.45
1:F:192:PHE:CE1	1:F:206:ARG:HG2	2.52	0.45
1:H:192:PHE:CE1	1:H:206:ARG:HG2	2.52	0.45
2:I:334:LYS:HD3	2:I:335:ALA:O	2.17	0.45
1:A:132:LYS:HB2	1:A:145:THR:HA	0.62	0.44
1:A:291:VAL:HB	1:D:315:VAL:CG1	2.46	0.44
2:B:202:ARG:NE	2:B:396:ASN:OD1	2.50	0.44
2:E:137:HIS:NE2	2:E:293:VAL:HG12	2.15	0.44
1:F:34:LEU:HD21	1:F:134:ARG:HA	1.94	0.44
1:A:289:ARG:CA	1:D:305:ALA:CB	2.79	0.44

*Continued on next page...*

*Continued from previous page...*

Atom-1	Atom-2	Interatomic distance (Å)	Clash overlap (Å)
1:H:132:LYS:CG	1:H:144:VAL:C	2.86	0.44
1:A:95:PHE:CD2	2:B:265:CYS:N	2.80	0.44
1:D:130:SER:CA	1:D:147:TYR:HD1	2.18	0.44
2:I:74:LYS:O	2:I:298:LYS:NZ	2.50	0.44
2:I:337:ASN:HA	2:I:394:TRP:HD1	1.82	0.44
1:H:310:SER:HB2	1:H:390:TYR:N	2.30	0.44
1:A:88:MET:HB3	2:B:240:PRO:HD2	1.99	0.44
1:A:258:GLY:HA3	1:A:272:ALA:HB2	2.00	0.44
1:A:310:SER:O	1:A:390:TYR:HD1	1.85	0.44
1:D:192:PHE:CE1	1:D:206:ARG:HG2	2.52	0.44
1:D:218:GLN:HE22	2:G:336:ARG:CZ	2.31	0.44
1:H:11:VAL:HA	1:H:33:LEU:CD1	2.42	0.44
1:A:192:PHE:CE1	1:A:206:ARG:HG2	2.52	0.43
2:E:211:HIS:C	2:E:331:ARG:HD2	2.38	0.43
1:H:308:HIS:O	1:H:383:PRO:HD3	2.17	0.43
1:D:52:LYS:O	1:D:53:THR:N	2.49	0.43
1:H:36:VAL:CG1	1:H:37:THR:N	2.81	0.43
1:A:130:SER:HA	1:A:147:TYR:CB	2.48	0.43
1:D:133:LEU:HD21	1:D:135:VAL:HG22	1.99	0.43
2:E:295:ASN:O	2:E:297:LYS:HG3	2.19	0.43
1:F:310:SER:OG	1:F:388:VAL:CA	2.65	0.43
2:G:203:GLU:CD	2:G:333:PRO:HB2	2.38	0.43
1:H:95:PHE:CE1	2:I:289:CYS:CA	2.76	0.43
2:I:137:HIS:NE2	2:I:293:VAL:HG11	2.29	0.43
2:I:339:THR:HG22	2:I:340:VAL:N	2.27	0.43
1:A:257:PHE:CD2	2:B:365:GLY:CA	3.00	0.43
2:G:215:LEU:HD12	2:G:332:VAL:HG21	1.99	0.43
2:I:77:ARG:HE	2:I:300:GLN:HE21	1.67	0.43
1:A:125:HIS:O	1:H:125:HIS:CE1	2.72	0.43
1:D:34:LEU:H	1:D:133:LEU:CB	2.31	0.43
1:D:133:LEU:HD21	1:D:135:VAL:CG2	2.49	0.43
1:D:254:THR:CG2	2:E:370:TYR:CE2	2.87	0.43
1:F:256:PRO:CB	2:G:365:GLY:O	2.66	0.43
1:H:132:LYS:HG2	1:H:144:VAL:O	2.18	0.43
1:A:91:GLY:CA	2:B:240:PRO:HB2	2.47	0.43
1:A:256:PRO:HG3	2:B:368:PRO:HD2	1.83	0.43
1:D:131:ALA:CB	1:D:163:VAL:HG11	2.49	0.43
2:G:200:ILE:HG22	2:G:332:VAL:HG11	2.00	0.43
1:A:130:SER:N	1:A:147:TYR:HD1	2.17	0.43
1:F:52:LYS:CE	2:G:100:ARG:NH1	2.78	0.43
1:D:34:LEU:HB2	1:D:132:LYS:O	2.18	0.43

*Continued on next page...*

*Continued from previous page...*

Atom-1	Atom-2	Interatomic distance (Å)	Clash overlap (Å)
1:D:91:GLY:C	2:E:240:PRO:CB	2.79	0.43
1:D:254:THR:O	2:E:370:TYR:HB2	2.18	0.43
1:F:254:THR:HG22	2:G:370:TYR:CE2	2.50	0.43
2:B:77:ARG:HE	2:B:300:GLN:HE21	1.67	0.43
1:D:133:LEU:O	1:D:143:THR:HA	2.19	0.42
1:F:133:LEU:O	1:F:143:THR:HA	2.18	0.42
1:H:34:LEU:CD2	1:H:134:ARG:CB	2.87	0.42
1:H:309:SER:OG	1:H:390:TYR:OH	2.11	0.42
2:I:297:LYS:O	2:I:298:LYS:HB2	2.19	0.42
1:A:289:ARG:CD	1:D:305:ALA:HB1	2.49	0.42
1:F:171:THR:O	1:F:171:THR:HG23	2.19	0.42
1:F:171:THR:HG23	1:F:173:PHE:O	2.20	0.42
2:G:77:ARG:HE	2:G:300:GLN:HE21	1.67	0.42
1:H:95:PHE:HE1	2:I:289:CYS:CA	2.26	0.42
1:F:257:PHE:CD2	2:G:365:GLY:CA	3.02	0.42
1:H:386:HIS:C	1:H:387:ILE:O	2.56	0.42
1:A:13:VAL:HG22	1:A:391:PRO:HG2	0.49	0.42
2:E:334:LYS:HG3	2:E:335:ALA:H	1.84	0.42
1:F:132:LYS:O	1:F:133:LEU:HB2	2.19	0.42
1:D:11:VAL:CG2	1:D:33:LEU:HD13	2.49	0.42
1:F:74:PRO:CB	1:F:215:ALA:HB3	2.49	0.42
1:A:34:LEU:HD21	1:A:134:ARG:CA	2.50	0.42
1:A:132:LYS:CB	1:A:145:THR:CG2	2.91	0.42
1:A:164:GLY:HA2	1:A:277:PRO:HD2	2.02	0.42
2:E:77:ARG:HE	2:E:300:GLN:HE21	1.67	0.42
2:E:312:LEU:HD13	2:E:315:ARG:HB2	2.02	0.42
1:F:95:PHE:HD1	2:G:290:HIS:H	1.68	0.42
1:F:256:PRO:CA	2:G:368:PRO:CB	2.90	0.42
1:H:13:VAL:CG2	1:H:391:PRO:CB	2.94	0.42
2:I:331:ARG:NE	2:I:331:ARG:HA	2.31	0.42
1:A:257:PHE:HD2	1:A:273:VAL:HA	1.74	0.42
2:B:237:PRO:HG3	2:B:306:VAL:HG11	1.95	0.42
2:B:312:LEU:HD13	2:B:315:ARG:HB2	2.01	0.42
2:B:332:VAL:HG23	2:B:333:PRO:N	2.35	0.42
2:E:214:GLU:CA	2:E:332:VAL:CG2	2.68	0.42
1:F:164:GLY:HA2	1:F:277:PRO:HD2	2.02	0.42
2:G:336:ARG:CG	2:G:337:ASN:N	2.83	0.42
1:H:132:LYS:HB2	1:H:145:THR:HA	1.88	0.42
1:H:258:GLY:C	2:I:362:ARG:HH22	2.23	0.42
2:G:312:LEU:HD13	2:G:315:ARG:HB2	2.02	0.42
1:H:32:GLU:HB3	1:H:134:ARG:HE	1.85	0.42

*Continued on next page...*

*Continued from previous page...*

Atom-1	Atom-2	Interatomic distance (Å)	Clash overlap (Å)
2:I:340:VAL:HG22	2:I:341:THR:O	2.19	0.42
2:E:156:THR:CG2	2:I:88:GLU:OE2	2.56	0.41
1:F:310:SER:CB	1:F:390:TYR:N	2.83	0.41
1:H:36:VAL:O	1:H:269:VAL:HG13	2.20	0.41
1:A:291:VAL:HG13	1:D:317:ILE:CG1	2.48	0.41
2:B:332:VAL:HB	2:B:333:PRO:HD2	1.94	0.41
2:G:337:ASN:HA	2:G:338:PRO:HD3	1.87	0.41
1:D:164:GLY:HA2	1:D:277:PRO:HD2	2.02	0.41
1:H:164:GLY:HA2	1:H:277:PRO:HD2	2.02	0.41
1:H:257:PHE:CZ	2:I:366:GLU:CG	2.88	0.41
1:H:258:GLY:HA3	1:H:272:ALA:HB2	1.70	0.41
2:I:237:PRO:HD3	2:I:300:GLN:OE1	2.21	0.41
1:A:258:GLY:HA2	2:B:362:ARG:NH1	2.35	0.41
1:D:259:CYS:N	2:E:362:ARG:HH12	2.18	0.41
1:F:34:LEU:HD12	1:F:132:LYS:HG2	2.03	0.41
1:H:33:LEU:HA	1:H:33:LEU:HD23	1.81	0.41
1:A:95:PHE:HB3	2:B:264:LYS:HB3	2.02	0.41
1:D:95:PHE:N	2:E:290:HIS:CG	2.89	0.41
1:F:95:PHE:HD1	2:G:289:CYS:HA	1.74	0.41
1:F:308:HIS:O	1:F:383:PRO:HD3	2.20	0.41
1:H:89:TRP:CZ2	2:I:136:ASN:HB3	2.56	0.41
1:A:89:TRP:CZ2	2:B:136:ASN:HB3	2.56	0.41
1:D:34:LEU:H	1:D:133:LEU:HA	1.82	0.41
1:A:52:LYS:HE3	2:B:100:ARG:HH22	1.80	0.41
1:A:303:VAL:HG21	1:A:378:ALA:HB2	2.03	0.41
1:D:89:TRP:CZ2	2:E:136:ASN:HB3	2.56	0.41
1:D:95:PHE:HB2	2:E:264:LYS:HB2	2.03	0.41
1:D:132:LYS:HA	1:D:145:THR:CA	2.42	0.41
1:H:95:PHE:CB	2:I:264:LYS:HB3	2.50	0.41
2:I:312:LEU:HD13	2:I:315:ARG:HB2	2.01	0.41
1:A:34:LEU:HD12	1:A:132:LYS:CG	2.51	0.41
1:A:41:THR:CA	1:H:125:HIS:CE1	2.99	0.41
1:D:34:LEU:HG	1:D:133:LEU:N	2.26	0.41
1:D:330:VAL:HG11	1:D:354:ILE:HG21	2.03	0.41
1:F:89:TRP:CZ2	2:G:136:ASN:HB3	2.56	0.41
1:F:255:ALA:HA	1:F:256:PRO:HD3	1.98	0.41
1:H:95:PHE:N	2:I:290:HIS:CG	2.89	0.41
2:I:340:VAL:CG2	2:I:341:THR:O	2.69	0.41
1:A:91:GLY:O	2:B:240:PRO:HG2	2.21	0.41
1:A:95:PHE:CD1	2:B:289:CYS:C	2.92	0.41
1:D:256:PRO:HB3	2:E:368:PRO:CA	2.25	0.41

*Continued on next page...*



Continued from previous page...

Atom-1	Atom-2	Interatomic distance (Å)	Clash overlap (Å)
1:F:34:LEU:CD1	1:F:143:THR:HA	2.49	0.41
1:F:303:VAL:HG21	1:F:378:ALA:HB2	2.03	0.41
2:G:332:VAL:HG23	2:G:333:PRO:HD2	1.99	0.41
1:H:303:VAL:HG21	1:H:378:ALA:HB2	2.03	0.41
2:B:237:PRO:HG3	2:B:306:VAL:HG13	1.97	0.40
1:F:310:SER:HB3	1:F:390:TYR:CA	2.46	0.40
1:F:330:VAL:HG11	1:F:354:ILE:HG21	2.03	0.40
2:G:192:PRO:HB3	2:I:206:HIS:CE1	2.55	0.40
1:H:311:ASP:CB	1:H:390:TYR:CD2	2.88	0.40
1:H:330:VAL:HG11	1:H:354:ILE:HG21	2.03	0.40
2:I:383:LEU:HD23	2:I:390:LEU:HD21	2.04	0.40
1:D:303:VAL:HG21	1:D:378:ALA:HB2	2.03	0.40
1:F:129:ALA:C	1:F:147:TYR:CD1	2.81	0.40
2:G:137:HIS:CE1	2:G:293:VAL:CG1	3.04	0.40
1:H:310:SER:HA	1:H:388:VAL:HG11	1.55	0.40
2:I:337:ASN:HB2	2:I:397:ASN:OD1	2.14	0.40
1:A:54:VAL:HG21	1:A:109:GLU:OE1	2.22	0.40
1:F:129:ALA:O	1:F:147:TYR:CG	2.68	0.40
1:H:34:LEU:HD11	1:H:143:THR:HG22	1.92	0.40
1:A:259:CYS:N	2:B:362:ARG:HH12	2.18	0.40
1:D:95:PHE:CG	2:E:264:LYS:HB3	2.56	0.40
1:F:34:LEU:CG	1:F:134:ARG:N	2.63	0.40
1:F:74:PRO:HB3	1:F:215:ALA:HB3	2.03	0.40
1:A:95:PHE:CD2	2:B:264:LYS:C	2.77	0.40

There are no symmetry-related clashes.

## 5.3 Torsion angles [i](#)

### 5.3.1 Protein backbone [i](#)

In the following table, the Percentiles column shows the percent Ramachandran outliers of the chain as a percentile score with respect to all PDB entries followed by that with respect to all EM entries.

The Analysed column shows the number of residues for which the backbone conformation was analysed, and the total number of residues.

Mol	Chain	Analysed	Favoured	Allowed	Outliers	Percentiles
1	A	379/391 (97%)	361 (95%)	13 (3%)	5 (1%)	<b>10</b> 43

Continued on next page...

Continued from previous page...

Mol	Chain	Analysed	Favoured	Allowed	Outliers	Percentiles	
1	D	381/391 (97%)	363 (95%)	12 (3%)	6 (2%)	8	38
1	F	379/391 (97%)	362 (96%)	9 (2%)	8 (2%)	5	30
1	H	381/391 (97%)	358 (94%)	13 (3%)	10 (3%)	4	26
2	B	332/334 (99%)	304 (92%)	21 (6%)	7 (2%)	5	30
2	E	330/334 (99%)	305 (92%)	18 (6%)	7 (2%)	5	30
2	G	332/334 (99%)	302 (91%)	21 (6%)	9 (3%)	4	25
2	I	330/334 (99%)	300 (91%)	23 (7%)	7 (2%)	5	30
All	All	2844/2900 (98%)	2655 (93%)	130 (5%)	59 (2%)	8	30

All (59) Ramachandran outliers are listed below:

Mol	Chain	Res	Type
1	A	387	ILE
2	B	296	HIS
2	B	332	VAL
2	B	333	PRO
1	D	387	ILE
2	E	296	HIS
2	E	297	LYS
2	E	298	LYS
2	E	331	ARG
2	E	333	PRO
1	F	133	LEU
1	F	172	PRO
1	F	385	ASP
1	F	386	HIS
1	F	387	ILE
2	G	296	HIS
2	G	332	VAL
2	G	333	PRO
2	G	338	PRO
2	G	340	VAL
1	H	35	SER
1	H	133	LEU
1	H	135	VAL
1	H	385	ASP
1	H	386	HIS
1	H	387	ILE
2	I	298	LYS
2	I	331	ARG

Continued on next page...

*Continued from previous page...*

Mol	Chain	Res	Type
2	I	333	PRO
2	I	338	PRO
2	I	340	VAL
1	A	126	THR
1	D	126	THR
1	F	126	THR
2	G	295	ASN
1	H	33	LEU
1	H	126	THR
1	H	383	PRO
2	I	296	HIS
1	A	386	HIS
1	D	34	LEU
1	D	386	HIS
2	E	295	ASN
1	F	383	PRO
1	F	384	LYS
2	G	237	PRO
2	B	136	ASN
2	B	237	PRO
2	E	136	ASN
2	G	136	ASN
1	H	172	PRO
2	I	136	ASN
1	A	273	VAL
1	A	384	LYS
2	B	297	LYS
1	D	384	LYS
2	B	295	ASN
1	D	273	VAL
2	G	337	ASN

### 5.3.2 Protein sidechains [i](#)

In the following table, the Percentiles column shows the percent sidechain outliers of the chain as a percentile score with respect to all PDB entries followed by that with respect to all EM entries.

The Analysed column shows the number of residues for which the sidechain conformation was analysed, and the total number of residues.

*Continued on next page...*

*Continued from previous page...*

Mol	Chain	Analysed	Rotameric	Outliers	Percentiles	
1	A	328/328 (100%)	318 (97%)	10 (3%)	36	55
1	D	328/328 (100%)	318 (97%)	10 (3%)	36	55
1	F	328/328 (100%)	319 (97%)	9 (3%)	40	58
1	H	328/328 (100%)	319 (97%)	9 (3%)	40	58
2	B	296/296 (100%)	286 (97%)	10 (3%)	32	51
2	E	296/296 (100%)	284 (96%)	12 (4%)	26	47
2	G	296/296 (100%)	290 (98%)	6 (2%)	50	68
2	I	296/296 (100%)	286 (97%)	10 (3%)	32	51
All	All	2496/2496 (100%)	2420 (97%)	76 (3%)	37	55

All (76) residues with a non-rotameric sidechain are listed below:

Mol	Chain	Res	Type
1	A	89	TRP
1	A	128	SER
1	A	133	LEU
1	A	136	LEU
1	A	230	HIS
1	A	349	ASN
1	A	370	CYS
1	A	384	LYS
1	A	386	HIS
1	A	388	VAL
2	B	222	GLN
2	B	247	GLN
2	B	294	THR
2	B	296	HIS
2	B	312	LEU
2	B	314	ASP
2	B	329	THR
2	B	334	LYS
2	B	336	ARG
2	B	377	HIS
1	D	34	LEU
1	D	89	TRP
1	D	128	SER
1	D	133	LEU

*Continued on next page...*

*Continued from previous page...*

<b>Mol</b>	<b>Chain</b>	<b>Res</b>	<b>Type</b>
1	D	136	LEU
1	D	230	HIS
1	D	349	ASN
1	D	370	CYS
1	D	386	HIS
1	D	388	VAL
2	E	222	GLN
2	E	247	GLN
2	E	296	HIS
2	E	297	LYS
2	E	312	LEU
2	E	314	ASP
2	E	329	THR
2	E	331	ARG
2	E	332	VAL
2	E	334	LYS
2	E	336	ARG
2	E	377	HIS
1	F	89	TRP
1	F	128	SER
1	F	132	LYS
1	F	133	LEU
1	F	136	LEU
1	F	230	HIS
1	F	349	ASN
1	F	370	CYS
1	F	388	VAL
2	G	222	GLN
2	G	247	GLN
2	G	312	LEU
2	G	314	ASP
2	G	329	THR
2	G	377	HIS
1	H	34	LEU
1	H	89	TRP
1	H	128	SER
1	H	134	ARG
1	H	136	LEU
1	H	230	HIS
1	H	349	ASN
1	H	370	CYS
1	H	388	VAL

*Continued on next page...*

*Continued from previous page...*

Mol	Chain	Res	Type
2	I	222	GLN
2	I	247	GLN
2	I	296	HIS
2	I	312	LEU
2	I	314	ASP
2	I	329	THR
2	I	331	ARG
2	I	334	LYS
2	I	340	VAL
2	I	377	HIS

Sometimes sidechains can be flipped to improve hydrogen bonding and reduce clashes. All (29) such sidechains are listed below:

Mol	Chain	Res	Type
1	A	9	ASN
1	A	125	HIS
1	A	222	GLN
1	A	373	GLN
2	B	296	HIS
2	B	300	GLN
2	B	327	ASN
2	B	346	GLN
1	D	218	GLN
1	D	222	GLN
1	D	373	GLN
2	E	327	ASN
2	E	346	GLN
1	F	222	GLN
1	F	373	GLN
2	G	206	HIS
2	G	296	HIS
2	G	300	GLN
2	G	309	ASN
2	G	327	ASN
2	G	346	GLN
1	H	9	ASN
1	H	218	GLN
1	H	222	GLN
1	H	373	GLN
2	I	295	ASN
2	I	296	HIS
2	I	327	ASN

*Continued on next page...*

*Continued from previous page...*

Mol	Chain	Res	Type
2	I	346	GLN

### 5.3.3 RNA [i](#)

There are no RNA molecules in this entry.

### 5.4 Non-standard residues in protein, DNA, RNA chains [i](#)

There are no non-standard protein/DNA/RNA residues in this entry.

### 5.5 Carbohydrates [i](#)

There are no oligosaccharides in this entry.

### 5.6 Ligand geometry [i](#)

There are no ligands in this entry.

### 5.7 Other polymers [i](#)

There are no such residues in this entry.

### 5.8 Polymer linkage issues [i](#)

The following chains have linkage breaks:

Mol	Chain	Number of breaks
1	A	6
1	F	6
1	H	4
1	D	4
2	I	1
2	E	1

All chain breaks are listed below:

Model	Chain	Residue-1	Atom-1	Residue-2	Atom-2	Distance (Å)
1	A	33:LEU	C	34:LEU	N	3.54

*Continued on next page...*

*Continued from previous page...*

Model	Chain	Residue-1	Atom-1	Residue-2	Atom-2	Distance (Å)
1	F	33:LEU	C	34:LEU	N	3.49
1	H	235:GLN	C	236:ALA	N	3.48
1	A	235:GLN	C	236:ALA	N	3.47
1	F	235:GLN	C	236:ALA	N	3.34
1	D	235:GLN	C	236:ALA	N	3.21
1	I	236:PRO	C	237:PRO	N	3.21
1	E	236:PRO	C	237:PRO	N	3.17
1	F	271:CYS	C	272:ALA	N	3.09
1	F	52:LYS	C	53:THR	N	2.43
1	A	217:THR	C	218:GLN	N	2.31
1	D	217:THR	C	218:GLN	N	2.26
1	D	52:LYS	C	53:THR	N	2.23
1	H	52:LYS	C	53:THR	N	2.23
1	A	52:LYS	C	53:THR	N	2.21
1	H	217:THR	C	218:GLN	N	2.15
1	F	217:THR	C	218:GLN	N	2.14
1	A	108:VAL	C	109:GLU	N	2.09
1	H	108:VAL	C	109:GLU	N	2.03
1	D	108:VAL	C	109:GLU	N	2.01
1	F	108:VAL	C	109:GLU	N	2.00
1	A	171:THR	C	172:PRO	N	0.90



## 6 Map visualisation [i](#)

This section contains visualisations of the EMDB entry EMD-1121. These allow visual inspection of the internal detail of the map and identification of artifacts.

No raw map or half-maps were deposited for this entry and therefore no images, graphs, etc. pertaining to the raw map can be shown.

### 6.1 Orthogonal projections [i](#)

#### 6.1.1 Primary map

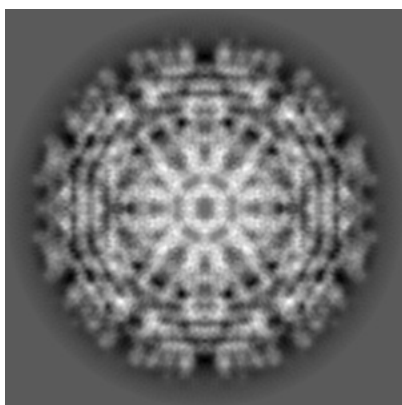

X

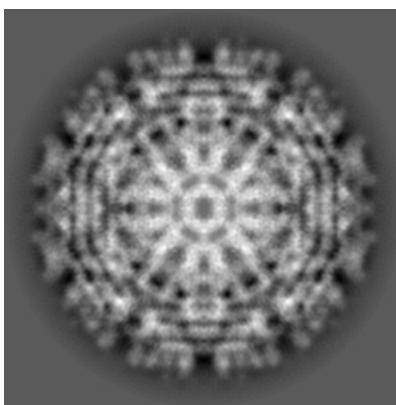

Y

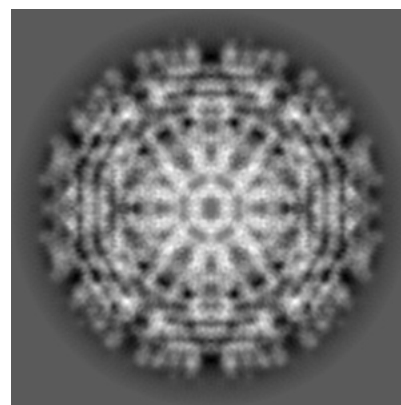

Z

The images above show the map projected in three orthogonal directions.

### 6.2 Central slices [i](#)

#### 6.2.1 Primary map

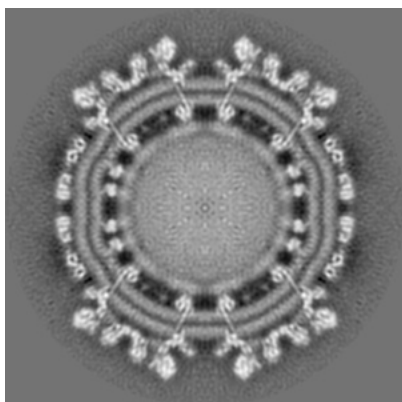

X Index: 220

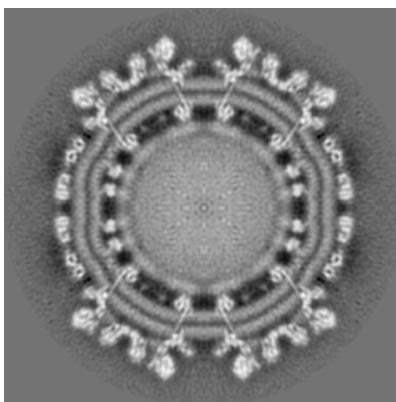

Y Index: 220

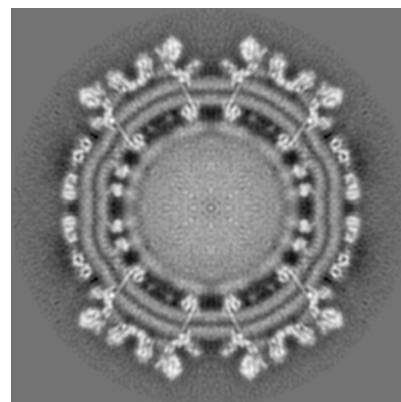

Z Index: 220

The images above show central slices of the map in three orthogonal directions.

## 6.3 Largest variance slices [i](#)

### 6.3.1 Primary map

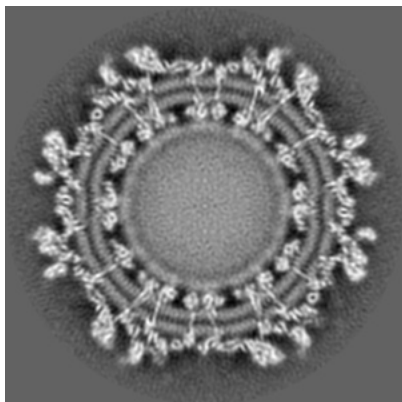

X Index: 202

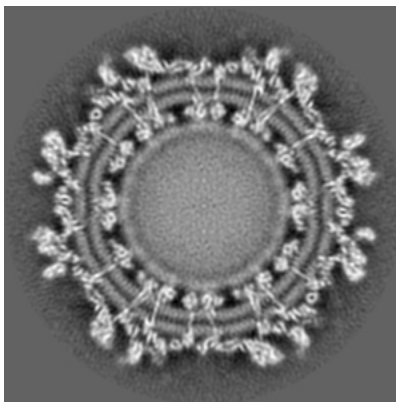

Y Index: 202

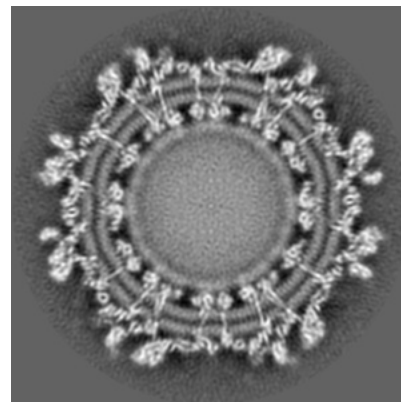

Z Index: 238

The images above show the largest variance slices of the map in three orthogonal directions.

## 6.4 Orthogonal standard-deviation projections (False-color) [i](#)

### 6.4.1 Primary map

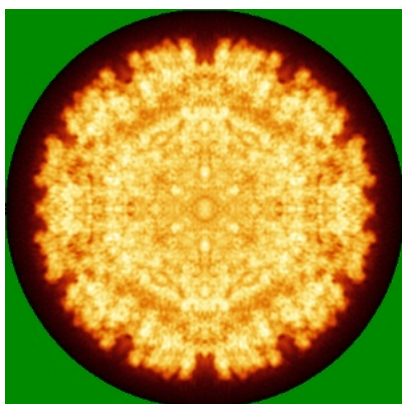

X

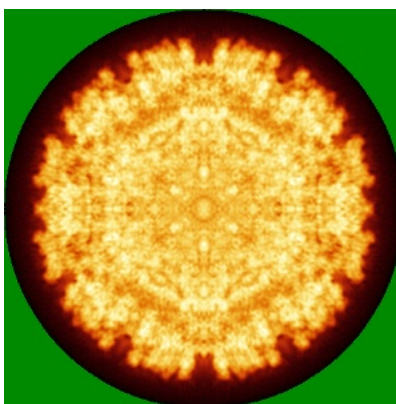

Y

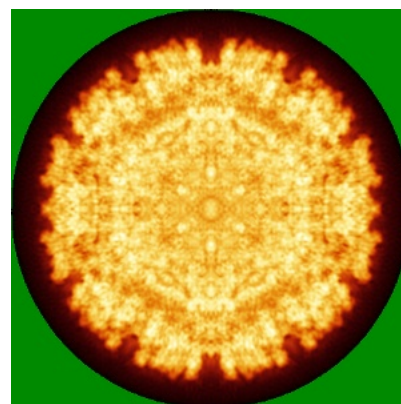

Z

The images above show the map standard deviation projections with false color in three orthogonal directions. Minimum values are shown in green, max in blue, and dark to light orange shades represent small to large values respectively.

## 6.5 Orthogonal surface views [i](#)

### 6.5.1 Primary map



X



Y

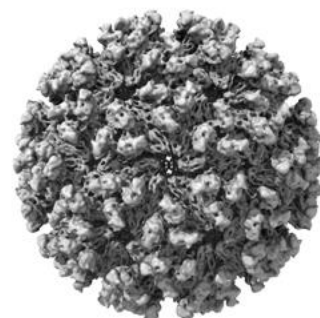

Z

The images above show the 3D surface view of the map at the recommended contour level 138.0. These images, in conjunction with the slice images, may facilitate assessment of whether an appropriate contour level has been provided.

## 6.6 Mask visualisation [i](#)

This section was not generated. No masks/segmentation were deposited.

## 7 Map analysis [i](#)

This section contains the results of statistical analysis of the map.

### 7.1 Map-value distribution [i](#)

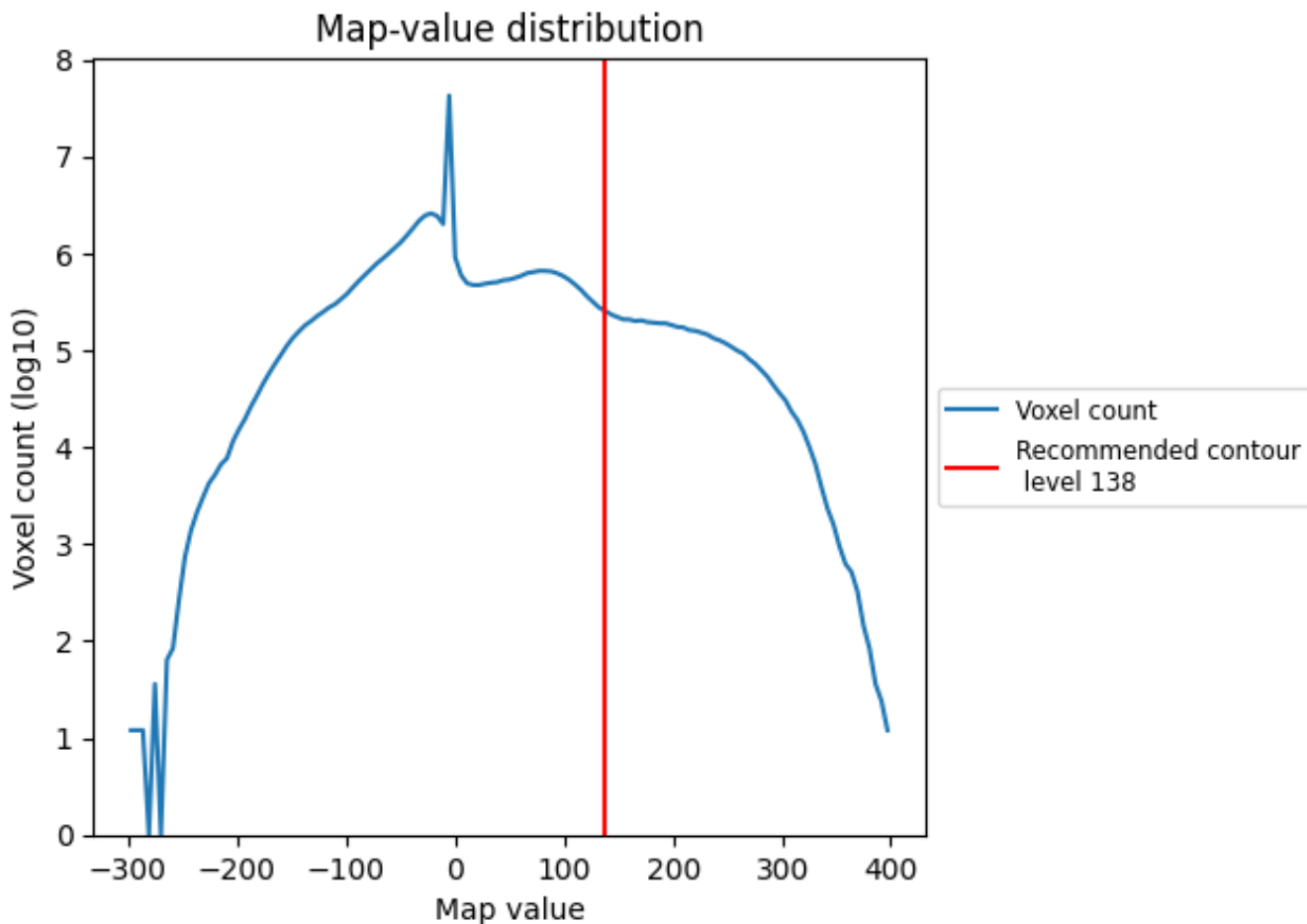

The map-value distribution is plotted in 128 intervals along the x-axis. The y-axis is logarithmic. A spike in this graph at zero usually indicates that the volume has been masked.

## 7.2 Volume estimate [\(i\)](#)

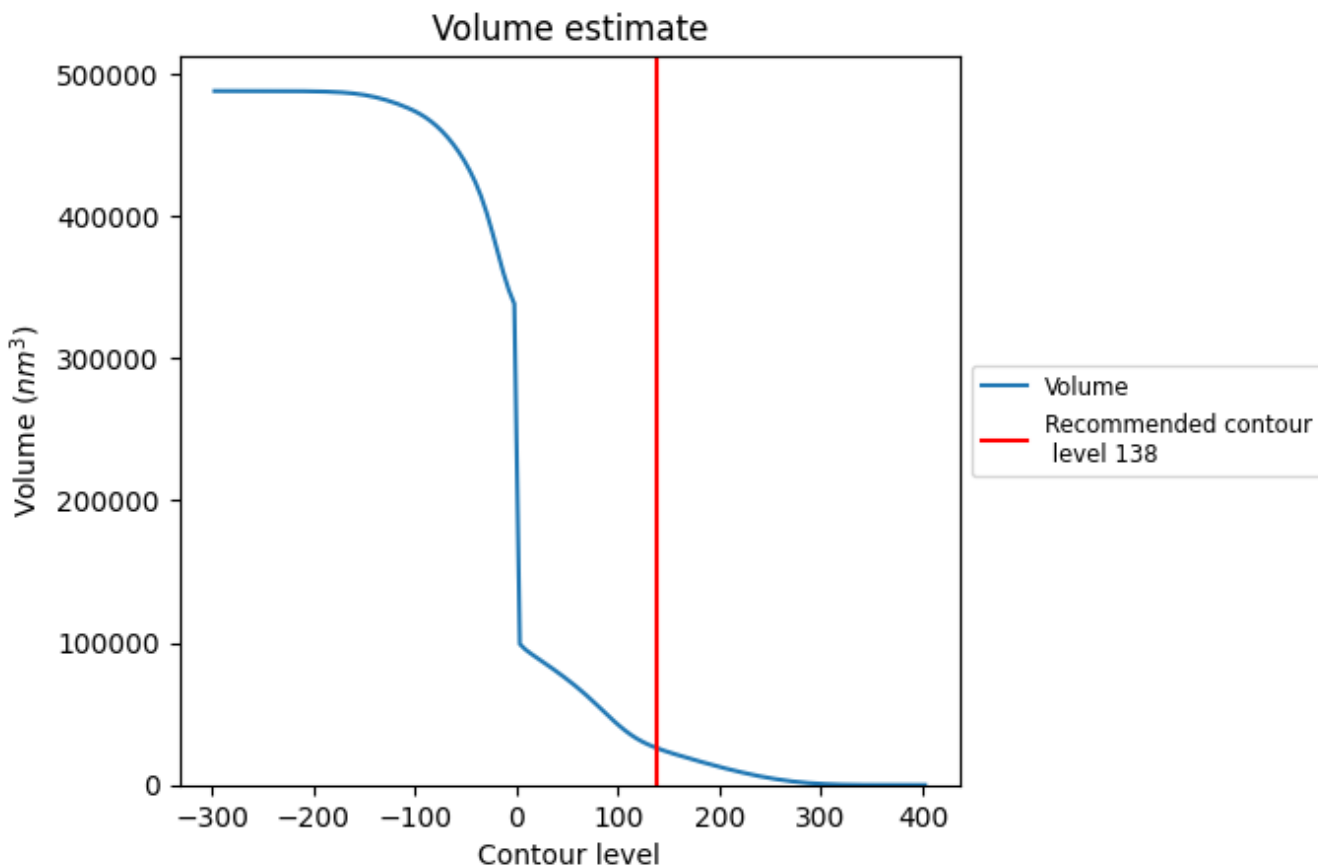

The volume at the recommended contour level is 26000 nm<sup>3</sup>; this corresponds to an approximate mass of 23486 kDa.

The volume estimate graph shows how the enclosed volume varies with the contour level. The recommended contour level is shown as a vertical line and the intersection between the line and the curve gives the volume of the enclosed surface at the given level.

### 7.3 Rotationally averaged power spectrum [i](#)

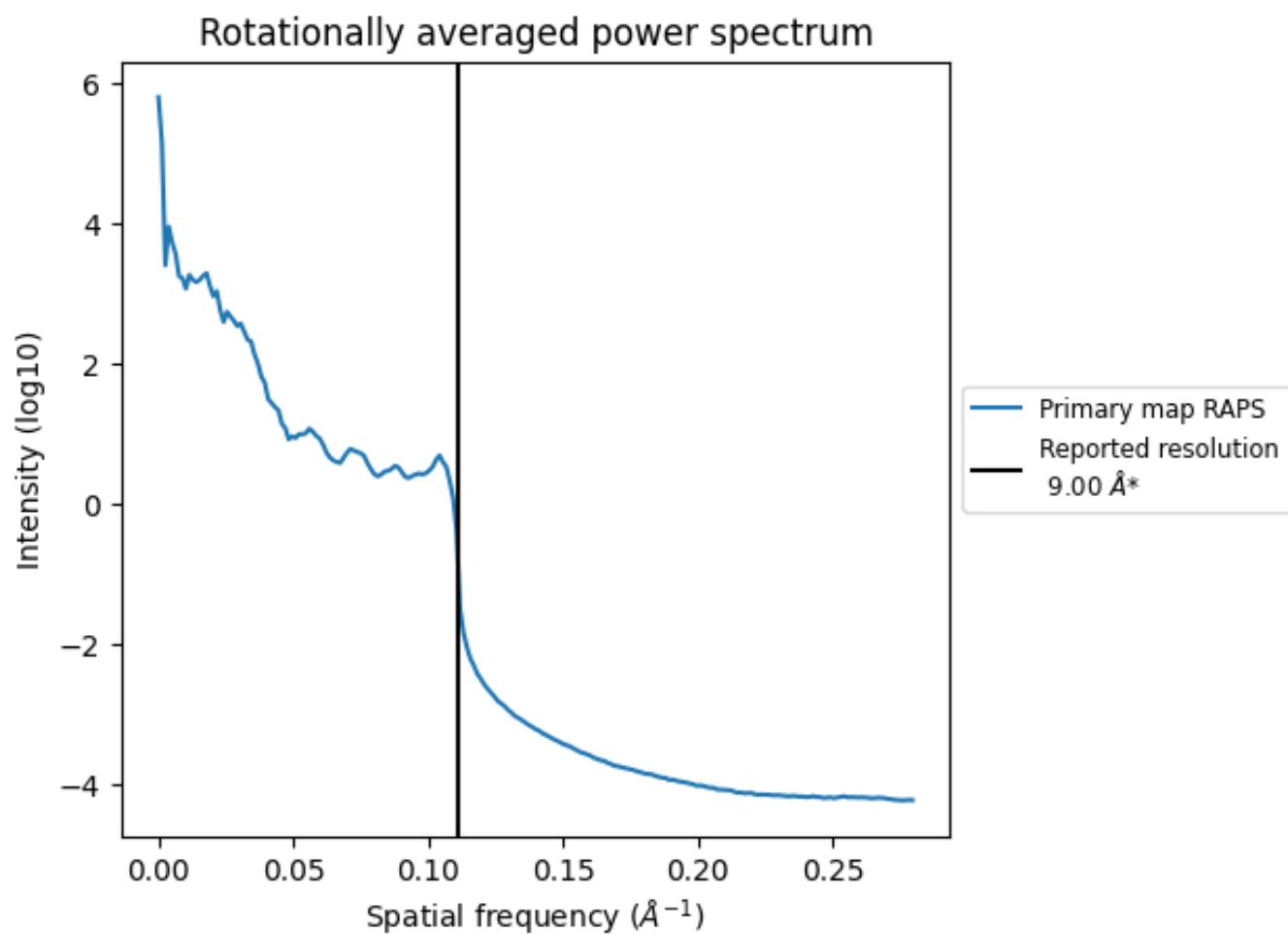

\*Reported resolution corresponds to spatial frequency of  $0.111 \text{\AA}^{-1}$

## 8 Fourier-Shell correlation

This section was not generated. No FSC curve or half-maps provided.

## 9 Map-model fit [i](#)

This section contains information regarding the fit between EMDB map EMD-1121 and PDB model 2XFB. Per-residue inclusion information can be found in section 3 on page 4.

### 9.1 Map-model overlays

#### 9.1.1 Map-model overlay [i](#)

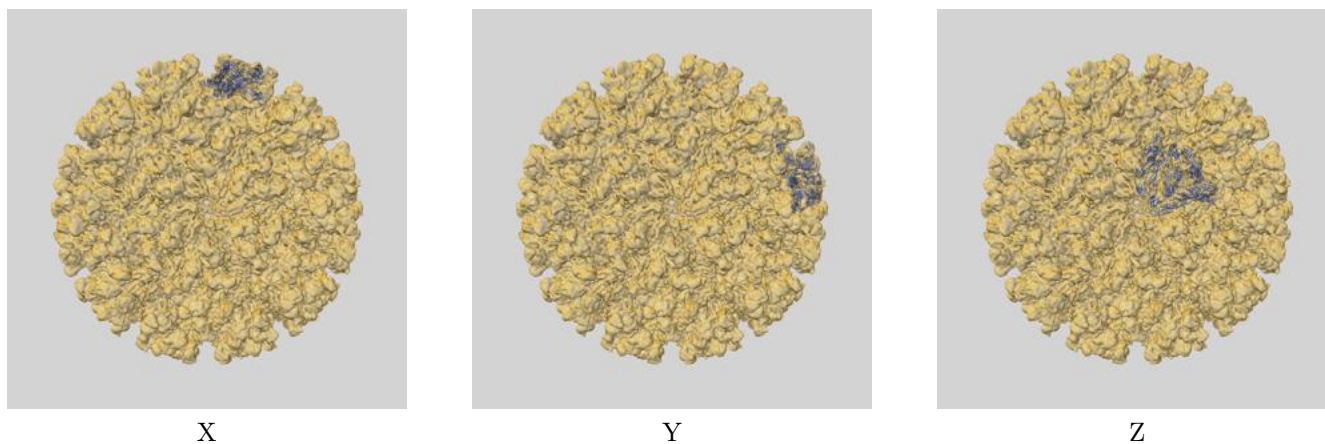

#### 9.1.2 Map-model assembly overlay [i](#)

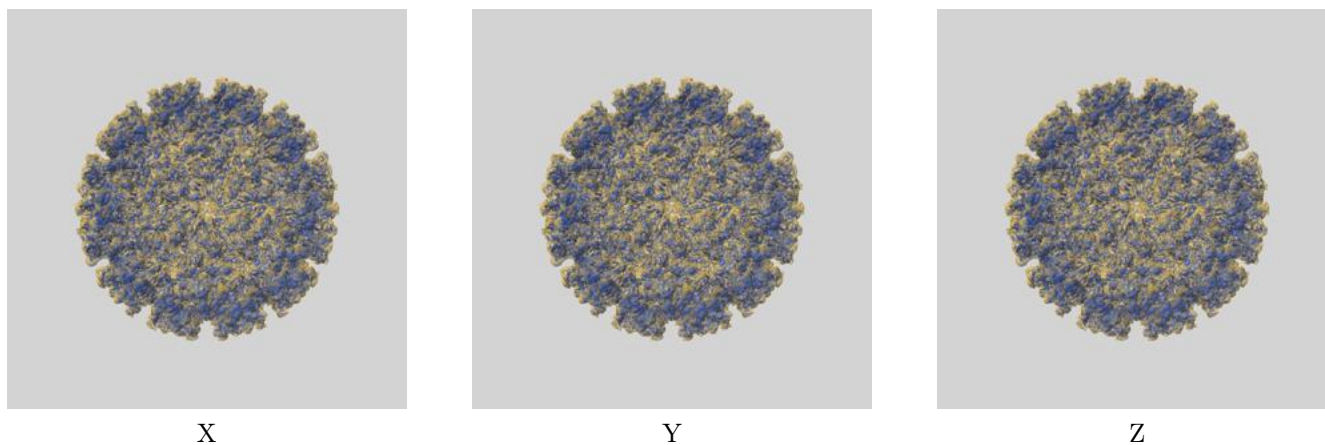

The images above show the 3D surface view of the map at the recommended contour level 138.0 at 50% transparency in yellow overlaid with a ribbon representation of the model coloured in blue. These images allow for the visual assessment of the quality of fit between the atomic model and the map.



## 9.2 Q-score mapped to coordinate model [i](#)

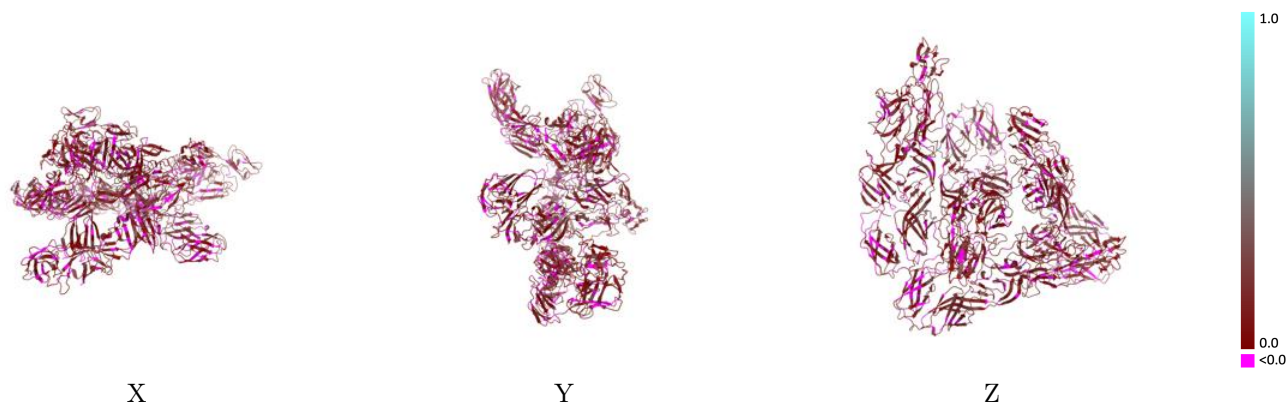

The images above show the model with each residue coloured according to its Q-score. This shows their resolvability in the map with higher Q-score values reflecting better resolvability. Please note: Q-score is calculating the resolvability of atoms, and thus high values are only expected at resolutions at which atoms can be resolved. Low Q-score values may therefore be expected for many entries.

## 9.3 Atom inclusion mapped to coordinate model [i](#)

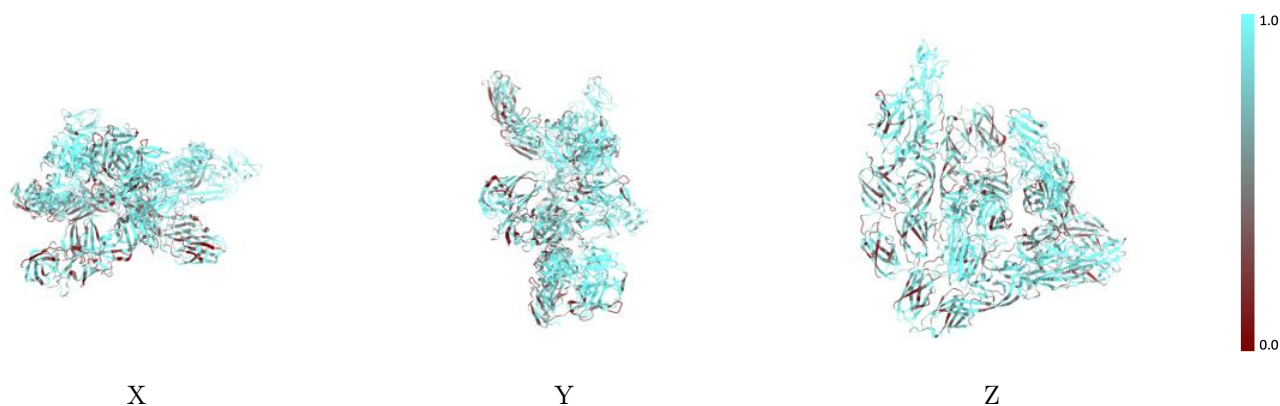

The images above show the model with each residue coloured according to its atom inclusion. This shows to what extent they are inside the map at the recommended contour level (138).



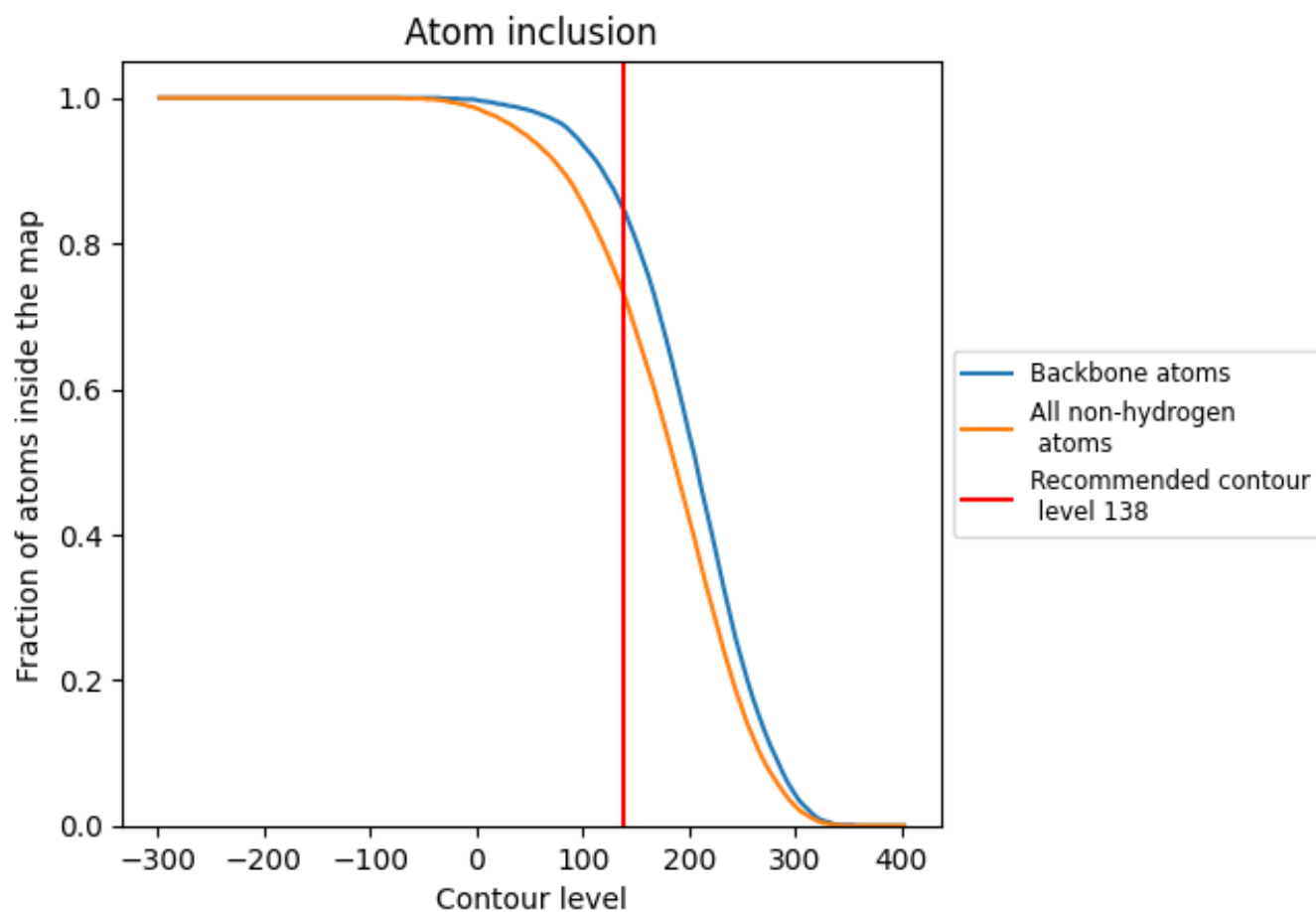















## 9.4 Atom inclusion [i](#)



At the recommended contour level, 85% of all backbone atoms, 73% of all non-hydrogen atoms, are inside the map.

## 9.5 Map-model fit summary

The table lists the average atom inclusion at the recommended contour level (138) and Q-score for the entire model and for each chain.

Chain	Atom inclusion	Q-score
All	 0.7340	 0.1060
A	 0.7170	 0.1060
B	 0.7620	 0.0960
D	 0.7360	 0.1110
E	 0.7440	 0.1040
F	 0.7060	 0.1080
G	 0.7440	 0.1020
H	 0.7160	 0.1110
I	 0.7530	 0.1050

