



Full wwPDB X-ray Structure Validation Report ⓘ

Mar 27, 2026 – 07:09 PM UTC

PDB ID : 5S5Q / pdb_00005s5q
Title : Tubulin-Z396380540-complex
Authors : Muehlethaler, T.; Gioia, D.; Prota, A.E.; Sharpe, M.E.; Cavalli, A.; Steinmetz, M.O.
Deposited on : 2020-11-08
Resolution : 2.05 Å(reported)

This is a Full wwPDB X-ray Structure Validation Report for a publicly released PDB entry.

We welcome your comments at validation@mail.wwpdb.org

A user guide is available at

<https://www.wwpdb.org/validation/2017/XrayValidationReportHelp>

with specific help available everywhere you see the ⓘ symbol.

The types of validation reports are described at

<http://www.wwpdb.org/validation/2017/FAQs#types>.

The following versions of software and data (see [references ⓘ](#)) were used in the production of this report:

MolProbity : 4-5-2 with Phenix2.0
Mogul : 2022.3.0, CSD as543be (2022)
Xtrriage (Phenix) : 2.0
EDS : 3.0
Buster-report : wwPDB partial adaption of 1.1.7 (2018)
Percentile statistics : 20250101.v01 (using entries in the PDB archive January 1st 2025)
CCP4 : 9.0.010 (Gargrove)
Density-Fitness : 1.0.12
Ideal geometry (proteins) : Engh & Huber (2001)
Ideal geometry (DNA, RNA) : Parkinson et al. (1996)
Validation Pipeline (wwPDB-VP) : 2.49

1 Overall quality at a glance

The following experimental techniques were used to determine the structure:

X-RAY DIFFRACTION

The reported resolution of this entry is 2.05 Å.

Percentile scores (ranging between 0-100) for global validation metrics of the entry are shown in the following graphic. The table shows the number of entries on which the scores are based.

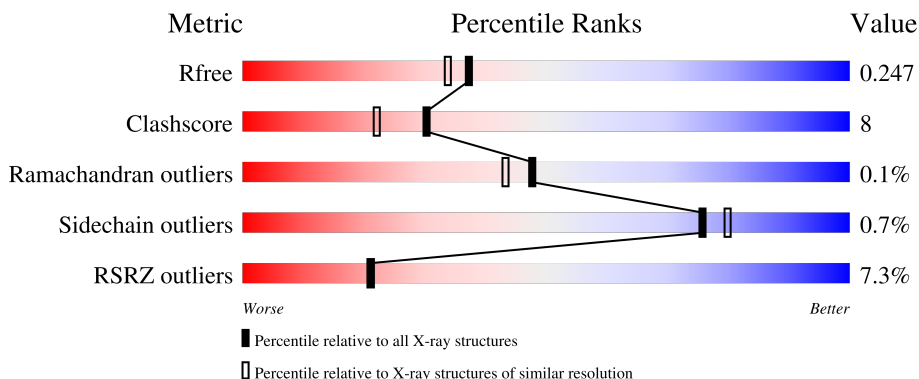

Metric	Whole archive (#Entries)	Similar resolution (#Entries, resolution range(Å))
R_{free}	180053	2260 (2.04-2.04)
Clashscore	190562	2333 (2.04-2.04)
Ramachandran outliers	187476	2318 (2.04-2.04)
Sidechain outliers	187428	2318 (2.04-2.04)
RSRZ outliers	180081	2260 (2.04-2.04)

The table below summarises the geometric issues observed across the polymeric chains and their fit to the electron density. The red, orange, yellow and green segments of the lower bar indicate the fraction of residues that contain outliers for ≥ 3 , 2, 1 and 0 types of geometric quality criteria respectively. A grey segment represents the fraction of residues that are not modelled. The numeric value for each fraction is indicated below the corresponding segment, with a dot representing fractions $\leq 5\%$. The upper red bar (where present) indicates the fraction of residues that have poor fit to the electron density. The numeric value is given above the bar.

Mol	Chain	Length	Quality of chain
1	A	451	 6% 80% 16% ..
1	C	451	 5% 80% 17% .
2	B	445	 8% 72% 22% 5%
2	D	445	 6% 78% 18% .
3	E	143	 8% 76% 10% 14%

Continued on next page...

Continued from previous page...

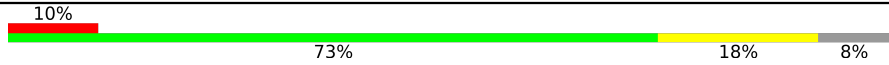
Mol	Chain	Length	Quality of chain
4	F	384	 <p>A horizontal bar chart representing the quality of chain. The bar is divided into four segments: a red segment on the left labeled '10%', a large green segment labeled '73%', a yellow segment labeled '18%', and a small grey segment on the far right labeled '8%'.</p>

2 Entry composition i

There are 12 unique types of molecules in this entry. The entry contains 18094 atoms, of which 17 are hydrogens and 0 are deuteriums.

In the tables below, the ZeroOcc column contains the number of atoms modelled with zero occupancy, the AltConf column contains the number of residues with at least one atom in alternate conformation and the Trace column contains the number of residues modelled with at most 2 atoms.

- Molecule 1 is a protein called Tubulin alpha-1B chain.

Mol	Chain	Residues	Atoms					ZeroOcc	AltConf	Trace
			Total	C	N	O	S			
1	A	438	Total	C	N	O	S	0	0	0
			3424	2167	582	653	22			
1	C	440	Total	C	N	O	S	0	1	0
			3443	2178	585	657	23			

- Molecule 2 is a protein called Tubulin beta-2B chain.

Mol	Chain	Residues	Atoms					ZeroOcc	AltConf	Trace
			Total	C	N	O	S			
2	B	422	Total	C	N	O	S	1	1	0
			3340	2098	573	642	27			
2	D	427	Total	C	N	O	S	5	0	0
			3348	2101	571	649	27			

- Molecule 3 is a protein called Stathmin-4.

Mol	Chain	Residues	Atoms					ZeroOcc	AltConf	Trace
			Total	C	N	O	S			
3	E	123	Total	C	N	O	S	0	0	0
			1014	625	183	201	5			

There are 2 discrepancies between the modelled and reference sequences:

Chain	Residue	Modelled	Actual	Comment	Reference
E	3	MET	-	initiating methionine	UNP P63043
E	4	ALA	-	expression tag	UNP P63043

- Molecule 4 is a protein called Tubulin-Tyrosine Ligase.

Mol	Chain	Residues	Atoms					ZeroOcc	AltConf	Trace
			Total	C	N	O	S			
4	F	352	Total	C	N	O	S	0	0	0
			2877	1843	495	525	14			

There are 6 discrepancies between the modelled and reference sequences:

Chain	Residue	Modelled	Actual	Comment	Reference
F	379	HIS	-	expression tag	UNP E1BQ43
F	380	HIS	-	expression tag	UNP E1BQ43
F	381	HIS	-	expression tag	UNP E1BQ43
F	382	HIS	-	expression tag	UNP E1BQ43
F	383	HIS	-	expression tag	UNP E1BQ43
F	384	HIS	-	expression tag	UNP E1BQ43

- Molecule 5 is GUANOSINE-5'-TRIPHOSPHATE (CCD ID: GTP) (formula: C₁₀H₁₆N₅O₁₄P₃).

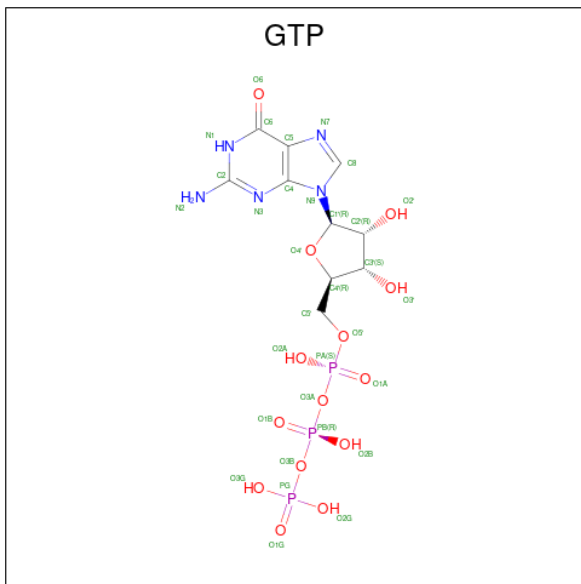

Mol	Chain	Residues	Atoms				ZeroOcc	AltConf	
			Total	C	N	O			P
5	A	1	Total	C	N	O	P	0	0
			32	10	5	14	3		
5	C	1	Total	C	N	O	P	0	0
			32	10	5	14	3		

- Molecule 6 is MAGNESIUM ION (CCD ID: MG) (formula: Mg).

Mol	Chain	Residues	Atoms		ZeroOcc	AltConf
6	A	1	Total	Mg	0	0
			1	1		
6	B	1	Total	Mg	0	0
			1	1		
6	C	1	Total	Mg	0	0
			1	1		
6	D	1	Total	Mg	0	0
			1	1		

Continued on next page...

Continued from previous page...

Mol	Chain	Residues	Atoms		ZeroOcc	AltConf
6	F	1	Total	Mg	0	0
			1	1		

- Molecule 7 is CALCIUM ION (CCD ID: CA) (formula: Ca).

Mol	Chain	Residues	Atoms		ZeroOcc	AltConf
7	A	2	Total	Ca	0	0
			2	2		
7	B	1	Total	Ca	0	0
			1	1		
7	C	1	Total	Ca	0	0
			1	1		

- Molecule 8 is GUANOSINE-5'-DIPHOSPHATE (CCD ID: GDP) (formula: C₁₀H₁₅N₅O₁₁P₂).

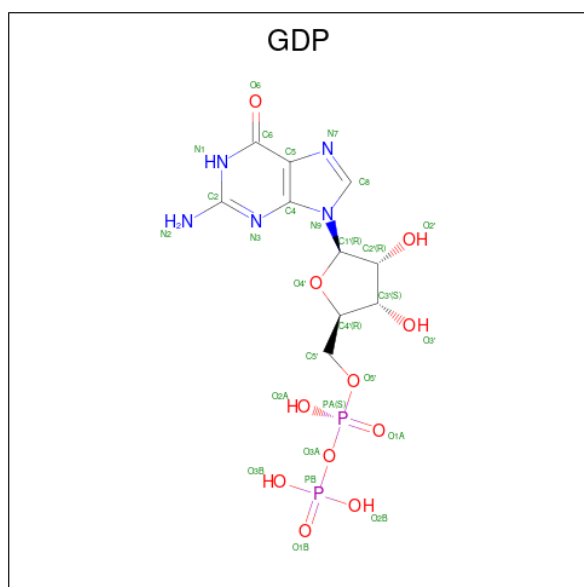

Mol	Chain	Residues	Atoms				ZeroOcc	AltConf	
8	B	1	Total	C	N	O	P	0	0
			28	10	5	11	2		
8	D	1	Total	C	N	O	P	0	0
			28	10	5	11	2		

- Molecule 9 is 2-(N-MORPHOLINO)-ETHANESULFONIC ACID (CCD ID: MES) (formula: C₆H₁₃NO₄S).

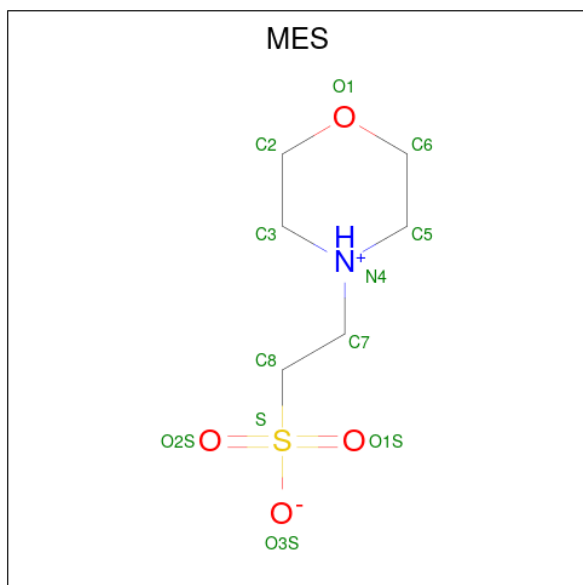

Mol	Chain	Residues	Atoms					ZeroOcc	AltConf
			Total	C	N	O	S		
9	B	1	12	6	1	4	1	0	0

- Molecule 10 is {N}-(cyclobutylmethyl)-1,5-dimethyl-pyrazole-4-carboxamide (CCD ID: HR5) (formula: $C_{11}H_{17}N_3O$) (labeled as "Ligand of Interest" by depositor).

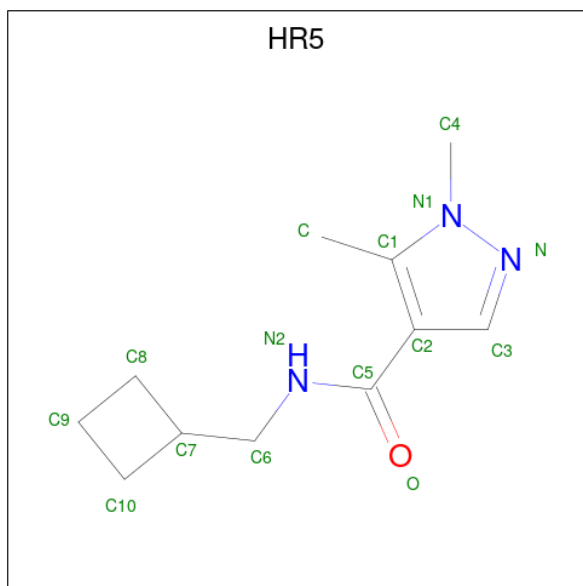

Mol	Chain	Residues	Atoms					ZeroOcc	AltConf
			Total	C	H	N	O		
10	C	1	32	11	17	3	1	0	0

- Molecule 11 is PHOSPHOMETHYLPHOSPHONIC ACID ADENYLATE ESTER (CCD ID: ACP) (formula: $C_{11}H_{18}N_5O_{12}P_3$).

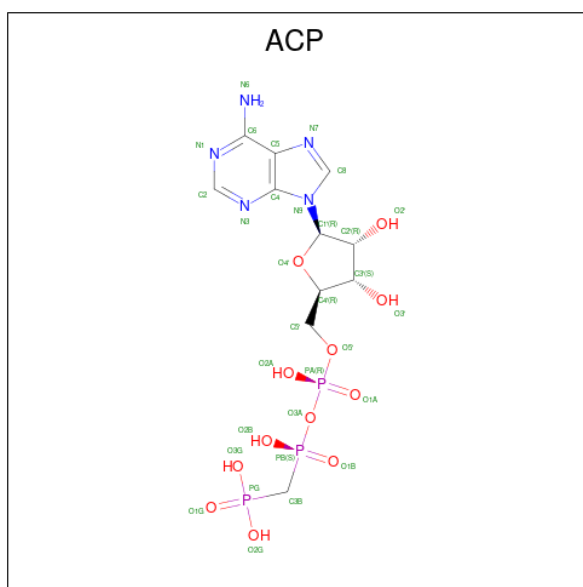

Mol	Chain	Residues	Atoms					ZeroOcc	AltConf
			Total	C	N	O	P		
11	F	1	31	11	5	12	3	0	0

- Molecule 12 is water.

Mol	Chain	Residues	Atoms		ZeroOcc	AltConf
12	A	79	Total	O	0	0
			79	79		
12	B	96	Total	O	0	0
			96	96		
12	C	198	Total	O	0	0
			198	198		
12	D	39	Total	O	0	0
			39	39		
12	E	13	Total	O	0	0
			13	13		
12	F	19	Total	O	0	0
			19	19		

3 Residue-property plots [i](#)

These plots are drawn for all protein, RNA, DNA and oligosaccharide chains in the entry. The first graphic for a chain summarises the proportions of the various outlier classes displayed in the second graphic. The second graphic shows the sequence view annotated by issues in geometry and electron density. Residues are color-coded according to the number of geometric quality criteria for which they contain at least one outlier: green = 0, yellow = 1, orange = 2 and red = 3 or more. A red dot above a residue indicates a poor fit to the electron density ($RSRZ > 2$). Stretches of 2 or more consecutive residues without any outlier are shown as a green connector. Residues present in the sample, but not in the model, are shown in grey.

- Molecule 1: Tubulin alpha-1B chain

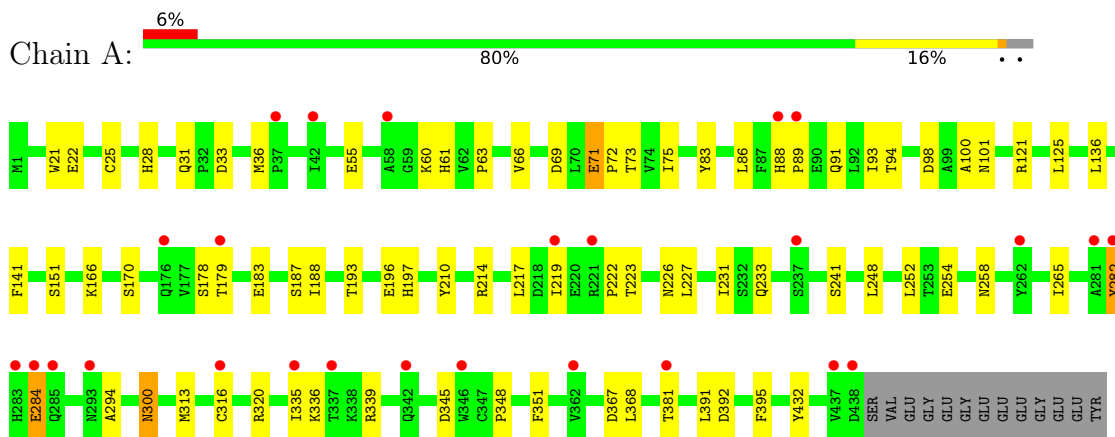

- Molecule 1: Tubulin alpha-1B chain

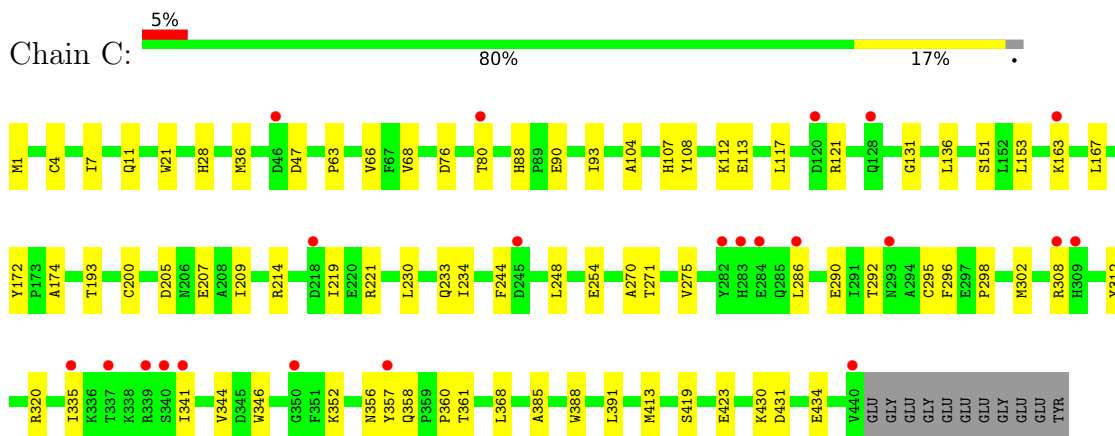

- Molecule 2: Tubulin beta-2B chain

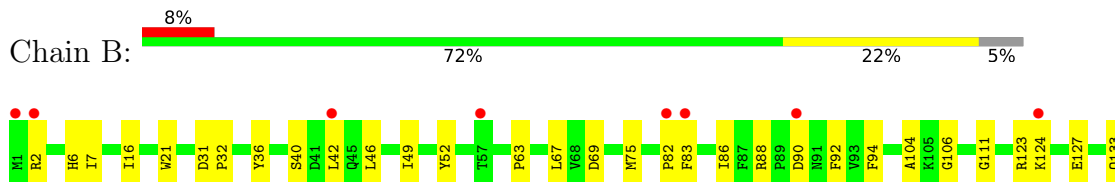

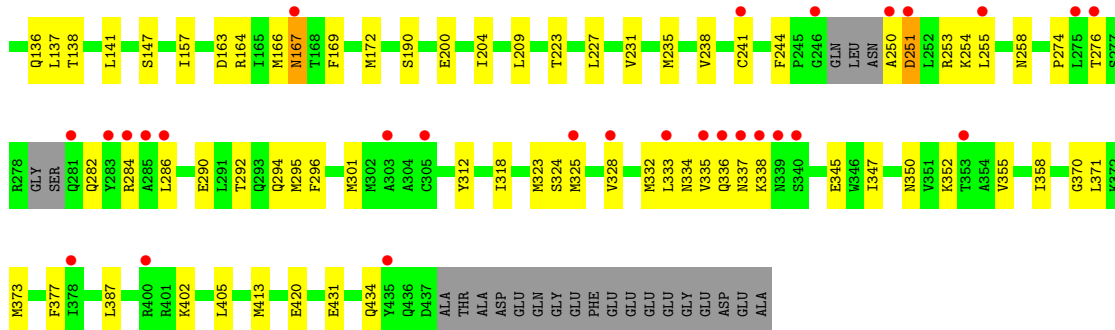

• Molecule 2: Tubulin beta-2B chain

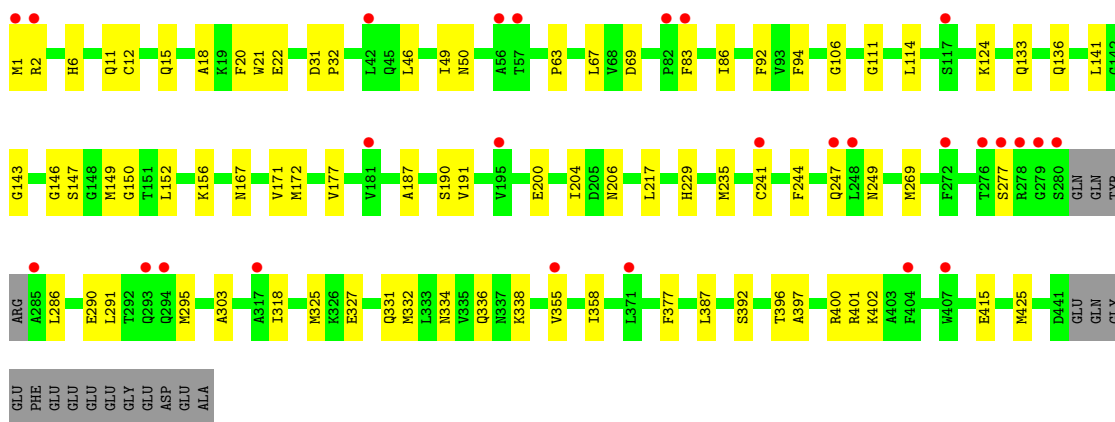
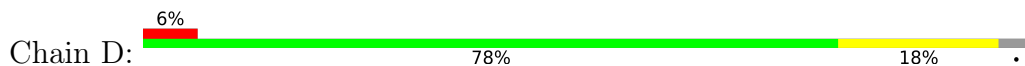

• Molecule 3: Stathmin-4

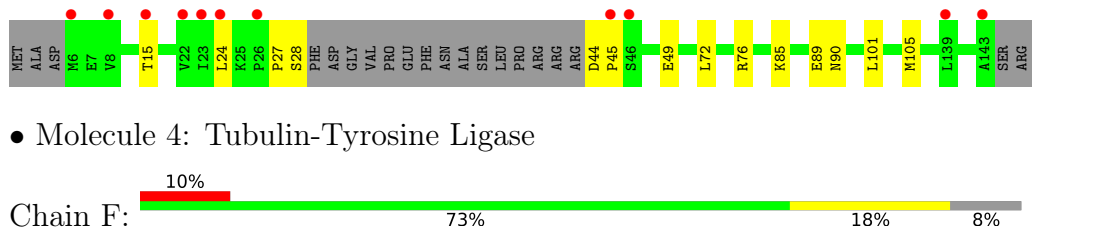
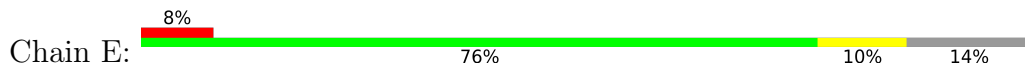

• Molecule 4: Tubulin-Tyrosine Ligase

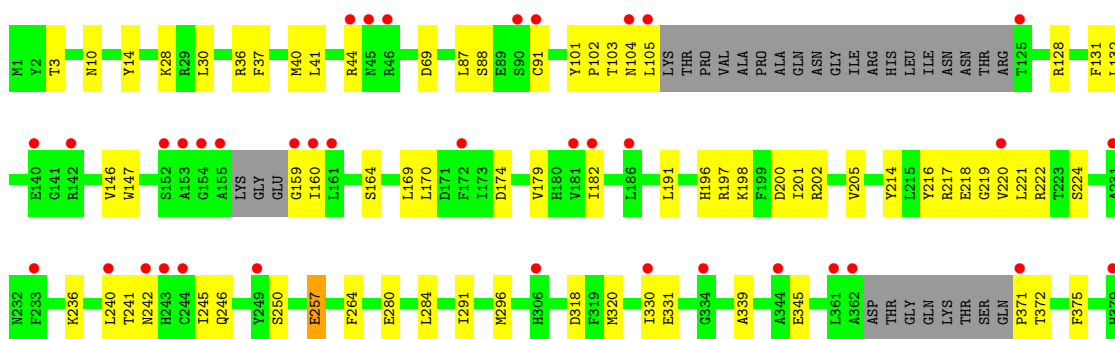



A legend for residue validation. It consists of a vertical bar with four colored segments: yellow, green, red, and grey. Above the bar are two red dots. To the right of the bar, the corresponding residue types are listed: HIS, HIS, HIS, and HIS.

HIS	HIS
HIS	HIS
HIS	HIS
HIS	HIS

4 Data and refinement statistics

Property	Value	Source
Space group	P 21 21 21	Depositor
Cell constants a, b, c, α , β , γ	104.85Å 158.62Å 178.62Å 90.00° 90.00° 90.00°	Depositor
Resolution (Å)	90.42 – 2.05 90.42 – 2.05	Depositor EDS
% Data completeness (in resolution range)	99.8 (90.42-2.05) 99.8 (90.42-2.05)	Depositor EDS
R_{merge}	0.08	Depositor
R_{sym}	(Not available)	Depositor
$\langle I/\sigma(I) \rangle$ ¹	1.16 (at 2.05Å)	Xtrriage
Refinement program	PHENIX 1.18.2_3874	Depositor
R, R_{free}	0.212 , 0.244 0.216 , 0.247	Depositor DCC
R_{free} test set	9367 reflections (5.02%)	wwPDB-VP
Wilson B-factor (Å ²)	48.4	Xtrriage
Anisotropy	0.228	Xtrriage
Bulk solvent k_{sol} (e/Å ³), B_{sol} (Å ²)	0.33 , 41.1	EDS
L-test for twinning ²	$\langle L \rangle = 0.50$, $\langle L^2 \rangle = 0.34$	Xtrriage
Estimated twinning fraction	No twinning to report.	Xtrriage
F_o, F_c correlation	0.96	EDS
Total number of atoms	18094	wwPDB-VP
Average B, all atoms (Å ²)	64.0	wwPDB-VP

Xtrriage's analysis on translational NCS is as follows: *The largest off-origin peak in the Patterson function is 2.32% of the height of the origin peak. No significant pseudotranslation is detected.*

¹Intensities estimated from amplitudes.

²Theoretical values of $\langle |L| \rangle$, $\langle L^2 \rangle$ for acentric reflections are 0.5, 0.333 respectively for untwinned datasets, and 0.375, 0.2 for perfectly twinned datasets.

5 Model quality [i](#)

5.1 Standard geometry [i](#)

Bond lengths and bond angles in the following residue types are not validated in this section: GDP, MES, MG, HR5, GTP, CA, ACP

The Z score for a bond length (or angle) is the number of standard deviations the observed value is removed from the expected value. A bond length (or angle) with $|Z| > 5$ is considered an outlier worth inspection. RMSZ is the root-mean-square of all Z scores of the bond lengths (or angles).

Mol	Chain	Bond lengths		Bond angles	
		RMSZ	# Z >5	RMSZ	# Z >5
1	A	0.11	0/3502	0.29	0/4754
1	C	0.14	0/3521	0.33	0/4780
2	B	0.11	0/3413	0.29	0/4618
2	D	0.10	0/3421	0.27	0/4633
3	E	0.10	0/1022	0.23	0/1356
4	F	0.09	0/2944	0.28	0/3978
All	All	0.11	0/17823	0.29	0/24119

There are no bond length outliers.

There are no bond angle outliers.

There are no chirality outliers.

There are no planarity outliers.

5.2 Too-close contacts [i](#)

In the following table, the Non-H and H(model) columns list the number of non-hydrogen atoms and hydrogen atoms in the chain respectively. The H(added) column lists the number of hydrogen atoms added and optimized by MolProbity. The Clashes column lists the number of clashes within the asymmetric unit, whereas Symm-Clashes lists symmetry-related clashes.

Mol	Chain	Non-H	H(model)	H(added)	Clashes	Symm-Clashes
1	A	3424	0	3334	57	0
1	C	3443	0	3352	48	0
2	B	3340	0	3222	76	0
2	D	3348	0	3227	57	0
3	E	1014	0	1029	10	0
4	F	2877	0	2839	55	0
5	A	32	0	12	1	0

Continued on next page...

Continued from previous page...

Mol	Chain	Non-H	H(model)	H(added)	Clashes	Symm-Clashes
5	C	32	0	12	0	0
6	A	1	0	0	0	0
6	B	1	0	0	0	0
6	C	1	0	0	0	0
6	D	1	0	0	0	0
6	F	1	0	0	0	0
7	A	2	0	0	0	0
7	B	1	0	0	0	0
7	C	1	0	0	0	0
8	B	28	0	12	0	0
8	D	28	0	12	2	0
9	B	12	0	12	2	0
10	C	15	17	0	0	0
11	F	31	0	14	3	0
12	A	79	0	0	3	0
12	B	96	0	0	3	0
12	C	198	0	0	2	0
12	D	39	0	0	1	0
12	E	13	0	0	1	0
12	F	19	0	0	1	0
All	All	18077	17	17077	292	0

The all-atom clashscore is defined as the number of clashes found per 1000 atoms (including hydrogen atoms). The all-atom clashscore for this structure is 8.

All (292) close contacts within the same asymmetric unit are listed below, sorted by their clash magnitude.

Atom-1	Atom-2	Interatomic distance (Å)	Clash overlap (Å)
2:D:217:LEU:HA	2:D:277:SER:HB3	1.47	0.94
4:F:102:PRO:HG2	4:F:105:LEU:HD13	1.50	0.89
1:C:221:ARG:HG3	2:D:325:MET:HG2	1.53	0.89
1:A:71:GLU:OE2	1:A:73:THR:OG1	1.97	0.82
4:F:236:LYS:HB3	4:F:240:LEU:HD13	1.59	0.82
4:F:241:THR:OG1	11:F:401:ACP:O3'	1.98	0.81
2:B:253[A]:ARG:NH1	9:B:504:MES:O2S	2.15	0.78
1:A:335:ILE:HG23	1:A:339:ARG:HG3	1.64	0.78
1:C:209:ILE:HD11	1:C:302:MET:HE3	1.65	0.78
1:C:270:ALA:O	1:C:302:MET:HG2	1.85	0.75
1:A:336:LYS:HG3	3:E:24:LEU:HD13	1.68	0.75
1:C:47:ASP:OD2	12:C:601:HOH:O	2.05	0.75
2:B:2:ARG:HB2	2:B:133:GLN:HG3	1.69	0.75

Continued on next page...

Continued from previous page...

Atom-1	Atom-2	Interatomic distance (Å)	Clash overlap (Å)
2:D:1:MET:HE2	2:D:50:ASN:HB2	1.70	0.73
1:C:4[A]:CYS:SG	1:C:136:LEU:HG	2.29	0.72
1:A:100:ALA:HA	2:B:254:LYS:HG3	1.70	0.72
1:C:76:ASP:O	1:C:80:THR:HG22	1.91	0.71
2:B:274:PRO:HB3	2:B:286:LEU:HD22	1.72	0.71
2:B:167:ASN:OD1	2:B:200:GLU:HB2	1.91	0.71
2:D:334:ASN:HD21	2:D:338:LYS:HE3	1.56	0.69
2:B:284:ARG:NH2	2:B:290:GLU:OE2	2.26	0.68
2:B:325:MET:HE2	2:B:355:VAL:HB	1.76	0.68
1:C:271:THR:HG21	1:C:295:CYS:O	1.94	0.67
2:D:2:ARG:NH1	12:D:602:HOH:O	2.27	0.67
2:B:83:PHE:O	2:B:86:ILE:HG22	1.95	0.66
1:A:345:ASP:HB3	3:E:28:SER:HB2	1.76	0.66
2:D:136:GLN:HA	2:D:167:ASN:O	1.95	0.66
4:F:10:ASN:HB2	4:F:44:ARG:HH22	1.61	0.65
4:F:128:ARG:NH2	4:F:174:ASP:OD1	2.29	0.65
4:F:318:ASP:OD2	11:F:401:ACP:O2G	2.14	0.65
2:D:11:GLN:O	2:D:15:GLN:HG2	1.97	0.65
2:B:324:SER:O	2:B:328:VAL:HG23	1.96	0.65
4:F:102:PRO:HG2	4:F:105:LEU:CD1	2.25	0.65
2:D:83:PHE:O	2:D:86:ILE:HG22	1.97	0.65
2:B:337:ASN:OD1	4:F:36:ARG:HD3	1.97	0.64
4:F:242:ASN:HD22	4:F:245:ILE:HD12	1.62	0.64
4:F:371:PRO:HA	4:F:372:THR:O	1.98	0.64
2:D:269:MET:HG3	2:D:303:ALA:HB3	1.80	0.64
2:B:420:GLU:OE1	12:B:601:HOH:O	2.15	0.64
2:B:274:PRO:HB3	2:B:286:LEU:CD2	2.29	0.63
2:D:1:MET:HG3	2:D:50:ASN:HB2	1.79	0.63
1:A:226:ASN:ND2	1:A:367:ASP:OD2	2.32	0.63
2:B:286:LEU:HD12	2:B:290:GLU:OE1	1.99	0.62
4:F:3:THR:HB	4:F:30:LEU:HD11	1.80	0.62
4:F:371:PRO:HA	4:F:372:THR:HB	1.81	0.62
4:F:159:GLY:C	4:F:160:ILE:HD12	2.24	0.62
2:D:21:TRP:CZ3	2:D:63:PRO:HB3	2.36	0.60
2:D:172:MET:HG3	2:D:387:LEU:HD11	1.84	0.60
1:C:244:PHE:CD1	1:C:358:GLN:HG2	2.35	0.60
2:B:163:ASP:OD1	12:B:602:HOH:O	2.17	0.60
1:A:71:GLU:HG2	1:A:72:PRO:HD2	1.84	0.59
2:B:347:ILE:HG22	2:B:350:ASN:HB3	1.84	0.59
4:F:246:GLN:O	4:F:250:SER:HB3	2.02	0.59
2:B:147:SER:HG	2:B:190:SER:HG	1.49	0.59

Continued on next page...

Continued from previous page...

Atom-1	Atom-2	Interatomic distance (Å)	Clash overlap (Å)
1:C:1:MET:HE3	1:C:131:GLY:HA3	1.83	0.59
2:B:164:ARG:HD2	12:B:675:HOH:O	2.02	0.59
2:D:124:LYS:C	2:D:124:LYS:HD3	2.27	0.59
4:F:371:PRO:CA	4:F:372:THR:HB	2.32	0.59
4:F:197:ARG:NH1	4:F:257:GLU:OE2	2.26	0.59
1:C:93:ILE:HD11	1:C:121:ARG:HG3	1.84	0.59
2:B:69:ASP:O	2:B:94:PHE:HA	2.03	0.58
1:A:254:GLU:HG2	1:A:258:ASN:ND2	2.19	0.58
1:C:320:ARG:HA	1:C:356:ASN:O	2.03	0.58
2:D:397:ALA:O	2:D:401:ARG:NH1	2.36	0.58
2:B:157:ILE:HG21	2:B:166:MET:HE1	1.84	0.57
3:E:85:LYS:O	3:E:89:GLU:HG3	2.02	0.57
4:F:371:PRO:HA	4:F:372:THR:C	2.28	0.57
1:A:335:ILE:HG23	1:A:339:ARG:CG	2.33	0.57
1:C:214:ARG:HG2	1:C:219:ILE:O	2.05	0.57
2:D:334:ASN:ND2	2:D:338:LYS:HE3	2.19	0.57
1:A:36:MET:HB3	1:A:61:HIS:CE1	2.39	0.57
2:B:141:LEU:HD12	2:B:172:MET:SD	2.45	0.57
1:C:419:SER:O	1:C:423:GLU:HG3	2.03	0.57
2:B:21:TRP:CZ3	2:B:63:PRO:HB3	2.40	0.56
2:B:67:LEU:HD22	2:B:92:PHE:CE2	2.40	0.56
1:C:254:GLU:HG2	1:C:352:LYS:HE2	1.88	0.56
2:D:295:MET:HE2	2:D:377:PHE:HB2	1.88	0.56
2:B:88:ARG:NH1	2:B:90:ASP:HB2	2.21	0.56
1:A:265:ILE:HG23	1:A:432:TYR:CE1	2.41	0.55
2:B:2:ARG:HB2	2:B:133:GLN:CG	2.36	0.55
2:B:295:MET:CG	2:B:377:PHE:HB2	2.36	0.55
1:A:300:ASN:HB3	12:A:602:HOH:O	2.06	0.55
2:D:392:SER:HB2	2:D:425:MET:HE3	1.89	0.55
4:F:91:CYS:HA	12:F:518:HOH:O	2.06	0.55
1:C:275:VAL:HG13	1:C:368:LEU:HD21	1.87	0.55
2:B:124:LYS:HD3	2:B:124:LYS:C	2.32	0.55
2:B:250:ALA:O	2:B:251:ASP:HB3	2.07	0.55
2:D:1:MET:HG3	2:D:50:ASN:CB	2.37	0.54
4:F:132:LEU:HD21	4:F:170:LEU:HD11	1.88	0.54
1:A:210:TYR:CE1	1:A:222:PRO:HD2	2.43	0.54
1:A:284:GLU:CD	1:A:284:GLU:H	2.16	0.54
1:A:196:GLU:OE1	1:A:196:GLU:HA	2.08	0.54
1:C:296:PHE:CE1	1:C:335:ILE:HD13	2.43	0.54
4:F:147:TRP:HB2	4:F:169:LEU:HD11	1.90	0.54
2:B:136:GLN:HA	2:B:167:ASN:O	2.06	0.54

Continued on next page...

Continued from previous page...

Atom-1	Atom-2	Interatomic distance (Å)	Clash overlap (Å)
2:B:36:TYR:CD1	2:B:46:LEU:HD21	2.43	0.54
2:B:345:GLU:OE1	2:B:345:GLU:N	2.35	0.54
1:A:28:HIS:O	1:A:36:MET:HE3	2.09	0.53
1:A:214:ARG:HG2	1:A:219:ILE:O	2.08	0.53
2:D:325:MET:HE2	2:D:355:VAL:HG21	1.89	0.53
1:A:233:GLN:HG3	1:A:368:LEU:CD1	2.39	0.53
4:F:147:TRP:HB2	4:F:169:LEU:CD1	2.39	0.53
2:B:42:LEU:H	2:B:42:LEU:HD12	1.72	0.53
1:C:230:LEU:O	1:C:234:ILE:HD12	2.08	0.53
2:B:333:LEU:O	2:B:337:ASN:ND2	2.42	0.53
2:D:244:PHE:CE1	2:D:358:ILE:HD12	2.44	0.53
4:F:296:MET:SD	4:F:380:HIS:HB2	2.49	0.53
2:D:171:VAL:HA	2:D:204:ILE:O	2.09	0.52
2:D:152:LEU:O	2:D:156:LYS:HG2	2.09	0.52
1:C:248:LEU:HD12	1:C:357:TYR:OH	2.09	0.52
1:A:88:HIS:CD2	1:A:91:GLN:HG3	2.45	0.52
2:D:2:ARG:HB2	2:D:133:GLN:HE21	1.74	0.52
2:D:397:ALA:HA	2:D:400:ARG:NH1	2.25	0.52
2:B:106:GLY:O	2:B:111:GLY:HA3	2.09	0.52
1:C:286:LEU:HA	1:C:290:GLU:OE1	2.10	0.52
4:F:236:LYS:HB3	4:F:240:LEU:CD1	2.37	0.51
2:D:69:ASP:O	2:D:94:PHE:HA	2.10	0.51
1:A:98:ASP:HB2	5:A:501:GTP:O2G	2.11	0.51
1:A:88:HIS:HB2	1:A:89:PRO:HD2	1.92	0.51
1:A:71:GLU:HG2	1:A:72:PRO:CD	2.41	0.51
4:F:320:MET:HG3	4:F:330:ILE:HD11	1.93	0.51
1:C:312:TYR:CD1	1:C:341:ILE:HG23	2.46	0.51
2:D:402:LYS:HE2	2:D:415:GLU:OE1	2.10	0.51
2:D:21:TRP:CE3	2:D:63:PRO:HB3	2.46	0.51
4:F:219:GLY:HA3	4:F:264:PHE:CZ	2.46	0.51
1:A:166:LYS:HE2	1:A:197:HIS:O	2.11	0.50
2:D:2:ARG:HB3	2:D:133:GLN:CG	2.41	0.50
1:C:431:ASP:OD1	12:C:602:HOH:O	2.20	0.50
1:C:298:PRO:HG2	1:C:308:ARG:NH2	2.27	0.50
1:A:179:THR:HA	2:B:352:LYS:HD2	1.93	0.50
2:B:325:MET:HE2	2:B:355:VAL:CB	2.39	0.50
1:C:104:ALA:HB2	1:C:413:MET:SD	2.52	0.49
1:C:430:LYS:HE2	1:C:434:GLU:OE2	2.12	0.49
2:D:114:LEU:HD23	2:D:149:MET:HE1	1.93	0.49
4:F:200:ASP:OD1	4:F:222:ARG:HB2	2.12	0.49
4:F:216:TYR:OH	4:F:345:GLU:OE1	2.30	0.49

Continued on next page...

Continued from previous page...

Atom-1	Atom-2	Interatomic distance (Å)	Clash overlap (Å)
2:B:318:ILE:N	2:B:318:ILE:HD12	2.27	0.49
3:E:45:PRO:HA	3:E:49:GLU:OE1	2.13	0.49
4:F:201:ILE:HG12	4:F:221:LEU:HG	1.94	0.49
2:B:223:THR:O	2:B:227:LEU:HD13	2.12	0.49
2:D:12:CYS:HB2	8:D:501:GDP:C8	2.47	0.49
1:A:93:ILE:HD11	1:A:121:ARG:HG3	1.95	0.49
2:B:123:ARG:O	2:B:127:GLU:HG3	2.13	0.49
2:B:200:GLU:OE2	2:B:255:LEU:HG	2.13	0.49
1:A:188:ILE:HD12	1:A:395:PHE:HB2	1.93	0.49
2:D:327:GLU:O	2:D:331:GLN:HG2	2.12	0.49
1:C:151:SER:HB2	1:C:193:THR:CG2	2.43	0.49
2:D:141:LEU:HD12	2:D:172:MET:SD	2.53	0.49
2:D:387:LEU:HD23	2:D:387:LEU:C	2.38	0.49
1:A:101:ASN:HD22	2:B:258:ASN:HD21	1.61	0.48
2:B:6:HIS:CD2	2:B:21:TRP:HE1	2.31	0.48
2:B:323:MET:HB3	2:B:373:MET:CE	2.43	0.48
1:A:294:ALA:O	1:A:300:ASN:ND2	2.47	0.48
2:B:431:GLU:O	2:B:434:GLN:HG2	2.13	0.48
1:A:69:ASP:O	1:A:94:THR:HA	2.14	0.48
2:B:290:GLU:O	2:B:294:GLN:HG3	2.14	0.48
1:C:292:THR:HG22	1:C:335:ILE:CD1	2.43	0.48
4:F:103:THR:HG23	4:F:128:ARG:NH2	2.28	0.48
4:F:220:VAL:HG11	4:F:339:ALA:HB2	1.93	0.48
1:A:187:SER:CB	1:A:391:LEU:HD21	2.43	0.48
1:C:320:ARG:HG3	1:C:360:PRO:HG3	1.95	0.48
2:D:143:GLY:HA3	8:D:501:GDP:O3A	2.14	0.48
1:A:31:GLN:HB2	1:A:33:ASP:OD1	2.14	0.47
4:F:10:ASN:CB	4:F:44:ARG:HH22	2.27	0.47
1:A:151:SER:HB2	1:A:193:THR:OG1	2.14	0.47
2:B:42:LEU:HB2	2:B:358:ILE:HD11	1.96	0.47
2:B:334:ASN:OD1	2:B:338:LYS:HD3	2.13	0.47
1:A:21:TRP:CZ3	1:A:63:PRO:HB3	2.50	0.47
2:D:177:VAL:HG21	2:D:206:ASN:HB3	1.97	0.47
4:F:198:LYS:HE3	4:F:320:MET:HE1	1.95	0.47
1:A:351:PHE:HE1	3:E:24:LEU:HD11	1.79	0.47
1:C:296:PHE:CD1	1:C:335:ILE:HD13	2.49	0.47
2:D:67:LEU:N	2:D:67:LEU:HD12	2.29	0.47
2:D:318:ILE:N	2:D:318:ILE:HD12	2.29	0.47
4:F:217:ARG:HG3	4:F:218:GLU:HG2	1.96	0.47
1:C:270:ALA:C	1:C:302:MET:HG2	2.40	0.47
1:A:22:GLU:HG3	1:A:83:TYR:CE1	2.51	0.46

Continued on next page...

Continued from previous page...

Atom-1	Atom-2	Interatomic distance (Å)	Clash overlap (Å)
2:D:31:ASP:HB2	2:D:32:PRO:HD2	1.97	0.46
4:F:242:ASN:HD22	4:F:245:ILE:CD1	2.28	0.46
4:F:331:GLU:OE2	11:F:401:ACP:O3G	2.33	0.46
1:A:233:GLN:HG3	1:A:368:LEU:HD12	1.96	0.46
1:C:172:TYR:HB3	1:C:205:ASP:HA	1.98	0.46
2:D:286:LEU:HD23	2:D:291:LEU:HD13	1.98	0.46
4:F:320:MET:CG	4:F:330:ILE:HD11	2.45	0.46
1:A:193:THR:HG23	12:A:633:HOH:O	2.16	0.46
1:C:11:GLN:HE22	2:D:247:GLN:NE2	2.14	0.46
2:D:6:HIS:CD2	2:D:21:TRP:HE1	2.33	0.46
1:A:71:GLU:HG2	1:A:72:PRO:N	2.31	0.46
1:C:163:LYS:HG3	3:E:90:ASN:OD1	2.15	0.46
1:A:178:SER:OG	1:A:183:GLU:OE1	2.14	0.46
2:D:106:GLY:O	2:D:111:GLY:HA3	2.16	0.46
1:C:21:TRP:CZ3	1:C:63:PRO:HB3	2.51	0.46
2:B:241:CYS:O	2:B:250:ALA:HB2	2.16	0.46
4:F:202:ARG:HB3	4:F:220:VAL:HG23	1.98	0.46
2:B:21:TRP:CE3	2:B:63:PRO:HB3	2.51	0.45
9:B:504:MES:H51	9:B:504:MES:H81	1.59	0.45
1:C:209:ILE:CD1	1:C:302:MET:HE3	2.42	0.45
2:B:204:ILE:HD13	2:B:231:VAL:HG13	1.98	0.45
2:B:204:ILE:CG2	2:B:209:LEU:HD11	2.46	0.45
2:D:31:ASP:HB2	2:D:32:PRO:CD	2.46	0.45
4:F:87:LEU:O	4:F:88:SER:OG	2.28	0.45
1:A:241:SER:HB2	1:A:248:LEU:O	2.16	0.45
2:B:387:LEU:C	2:B:387:LEU:HD23	2.42	0.45
1:C:385:ALA:HA	1:C:388:TRP:CD1	2.52	0.45
2:D:67:LEU:HD22	2:D:92:PHE:CE2	2.51	0.45
2:B:21:TRP:CH2	2:B:52:TYR:HB3	2.52	0.45
2:B:157:ILE:CG2	2:B:166:MET:HE1	2.47	0.45
2:B:292:THR:HG22	2:B:335:VAL:HG21	1.98	0.45
2:D:46:LEU:HA	2:D:49:ILE:HB	1.98	0.45
2:D:147:SER:HB2	2:D:190:SER:OG	2.17	0.45
2:B:75:MET:HE3	2:B:92:PHE:CD2	2.51	0.44
1:C:167:LEU:HG	1:C:200:CYS:HB3	1.99	0.44
2:D:2:ARG:HB3	2:D:133:GLN:HG3	1.97	0.44
1:A:227:LEU:O	1:A:231:ILE:HG13	2.17	0.44
4:F:371:PRO:HA	4:F:372:THR:CB	2.44	0.44
1:C:28:HIS:O	1:C:36:MET:HE3	2.17	0.44
1:C:108:TYR:O	1:C:112:LYS:HG2	2.17	0.44
2:D:332:MET:O	2:D:336:GLN:HG3	2.17	0.44

Continued on next page...

Continued from previous page...

Atom-1	Atom-2	Interatomic distance (Å)	Clash overlap (Å)
1:A:265:ILE:HG21	1:A:313:MET:HE1	1.99	0.44
2:B:88:ARG:HH11	2:B:90:ASP:HB2	1.81	0.44
2:B:295:MET:HG2	2:B:377:PHE:HB2	2.00	0.44
4:F:280:GLU:OE1	4:F:284:LEU:HD23	2.18	0.44
1:A:188:ILE:HD12	1:A:395:PHE:CD2	2.53	0.44
1:C:344:VAL:HG21	1:C:346:TRP:CE2	2.53	0.44
2:D:286:LEU:HD12	2:D:290:GLU:OE1	2.18	0.44
2:B:31:ASP:HB2	2:B:32:PRO:CD	2.48	0.44
2:B:40:SER:OG	2:B:42:LEU:HD13	2.17	0.44
2:B:138:THR:HG21	2:B:235:MET:HE1	2.00	0.43
1:C:7:ILE:HG21	1:C:153:LEU:HD21	2.00	0.43
2:B:42:LEU:HD12	2:B:42:LEU:N	2.32	0.43
4:F:102:PRO:HB2	4:F:104:ASN:OD1	2.17	0.43
4:F:69:ASP:OD1	4:F:69:ASP:N	2.52	0.43
2:B:7:ILE:O	2:B:137:LEU:HA	2.19	0.43
2:B:276:THR:HG21	2:B:282:GLN:HA	2.01	0.43
4:F:205:VAL:HG21	4:F:291:ILE:HD13	2.00	0.43
1:A:66:VAL:HG23	1:A:125:LEU:HD12	2.00	0.43
1:C:107:HIS:HD2	1:C:151:SER:OG	2.02	0.43
2:B:301:MET:HE1	2:B:312:TYR:OH	2.19	0.43
1:A:217:LEU:HD21	1:A:368:LEU:HD23	2.01	0.42
1:A:223:THR:O	1:A:227:LEU:HG	2.19	0.42
2:B:244:PHE:CE1	2:B:358:ILE:HD12	2.54	0.42
1:C:88:HIS:HE1	1:C:90:GLU:HG3	1.84	0.42
4:F:14:TYR:CD1	4:F:41:LEU:HD22	2.54	0.42
4:F:37:PHE:CZ	4:F:40:MET:HE3	2.54	0.42
2:B:67:LEU:N	2:B:67:LEU:HD12	2.35	0.42
2:B:104:ALA:HB2	2:B:413:MET:SD	2.58	0.42
2:D:1:MET:CG	2:D:50:ASN:HB2	2.48	0.42
4:F:131:PHE:CE1	4:F:182:ILE:HG21	2.55	0.42
4:F:214:TYR:HB3	4:F:375:PHE:HB3	2.01	0.42
1:C:117:LEU:HD11	1:C:121:ARG:CZ	2.50	0.42
1:C:174:ALA:CB	1:C:207:GLU:HB2	2.50	0.42
2:B:75:MET:HE3	2:B:92:PHE:HD2	1.85	0.42
2:B:296:PHE:CZ	2:B:332:MET:HE1	2.54	0.42
1:C:93:ILE:CD1	1:C:121:ARG:HG3	2.49	0.42
2:D:146:GLY:O	2:D:150:GLY:HA3	2.19	0.42
1:A:25:CYS:SG	1:A:86:LEU:HD11	2.60	0.42
1:A:136:LEU:HD21	1:A:252:LEU:HD21	2.00	0.42
1:A:141:PHE:CE1	1:A:170:SER:HB3	2.54	0.42
2:B:46:LEU:HA	2:B:49:ILE:HB	2.02	0.42

Continued on next page...

Continued from previous page...

Atom-1	Atom-2	Interatomic distance (Å)	Clash overlap (Å)
4:F:191:LEU:HD13	4:F:196:HIS:CD2	2.55	0.42
2:D:18:ALA:O	2:D:22:GLU:HG3	2.20	0.41
3:E:101:LEU:O	3:E:105:MET:HG2	2.20	0.41
2:B:16:ILE:HD13	2:B:231:VAL:HG11	2.02	0.41
1:C:66:VAL:HG12	1:C:68:VAL:HG23	2.01	0.41
2:D:20:PHE:CD1	2:D:235:MET:HE2	2.56	0.41
4:F:202:ARG:HB3	4:F:220:VAL:CG2	2.50	0.41
1:A:75:ILE:HD12	1:A:94:THR:HG22	2.02	0.41
2:B:169:PHE:HE2	2:B:238:VAL:HG21	1.86	0.41
2:D:1:MET:CE	2:D:50:ASN:HB2	2.46	0.41
3:E:44:ASP:OD2	12:E:201:HOH:O	2.22	0.41
1:A:55:GLU:HA	1:A:60:LYS:O	2.21	0.41
2:B:370:GLY:O	2:B:371:LEU:HD23	2.21	0.41
2:B:402:LYS:HB3	2:B:405:LEU:HD12	2.03	0.41
4:F:3:THR:HA	4:F:28:LYS:O	2.20	0.41
4:F:101:TYR:CD2	4:F:179:VAL:HG22	2.56	0.41
1:A:187:SER:HB3	1:A:391:LEU:HD21	2.03	0.40
1:A:320:ARG:HD2	12:A:623:HOH:O	2.20	0.40
1:A:335:ILE:CG2	1:A:339:ARG:HG3	2.43	0.40
1:A:348:PRO:HG3	3:E:27:PRO:HD3	2.03	0.40
4:F:3:THR:OG1	4:F:37:PHE:HA	2.21	0.40
1:A:100:ALA:CB	2:B:253[B]:ARG:HG2	2.51	0.40
4:F:146:VAL:HG22	4:F:164:SER:HB3	2.02	0.40
2:D:187:ALA:O	2:D:191:VAL:HG23	2.21	0.40
1:C:112:LYS:NZ	1:C:113:GLU:OE2	2.55	0.40
1:C:233:GLN:HG3	1:C:368:LEU:CD1	2.51	0.40
2:D:392:SER:O	2:D:396:THR:HG22	2.22	0.40
3:E:72:LEU:O	3:E:76:ARG:HG2	2.22	0.40
1:A:188:ILE:HD11	1:A:392:ASP:HA	2.03	0.40
2:B:332:MET:O	2:B:336:GLN:HG3	2.21	0.40
2:D:241:CYS:HB3	2:D:249:ASN:O	2.22	0.40
4:F:197:ARG:HB2	4:F:224:SER:O	2.21	0.40
4:F:240:LEU:HD12	4:F:240:LEU:N	2.36	0.40

There are no symmetry-related clashes.

5.3 Torsion angles [i](#)

5.3.1 Protein backbone [i](#)

In the following table, the Percentiles column shows the percent Ramachandran outliers of the chain as a percentile score with respect to all X-ray entries followed by that with respect to entries of similar resolution.

The Analysed column shows the number of residues for which the backbone conformation was analysed, and the total number of residues.

Mol	Chain	Analysed	Favoured	Allowed	Outliers	Percentiles	
1	A	436/451 (97%)	428 (98%)	7 (2%)	1 (0%)	43	37
1	C	439/451 (97%)	430 (98%)	9 (2%)	0	100	100
2	B	417/445 (94%)	406 (97%)	9 (2%)	2 (0%)	24	16
2	D	423/445 (95%)	411 (97%)	12 (3%)	0	100	100
3	E	119/143 (83%)	117 (98%)	2 (2%)	0	100	100
4	F	344/384 (90%)	333 (97%)	11 (3%)	0	100	100
All	All	2178/2319 (94%)	2125 (98%)	50 (2%)	3 (0%)	48	43

All (3) Ramachandran outliers are listed below:

Mol	Chain	Res	Type
1	A	282	TYR
2	B	251	ASP
2	B	82	PRO

5.3.2 Protein sidechains [i](#)

In the following table, the Percentiles column shows the percent sidechain outliers of the chain as a percentile score with respect to all X-ray entries followed by that with respect to entries of similar resolution.

The Analysed column shows the number of residues for which the sidechain conformation was analysed, and the total number of residues.

Mol	Chain	Analysed	Rotameric	Outliers	Percentiles	
1	A	369/379 (97%)	363 (98%)	6 (2%)	55	56
1	C	372/379 (98%)	370 (100%)	2 (0%)	81	85
2	B	367/383 (96%)	366 (100%)	1 (0%)	86	90
2	D	368/383 (96%)	366 (100%)	2 (0%)	81	85

Continued on next page...

Continued from previous page...

Mol	Chain	Analysed	Rotameric	Outliers	Percentiles	
3	E	110/127 (87%)	109 (99%)	1 (1%)	70	75
4	F	315/342 (92%)	314 (100%)	1 (0%)	86	90
All	All	1901/1993 (95%)	1888 (99%)	13 (1%)	76	80

All (13) residues with a non-rotameric sidechain are listed below:

Mol	Chain	Res	Type
1	A	71	GLU
1	A	282	TYR
1	A	284	GLU
1	A	300	ASN
1	A	316	CYS
1	A	381	THR
2	B	167	ASN
1	C	361	THR
1	C	391	LEU
2	D	200	GLU
2	D	229	HIS
3	E	15	THR
4	F	257	GLU

Sometimes sidechains can be flipped to improve hydrogen bonding and reduce clashes. All (24) such sidechains are listed below:

Mol	Chain	Res	Type
1	A	11	GLN
1	A	88	HIS
1	A	101	ASN
1	A	301	GLN
1	A	309	HIS
1	A	406	HIS
2	B	15	GLN
2	B	192	HIS
2	B	282	GLN
2	B	294	GLN
2	B	434	GLN
1	C	11	GLN
2	D	167	ASN
2	D	294	GLN
2	D	300	ASN
2	D	394	GLN

Continued on next page...

Continued from previous page...

Mol	Chain	Res	Type
3	E	71	HIS
3	E	103	GLN
3	E	115	HIS
3	E	136	ASN
4	F	136	ASN
4	F	196	HIS
4	F	269	GLN
4	F	306	HIS

5.3.3 RNA [i](#)

There are no RNA molecules in this entry.

5.4 Non-standard residues in protein, DNA, RNA chains [i](#)

There are no non-standard protein/DNA/RNA residues in this entry.

5.5 Carbohydrates [i](#)

There are no oligosaccharides in this entry.

5.6 Ligand geometry [i](#)

Of 16 ligands modelled in this entry, 9 are monoatomic - leaving 7 for Mogul analysis.

In the following table, the Counts columns list the number of bonds (or angles) for which Mogul statistics could be retrieved, the number of bonds (or angles) that are observed in the model and the number of bonds (or angles) that are defined in the Chemical Component Dictionary. The Link column lists molecule types, if any, to which the group is linked. The Z score for a bond length (or angle) is the number of standard deviations the observed value is removed from the expected value. A bond length (or angle) with $|Z| > 2$ is considered an outlier worth inspection. RMSZ is the root-mean-square of all Z scores of the bond lengths (or angles).

Mol	Type	Chain	Res	Link	Bond lengths			Bond angles		
					Counts	RMSZ	# Z > 2	Counts	RMSZ	# Z > 2
11	ACP	F	401	6	31,33,33	1.68	9 (29%)	47,52,52	1.87	10 (21%)
9	MES	B	504	-	12,12,12	2.30	1 (8%)	15,16,16	1.89	5 (33%)
5	GTP	A	501	6	33,34,34	0.95	2 (6%)	50,54,54	1.49	8 (16%)
8	GDP	B	501	6	29,30,30	1.14	3 (10%)	45,47,47	1.72	6 (13%)
10	HR5	C	504	-	16,16,16	1.48	3 (18%)	21,22,22	3.46	11 (52%)

Mol	Type	Chain	Res	Link	Bond lengths			Bond angles		
					Counts	RMSZ	# Z > 2	Counts	RMSZ	# Z > 2
8	GDP	D	501	6	29,30,30	1.18	4 (13%)	45,47,47	1.71	6 (13%)
5	GTP	C	501	6	33,34,34	0.98	3 (9%)	50,54,54	1.50	8 (16%)

In the following table, the Chirals column lists the number of chiral outliers, the number of chiral centers analysed, the number of these observed in the model and the number defined in the Chemical Component Dictionary. Similar counts are reported in the Torsion and Rings columns. '-' means no outliers of that kind were identified.

Mol	Type	Chain	Res	Link	Chirals	Torsions	Rings
11	ACP	F	401	6	-	9/19/38/38	0/3/3/3
9	MES	B	504	-	-	4/6/14/14	0/1/1/1
5	GTP	A	501	6	-	7/22/38/38	0/3/3/3
8	GDP	B	501	6	-	3/16/32/32	0/3/3/3
10	HR5	C	504	-	-	0/9/15/15	0/2/2/2
8	GDP	D	501	6	-	4/16/32/32	0/3/3/3
5	GTP	C	501	6	-	9/22/38/38	0/3/3/3

All (25) bond length outliers are listed below:

Mol	Chain	Res	Type	Atoms	Z	Observed(Å)	Ideal(Å)
9	B	504	MES	C8-S	-7.70	1.66	1.77
11	F	401	ACP	C5-C4	4.79	1.47	1.39
10	C	504	HR5	C5-N2	3.35	1.39	1.33
10	C	504	HR5	C3-N	3.26	1.37	1.32
8	D	501	GDP	C5-C4	3.11	1.47	1.38
8	B	501	GDP	C5-C4	3.04	1.47	1.38
11	F	401	ACP	PG-O3G	3.00	1.61	1.55
11	F	401	ACP	PG-O2G	2.94	1.61	1.55
11	F	401	ACP	PB-O3A	2.79	1.61	1.58
11	F	401	ACP	C5-C6	2.69	1.48	1.41
10	C	504	HR5	N1-N	2.53	1.40	1.36
5	C	501	GTP	PA-O3A	2.33	1.62	1.59
8	D	501	GDP	C6-N1	-2.31	1.34	1.38
11	F	401	ACP	C8-N7	2.30	1.36	1.31
5	A	501	GTP	PA-O3A	2.25	1.61	1.59
8	D	501	GDP	PA-O3A	2.24	1.61	1.59
11	F	401	ACP	C5-N7	-2.22	1.35	1.39
8	B	501	GDP	C6-N1	-2.22	1.34	1.38
5	C	501	GTP	C2-N3	2.20	1.38	1.33
11	F	401	ACP	PA-O3A	2.13	1.61	1.59

Continued on next page...

Continued from previous page...

Mol	Chain	Res	Type	Atoms	Z	Observed(Å)	Ideal(Å)
11	F	401	ACP	PB-O2B	2.12	1.61	1.56
5	C	501	GTP	PB-O3A	2.12	1.61	1.59
5	A	501	GTP	C2-N3	2.07	1.38	1.33
8	B	501	GDP	C5-N7	-2.06	1.34	1.39
8	D	501	GDP	C5-N7	-2.04	1.35	1.39

All (54) bond angle outliers are listed below:

Mol	Chain	Res	Type	Atoms	Z	Observed(°)	Ideal(°)
10	C	504	HR5	C1-N1-N	-12.56	108.47	112.91
8	D	501	GDP	C5-C4-N3	-5.92	118.97	128.39
11	F	401	ACP	C5-C4-N3	-5.79	118.75	126.72
8	B	501	GDP	C5-C4-N3	-5.75	119.25	128.39
8	B	501	GDP	C2-N3-C4	5.03	120.97	112.30
8	D	501	GDP	C2-N3-C4	4.96	120.84	112.30
5	C	501	GTP	C5-C4-N3	-4.95	120.51	128.39
5	A	501	GTP	C5-C4-N3	-4.77	120.80	128.39
11	F	401	ACP	N3-C4-N9	4.65	135.08	127.17
5	A	501	GTP	C2-N3-C4	4.50	120.04	112.30
5	C	501	GTP	C2-N3-C4	4.43	119.92	112.30
8	D	501	GDP	N9-C4-N3	4.37	134.69	125.95
8	B	501	GDP	N9-C4-N3	4.36	134.66	125.95
10	C	504	HR5	C2-C1-N1	3.98	107.97	105.78
11	F	401	ACP	PB-O3A-PA	-3.95	119.49	132.37
9	B	504	MES	C5-N4-C3	3.83	117.09	108.84
11	F	401	ACP	C2-N3-C4	3.64	120.73	111.83
10	C	504	HR5	O-C5-N2	-3.64	116.77	123.35
11	F	401	ACP	C4-C5-N7	-3.45	106.64	110.58
8	B	501	GDP	C6-C5-N7	3.35	136.38	130.29
8	D	501	GDP	C6-C5-N7	3.35	136.38	130.29
9	B	504	MES	C6-C5-N4	-3.24	105.20	110.12
10	C	504	HR5	C3-C2-C1	3.22	107.43	104.87
5	C	501	GTP	N9-C4-N3	3.20	132.35	125.95
11	F	401	ACP	N3-C2-N1	-3.17	123.79	128.58
10	C	504	HR5	C2-C3-N	-3.15	108.54	112.45
5	A	501	GTP	N9-C4-N3	2.91	131.77	125.95
5	A	501	GTP	C2-N1-C6	-2.80	120.03	125.11
5	C	501	GTP	C2-N1-C6	-2.75	120.12	125.11
11	F	401	ACP	C4-N9-C8	2.69	108.57	105.74
10	C	504	HR5	C3-N-N1	2.65	107.59	105.06
5	A	501	GTP	N9-C8-N7	-2.61	108.56	113.40
5	C	501	GTP	N9-C8-N7	-2.60	108.58	113.40

Continued on next page...

Continued from previous page...

Mol	Chain	Res	Type	Atoms	Z	Observed(°)	Ideal(°)
8	D	501	GDP	C4-C5-N7	-2.58	106.57	110.67
11	F	401	ACP	C5-N7-C8	2.55	107.46	103.45
8	B	501	GDP	O6-C6-C5	-2.47	120.00	126.53
10	C	504	HR5	C2-C5-N2	2.46	121.92	116.67
11	F	401	ACP	C3'-C2'-C1'	2.45	106.10	101.46
5	C	501	GTP	C8-N7-C5	2.43	108.58	104.26
5	A	501	GTP	C8-N7-C5	2.42	108.57	104.26
5	A	501	GTP	C5-C6-N1	2.41	119.39	113.25
5	C	501	GTP	C5-C6-N1	2.39	119.33	113.25
5	A	501	GTP	O6-C6-C5	-2.38	120.25	126.53
8	B	501	GDP	C4-C5-N7	-2.36	106.94	110.67
10	C	504	HR5	C-C1-N1	-2.32	119.30	122.97
5	C	501	GTP	O6-C6-C5	-2.31	120.44	126.53
9	B	504	MES	O1S-S-C8	2.30	110.21	106.73
9	B	504	MES	C7-N4-C5	2.15	116.98	111.24
8	D	501	GDP	O6-C6-C5	-2.11	120.96	126.53
10	C	504	HR5	C3-C2-C5	-2.11	123.33	129.45
9	B	504	MES	O2S-S-C8	2.11	109.91	106.73
10	C	504	HR5	C8-C7-C6	-2.05	114.22	118.95
11	F	401	ACP	C6-C5-N7	2.04	136.03	132.09
10	C	504	HR5	C4-N1-C1	2.02	129.94	128.09

There are no chirality outliers.

All (36) torsion outliers are listed below:

Mol	Chain	Res	Type	Atoms
5	A	501	GTP	C5'-O5'-PA-O3A
5	A	501	GTP	C5'-O5'-PA-O1A
5	A	501	GTP	C5'-O5'-PA-O2A
5	C	501	GTP	C5'-O5'-PA-O3A
5	C	501	GTP	C5'-O5'-PA-O1A
5	C	501	GTP	C5'-O5'-PA-O2A
8	B	501	GDP	C5'-O5'-PA-O3A
8	B	501	GDP	C5'-O5'-PA-O1A
8	B	501	GDP	C5'-O5'-PA-O2A
8	D	501	GDP	PA-O3A-PB-O3B
8	D	501	GDP	C5'-O5'-PA-O3A
8	D	501	GDP	C5'-O5'-PA-O1A
8	D	501	GDP	C5'-O5'-PA-O2A
9	B	504	MES	C8-C7-N4-C5
9	B	504	MES	C7-C8-S-O2S
9	B	504	MES	C7-C8-S-O3S

Continued on next page...

Continued from previous page...

Mol	Chain	Res	Type	Atoms
11	F	401	ACP	PG-C3B-PB-O1B
11	F	401	ACP	PG-C3B-PB-O2B
11	F	401	ACP	PG-C3B-PB-O3A
11	F	401	ACP	O4'-C4'-C5'-O5'
11	F	401	ACP	C3'-C4'-C5'-O5'
9	B	504	MES	C7-C8-S-O1S
11	F	401	ACP	PB-C3B-PG-O2G
11	F	401	ACP	PB-C3B-PG-O3G
5	C	501	GTP	PB-O3A-PA-O2A
5	C	501	GTP	PB-O3B-PG-O1G
5	A	501	GTP	C4'-C5'-O5'-PA
5	A	501	GTP	PB-O3A-PA-O2A
5	A	501	GTP	PB-O3B-PG-O2G
5	C	501	GTP	PB-O3B-PG-O2G
5	C	501	GTP	PB-O3B-PG-O3G
5	C	501	GTP	C4'-C5'-O5'-PA
11	F	401	ACP	PB-C3B-PG-O1G
11	F	401	ACP	PB-O3A-PA-O2A
5	A	501	GTP	PB-O3A-PA-O1A
5	C	501	GTP	PB-O3A-PA-O1A

There are no ring outliers.

4 monomers are involved in 8 short contacts:

Mol	Chain	Res	Type	Clashes	Symm-Clashes
11	F	401	ACP	3	0
9	B	504	MES	2	0
5	A	501	GTP	1	0
8	D	501	GDP	2	0

The following is a two-dimensional graphical depiction of Mogul quality analysis of bond lengths, bond angles, torsion angles, and ring geometry for all instances of the Ligand of Interest. In addition, ligands with molecular weight > 250 and outliers as shown on the validation Tables will also be included. For torsion angles, if less than 5% of the Mogul distribution of torsion angles is within 10 degrees of the torsion angle in question, then that torsion angle is considered an outlier. Any bond that is central to one or more torsion angles identified as an outlier by Mogul will be highlighted in the graph. For rings, the root-mean-square deviation (RMSD) between the ring in question and similar rings identified by Mogul is calculated over all ring torsion angles. If the average RMSD is greater than 60 degrees and the minimal RMSD between the ring in question and any Mogul-identified rings is also greater than 60 degrees, then that ring is considered an outlier. The outliers are highlighted in purple. The color gray indicates Mogul did not find sufficient equivalents in the CSD to analyse the geometry.

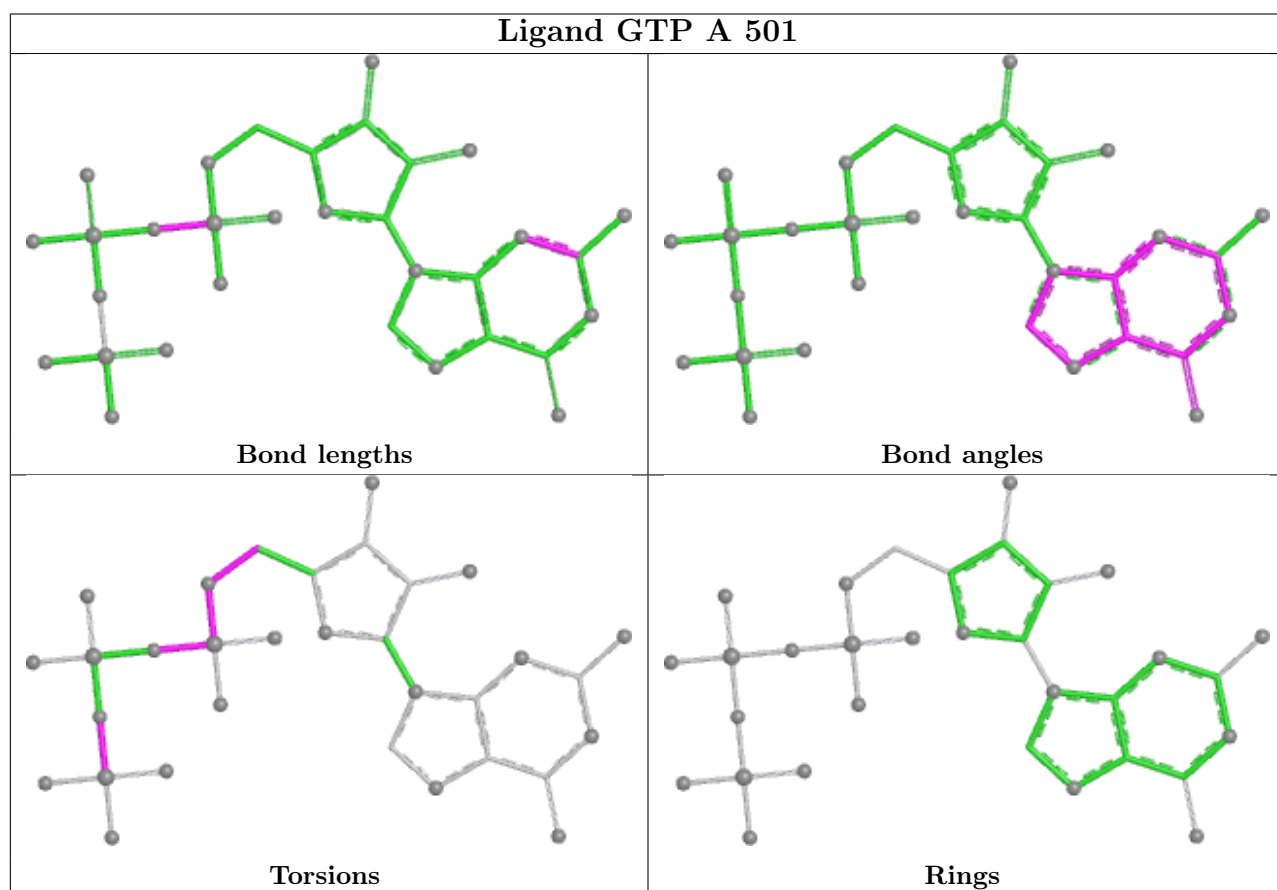
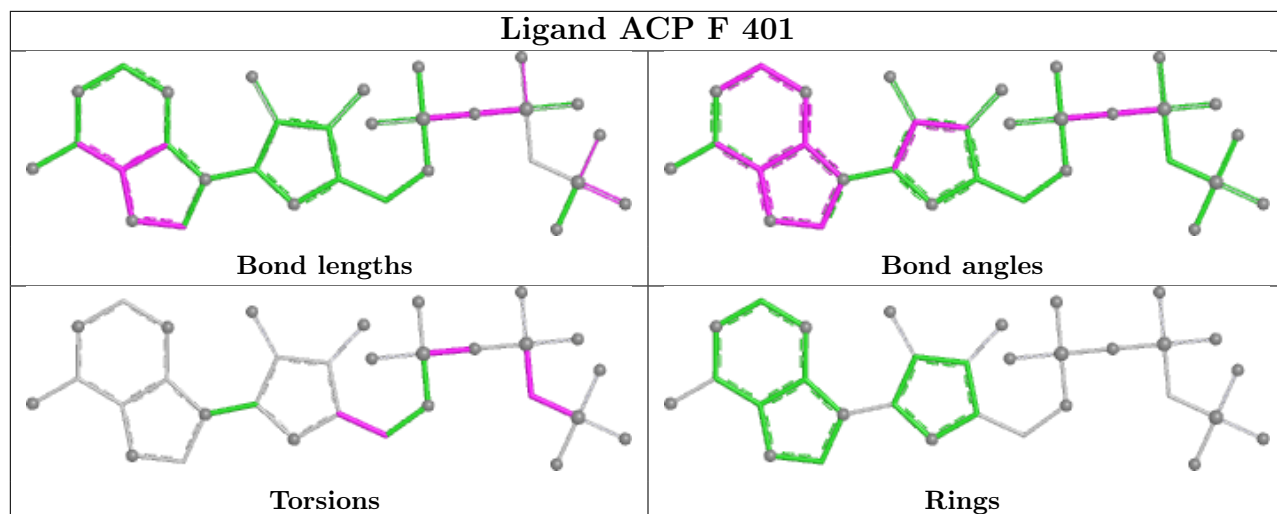

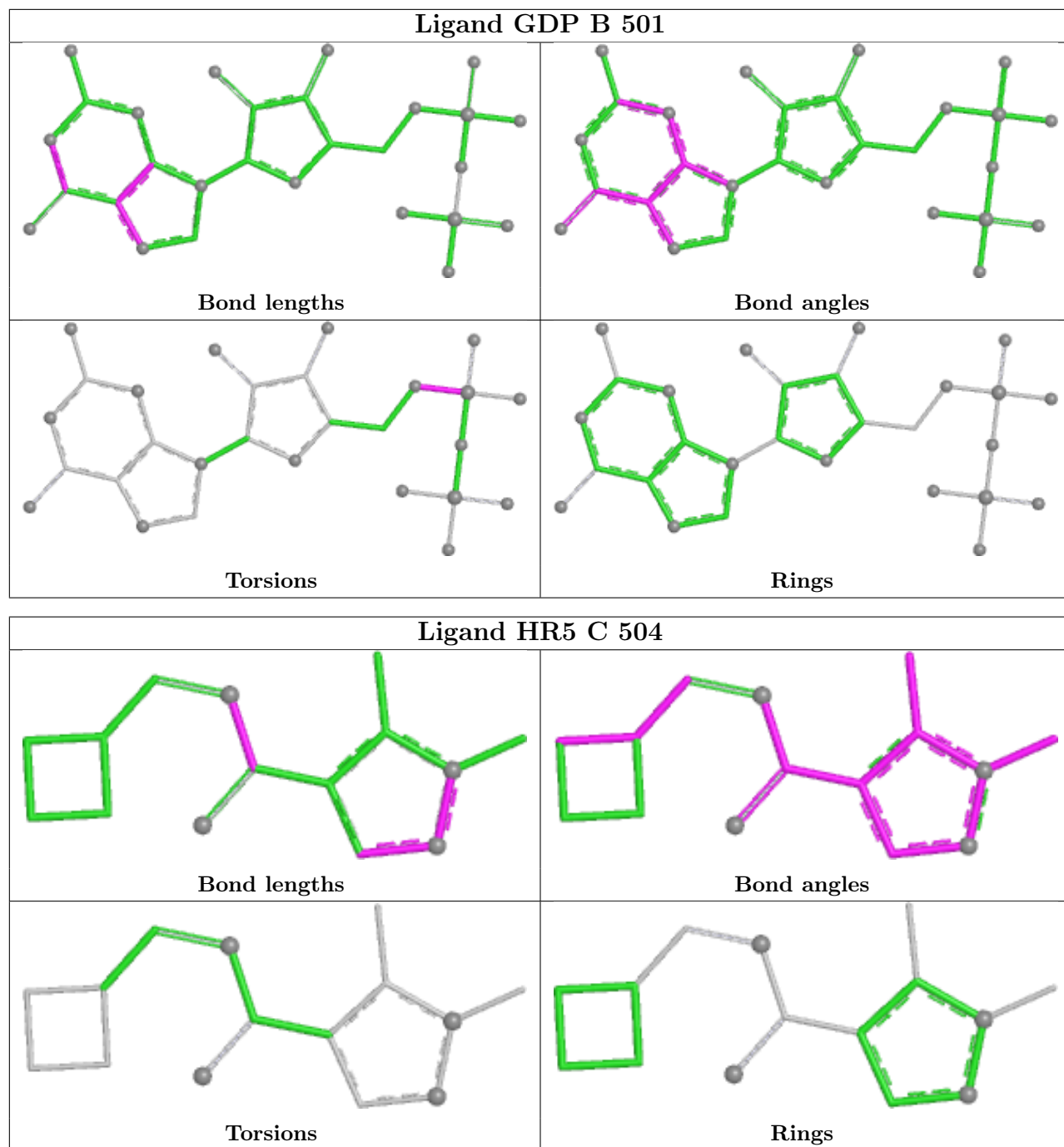

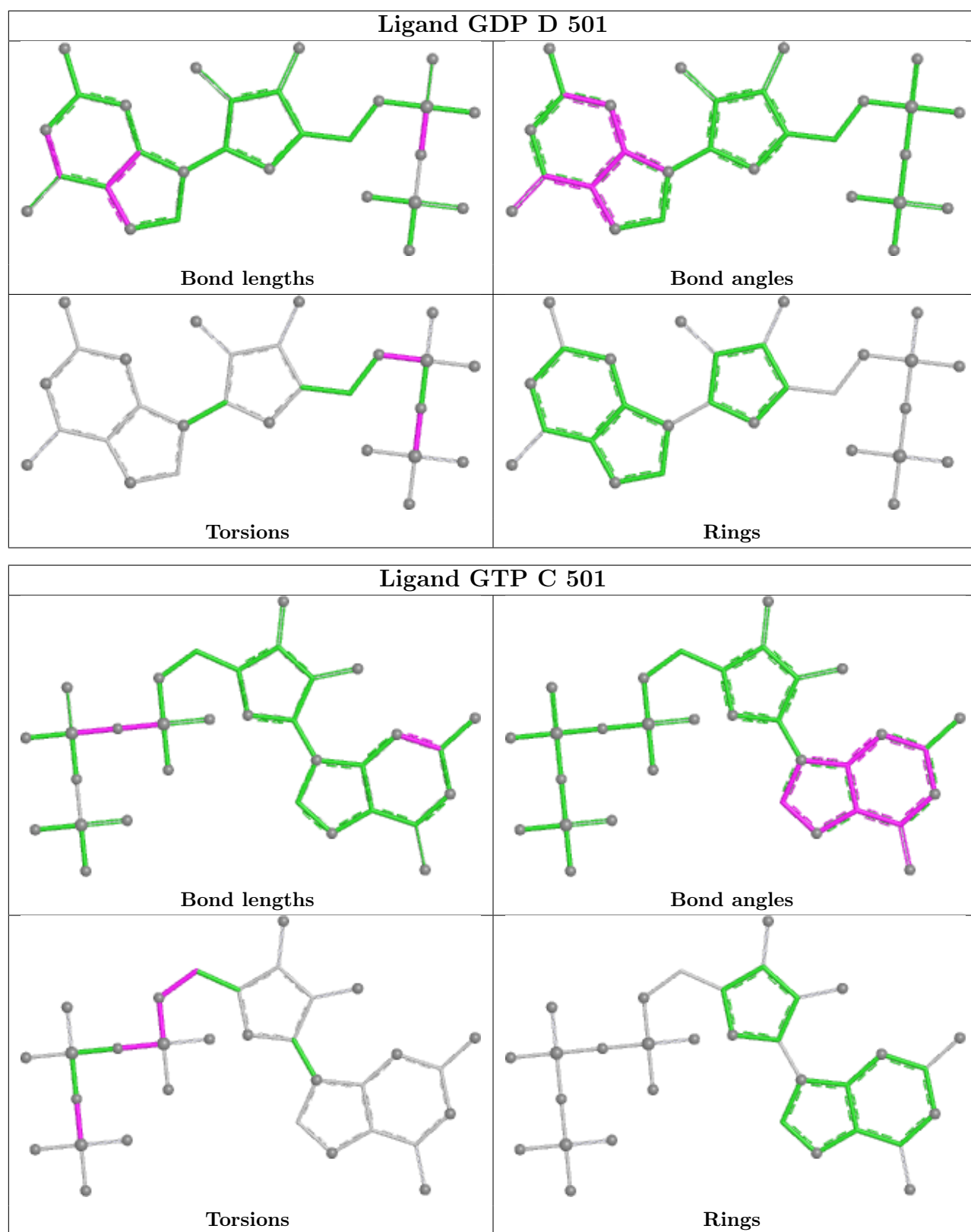

5.7 Other polymers [i](#)

There are no such residues in this entry.

5.8 Polymer linkage issues

There are no chain breaks in this entry.

6 Fit of model and data [i](#)

6.1 Protein, DNA and RNA chains [i](#)

In the following table, the column labelled ‘#RSRZ > 2’ contains the number (and percentage) of RSRZ outliers, followed by percent RSRZ outliers for the chain as percentile scores relative to all X-ray entries and entries of similar resolution. The OWAB column contains the minimum, median, 95th percentile and maximum values of the occupancy-weighted average B-factor per residue. The column labelled ‘Q < 0.9’ lists the number of (and percentage) of residues with an average occupancy less than 0.9.

Mol	Chain	Analysed	<RSRZ>	#RSRZ>2	OWAB(Å ²)	Q<0.9
1	A	438/451 (97%)	0.51	26 (5%) 28 28	41, 56, 87, 160	0
1	C	440/451 (97%)	0.20	22 (5%) 34 34	21, 46, 65, 101	1 (0%)
2	B	422/445 (94%)	0.72	36 (8%) 16 17	29, 57, 100, 137	2 (0%)
2	D	427/445 (95%)	0.58	27 (6%) 26 26	40, 62, 92, 139	4 (0%)
3	E	123/143 (86%)	0.88	11 (8%) 15 15	43, 64, 108, 134	0
4	F	352/384 (91%)	1.03	39 (11%) 10 10	52, 83, 149, 177	0
All	All	2202/2319 (94%)	0.60	161 (7%) 21 21	21, 58, 110, 177	7 (0%)

All (161) RSRZ outliers are listed below:

Mol	Chain	Res	Type	RSRZ
2	B	246	GLY	5.4
2	B	333	LEU	5.3
2	B	250	ALA	5.3
3	E	143	ALA	4.8
4	F	159	GLY	4.7
4	F	240	LEU	4.7
2	D	277	SER	4.6
4	F	155	ALA	4.5
2	D	276	THR	4.3
2	D	279	GLY	4.3
1	C	350	GLY	4.1
2	D	407	TRP	4.1
1	C	357	TYR	4.1
2	B	335	VAL	4.0
4	F	371	PRO	3.9
2	B	340	SER	3.9
2	B	83	PHE	3.9
2	D	404	PHE	3.8
2	B	241	CYS	3.8

Continued on next page...

Continued from previous page...

Mol	Chain	Res	Type	RSRZ
4	F	186	LEU	3.7
1	C	440	VAL	3.7
2	B	339	ASN	3.7
4	F	125	THR	3.7
3	E	6	MET	3.7
4	F	90	SER	3.7
2	B	275	LEU	3.6
2	D	1	MET	3.6
2	B	1	MET	3.5
1	A	337	THR	3.5
4	F	105	LEU	3.5
2	B	285	ALA	3.4
1	A	179	THR	3.4
1	A	282	TYR	3.4
1	C	284	GLU	3.3
2	B	255	LEU	3.2
4	F	160	ILE	3.2
2	D	272	PHE	3.2
2	B	303	ALA	3.1
2	B	284	ARG	3.1
2	B	57	THR	3.0
3	E	26	PRO	3.0
1	A	346	TRP	3.0
2	B	286	LEU	3.0
2	B	276	THR	3.0
4	F	153	ALA	3.0
4	F	231	ALA	3.0
1	C	308	ARG	2.9
2	D	278	ARG	2.9
4	F	181	VAL	2.9
2	D	83	PHE	2.9
2	D	56	ALA	2.9
4	F	161	LEU	2.9
2	D	247	GLN	2.8
2	D	241	CYS	2.8
4	F	382	HIS	2.8
1	C	335	ILE	2.8
2	B	325	MET	2.8
2	D	248	LEU	2.8
1	C	309	HIS	2.7
3	E	23	ILE	2.7
2	D	57	THR	2.7

Continued on next page...

Continued from previous page...

Mol	Chain	Res	Type	RSRZ
2	B	328	VAL	2.7
4	F	362	ALA	2.7
1	A	438	ASP	2.7
2	D	285	ALA	2.6
2	B	400	ARG	2.6
2	D	280	SER	2.6
4	F	330	ILE	2.6
1	A	281	ALA	2.6
1	A	381	THR	2.6
2	D	82	PRO	2.6
1	A	176	GLN	2.6
1	C	282	TYR	2.6
2	D	181	VAL	2.6
4	F	182	ILE	2.6
4	F	154	GLY	2.6
1	C	293	ASN	2.6
4	F	242	ASN	2.6
1	C	283	HIS	2.5
4	F	44	ARG	2.5
1	C	337	THR	2.5
1	A	285	GLN	2.5
1	C	128	GLN	2.5
1	A	437	VAL	2.5
2	B	337	ASN	2.5
1	A	284	GLU	2.5
1	C	340	SER	2.5
4	F	172	PHE	2.5
4	F	381	HIS	2.5
4	F	249	TYR	2.5
1	C	80	THR	2.5
4	F	361	LEU	2.5
1	A	219	ILE	2.5
1	C	46	ASP	2.4
1	A	262	TYR	2.4
1	A	316	CYS	2.4
3	E	45	PRO	2.4
2	B	336	GLN	2.4
2	D	2	ARG	2.4
2	B	283	TYR	2.4
4	F	379	HIS	2.4
1	C	245	ASP	2.4
2	B	251	ASP	2.3

Continued on next page...

Continued from previous page...

Mol	Chain	Res	Type	RSRZ
1	A	42	ILE	2.3
4	F	243	HIS	2.3
1	C	286	LEU	2.3
3	E	139	LEU	2.3
1	A	221	ARG	2.3
2	B	82	PRO	2.3
3	E	15	THR	2.3
2	B	167	ASN	2.3
4	F	45	ASN	2.3
2	B	42	LEU	2.3
2	B	281	GLN	2.3
1	A	293	ASN	2.3
4	F	91	CYS	2.3
2	B	435	TYR	2.3
1	A	88	HIS	2.2
1	C	341	ILE	2.2
1	A	362	VAL	2.2
2	D	195	VAL	2.2
3	E	8	VAL	2.2
2	B	305	CYS	2.2
4	F	140	GLU	2.2
4	F	244	CYS	2.2
1	C	163	LYS	2.2
2	D	317	ALA	2.2
1	A	283	HIS	2.2
3	E	24	LEU	2.2
4	F	142	ARG	2.2
3	E	22	VAL	2.1
2	D	293	GLN	2.1
4	F	306	HIS	2.1
1	C	339	ARG	2.1
4	F	46	ARG	2.1
1	C	120	ASP	2.1
1	C	218	ASP	2.1
4	F	233	PHE	2.1
2	B	2	ARG	2.1
1	A	237	SER	2.1
3	E	46	SER	2.1
1	A	37	PRO	2.1
2	D	294	GLN	2.1
2	B	378	ILE	2.1
1	A	58	ALA	2.1

Continued on next page...

Continued from previous page...

Mol	Chain	Res	Type	RSRZ
2	D	371	LEU	2.1
2	B	353	THR	2.1
1	A	335	ILE	2.1
2	B	338	LYS	2.1
2	D	355	VAL	2.1
4	F	220	VAL	2.1
4	F	344	ALA	2.1
2	D	42	LEU	2.0
2	B	90	ASP	2.0
1	A	89	PRO	2.0
2	D	117	SER	2.0
4	F	152	SER	2.0
4	F	104	ASN	2.0
1	A	342	GLN	2.0
2	B	124	LYS	2.0
4	F	334	GLY	2.0

6.2 Non-standard residues in protein, DNA, RNA chains [i](#)

There are no non-standard protein/DNA/RNA residues in this entry.

6.3 Carbohydrates [i](#)

There are no oligosaccharides in this entry.

6.4 Ligands [i](#)

In the following table, the Atoms column lists the number of modelled atoms in the group and the number defined in the chemical component dictionary. The B-factors column lists the minimum, median, 95th percentile and maximum values of B factors of atoms in the group. The column labelled 'Q< 0.9' lists the number of atoms with occupancy less than 0.9.

Mol	Type	Chain	Res	Atoms	RSCC	RSR	B-factors(Å ²)	Q<0.9
10	HR5	C	504	15/15	0.79	0.20	46,56,65,67	32
7	CA	B	503	1/1	0.83	0.12	96,96,96,96	0
6	MG	D	502	1/1	0.85	0.09	64,64,64,64	0
9	MES	B	504	12/12	0.88	0.14	72,77,90,99	0
11	ACP	F	401	31/31	0.89	0.11	83,90,99,104	0
7	CA	A	504	1/1	0.92	0.11	90,90,90,90	0
8	GDP	D	501	28/28	0.93	0.09	51,58,65,69	0

Continued on next page...

Continued from previous page...

Mol	Type	Chain	Res	Atoms	RSCC	RSR	B-factors(\AA^2)	Q<0.9
6	MG	F	402	1/1	0.93	0.10	77,77,77,77	0
5	GTP	A	501	32/32	0.97	0.06	37,43,46,48	0
7	CA	A	503	1/1	0.98	0.05	74,74,74,74	0
8	GDP	B	501	28/28	0.98	0.05	36,41,46,47	0
5	GTP	C	501	32/32	0.98	0.05	35,38,40,41	0
6	MG	A	502	1/1	0.99	0.03	40,40,40,40	0
6	MG	B	502	1/1	0.99	0.10	31,31,31,31	0
7	CA	C	503	1/1	0.99	0.04	53,53,53,53	0
6	MG	C	502	1/1	0.99	0.03	37,37,37,37	0

The following is a graphical depiction of the model fit to experimental electron density of all instances of the Ligand of Interest. In addition, ligands with molecular weight > 250 and outliers as shown on the geometry validation Tables will also be included. Each fit is shown from different orientation to approximate a three-dimensional view.

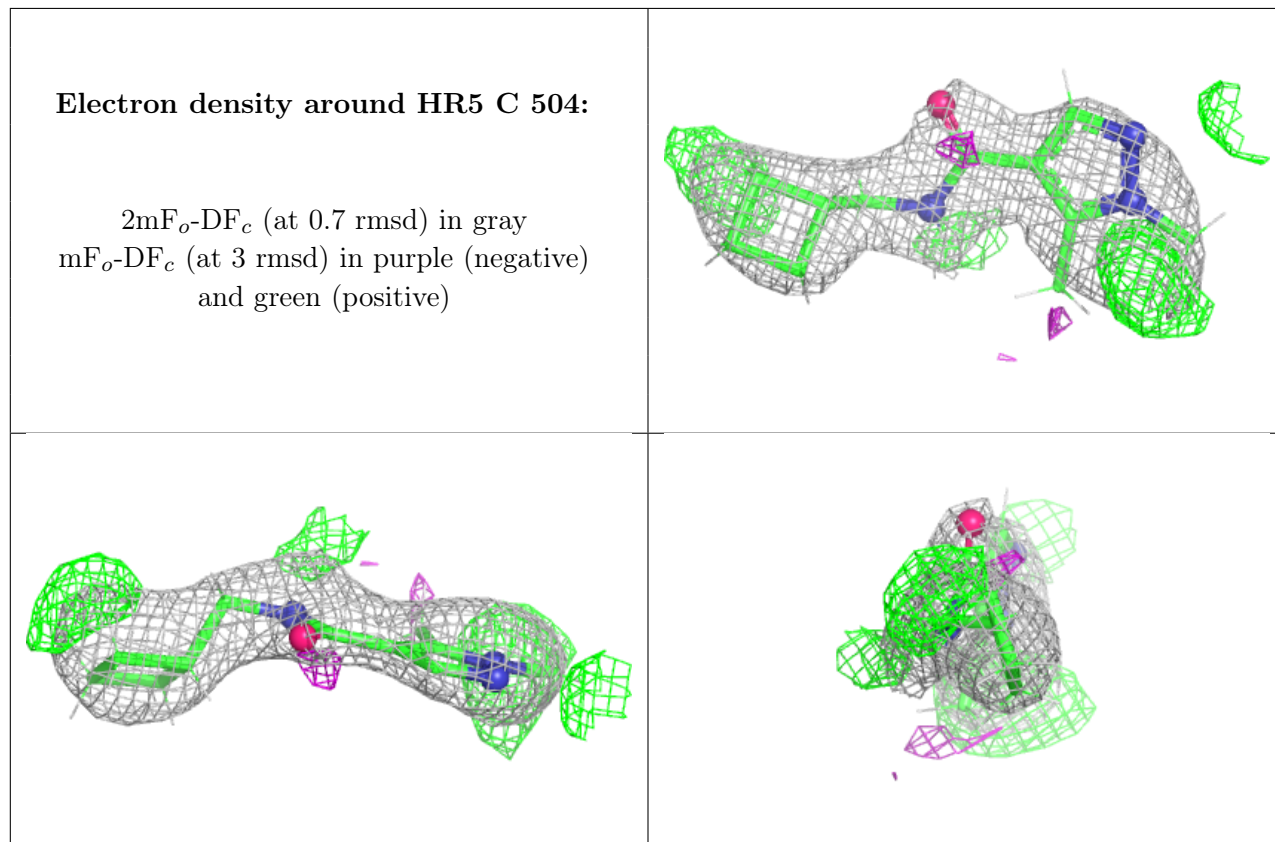

Electron density around ACP F 401:

$2mF_o-DF_c$ (at 0.7 rmsd) in gray
 mF_o-DF_c (at 3 rmsd) in purple (negative)
and green (positive)

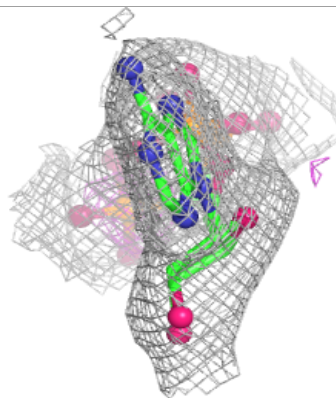
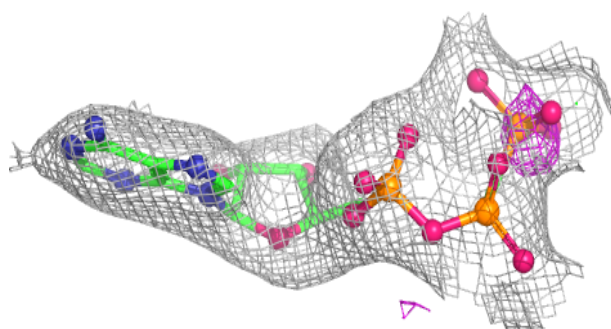
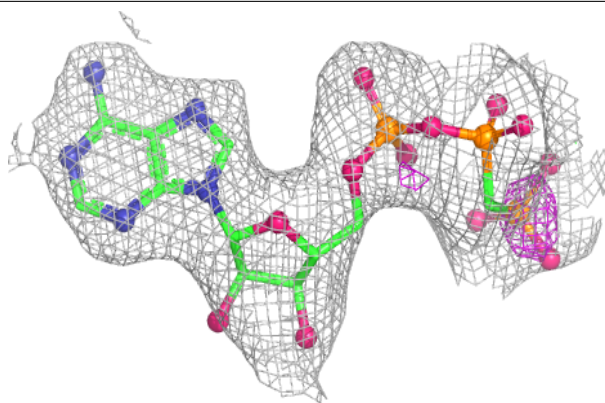
**Electron density around GDP D 501:**

$2mF_o-DF_c$ (at 0.7 rmsd) in gray
 mF_o-DF_c (at 3 rmsd) in purple (negative)
and green (positive)

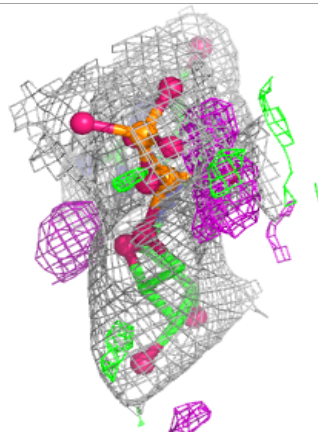
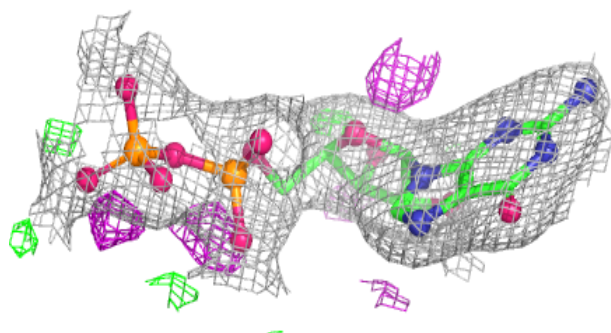
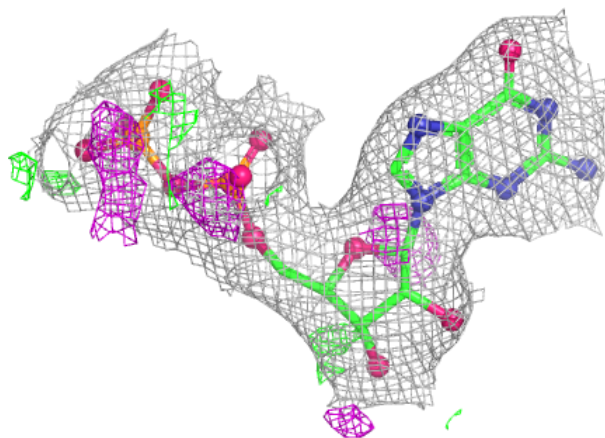

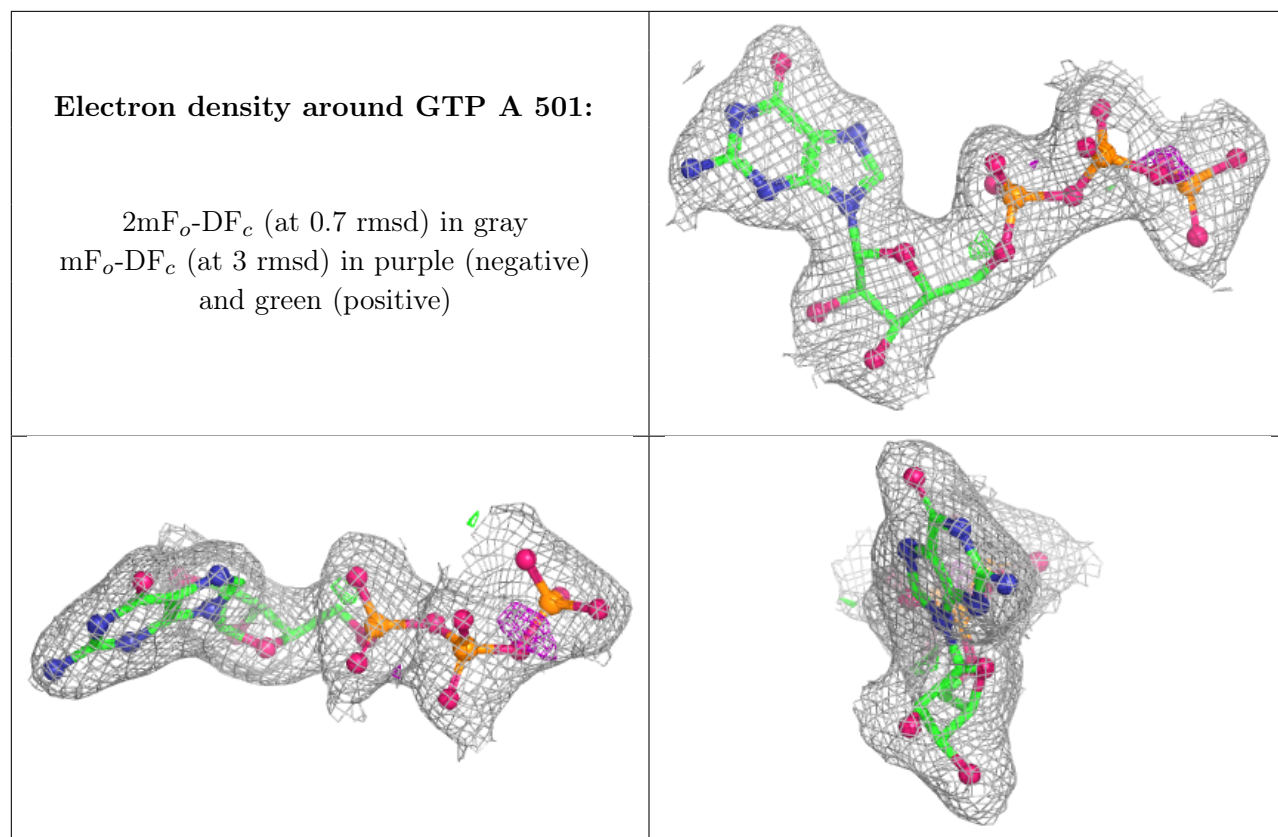

Electron density around GDP B 501:

$2mF_o-DF_c$ (at 0.7 rmsd) in gray
 mF_o-DF_c (at 3 rmsd) in purple (negative)
and green (positive)

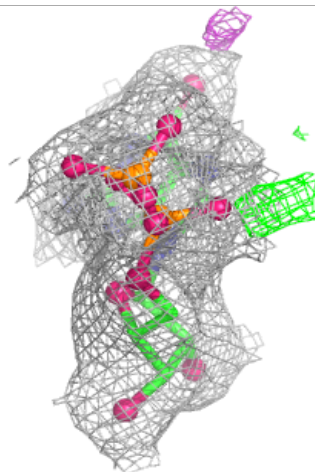
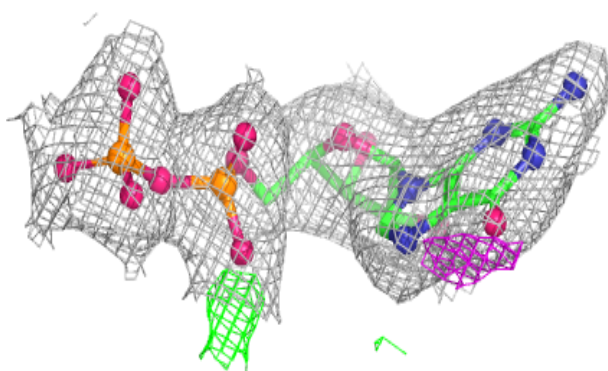
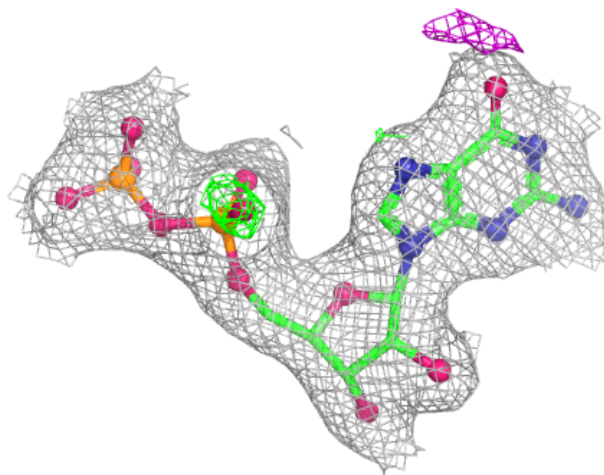

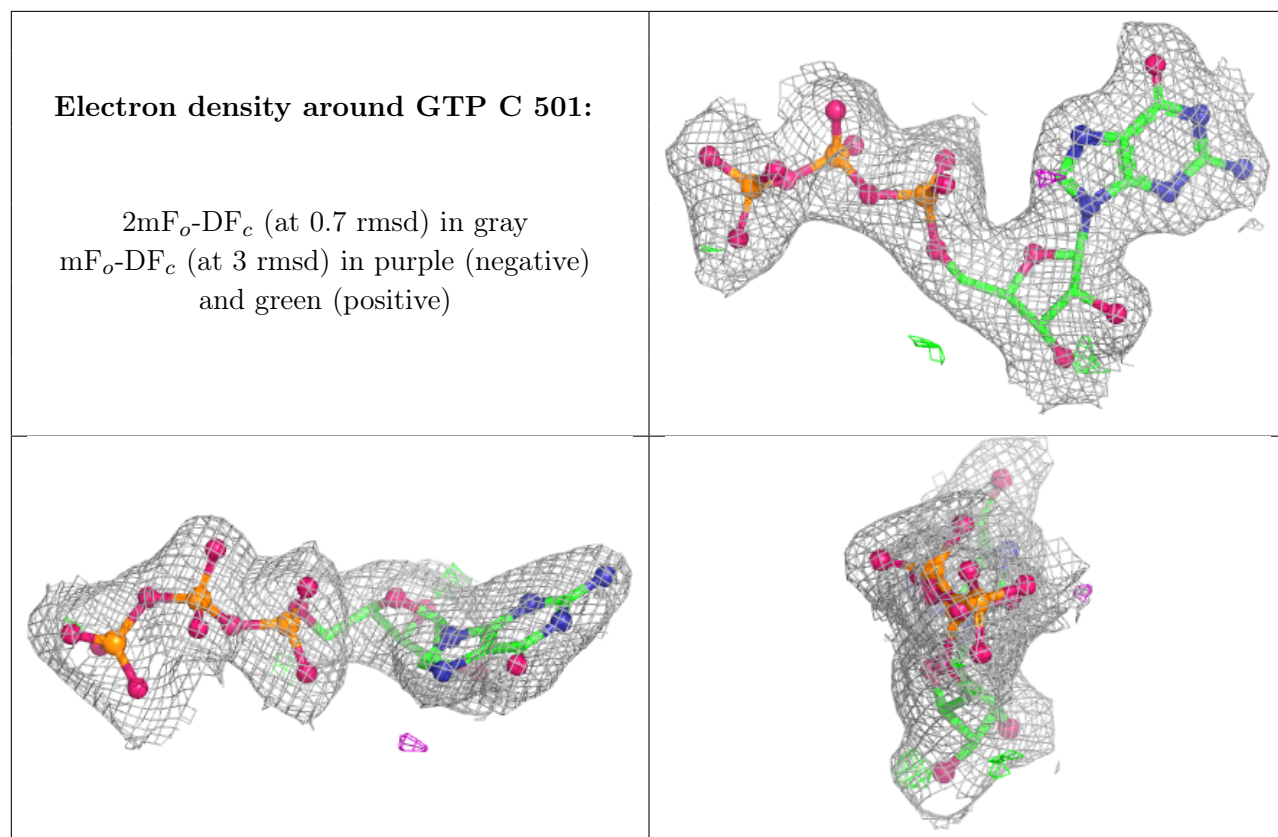

6.5 Other polymers [i](#)

There are no such residues in this entry.