



Full wwPDB X-ray Structure Validation Report ⓘ

Mar 31, 2026 – 12:17 PM EDT

PDB ID : 9Y7G / pdb_00009y7g
Title : CRYSTAL STRUCTURE OF THE A149T VARIANT OF SERINE HYDROXYMETHYLTRANSFERASE 8 FROM SOYBEAN CULTIVAR FORREST IN COMPLEX WITH PLP
Authors : Beamer, L.J.; Samarakoon, V.; Owuocha, L.F.
Deposited on : 2025-09-10
Resolution : 1.87 Å(reported)

This is a Full wwPDB X-ray Structure Validation Report for a publicly released PDB entry.

We welcome your comments at validation@mail.wwpdb.org

A user guide is available at

<https://www.wwpdb.org/validation/2017/XrayValidationReportHelp>

with specific help available everywhere you see the ⓘ symbol.

The types of validation reports are described at

<http://www.wwpdb.org/validation/2017/FAQs#types>.

The following versions of software and data (see [references ⓘ](#)) were used in the production of this report:

MolProbity : 4-5-2 with Phenix2.0
Mogul : 2022.3.0, CSD as543be (2022)
Xtrriage (Phenix) : 2.0
EDS : 3.0
Percentile statistics : 20231227.v01 (using entries in the PDB archive December 27th 2023)
CCP4 : 9.0.010 (Gargrove)
Density-Fitness : 1.0.12
Ideal geometry (proteins) : Engh & Huber (2001)
Ideal geometry (DNA, RNA) : Parkinson et al. (1996)
Validation Pipeline (wwPDB-VP) : 2.48.1

1 Overall quality at a glance

The following experimental techniques were used to determine the structure:

X-RAY DIFFRACTION

The reported resolution of this entry is 1.87 Å.

Percentile scores (ranging between 0-100) for global validation metrics of the entry are shown in the following graphic. The table shows the number of entries on which the scores are based.

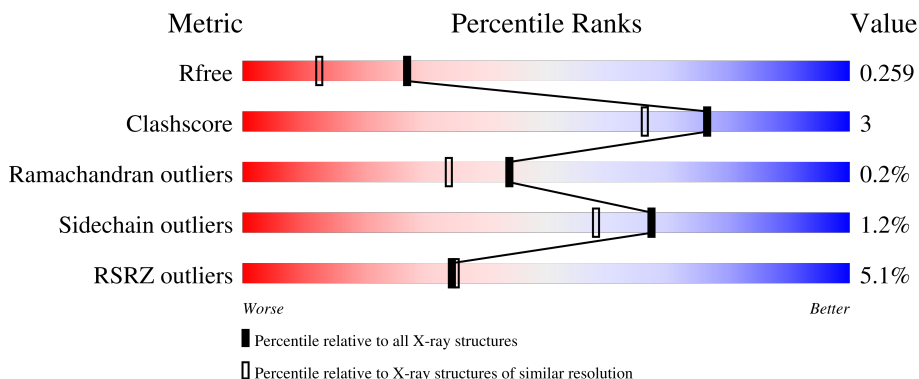

Metric	Whole archive (#Entries)	Similar resolution (#Entries, resolution range(Å))
R_{free}	164625	1090 (1.88-1.88)
Clashscore	180529	1144 (1.88-1.88)
Ramachandran outliers	177936	1135 (1.88-1.88)
Sidechain outliers	177891	1135 (1.88-1.88)
RSRZ outliers	164620	1090 (1.88-1.88)

The table below summarises the geometric issues observed across the polymeric chains and their fit to the electron density. The red, orange, yellow and green segments of the lower bar indicate the fraction of residues that contain outliers for ≥ 3 , 2, 1 and 0 types of geometric quality criteria respectively. A grey segment represents the fraction of residues that are not modelled. The numeric value for each fraction is indicated below the corresponding segment, with a dot representing fractions $\leq 5\%$. The upper red bar (where present) indicates the fraction of residues that have poor fit to the electron density. The numeric value is given above the bar.

Mol	Chain	Length	Quality of chain
1	A	492	
1	B	492	
1	C	492	
1	D	492	
1	E	492	

Continued on next page...

Continued from previous page...

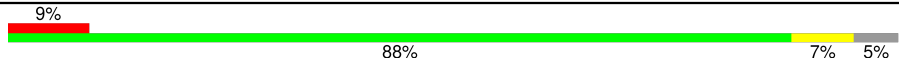
Mol	Chain	Length	Quality of chain
1	F	492	 <p>A horizontal bar chart representing the quality of the chain. The bar is divided into four segments: a red segment on the left labeled '9%', a large green segment labeled '88%', a yellow segment labeled '7%', and a grey segment on the far right labeled '5%'.</p>

2 Entry composition [i](#)

There are 2 unique types of molecules in this entry. The entry contains 22130 atoms, of which 0 are hydrogens and 0 are deuteriums.

In the tables below, the ZeroOcc column contains the number of atoms modelled with zero occupancy, the AltConf column contains the number of residues with at least one atom in alternate conformation and the Trace column contains the number of residues modelled with at most 2 atoms.

- Molecule 1 is a protein called Serine hydroxymethyltransferase.

Mol	Chain	Residues	Atoms						ZeroOcc	AltConf	Trace
			Total	C	N	O	P	S			
1	A	464	3537	2253	602	664	1	17	0	0	0
1	B	459	3493	2222	597	656	1	17	0	0	0
1	C	468	3547	2253	604	672	1	17	0	0	0
1	D	464	3495	2221	599	657	1	17	0	0	0
1	E	463	3508	2231	597	662	1	17	0	0	0
1	F	467	3505	2229	598	660	1	17	0	0	0

There are 132 discrepancies between the modelled and reference sequences:

Chain	Residue	Modelled	Actual	Comment	Reference
A	-20	MET	-	initiating methionine	UNP K4FW35
A	-19	GLY	-	expression tag	UNP K4FW35
A	-18	SER	-	expression tag	UNP K4FW35
A	-17	SER	-	expression tag	UNP K4FW35
A	-16	HIS	-	expression tag	UNP K4FW35
A	-15	HIS	-	expression tag	UNP K4FW35
A	-14	HIS	-	expression tag	UNP K4FW35
A	-13	HIS	-	expression tag	UNP K4FW35
A	-12	HIS	-	expression tag	UNP K4FW35
A	-11	HIS	-	expression tag	UNP K4FW35
A	-10	HIS	-	expression tag	UNP K4FW35
A	-9	SER	-	expression tag	UNP K4FW35
A	-8	SER	-	expression tag	UNP K4FW35
A	-7	GLY	-	expression tag	UNP K4FW35
A	-6	LEU	-	expression tag	UNP K4FW35
A	-5	VAL	-	expression tag	UNP K4FW35
A	-4	PRO	-	expression tag	UNP K4FW35

Continued on next page...

Continued from previous page...

Chain	Residue	Modelled	Actual	Comment	Reference
A	-3	ARG	-	expression tag	UNP K4FW35
A	-2	GLY	-	expression tag	UNP K4FW35
A	-1	SER	-	expression tag	UNP K4FW35
A	0	ASN	-	expression tag	UNP K4FW35
A	149	THR	ALA	engineered mutation	UNP K4FW35
B	-20	MET	-	initiating methionine	UNP K4FW35
B	-19	GLY	-	expression tag	UNP K4FW35
B	-18	SER	-	expression tag	UNP K4FW35
B	-17	SER	-	expression tag	UNP K4FW35
B	-16	HIS	-	expression tag	UNP K4FW35
B	-15	HIS	-	expression tag	UNP K4FW35
B	-14	HIS	-	expression tag	UNP K4FW35
B	-13	HIS	-	expression tag	UNP K4FW35
B	-12	HIS	-	expression tag	UNP K4FW35
B	-11	HIS	-	expression tag	UNP K4FW35
B	-10	HIS	-	expression tag	UNP K4FW35
B	-9	SER	-	expression tag	UNP K4FW35
B	-8	SER	-	expression tag	UNP K4FW35
B	-7	GLY	-	expression tag	UNP K4FW35
B	-6	LEU	-	expression tag	UNP K4FW35
B	-5	VAL	-	expression tag	UNP K4FW35
B	-4	PRO	-	expression tag	UNP K4FW35
B	-3	ARG	-	expression tag	UNP K4FW35
B	-2	GLY	-	expression tag	UNP K4FW35
B	-1	SER	-	expression tag	UNP K4FW35
B	0	ASN	-	expression tag	UNP K4FW35
B	149	THR	ALA	engineered mutation	UNP K4FW35
C	-20	MET	-	initiating methionine	UNP K4FW35
C	-19	GLY	-	expression tag	UNP K4FW35
C	-18	SER	-	expression tag	UNP K4FW35
C	-17	SER	-	expression tag	UNP K4FW35
C	-16	HIS	-	expression tag	UNP K4FW35
C	-15	HIS	-	expression tag	UNP K4FW35
C	-14	HIS	-	expression tag	UNP K4FW35
C	-13	HIS	-	expression tag	UNP K4FW35
C	-12	HIS	-	expression tag	UNP K4FW35
C	-11	HIS	-	expression tag	UNP K4FW35
C	-10	HIS	-	expression tag	UNP K4FW35
C	-9	SER	-	expression tag	UNP K4FW35
C	-8	SER	-	expression tag	UNP K4FW35
C	-7	GLY	-	expression tag	UNP K4FW35
C	-6	LEU	-	expression tag	UNP K4FW35

Continued on next page...

Continued from previous page...

Chain	Residue	Modelled	Actual	Comment	Reference
C	-5	VAL	-	expression tag	UNP K4FW35
C	-4	PRO	-	expression tag	UNP K4FW35
C	-3	ARG	-	expression tag	UNP K4FW35
C	-2	GLY	-	expression tag	UNP K4FW35
C	-1	SER	-	expression tag	UNP K4FW35
C	0	ASN	-	expression tag	UNP K4FW35
C	149	THR	ALA	engineered mutation	UNP K4FW35
D	-20	MET	-	initiating methionine	UNP K4FW35
D	-19	GLY	-	expression tag	UNP K4FW35
D	-18	SER	-	expression tag	UNP K4FW35
D	-17	SER	-	expression tag	UNP K4FW35
D	-16	HIS	-	expression tag	UNP K4FW35
D	-15	HIS	-	expression tag	UNP K4FW35
D	-14	HIS	-	expression tag	UNP K4FW35
D	-13	HIS	-	expression tag	UNP K4FW35
D	-12	HIS	-	expression tag	UNP K4FW35
D	-11	HIS	-	expression tag	UNP K4FW35
D	-10	HIS	-	expression tag	UNP K4FW35
D	-9	SER	-	expression tag	UNP K4FW35
D	-8	SER	-	expression tag	UNP K4FW35
D	-7	GLY	-	expression tag	UNP K4FW35
D	-6	LEU	-	expression tag	UNP K4FW35
D	-5	VAL	-	expression tag	UNP K4FW35
D	-4	PRO	-	expression tag	UNP K4FW35
D	-3	ARG	-	expression tag	UNP K4FW35
D	-2	GLY	-	expression tag	UNP K4FW35
D	-1	SER	-	expression tag	UNP K4FW35
D	0	ASN	-	expression tag	UNP K4FW35
D	149	THR	ALA	engineered mutation	UNP K4FW35
E	-20	MET	-	initiating methionine	UNP K4FW35
E	-19	GLY	-	expression tag	UNP K4FW35
E	-18	SER	-	expression tag	UNP K4FW35
E	-17	SER	-	expression tag	UNP K4FW35
E	-16	HIS	-	expression tag	UNP K4FW35
E	-15	HIS	-	expression tag	UNP K4FW35
E	-14	HIS	-	expression tag	UNP K4FW35
E	-13	HIS	-	expression tag	UNP K4FW35
E	-12	HIS	-	expression tag	UNP K4FW35
E	-11	HIS	-	expression tag	UNP K4FW35
E	-10	HIS	-	expression tag	UNP K4FW35
E	-9	SER	-	expression tag	UNP K4FW35
E	-8	SER	-	expression tag	UNP K4FW35

Continued on next page...

Continued from previous page...

Chain	Residue	Modelled	Actual	Comment	Reference
E	-7	GLY	-	expression tag	UNP K4FW35
E	-6	LEU	-	expression tag	UNP K4FW35
E	-5	VAL	-	expression tag	UNP K4FW35
E	-4	PRO	-	expression tag	UNP K4FW35
E	-3	ARG	-	expression tag	UNP K4FW35
E	-2	GLY	-	expression tag	UNP K4FW35
E	-1	SER	-	expression tag	UNP K4FW35
E	0	ASN	-	expression tag	UNP K4FW35
E	149	THR	ALA	engineered mutation	UNP K4FW35
F	-20	MET	-	initiating methionine	UNP K4FW35
F	-19	GLY	-	expression tag	UNP K4FW35
F	-18	SER	-	expression tag	UNP K4FW35
F	-17	SER	-	expression tag	UNP K4FW35
F	-16	HIS	-	expression tag	UNP K4FW35
F	-15	HIS	-	expression tag	UNP K4FW35
F	-14	HIS	-	expression tag	UNP K4FW35
F	-13	HIS	-	expression tag	UNP K4FW35
F	-12	HIS	-	expression tag	UNP K4FW35
F	-11	HIS	-	expression tag	UNP K4FW35
F	-10	HIS	-	expression tag	UNP K4FW35
F	-9	SER	-	expression tag	UNP K4FW35
F	-8	SER	-	expression tag	UNP K4FW35
F	-7	GLY	-	expression tag	UNP K4FW35
F	-6	LEU	-	expression tag	UNP K4FW35
F	-5	VAL	-	expression tag	UNP K4FW35
F	-4	PRO	-	expression tag	UNP K4FW35
F	-3	ARG	-	expression tag	UNP K4FW35
F	-2	GLY	-	expression tag	UNP K4FW35
F	-1	SER	-	expression tag	UNP K4FW35
F	0	ASN	-	expression tag	UNP K4FW35
F	149	THR	ALA	engineered mutation	UNP K4FW35

- Molecule 2 is water.

Mol	Chain	Residues	Atoms	ZeroOcc	AltConf
2	A	186	Total O 186 186	0	0
2	B	205	Total O 205 205	0	0
2	C	199	Total O 199 199	0	0
2	D	159	Total O 159 159	0	0

Continued on next page...

Continued from previous page...

Mol	Chain	Residues	Atoms		ZeroOcc	AltConf
2	E	161	Total	O	0	0
			161	161		
2	F	135	Total	O	0	0
			135	135		

3 Residue-property plots [i](#)

These plots are drawn for all protein, RNA, DNA and oligosaccharide chains in the entry. The first graphic for a chain summarises the proportions of the various outlier classes displayed in the second graphic. The second graphic shows the sequence view annotated by issues in geometry and electron density. Residues are color-coded according to the number of geometric quality criteria for which they contain at least one outlier: green = 0, yellow = 1, orange = 2 and red = 3 or more. A red dot above a residue indicates a poor fit to the electron density ($RSRZ > 2$). Stretches of 2 or more consecutive residues without any outlier are shown as a green connector. Residues present in the sample, but not in the model, are shown in grey.

- Molecule 1: Serine hydroxymethyltransferase

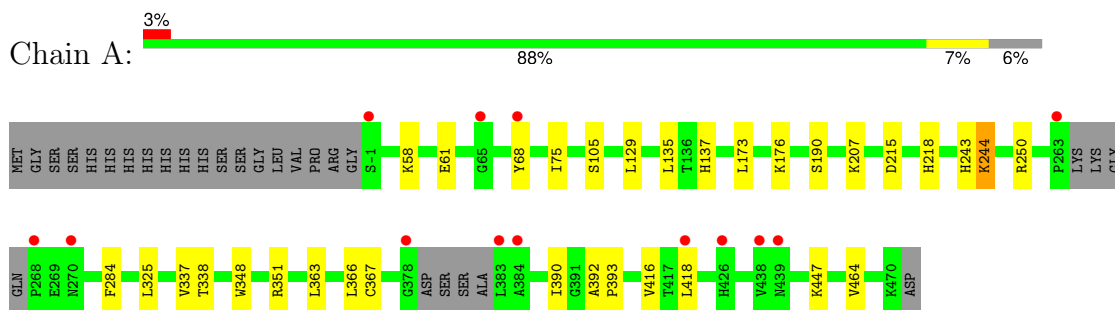

- Molecule 1: Serine hydroxymethyltransferase

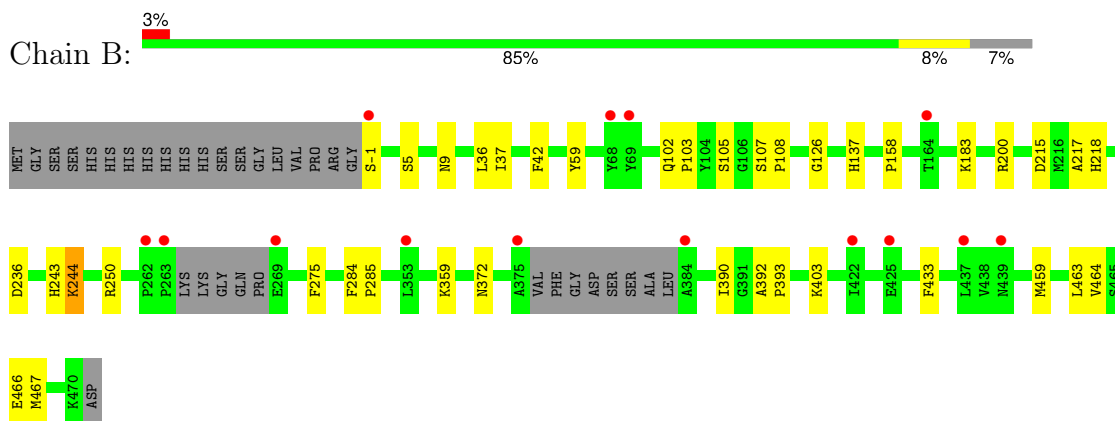

- Molecule 1: Serine hydroxymethyltransferase

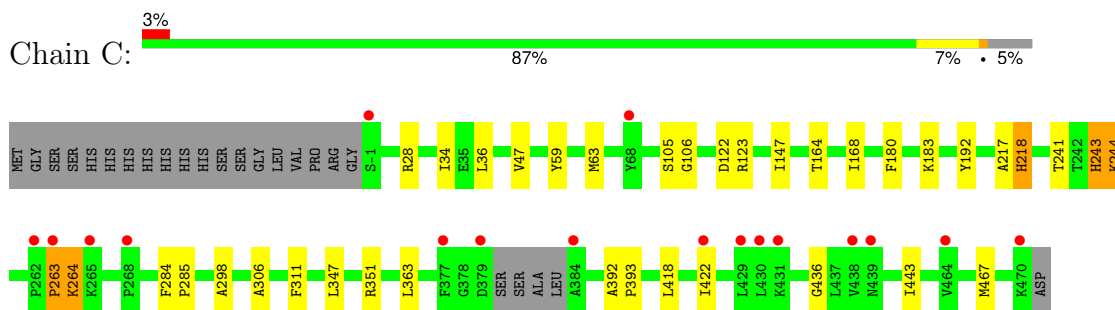

- Molecule 1: Serine hydroxymethyltransferase

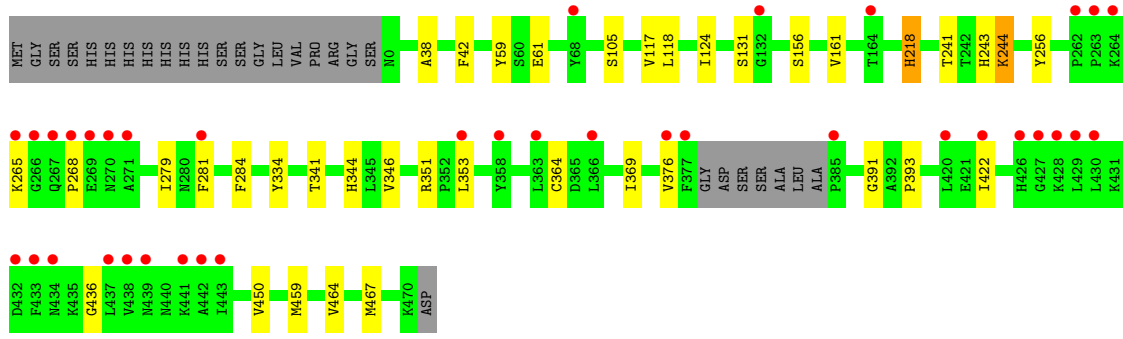
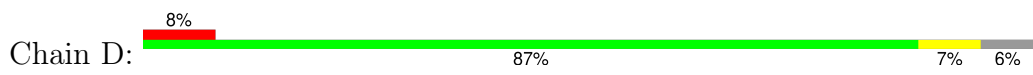

• Molecule 1: Serine hydroxymethyltransferase

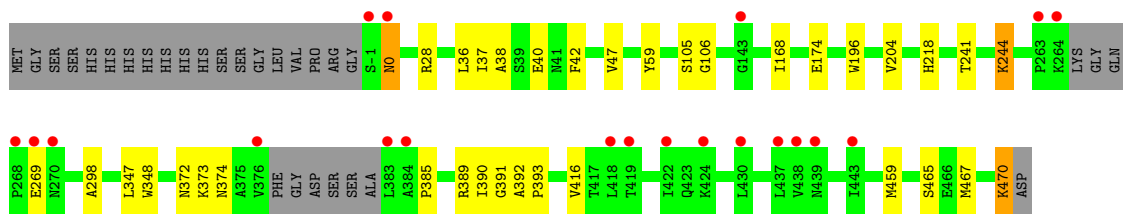
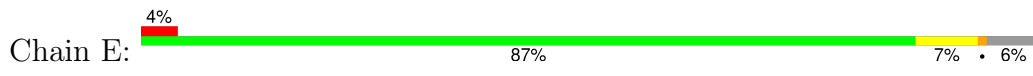

• Molecule 1: Serine hydroxymethyltransferase

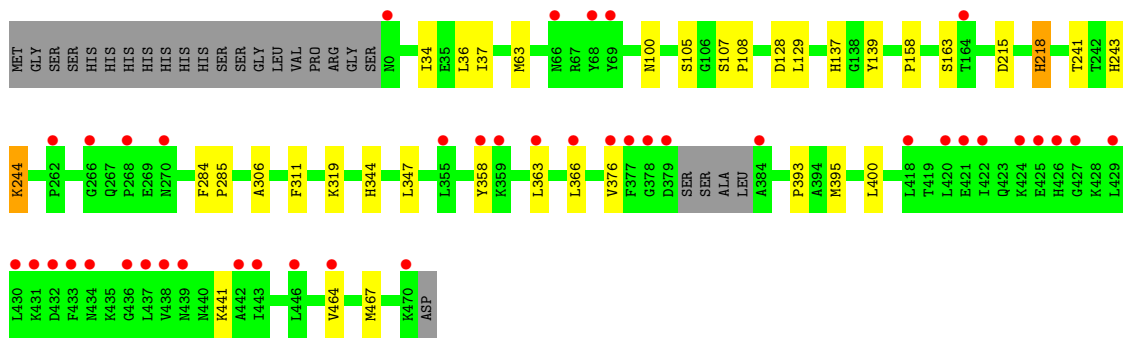
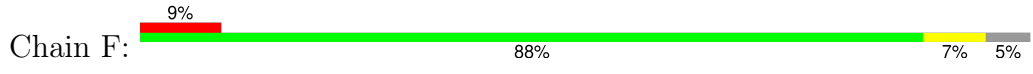

4 Data and refinement statistics

Property	Value	Source
Space group	P 31 2 1	Depositor
Cell constants a, b, c, α , β , γ	175.18Å 175.18Å 183.57Å 90.00° 90.00° 120.00°	Depositor
Resolution (Å)	48.75 – 1.87 48.75 – 1.87	Depositor EDS
% Data completeness (in resolution range)	99.2 (48.75-1.87) 99.3 (48.75-1.87)	Depositor EDS
R_{merge}	0.21	Depositor
R_{sym}	(Not available)	Depositor
$\langle I/\sigma(I) \rangle$ ¹	1.45 (at 1.87Å)	Xtrriage
Refinement program	PHENIX 1.21.2_5419	Depositor
R, R_{free}	0.217 , 0.252 0.225 , 0.259	Depositor DCC
R_{free} test set	13265 reflections (4.97%)	wwPDB-VP
Wilson B-factor (Å ²)	25.8	Xtrriage
Anisotropy	0.682	Xtrriage
Bulk solvent k_{sol} (e/Å ³), B_{sol} (Å ²)	0.32 , 37.5	EDS
L-test for twinning ²	$\langle L \rangle = 0.49$, $\langle L^2 \rangle = 0.32$	Xtrriage
Estimated twinning fraction	0.014 for -h,-k,l	Xtrriage
F_o, F_c correlation	0.96	EDS
Total number of atoms	22130	wwPDB-VP
Average B, all atoms (Å ²)	33.0	wwPDB-VP

Xtrriage's analysis on translational NCS is as follows: *The analyses of the Patterson function reveals a significant off-origin peak that is 28.02 % of the origin peak, indicating pseudo-translational symmetry. The chance of finding a peak of this or larger height randomly in a structure without pseudo-translational symmetry is equal to 1.9825e-03. The detected translational NCS is most likely also responsible for the elevated intensity ratio.*

¹Intensities estimated from amplitudes.

²Theoretical values of $\langle |L| \rangle$, $\langle L^2 \rangle$ for acentric reflections are 0.5, 0.333 respectively for untwinned datasets, and 0.375, 0.2 for perfectly twinned datasets.

5 Model quality i

5.1 Standard geometry i

Bond lengths and bond angles in the following residue types are not validated in this section: LLP

The Z score for a bond length (or angle) is the number of standard deviations the observed value is removed from the expected value. A bond length (or angle) with $|Z| > 5$ is considered an outlier worth inspection. RMSZ is the root-mean-square of all Z scores of the bond lengths (or angles).

Mol	Chain	Bond lengths		Bond angles	
		RMSZ	# Z >5	RMSZ	# Z >5
1	A	0.30	0/3593	0.49	0/4873
1	B	0.31	0/3547	0.48	0/4811
1	C	0.29	0/3605	0.48	0/4895
1	D	0.29	0/3553	0.48	0/4829
1	E	0.29	0/3563	0.48	0/4836
1	F	0.26	0/3562	0.45	0/4839
All	All	0.29	0/21423	0.48	0/29083

There are no bond length outliers.

There are no bond angle outliers.

There are no chirality outliers.

There are no planarity outliers.

5.2 Too-close contacts i

In the following table, the Non-H and H(model) columns list the number of non-hydrogen atoms and hydrogen atoms in the chain respectively. The H(added) column lists the number of hydrogen atoms added and optimized by MolProbity. The Clashes column lists the number of clashes within the asymmetric unit, whereas Symm-Clashes lists symmetry-related clashes.

Mol	Chain	Non-H	H(model)	H(added)	Clashes	Symm-Clashes
1	A	3537	0	3406	21	0
1	B	3493	0	3359	19	0
1	C	3547	0	3371	23	0
1	D	3495	0	3294	19	0
1	E	3508	0	3349	18	0
1	F	3505	0	3316	18	0
2	A	186	0	0	2	0

Continued on next page...

Continued from previous page...

Mol	Chain	Non-H	H(model)	H(added)	Clashes	Symm-Clashes
2	B	205	0	0	0	0
2	C	199	0	0	0	0
2	D	159	0	0	0	0
2	E	161	0	0	0	0
2	F	135	0	0	0	0
All	All	22130	0	20095	117	0

The all-atom clashscore is defined as the number of clashes found per 1000 atoms (including hydrogen atoms). The all-atom clashscore for this structure is 3.

All (117) close contacts within the same asymmetric unit are listed below, sorted by their clash magnitude.

Atom-1	Atom-2	Interatomic distance (Å)	Clash overlap (Å)
1:B:5:SER:HA	1:B:9:ASN:HD22	1.48	0.79
1:C:418:LEU:HD21	1:C:443:ILE:HG12	1.79	0.64
1:B:464:VAL:O	1:B:467:MET:HG3	2.00	0.62
1:F:395:MET:HB3	1:F:400:LEU:HD22	1.82	0.61
1:D:334:TYR:HE1	1:D:353:LEU:HD21	1.66	0.59
1:B:463:LEU:HB2	1:B:466:GLU:HG3	1.89	0.55
1:F:464:VAL:HG13	1:F:467:MET:HE2	1.88	0.54
1:D:364:CYS:HB3	1:D:369:ILE:HB	1.90	0.53
1:D:241:THR:HB	1:D:243:HIS:CE1	2.42	0.53
1:D:344:HIS:HB2	1:D:393:PRO:HD3	1.90	0.53
1:A:337:VAL:HG12	1:A:338:THR:HG23	1.90	0.53
1:C:218:HIS:HD2	1:C:244:LLP:O3	1.92	0.52
1:E:37:ILE:HG23	1:E:372:ASN:HD21	1.74	0.52
1:A:366:LEU:O	1:A:447:LYS:HD3	2.09	0.51
1:D:334:TYR:CE1	1:D:353:LEU:HD21	2.46	0.51
1:D:351:ARG:HH11	1:D:376:VAL:HG23	1.76	0.51
1:E:347:LEU:HD11	1:E:374:ASN:ND2	2.26	0.51
1:C:217:ALA:HB1	1:C:244:LLP:HE2	1.92	0.50
1:E:174:GLU:HB2	1:E:204:VAL:HG22	1.95	0.49
1:E:42:PHE:CD1	1:E:459:MET:HE1	2.48	0.49
1:F:34:ILE:HG22	1:F:36:LEU:HG	1.95	0.49
1:D:131:SER:HB3	1:D:161:VAL:HG13	1.95	0.49
1:E:106:GLY:HA3	1:E:241:THR:HG22	1.94	0.49
1:C:122:ASP:OD2	1:C:183:LYS:HE2	2.12	0.49
1:F:129:LEU:HD12	1:F:139:TYR:CG	2.48	0.49
1:D:422:ILE:HG23	1:D:436:GLY:HA3	1.94	0.49
1:B:37:ILE:HG23	1:B:372:ASN:OD1	2.12	0.48
1:F:107:SER:HB2	1:F:108:PRO:HD3	1.95	0.48

Continued on next page...

Continued from previous page...

Atom-1	Atom-2	Interatomic distance (Å)	Clash overlap (Å)
1:A:348:TRP:CH2	1:A:416:VAL:HG21	2.48	0.48
1:F:137:HIS:HE1	1:F:215:ASP:OD2	1.95	0.48
1:C:106:GLY:HA3	1:C:241:THR:HG22	1.95	0.48
1:F:218:HIS:HD2	1:F:244:LLP:O3	1.95	0.48
1:D:218:HIS:HD2	1:D:244:LLP:O3	1.97	0.47
1:C:147:ILE:HD12	1:D:281:PHE:HZ	1.80	0.47
1:F:363:LEU:HA	1:F:366:LEU:HD12	1.97	0.47
1:D:61:GLU:HB3	1:D:284:PHE:CZ	2.50	0.46
1:F:128:ASP:HB2	1:F:158:PRO:HB2	1.96	0.46
1:C:351:ARG:HE	1:C:351:ARG:HB2	1.54	0.46
1:C:168:ILE:HG13	1:C:192:TYR:CZ	2.51	0.46
1:E:0:ASN:HD22	1:E:0:ASN:N	2.13	0.46
1:A:363:LEU:HD11	1:A:418:LEU:HG	1.98	0.46
1:C:392:ALA:N	1:C:393:PRO:HD3	2.31	0.46
1:F:464:VAL:HG13	1:F:467:MET:CE	2.47	0.45
1:A:137:HIS:HE1	1:A:215:ASP:OD2	1.99	0.45
1:A:351:ARG:HE	1:A:351:ARG:HB2	1.56	0.45
1:E:348:TRP:CH2	1:E:416:VAL:HG21	2.51	0.45
1:F:284:PHE:CD1	1:F:285:PRO:HA	2.52	0.45
1:C:28:ARG:HA	1:C:467:MET:HE1	1.99	0.45
1:C:123:ARG:HB3	1:C:180:PHE:CE2	2.52	0.45
1:E:168:ILE:HD11	1:E:196:TRP:CZ3	2.52	0.45
1:A:58:LYS:HG2	1:A:75:ILE:HG13	1.97	0.45
1:E:218:HIS:HD2	1:E:244:LLP:O3	2.00	0.45
1:F:358:TYR:C	1:F:358:TYR:CD1	2.94	0.45
1:F:306:ALA:HA	1:F:311:PHE:CG	2.52	0.45
1:E:47:VAL:HG13	1:E:298:ALA:HB1	1.99	0.45
1:D:38:ALA:HA	1:D:391:GLY:HA3	2.00	0.44
1:B:42:PHE:CD1	1:B:459:MET:HE1	2.53	0.44
1:C:284:PHE:CD1	1:C:285:PRO:HA	2.53	0.44
1:C:392:ALA:N	1:C:393:PRO:CD	2.81	0.44
1:F:319:LYS:HB3	1:F:319:LYS:HE2	1.72	0.44
1:C:47:VAL:HG13	1:C:298:ALA:HB1	1.99	0.44
1:B:236:ASP:HB3	1:B:275:PHE:CE2	2.53	0.44
1:B:218:HIS:HD2	1:B:244:LLP:O3	2.01	0.43
1:B:243:HIS:ND1	1:B:250:ARG:HA	2.33	0.43
1:C:63:MET:HE3	1:C:63:MET:HB3	1.91	0.43
1:F:344:HIS:HB2	1:F:393:PRO:HD3	1.99	0.43
1:C:363:LEU:HD21	1:C:418:LEU:HD23	1.99	0.43
1:A:218:HIS:HD2	1:A:244:LLP:O3	2.02	0.43
1:C:347:LEU:HD12	1:C:347:LEU:HA	1.83	0.43

Continued on next page...

Continued from previous page...

Atom-1	Atom-2	Interatomic distance (Å)	Clash overlap (Å)
1:A:243:HIS:ND1	1:A:250:ARG:HA	2.33	0.43
1:B:36:LEU:HB3	1:B:390:ILE:HG23	2.00	0.43
1:A:176:LYS:HE2	2:A:587:HOH:O	2.18	0.42
1:A:464:VAL:HG23	2:A:633:HOH:O	2.18	0.42
1:D:42:PHE:CD1	1:D:459:MET:HE1	2.53	0.42
1:A:392:ALA:N	1:A:393:PRO:HD3	2.34	0.42
1:E:373:LYS:HD2	1:E:385:PRO:HG2	2.00	0.42
1:B:126:GLY:O	1:B:158:PRO:HA	2.20	0.42
1:B:403:LYS:HA	1:B:403:LYS:HD2	1.87	0.42
1:E:28:ARG:HA	1:E:467:MET:HE1	2.01	0.42
1:E:392:ALA:N	1:E:393:PRO:CD	2.82	0.42
1:F:241:THR:HB	1:F:243:HIS:CE1	2.55	0.42
1:A:68:TYR:CE2	1:A:284:PHE:HE2	2.37	0.42
1:A:207:LYS:HE3	1:A:207:LYS:HB2	1.91	0.42
1:A:392:ALA:H	1:A:393:PRO:HD3	1.85	0.42
1:B:200:ARG:HA	1:B:200:ARG:HD2	1.76	0.42
1:A:190:SER:HA	1:A:218:HIS:CD2	2.54	0.42
1:C:241:THR:HB	1:C:243:HIS:CE1	2.54	0.42
1:E:36:LEU:HB3	1:E:390:ILE:HG23	2.02	0.42
1:C:422:ILE:HG23	1:C:436:GLY:HA3	2.01	0.42
1:D:464:VAL:O	1:D:467:MET:HG3	2.19	0.42
1:D:117:VAL:HG23	1:D:118:LEU:HG	2.02	0.41
1:D:124:ILE:O	1:D:156:SER:HA	2.20	0.41
1:B:102:GLN:N	1:B:103:PRO:CD	2.84	0.41
1:B:217:ALA:HB1	1:B:244:LLP:HE2	2.01	0.41
1:C:34:ILE:HG22	1:C:36:LEU:HG	2.02	0.41
1:D:341:THR:HB	1:D:346:VAL:HG12	2.01	0.41
1:E:37:ILE:HB	1:E:40:GLU:HB2	2.02	0.41
1:E:372:ASN:ND2	1:E:389:ARG:HH21	2.19	0.41
1:F:63:MET:HE1	1:F:100:ASN:ND2	2.36	0.41
1:A:129:LEU:HD11	1:A:135:LEU:HA	2.01	0.41
1:C:284:PHE:CG	1:C:285:PRO:HA	2.55	0.41
1:F:129:LEU:HD12	1:F:139:TYR:CD1	2.56	0.41
1:B:359:LYS:HD3	1:B:433:PHE:CE1	2.56	0.41
1:A:325:LEU:HD21	1:A:390:ILE:HG21	2.03	0.41
1:D:256:TYR:HB3	1:D:279:ILE:HD12	2.03	0.41
1:A:61:GLU:HB3	1:A:284:PHE:CZ	2.56	0.41
1:B:284:PHE:CD1	1:B:285:PRO:HA	2.56	0.41
1:E:38:ALA:HA	1:E:391:GLY:HA3	2.02	0.41
1:B:137:HIS:HE1	1:B:215:ASP:OD2	2.03	0.40
1:D:369:ILE:HD11	1:D:450:VAL:HG21	2.02	0.40

Continued on next page...

Continued from previous page...

Atom-1	Atom-2	Interatomic distance (Å)	Clash overlap (Å)
1:E:470:LYS:HE2	1:E:470:LYS:HB3	1.94	0.40
1:C:263:PRO:O	1:C:264:LYS:HB3	2.21	0.40
1:A:392:ALA:N	1:A:393:PRO:CD	2.84	0.40
1:B:392:ALA:N	1:B:393:PRO:CD	2.85	0.40
1:C:306:ALA:HA	1:C:311:PHE:CG	2.56	0.40
1:A:367:CYS:HA	1:A:447:LYS:HB2	2.02	0.40
1:B:107:SER:HB2	1:B:108:PRO:HD3	2.03	0.40

There are no symmetry-related clashes.

5.3 Torsion angles [i](#)

5.3.1 Protein backbone [i](#)

In the following table, the Percentiles column shows the percent Ramachandran outliers of the chain as a percentile score with respect to all X-ray entries followed by that with respect to entries of similar resolution.

The Analysed column shows the number of residues for which the backbone conformation was analysed, and the total number of residues.

Mol	Chain	Analysed	Favoured	Allowed	Outliers	Percentiles	
1	A	457/492 (93%)	442 (97%)	15 (3%)	0	100	100
1	B	452/492 (92%)	440 (97%)	12 (3%)	0	100	100
1	C	463/492 (94%)	451 (97%)	9 (2%)	3 (1%)	22	10
1	D	459/492 (93%)	443 (96%)	14 (3%)	2 (0%)	30	18
1	E	456/492 (93%)	445 (98%)	10 (2%)	1 (0%)	44	34
1	F	462/492 (94%)	445 (96%)	17 (4%)	0	100	100
All	All	2749/2952 (93%)	2666 (97%)	77 (3%)	6 (0%)	44	34

All (6) Ramachandran outliers are listed below:

Mol	Chain	Res	Type
1	C	263	PRO
1	D	268	PRO
1	E	269	GLU
1	D	265	LYS
1	C	243	HIS
1	C	264	LYS

5.3.2 Protein sidechains [i](#)

In the following table, the Percentiles column shows the percent sidechain outliers of the chain as a percentile score with respect to all X-ray entries followed by that with respect to entries of similar resolution.

The Analysed column shows the number of residues for which the sidechain conformation was analysed, and the total number of residues.

Mol	Chain	Analysed	Rotameric	Outliers	Percentiles	
1	A	358/403 (89%)	356 (99%)	2 (1%)	84	80
1	B	353/403 (88%)	349 (99%)	4 (1%)	70	62
1	C	355/403 (88%)	351 (99%)	4 (1%)	70	62
1	D	344/403 (85%)	341 (99%)	3 (1%)	75	69
1	E	352/403 (87%)	347 (99%)	5 (1%)	62	52
1	F	345/403 (86%)	338 (98%)	7 (2%)	50	36
All	All	2107/2418 (87%)	2082 (99%)	25 (1%)	67	58

All (25) residues with a non-rotameric sidechain are listed below:

Mol	Chain	Res	Type
1	A	105	SER
1	A	173	LEU
1	B	-1	SER
1	B	59	TYR
1	B	105	SER
1	B	183	LYS
1	C	59	TYR
1	C	105	SER
1	C	164	THR
1	C	218	HIS
1	D	59	TYR
1	D	105	SER
1	D	218	HIS
1	E	0	ASN
1	E	59	TYR
1	E	105	SER
1	E	465	SER
1	E	470	LYS
1	F	37	ILE
1	F	105	SER
1	F	163	SER
1	F	218	HIS

Continued on next page...

Continued from previous page...

Mol	Chain	Res	Type
1	F	347	LEU
1	F	376	VAL
1	F	441	LYS

Sometimes sidechains can be flipped to improve hydrogen bonding and reduce clashes. All (27) such sidechains are listed below:

Mol	Chain	Res	Type
1	A	9	ASN
1	A	137	HIS
1	A	293	ASN
1	A	372	ASN
1	B	0	ASN
1	B	9	ASN
1	B	66	ASN
1	B	137	HIS
1	B	293	ASN
1	B	407	GLN
1	C	95	GLN
1	C	317	GLN
1	C	372	ASN
1	C	407	GLN
1	D	407	GLN
1	E	0	ASN
1	E	20	HIS
1	E	293	ASN
1	E	372	ASN
1	E	374	ASN
1	E	407	GLN
1	F	20	HIS
1	F	95	GLN
1	F	137	HIS
1	F	292	HIS
1	F	295	GLN
1	F	407	GLN

5.3.3 RNA [i](#)

There are no RNA molecules in this entry.

5.4 Non-standard residues in protein, DNA, RNA chains

6 non-standard protein/DNA/RNA residues are modelled in this entry.

In the following table, the Counts columns list the number of bonds (or angles) for which Mogul statistics could be retrieved, the number of bonds (or angles) that are observed in the model and the number of bonds (or angles) that are defined in the Chemical Component Dictionary. The Link column lists molecule types, if any, to which the group is linked. The Z score for a bond length (or angle) is the number of standard deviations the observed value is removed from the expected value. A bond length (or angle) with $|Z| > 2$ is considered an outlier worth inspection. RMSZ is the root-mean-square of all Z scores of the bond lengths (or angles).

Mol	Type	Chain	Res	Link	Bond lengths			Bond angles		
					Counts	RMSZ	# Z > 2	Counts	RMSZ	# Z > 2
1	LLP	E	244	1	23,24,25	1.08	1 (4%)	25,32,34	1.49	4 (16%)
1	LLP	F	244	1	23,24,25	1.11	1 (4%)	25,32,34	1.54	6 (24%)
1	LLP	A	244	1	23,24,25	1.14	1 (4%)	25,32,34	1.41	6 (24%)
1	LLP	B	244	1	23,24,25	1.02	1 (4%)	25,32,34	1.78	6 (24%)
1	LLP	D	244	1	23,24,25	1.11	1 (4%)	25,32,34	1.56	4 (16%)
1	LLP	C	244	1	23,24,25	1.15	2 (8%)	25,32,34	1.82	6 (24%)

In the following table, the Chirals column lists the number of chiral outliers, the number of chiral centers analysed, the number of these observed in the model and the number defined in the Chemical Component Dictionary. Similar counts are reported in the Torsion and Rings columns. '-' means no outliers of that kind were identified.

Mol	Type	Chain	Res	Link	Chirals	Torsions	Rings
1	LLP	E	244	1	-	7/16/17/19	0/1/1/1
1	LLP	F	244	1	-	10/16/17/19	0/1/1/1
1	LLP	A	244	1	-	7/16/17/19	0/1/1/1
1	LLP	B	244	1	-	7/16/17/19	0/1/1/1
1	LLP	D	244	1	-	7/16/17/19	0/1/1/1
1	LLP	C	244	1	-	7/16/17/19	0/1/1/1

All (7) bond length outliers are listed below:

Mol	Chain	Res	Type	Atoms	Z	Observed(Å)	Ideal(Å)
1	F	244	LLP	P-OP4	3.64	1.71	1.60
1	A	244	LLP	P-OP4	3.62	1.71	1.60
1	D	244	LLP	P-OP4	3.52	1.71	1.60
1	E	244	LLP	P-OP4	3.44	1.71	1.60
1	C	244	LLP	P-OP4	3.42	1.71	1.60

Continued on next page...

Continued from previous page...

Mol	Chain	Res	Type	Atoms	Z	Observed(Å)	Ideal(Å)
1	B	244	LLP	P-OP4	3.17	1.70	1.60
1	C	244	LLP	O3-C3	-2.23	1.31	1.36

All (32) bond angle outliers are listed below:

Mol	Chain	Res	Type	Atoms	Z	Observed(°)	Ideal(°)
1	C	244	LLP	C5-C4-C4'	4.93	129.07	121.47
1	B	244	LLP	OP4-C5'-C5	3.93	116.72	109.36
1	B	244	LLP	CE-NZ-C4'	3.66	130.44	118.72
1	C	244	LLP	C3-C4-C4'	-3.57	113.95	120.40
1	B	244	LLP	C5-C4-C4'	3.34	126.63	121.47
1	D	244	LLP	OP4-C5'-C5	3.34	115.61	109.36
1	F	244	LLP	OP4-C5'-C5	3.11	115.19	109.36
1	D	244	LLP	OP2-P-OP4	-3.09	98.62	106.67
1	E	244	LLP	C5-C4-C4'	2.93	126.00	121.47
1	D	244	LLP	CE-NZ-C4'	2.76	127.56	118.72
1	E	244	LLP	CE-NZ-C4'	2.73	127.46	118.72
1	F	244	LLP	CE-NZ-C4'	2.73	127.45	118.72
1	A	244	LLP	OP4-C5'-C5	2.71	114.43	109.36
1	B	244	LLP	C3-C4-C4'	-2.55	115.79	120.40
1	F	244	LLP	C5-C4-C4'	2.50	125.33	121.47
1	C	244	LLP	OP4-C5'-C5	2.43	113.91	109.36
1	B	244	LLP	OP3-P-OP2	2.39	116.76	107.80
1	D	244	LLP	OP3-P-OP2	2.37	116.69	107.80
1	C	244	LLP	CG-CD-CE	2.34	121.51	113.38
1	C	244	LLP	CE-NZ-C4'	2.25	125.94	118.72
1	A	244	LLP	CE-NZ-C4'	2.25	125.93	118.72
1	A	244	LLP	OP2-P-OP4	-2.24	100.82	106.67
1	E	244	LLP	OP4-P-OP1	-2.23	100.41	106.44
1	A	244	LLP	C5'-C5-C6	-2.20	115.78	119.36
1	A	244	LLP	OP3-P-OP2	2.19	116.02	107.80
1	A	244	LLP	C5-C4-C4'	2.19	124.85	121.47
1	F	244	LLP	C4-C3-C2	2.15	121.36	120.14
1	F	244	LLP	OP3-P-OP2	2.15	115.85	107.80
1	C	244	LLP	OP4-P-OP1	-2.13	100.69	106.44
1	B	244	LLP	C4-C3-C2	2.06	121.30	120.14
1	F	244	LLP	C5'-C5-C6	-2.02	116.07	119.36
1	E	244	LLP	C3-C4-C5	-2.01	116.67	118.28

There are no chirality outliers.

All (45) torsion outliers are listed below:

Mol	Chain	Res	Type	Atoms
1	A	244	LLP	C4-C4'-NZ-CE
1	A	244	LLP	O-C-CA-CB
1	A	244	LLP	CG-CD-CE-NZ
1	B	244	LLP	C4-C4'-NZ-CE
1	B	244	LLP	O-C-CA-CB
1	C	244	LLP	C4-C4'-NZ-CE
1	C	244	LLP	O-C-CA-CB
1	D	244	LLP	C4-C4'-NZ-CE
1	D	244	LLP	O-C-CA-CB
1	E	244	LLP	C4-C4'-NZ-CE
1	E	244	LLP	O-C-CA-CB
1	E	244	LLP	CG-CD-CE-NZ
1	F	244	LLP	C4-C4'-NZ-CE
1	F	244	LLP	C4-C5-C5'-OP4
1	F	244	LLP	C6-C5-C5'-OP4
1	F	244	LLP	C5'-OP4-P-OP2
1	F	244	LLP	O-C-CA-CB
1	F	244	LLP	CG-CD-CE-NZ
1	B	244	LLP	CG-CD-CE-NZ
1	C	244	LLP	CG-CD-CE-NZ
1	D	244	LLP	CG-CD-CE-NZ
1	A	244	LLP	C3-C4-C4'-NZ
1	E	244	LLP	C3-C4-C4'-NZ
1	A	244	LLP	C5-C4-C4'-NZ
1	B	244	LLP	C5-C4-C4'-NZ
1	B	244	LLP	C3-C4-C4'-NZ
1	C	244	LLP	C3-C4-C4'-NZ
1	F	244	LLP	C3-C4-C4'-NZ
1	B	244	LLP	CE-CD-CG-CB
1	D	244	LLP	CE-CD-CG-CB
1	F	244	LLP	CE-CD-CG-CB
1	D	244	LLP	C3-C4-C4'-NZ
1	C	244	LLP	C5-C4-C4'-NZ
1	E	244	LLP	C5-C4-C4'-NZ
1	F	244	LLP	C5-C4-C4'-NZ
1	A	244	LLP	CE-CD-CG-CB
1	E	244	LLP	CE-CD-CG-CB
1	D	244	LLP	C5-C4-C4'-NZ
1	C	244	LLP	CE-CD-CG-CB
1	F	244	LLP	CD-CE-NZ-C4'
1	D	244	LLP	CD-CE-NZ-C4'
1	E	244	LLP	CD-CE-NZ-C4'
1	B	244	LLP	CD-CE-NZ-C4'

Continued on next page...

Continued from previous page...

Mol	Chain	Res	Type	Atoms
1	A	244	LLP	CD-CE-NZ-C4'
1	C	244	LLP	CD-CE-NZ-C4'

There are no ring outliers.

6 monomers are involved in 8 short contacts:

Mol	Chain	Res	Type	Clashes	Symm-Clashes
1	E	244	LLP	1	0
1	F	244	LLP	1	0
1	A	244	LLP	1	0
1	B	244	LLP	2	0
1	D	244	LLP	1	0
1	C	244	LLP	2	0

5.5 Carbohydrates [i](#)

There are no oligosaccharides in this entry.

5.6 Ligand geometry [i](#)

There are no ligands in this entry.

5.7 Other polymers [i](#)

There are no such residues in this entry.

5.8 Polymer linkage issues [i](#)

There are no chain breaks in this entry.

6 Fit of model and data

6.1 Protein, DNA and RNA chains

In the following table, the column labelled ‘#RSRZ> 2’ contains the number (and percentage) of RSRZ outliers, followed by percent RSRZ outliers for the chain as percentile scores relative to all X-ray entries and entries of similar resolution. The OWAB column contains the minimum, median, 95th percentile and maximum values of the occupancy-weighted average B-factor per residue. The column labelled ‘Q< 0.9’ lists the number of (and percentage) of residues with an average occupancy less than 0.9.

Mol	Chain	Analysed	<RSRZ>	#RSRZ>2	OWAB(Å ²)	Q<0.9
1	A	463/492 (94%)	0.14	13 (2%) 55 59	19, 29, 52, 72	0
1	B	458/492 (93%)	0.21	14 (3%) 51 55	19, 29, 50, 67	0
1	C	467/492 (94%)	0.17	17 (3%) 46 49	17, 28, 61, 86	0
1	D	463/492 (94%)	0.38	37 (7%) 20 22	18, 32, 76, 101	0
1	E	462/492 (93%)	0.30	20 (4%) 40 42	21, 31, 55, 80	0
1	F	466/492 (94%)	0.58	42 (9%) 17 18	23, 34, 80, 122	0
All	All	2779/2952 (94%)	0.30	143 (5%) 34 35	17, 31, 61, 122	0

All (143) RSRZ outliers are listed below:

Mol	Chain	Res	Type	RSRZ
1	D	437	LEU	5.6
1	F	379	ASP	5.5
1	E	268	PRO	5.2
1	B	-1	SER	5.0
1	F	438	VAL	4.9
1	E	383	LEU	4.6
1	A	383	LEU	4.5
1	B	263	PRO	4.4
1	F	0	ASN	4.3
1	F	378	GLY	4.2
1	E	-1	SER	4.2
1	C	384	ALA	4.2
1	C	430	LEU	4.1
1	A	268	PRO	4.1
1	F	437	LEU	4.1
1	E	376	VAL	4.1
1	F	384	ALA	4.1
1	F	422	ILE	3.9
1	E	270	ASN	3.8

Continued on next page...

Continued from previous page...

Mol	Chain	Res	Type	RSRZ
1	F	420	LEU	3.8
1	A	378	GLY	3.7
1	D	430	LEU	3.7
1	F	377	PHE	3.7
1	D	269	GLU	3.7
1	A	270	ASN	3.7
1	E	438	VAL	3.6
1	F	425	GLU	3.5
1	F	69	TYR	3.5
1	D	377	PHE	3.5
1	F	433	PHE	3.5
1	F	429	LEU	3.5
1	C	263	PRO	3.5
1	B	375	ALA	3.4
1	E	384	ALA	3.4
1	F	439	ASN	3.4
1	D	434	ASN	3.4
1	D	358	TYR	3.3
1	C	429	LEU	3.2
1	E	439	ASN	3.2
1	A	68	TYR	3.2
1	D	427	GLY	3.2
1	D	443	ILE	3.2
1	F	358	TYR	3.2
1	F	418	LEU	3.2
1	F	436	GLY	3.2
1	C	379	ASP	3.2
1	F	430	LEU	3.1
1	B	69	TYR	3.1
1	D	268	PRO	3.1
1	B	384	ALA	3.1
1	C	470	LYS	3.0
1	F	434	ASN	3.0
1	F	470	LYS	3.0
1	F	268	PRO	3.0
1	C	-1	SER	2.9
1	A	439	ASN	2.9
1	F	363	LEU	2.9
1	F	432	ASP	2.9
1	A	65	GLY	2.9
1	E	264	LYS	2.9
1	F	442	ALA	2.9

Continued on next page...

Continued from previous page...

Mol	Chain	Res	Type	RSRZ
1	F	421	GLU	2.9
1	F	376	VAL	2.9
1	D	441	LYS	2.9
1	C	377	PHE	2.8
1	F	427	GLY	2.8
1	A	384	ALA	2.8
1	D	68	TYR	2.8
1	A	438	VAL	2.8
1	D	438	VAL	2.8
1	D	267	GLN	2.8
1	F	446	LEU	2.8
1	B	269	GLU	2.8
1	D	439	ASN	2.7
1	F	68	TYR	2.7
1	D	270	ASN	2.7
1	E	263	PRO	2.7
1	F	266	GLY	2.7
1	C	268	PRO	2.7
1	D	442	ALA	2.6
1	F	443	ILE	2.6
1	C	265	LYS	2.6
1	D	385	PRO	2.6
1	D	428	LYS	2.6
1	F	424	LYS	2.6
1	F	366	LEU	2.6
1	A	-1	SER	2.6
1	D	433	PHE	2.6
1	D	426	HIS	2.6
1	E	269	GLU	2.6
1	B	422	ILE	2.5
1	D	363	LEU	2.5
1	D	264	LYS	2.5
1	A	418	LEU	2.5
1	C	262	PRO	2.4
1	F	262	PRO	2.4
1	E	430	LEU	2.4
1	D	281	PHE	2.4
1	D	266	GLY	2.4
1	C	68	TYR	2.4
1	F	426	HIS	2.3
1	D	353	LEU	2.3
1	D	429	LEU	2.3

Continued on next page...

Continued from previous page...

Mol	Chain	Res	Type	RSRZ
1	D	432	ASP	2.3
1	D	164	THR	2.3
1	D	265	LYS	2.3
1	E	422	ILE	2.3
1	D	132	GLY	2.2
1	B	262	PRO	2.2
1	D	262	PRO	2.2
1	C	439	ASN	2.2
1	D	366	LEU	2.2
1	E	418	LEU	2.2
1	E	437	LEU	2.2
1	F	270	ASN	2.2
1	F	464	VAL	2.2
1	B	439	ASN	2.2
1	B	68	TYR	2.2
1	A	263	PRO	2.2
1	D	263	PRO	2.2
1	D	376	VAL	2.2
1	F	66	ASN	2.2
1	F	355	LEU	2.2
1	A	426	HIS	2.2
1	B	425	GLU	2.1
1	E	424	LYS	2.1
1	F	431	LYS	2.1
1	D	271	ALA	2.1
1	C	431	LYS	2.1
1	E	143	GLY	2.1
1	C	464	VAL	2.1
1	D	420	LEU	2.1
1	D	422	ILE	2.1
1	E	443	ILE	2.1
1	E	419	THR	2.1
1	B	353	LEU	2.0
1	B	437	LEU	2.0
1	F	359	LYS	2.0
1	B	164	THR	2.0
1	C	422	ILE	2.0
1	E	0	ASN	2.0
1	F	164	THR	2.0
1	C	438	VAL	2.0

6.2 Non-standard residues in protein, DNA, RNA chains [i](#)

In the following table, the Atoms column lists the number of modelled atoms in the group and the number defined in the chemical component dictionary. The B-factors column lists the minimum, median, 95th percentile and maximum values of B factors of atoms in the group. The column labelled 'Q< 0.9' lists the number of atoms with occupancy less than 0.9.

Mol	Type	Chain	Res	Atoms	RSCC	RSR	B-factors(Å ²)	Q<0.9
1	LLP	C	244	24/25	0.95	0.08	20,26,29,31	0
1	LLP	B	244	24/25	0.96	0.08	23,26,30,30	0
1	LLP	A	244	24/25	0.96	0.07	20,24,28,30	0
1	LLP	D	244	24/25	0.96	0.07	23,27,32,35	0
1	LLP	E	244	24/25	0.96	0.08	24,27,31,33	0
1	LLP	F	244	24/25	0.96	0.08	26,29,33,35	0

6.3 Carbohydrates [i](#)

There are no oligosaccharides in this entry.

6.4 Ligands [i](#)

There are no ligands in this entry.

6.5 Other polymers [i](#)

There are no such residues in this entry.