



Full wwPDB X-ray Structure Validation Report

Mar 31, 2026 – 12:15 PM EDT

PDB ID : 9YBZ / pdb_00009ybz
Title : CRYSTAL STRUCTURE OF THE A149T VARIANT OF SERINE HYDROXYMETHYLTRANSFERASE 8 FROM SOYBEAN CULTIVAR ESSEX IN COMPLEX WITH PLP
Authors : Beamer, L.J.; Samarakoon, V.; Owuocha, L.F.
Deposited on : 2025-09-17
Resolution : 2.28 Å(reported)

This is a Full wwPDB X-ray Structure Validation Report for a publicly released PDB entry.

We welcome your comments at validation@mail.wwpdb.org

A user guide is available at

<https://www.wwpdb.org/validation/2017/XrayValidationReportHelp>

with specific help available everywhere you see the  symbol.

The types of validation reports are described at

<http://www.wwpdb.org/validation/2017/FAQs#types>.

The following versions of software and data (see [references](#) ) were used in the production of this report:

MolProbity : 4-5-2 with Phenix2.0
Mogul : 2022.3.0, CSD as543be (2022)
Xtrriage (Phenix) : 2.0
EDS : 3.0
Percentile statistics : 20231227.v01 (using entries in the PDB archive December 27th 2023)
CCP4 : 9.0.010 (Gargrove)
Density-Fitness : 1.0.12
Ideal geometry (proteins) : Engh & Huber (2001)
Ideal geometry (DNA, RNA) : Parkinson et al. (1996)
Validation Pipeline (wwPDB-VP) : 2.48.1

1 Overall quality at a glance

The following experimental techniques were used to determine the structure:

X-RAY DIFFRACTION

The reported resolution of this entry is 2.28 Å.

Percentile scores (ranging between 0-100) for global validation metrics of the entry are shown in the following graphic. The table shows the number of entries on which the scores are based.

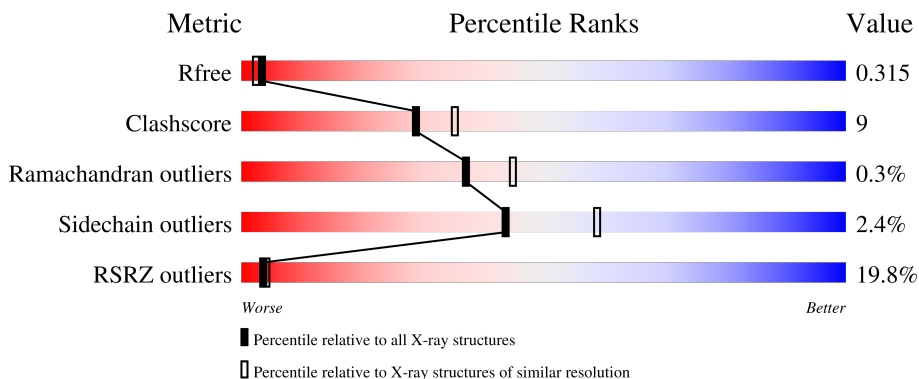

Metric	Whole archive (#Entries)	Similar resolution (#Entries, resolution range(Å))
R_{free}	164625	8487 (2.30-2.26)
Clashscore	180529	9437 (2.30-2.26)
Ramachandran outliers	177936	9341 (2.30-2.26)
Sidechain outliers	177891	9342 (2.30-2.26)
RSRZ outliers	164620	8487 (2.30-2.26)

The table below summarises the geometric issues observed across the polymeric chains and their fit to the electron density. The red, orange, yellow and green segments of the lower bar indicate the fraction of residues that contain outliers for ≥ 3 , 2, 1 and 0 types of geometric quality criteria respectively. A grey segment represents the fraction of residues that are not modelled. The numeric value for each fraction is indicated below the corresponding segment, with a dot representing fractions $\leq 5\%$. The upper red bar (where present) indicates the fraction of residues that have poor fit to the electron density. The numeric value is given above the bar.

Mol	Chain	Length	Quality of chain
1	A	492	 13% 74% 18% • 6%
1	B	492	 10% 75% 17% • 7%
1	C	492	 10% 75% 17% • 7%
1	D	492	 12% 76% 18% • 6%
1	E	492	 13% 79% 14% • 6%

Continued on next page...

Continued from previous page...

Mol	Chain	Length	Quality of chain
1	F	492	 <p>53% 74% 16% • 9%</p>

2 Entry composition [i](#)

There are 2 unique types of molecules in this entry. The entry contains 20214 atoms, of which 0 are hydrogens and 0 are deuteriums.

In the tables below, the ZeroOcc column contains the number of atoms modelled with zero occupancy, the AltConf column contains the number of residues with at least one atom in alternate conformation and the Trace column contains the number of residues modelled with at most 2 atoms.

- Molecule 1 is a protein called Serine hydroxymethyltransferase.

Mol	Chain	Residues	Atoms						ZeroOcc	AltConf	Trace
			Total	C	N	O	P	S			
1	A	462	3414	2159	588	649	1	17	0	0	0
1	B	459	3409	2163	585	644	1	16	0	0	0
1	C	460	3434	2180	584	652	1	17	0	0	0
1	D	463	3419	2172	580	649	1	17	0	0	0
1	E	461	3367	2137	578	635	1	16	0	0	0
1	F	450	2972	1847	527	583	1	14	0	0	0

There are 132 discrepancies between the modelled and reference sequences:

Chain	Residue	Modelled	Actual	Comment	Reference
A	-20	MET	-	expression tag	UNP K4FZF8
A	-19	GLY	-	expression tag	UNP K4FZF8
A	-18	SER	-	expression tag	UNP K4FZF8
A	-17	SER	-	expression tag	UNP K4FZF8
A	-16	HIS	-	expression tag	UNP K4FZF8
A	-15	HIS	-	expression tag	UNP K4FZF8
A	-14	HIS	-	expression tag	UNP K4FZF8
A	-13	HIS	-	expression tag	UNP K4FZF8
A	-12	HIS	-	expression tag	UNP K4FZF8
A	-11	HIS	-	expression tag	UNP K4FZF8
A	-10	HIS	-	expression tag	UNP K4FZF8
A	-9	SER	-	expression tag	UNP K4FZF8
A	-8	SER	-	expression tag	UNP K4FZF8
A	-7	GLY	-	expression tag	UNP K4FZF8
A	-6	LEU	-	expression tag	UNP K4FZF8
A	-5	VAL	-	expression tag	UNP K4FZF8
A	-4	PRO	-	expression tag	UNP K4FZF8

Continued on next page...

Continued from previous page...

Chain	Residue	Modelled	Actual	Comment	Reference
A	-3	ARG	-	expression tag	UNP K4FZF8
A	-2	GLY	-	expression tag	UNP K4FZF8
A	-1	SER	-	expression tag	UNP K4FZF8
A	0	ASN	-	expression tag	UNP K4FZF8
A	149	THR	ALA	engineered mutation	UNP K4FZF8
B	-20	MET	-	expression tag	UNP K4FZF8
B	-19	GLY	-	expression tag	UNP K4FZF8
B	-18	SER	-	expression tag	UNP K4FZF8
B	-17	SER	-	expression tag	UNP K4FZF8
B	-16	HIS	-	expression tag	UNP K4FZF8
B	-15	HIS	-	expression tag	UNP K4FZF8
B	-14	HIS	-	expression tag	UNP K4FZF8
B	-13	HIS	-	expression tag	UNP K4FZF8
B	-12	HIS	-	expression tag	UNP K4FZF8
B	-11	HIS	-	expression tag	UNP K4FZF8
B	-10	HIS	-	expression tag	UNP K4FZF8
B	-9	SER	-	expression tag	UNP K4FZF8
B	-8	SER	-	expression tag	UNP K4FZF8
B	-7	GLY	-	expression tag	UNP K4FZF8
B	-6	LEU	-	expression tag	UNP K4FZF8
B	-5	VAL	-	expression tag	UNP K4FZF8
B	-4	PRO	-	expression tag	UNP K4FZF8
B	-3	ARG	-	expression tag	UNP K4FZF8
B	-2	GLY	-	expression tag	UNP K4FZF8
B	-1	SER	-	expression tag	UNP K4FZF8
B	0	ASN	-	expression tag	UNP K4FZF8
B	149	THR	ALA	engineered mutation	UNP K4FZF8
C	-20	MET	-	expression tag	UNP K4FZF8
C	-19	GLY	-	expression tag	UNP K4FZF8
C	-18	SER	-	expression tag	UNP K4FZF8
C	-17	SER	-	expression tag	UNP K4FZF8
C	-16	HIS	-	expression tag	UNP K4FZF8
C	-15	HIS	-	expression tag	UNP K4FZF8
C	-14	HIS	-	expression tag	UNP K4FZF8
C	-13	HIS	-	expression tag	UNP K4FZF8
C	-12	HIS	-	expression tag	UNP K4FZF8
C	-11	HIS	-	expression tag	UNP K4FZF8
C	-10	HIS	-	expression tag	UNP K4FZF8
C	-9	SER	-	expression tag	UNP K4FZF8
C	-8	SER	-	expression tag	UNP K4FZF8
C	-7	GLY	-	expression tag	UNP K4FZF8
C	-6	LEU	-	expression tag	UNP K4FZF8

Continued on next page...

Continued from previous page...

Chain	Residue	Modelled	Actual	Comment	Reference
C	-5	VAL	-	expression tag	UNP K4FZF8
C	-4	PRO	-	expression tag	UNP K4FZF8
C	-3	ARG	-	expression tag	UNP K4FZF8
C	-2	GLY	-	expression tag	UNP K4FZF8
C	-1	SER	-	expression tag	UNP K4FZF8
C	0	ASN	-	expression tag	UNP K4FZF8
C	149	THR	ALA	engineered mutation	UNP K4FZF8
D	-20	MET	-	expression tag	UNP K4FZF8
D	-19	GLY	-	expression tag	UNP K4FZF8
D	-18	SER	-	expression tag	UNP K4FZF8
D	-17	SER	-	expression tag	UNP K4FZF8
D	-16	HIS	-	expression tag	UNP K4FZF8
D	-15	HIS	-	expression tag	UNP K4FZF8
D	-14	HIS	-	expression tag	UNP K4FZF8
D	-13	HIS	-	expression tag	UNP K4FZF8
D	-12	HIS	-	expression tag	UNP K4FZF8
D	-11	HIS	-	expression tag	UNP K4FZF8
D	-10	HIS	-	expression tag	UNP K4FZF8
D	-9	SER	-	expression tag	UNP K4FZF8
D	-8	SER	-	expression tag	UNP K4FZF8
D	-7	GLY	-	expression tag	UNP K4FZF8
D	-6	LEU	-	expression tag	UNP K4FZF8
D	-5	VAL	-	expression tag	UNP K4FZF8
D	-4	PRO	-	expression tag	UNP K4FZF8
D	-3	ARG	-	expression tag	UNP K4FZF8
D	-2	GLY	-	expression tag	UNP K4FZF8
D	-1	SER	-	expression tag	UNP K4FZF8
D	0	ASN	-	expression tag	UNP K4FZF8
D	149	THR	ALA	engineered mutation	UNP K4FZF8
E	-20	MET	-	expression tag	UNP K4FZF8
E	-19	GLY	-	expression tag	UNP K4FZF8
E	-18	SER	-	expression tag	UNP K4FZF8
E	-17	SER	-	expression tag	UNP K4FZF8
E	-16	HIS	-	expression tag	UNP K4FZF8
E	-15	HIS	-	expression tag	UNP K4FZF8
E	-14	HIS	-	expression tag	UNP K4FZF8
E	-13	HIS	-	expression tag	UNP K4FZF8
E	-12	HIS	-	expression tag	UNP K4FZF8
E	-11	HIS	-	expression tag	UNP K4FZF8
E	-10	HIS	-	expression tag	UNP K4FZF8
E	-9	SER	-	expression tag	UNP K4FZF8
E	-8	SER	-	expression tag	UNP K4FZF8

Continued on next page...

Continued from previous page...

Chain	Residue	Modelled	Actual	Comment	Reference
E	-7	GLY	-	expression tag	UNP K4FZF8
E	-6	LEU	-	expression tag	UNP K4FZF8
E	-5	VAL	-	expression tag	UNP K4FZF8
E	-4	PRO	-	expression tag	UNP K4FZF8
E	-3	ARG	-	expression tag	UNP K4FZF8
E	-2	GLY	-	expression tag	UNP K4FZF8
E	-1	SER	-	expression tag	UNP K4FZF8
E	0	ASN	-	expression tag	UNP K4FZF8
E	149	THR	ALA	engineered mutation	UNP K4FZF8
F	-20	MET	-	expression tag	UNP K4FZF8
F	-19	GLY	-	expression tag	UNP K4FZF8
F	-18	SER	-	expression tag	UNP K4FZF8
F	-17	SER	-	expression tag	UNP K4FZF8
F	-16	HIS	-	expression tag	UNP K4FZF8
F	-15	HIS	-	expression tag	UNP K4FZF8
F	-14	HIS	-	expression tag	UNP K4FZF8
F	-13	HIS	-	expression tag	UNP K4FZF8
F	-12	HIS	-	expression tag	UNP K4FZF8
F	-11	HIS	-	expression tag	UNP K4FZF8
F	-10	HIS	-	expression tag	UNP K4FZF8
F	-9	SER	-	expression tag	UNP K4FZF8
F	-8	SER	-	expression tag	UNP K4FZF8
F	-7	GLY	-	expression tag	UNP K4FZF8
F	-6	LEU	-	expression tag	UNP K4FZF8
F	-5	VAL	-	expression tag	UNP K4FZF8
F	-4	PRO	-	expression tag	UNP K4FZF8
F	-3	ARG	-	expression tag	UNP K4FZF8
F	-2	GLY	-	expression tag	UNP K4FZF8
F	-1	SER	-	expression tag	UNP K4FZF8
F	0	ASN	-	expression tag	UNP K4FZF8
F	149	THR	ALA	engineered mutation	UNP K4FZF8

- Molecule 2 is water.

Mol	Chain	Residues	Atoms	ZeroOcc	AltConf
2	A	34	Total O 34 34	0	0
2	B	44	Total O 44 44	0	0
2	C	32	Total O 32 32	0	0
2	D	51	Total O 51 51	0	0

Continued on next page...

Continued from previous page...

Mol	Chain	Residues	Atoms		ZeroOcc	AltConf
2	E	32	Total	O	0	0
			32	32		
2	F	6	Total	O	0	0
			6	6		

3 Residue-property plots

These plots are drawn for all protein, RNA, DNA and oligosaccharide chains in the entry. The first graphic for a chain summarises the proportions of the various outlier classes displayed in the second graphic. The second graphic shows the sequence view annotated by issues in geometry and electron density. Residues are color-coded according to the number of geometric quality criteria for which they contain at least one outlier: green = 0, yellow = 1, orange = 2 and red = 3 or more. A red dot above a residue indicates a poor fit to the electron density ($RSRZ > 2$). Stretches of 2 or more consecutive residues without any outlier are shown as a green connector. Residues present in the sample, but not in the model, are shown in grey.

- Molecule 1: Serine hydroxymethyltransferase

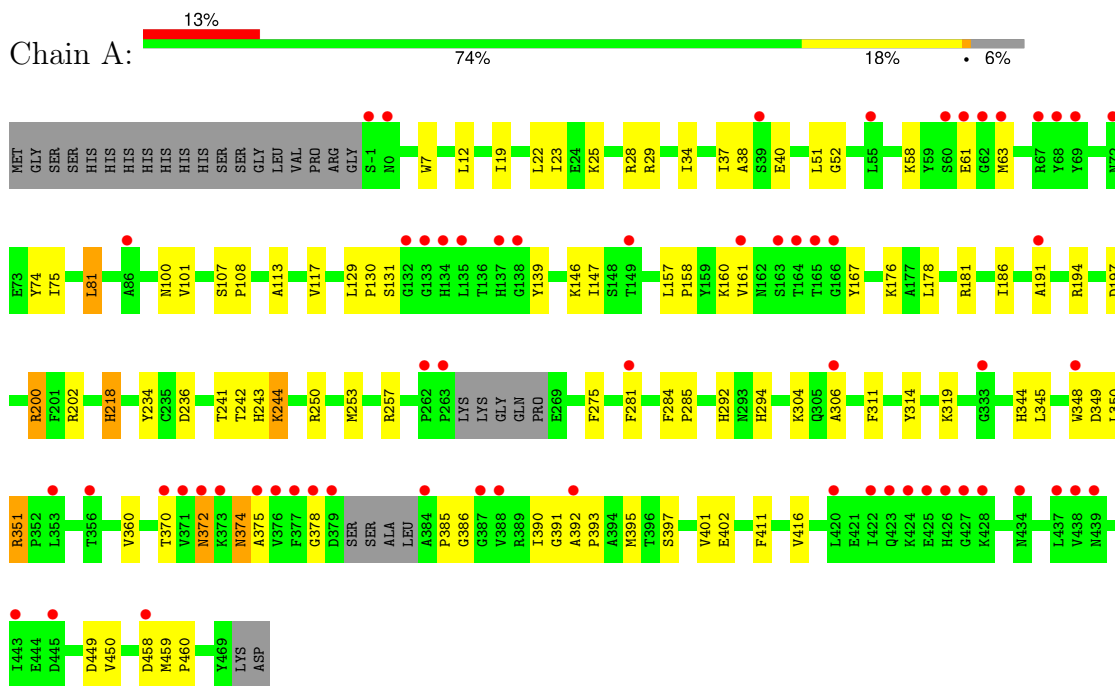

- Molecule 1: Serine hydroxymethyltransferase

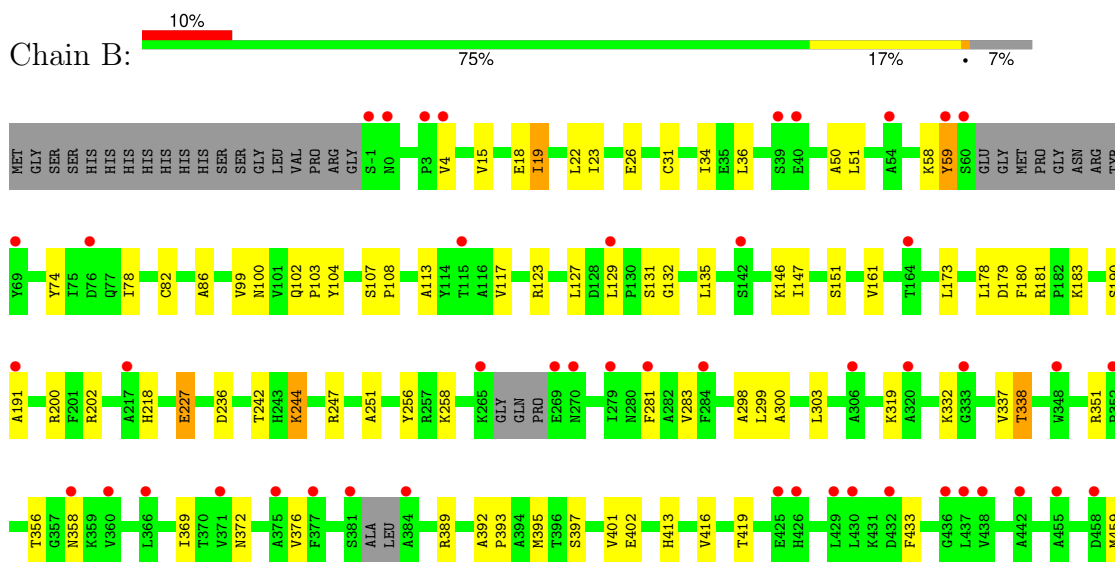



- Molecule 1: Serine hydroxymethyltransferase

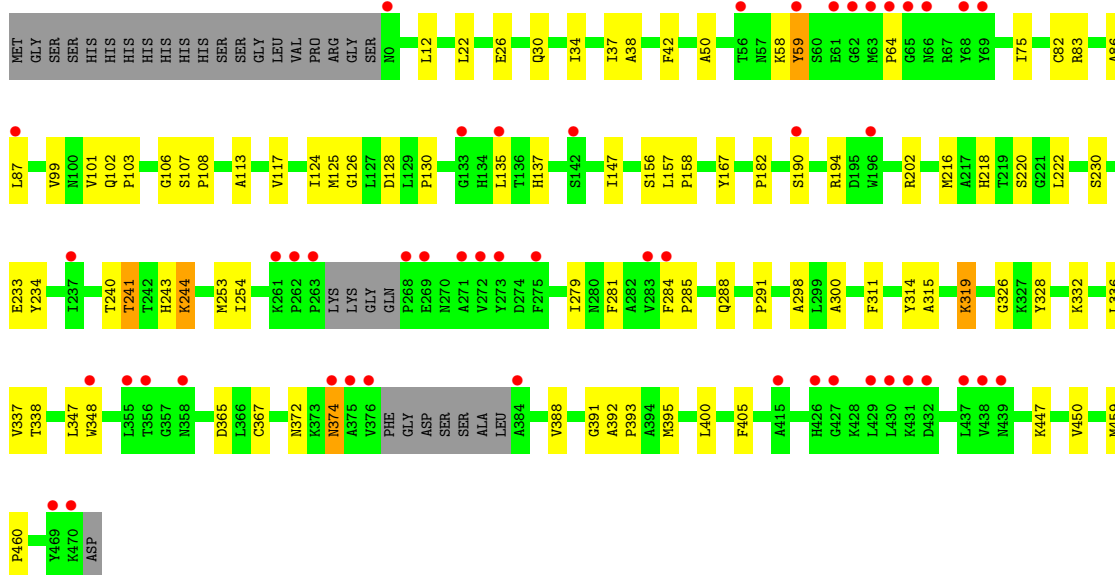
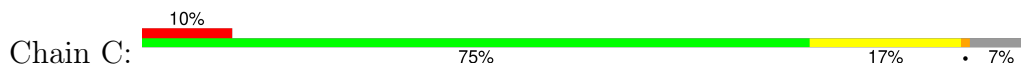

- Molecule 1: Serine hydroxymethyltransferase

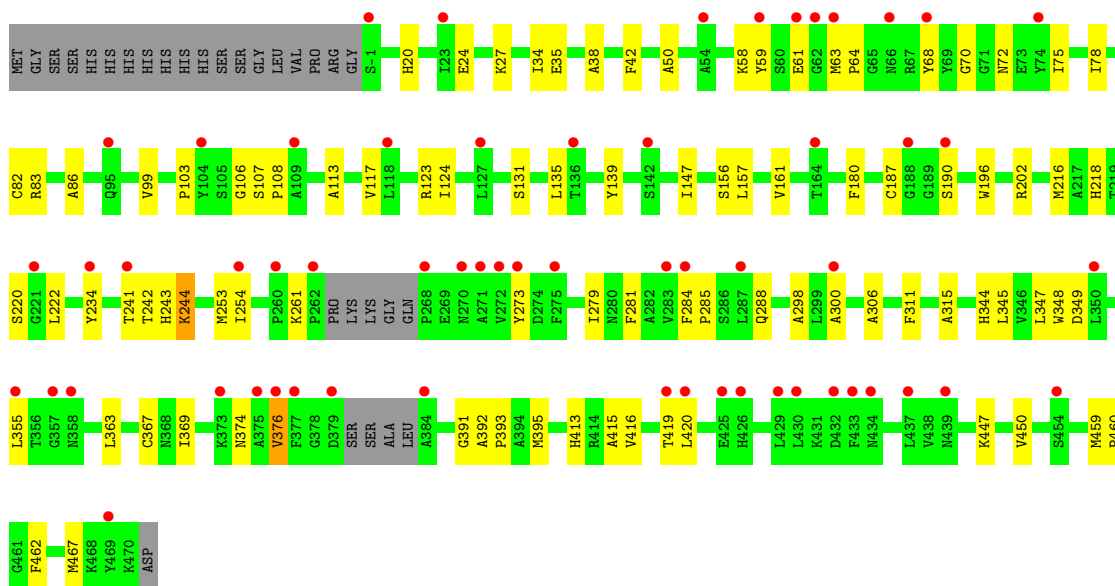
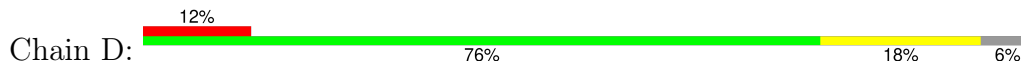

- Molecule 1: Serine hydroxymethyltransferase

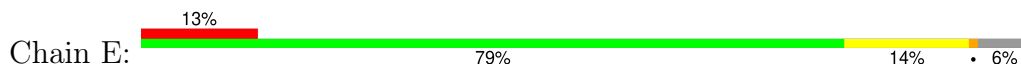

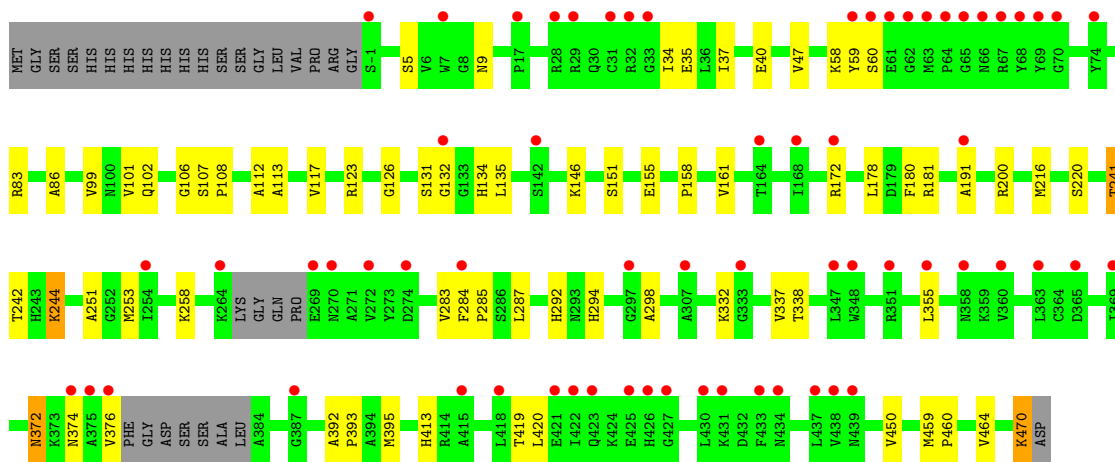

• Molecule 1: Serine hydroxymethyltransferase

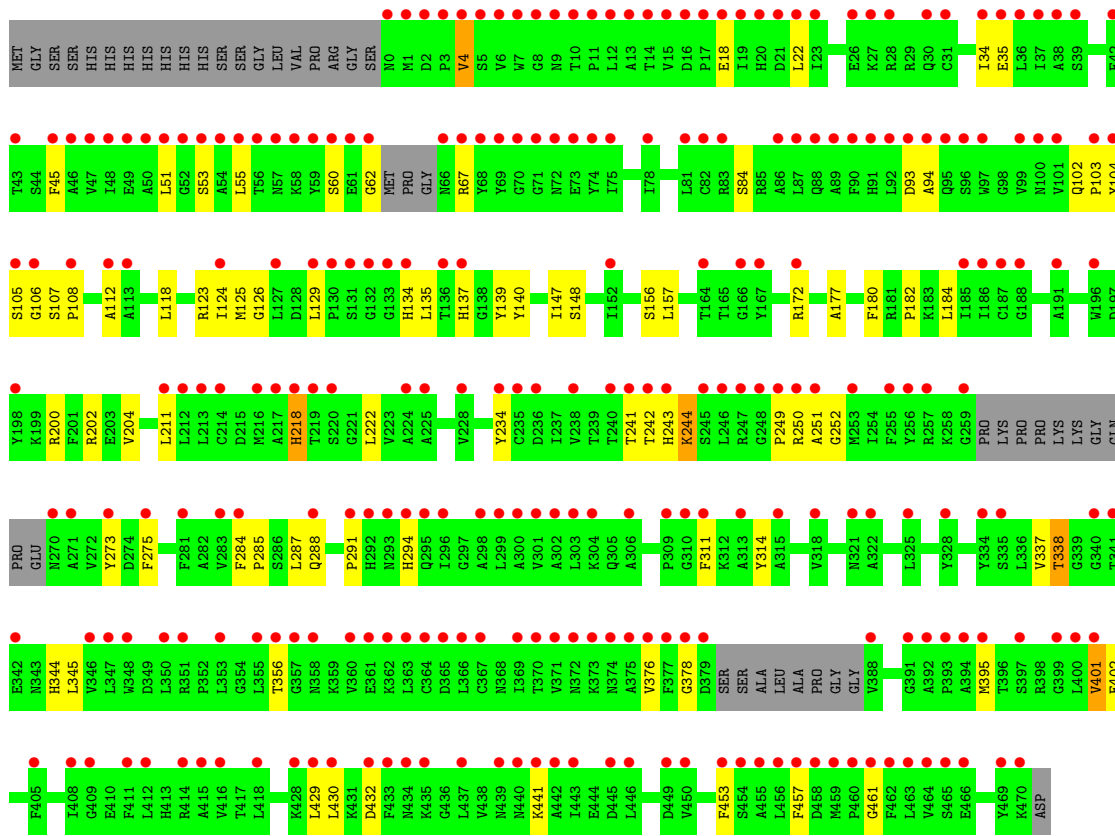
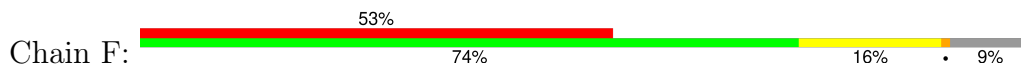

4 Data and refinement statistics

Property	Value	Source
Space group	P 31 2 1	Depositor
Cell constants a, b, c, α , β , γ	174.32Å 174.32Å 184.21Å 90.00° 90.00° 120.00°	Depositor
Resolution (Å)	48.54 – 2.28 48.54 – 2.28	Depositor EDS
% Data completeness (in resolution range)	98.8 (48.54-2.28) 98.9 (48.54-2.28)	Depositor EDS
R_{merge}	0.18	Depositor
R_{sym}	(Not available)	Depositor
$\langle I/\sigma(I) \rangle$ ¹	2.20 (at 2.29Å)	Xtrriage
Refinement program	PHENIX 1.21.2_5419	Depositor
R, R_{free}	0.272 , 0.313 0.276 , 0.315	Depositor DCC
R_{free} test set	7353 reflections (5.00%)	wwPDB-VP
Wilson B-factor (Å ²)	34.8	Xtrriage
Anisotropy	0.637	Xtrriage
Bulk solvent k_{sol} (e/Å ³), B_{sol} (Å ²)	0.29 , 41.6	EDS
L-test for twinning ²	$\langle L \rangle = 0.51$, $\langle L^2 \rangle = 0.35$	Xtrriage
Estimated twinning fraction	0.010 for -h,-k,l	Xtrriage
F_o, F_c correlation	0.92	EDS
Total number of atoms	20214	wwPDB-VP
Average B, all atoms (Å ²)	51.0	wwPDB-VP

Xtrriage's analysis on translational NCS is as follows: *The analyses of the Patterson function reveals a significant off-origin peak that is 33.41 % of the origin peak, indicating pseudo-translational symmetry. The chance of finding a peak of this or larger height randomly in a structure without pseudo-translational symmetry is equal to 8.0390e-04. The detected translational NCS is most likely also responsible for the elevated intensity ratio.*

¹Intensities estimated from amplitudes.

²Theoretical values of $\langle |L| \rangle$, $\langle L^2 \rangle$ for acentric reflections are 0.5, 0.333 respectively for untwinned datasets, and 0.375, 0.2 for perfectly twinned datasets.

5 Model quality [i](#)

5.1 Standard geometry [i](#)

Bond lengths and bond angles in the following residue types are not validated in this section: LLP

The Z score for a bond length (or angle) is the number of standard deviations the observed value is removed from the expected value. A bond length (or angle) with $|Z| > 5$ is considered an outlier worth inspection. RMSZ is the root-mean-square of all Z scores of the bond lengths (or angles).

Mol	Chain	Bond lengths		Bond angles	
		RMSZ	# Z >5	RMSZ	# Z >5
1	A	0.38	0/3468	0.61	0/4720
1	B	0.37	0/3461	0.61	0/4706
1	C	0.34	0/3490	0.57	0/4746
1	D	0.36	0/3472	0.59	0/4722
1	E	0.38	0/3418	0.60	0/4657
1	F	0.34	0/3003	0.61	0/4106
All	All	0.36	0/20312	0.60	0/27657

There are no bond length outliers.

There are no bond angle outliers.

There are no chirality outliers.

There are no planarity outliers.

5.2 Too-close contacts [i](#)

In the following table, the Non-H and H(model) columns list the number of non-hydrogen atoms and hydrogen atoms in the chain respectively. The H(added) column lists the number of hydrogen atoms added and optimized by MolProbity. The Clashes column lists the number of clashes within the asymmetric unit, whereas Symm-Clashes lists symmetry-related clashes.

Mol	Chain	Non-H	H(model)	H(added)	Clashes	Symm-Clashes
1	A	3414	0	3144	75	0
1	B	3409	0	3178	62	0
1	C	3434	0	3216	61	0
1	D	3419	0	3173	59	0
1	E	3367	0	3109	46	0
1	F	2972	0	2362	56	0
2	A	34	0	0	0	0

Continued on next page...

Continued from previous page...

Mol	Chain	Non-H	H(model)	H(added)	Clashes	Symm-Clashes
2	B	44	0	0	0	0
2	C	32	0	0	0	0
2	D	51	0	0	3	0
2	E	32	0	0	0	0
2	F	6	0	0	0	0
All	All	20214	0	18182	330	0

The all-atom clashscore is defined as the number of clashes found per 1000 atoms (including hydrogen atoms). The all-atom clashscore for this structure is 9.

All (330) close contacts within the same asymmetric unit are listed below, sorted by their clash magnitude.

Atom-1	Atom-2	Interatomic distance (Å)	Clash overlap (Å)
1:C:125:MET:HE2	1:C:182:PRO:HG3	1.40	1.04
1:A:243:HIS:HE2	1:B:59:TYR:HE1	1.13	0.93
1:C:106:GLY:HA3	1:C:241:THR:HG22	1.56	0.86
1:D:34:ILE:HA	1:D:395:MET:HE2	1.58	0.84
1:E:37:ILE:HG23	1:E:372:ASN:HD21	1.44	0.82
1:F:125:MET:HE2	1:F:182:PRO:HG3	1.60	0.82
1:E:172:ARG:HH11	1:F:172:ARG:HH22	1.27	0.81
1:F:106:GLY:HA3	1:F:241:THR:HG22	1.62	0.81
1:C:64:PRO:HG2	1:C:83:ARG:HH12	1.50	0.77
1:A:34:ILE:HA	1:A:395:MET:HE2	1.66	0.76
1:A:34:ILE:HG13	1:A:450:VAL:HG13	1.65	0.76
1:A:374:ASN:HD22	1:A:375:ALA:H	1.32	0.75
1:A:74:TYR:HB2	1:B:26:GLU:HG2	1.67	0.75
1:F:62:GLY:HA3	1:F:67:ARG:HA	1.71	0.71
1:B:34:ILE:HA	1:B:395:MET:HE2	1.71	0.71
1:A:250:ARG:HH22	1:B:58:LYS:C	1.99	0.71
1:E:35:GLU:H	1:E:395:MET:HE2	1.56	0.70
1:C:107:SER:HB2	1:C:108:PRO:HD3	1.74	0.70
1:E:106:GLY:HA3	1:E:244:LLP:H5'1	1.73	0.69
1:E:178:LEU:O	1:E:181:ARG:HD3	1.95	0.67
1:A:130:PRO:HB2	1:A:378:GLY:HA2	1.77	0.67
1:D:58:LYS:HG2	1:D:75:ILE:HG13	1.77	0.66
1:B:372:ASN:HD21	1:B:389:ARG:HE	1.42	0.66
1:D:131:SER:HB3	1:D:161:VAL:HG13	1.77	0.66
1:D:107:SER:HB2	1:D:108:PRO:HD3	1.78	0.65
1:F:273:TYR:HD2	1:F:275:PHE:HE2	1.44	0.65
1:A:241:THR:HG21	1:A:244:LLP:HG2	1.78	0.65
1:A:52:GLY:HA2	1:B:51:LEU:HD23	1.79	0.65

Continued on next page...

Continued from previous page...

Atom-1	Atom-2	Interatomic distance (Å)	Clash overlap (Å)
1:B:351:ARG:HD3	1:B:376:VAL:HG21	1.80	0.64
1:E:241:THR:HG21	1:E:244:LLP:HE3	1.80	0.64
1:F:104:TYR:H	1:F:288:GLN:HE22	1.44	0.64
1:E:146:LYS:HD3	1:E:151:SER:O	1.98	0.64
1:A:107:SER:HB2	1:A:108:PRO:HD3	1.81	0.63
1:F:241:THR:HB	1:F:243:HIS:CE1	2.33	0.63
1:E:191:ALA:HB2	1:E:374:ASN:ND2	2.13	0.63
1:B:131:SER:HB3	1:B:161:VAL:HG13	1.79	0.63
1:F:126:GLY:HA3	1:F:137:HIS:HB3	1.81	0.62
1:B:146:LYS:HD3	1:B:151:SER:O	2.00	0.62
1:C:58:LYS:HG2	1:C:75:ILE:HG13	1.81	0.61
1:E:34:ILE:HG13	1:E:450:VAL:HG13	1.81	0.61
1:F:34:ILE:HA	1:F:395:MET:HE2	1.83	0.61
1:D:241:THR:HB	1:D:243:HIS:CE1	2.35	0.61
1:B:459:MET:SD	1:B:460:PRO:HD2	2.40	0.61
1:E:191:ALA:HB2	1:E:374:ASN:HD22	1.66	0.61
1:F:107:SER:HB2	1:F:108:PRO:HD3	1.83	0.60
1:F:125:MET:HG2	1:F:157:LEU:O	2.00	0.60
1:E:34:ILE:HA	1:E:395:MET:HE2	1.82	0.60
1:F:241:THR:HG21	1:F:244:LLP:H5'1	1.82	0.60
1:A:37:ILE:HD12	1:A:372:ASN:ND2	2.16	0.60
1:C:26:GLU:HG3	1:C:30:GLN:HE21	1.67	0.60
1:C:241:THR:HG21	1:C:244:LLP:H5'2	1.81	0.60
1:C:395:MET:HB3	1:C:400:LEU:HD22	1.82	0.60
1:F:273:TYR:HD2	1:F:275:PHE:CE2	2.20	0.60
1:D:106:GLY:HA3	1:D:241:THR:HG22	1.84	0.59
1:E:337:VAL:HG12	1:E:338:THR:HG23	1.84	0.59
1:E:58:LYS:HE3	1:E:59:TYR:O	2.02	0.59
1:E:459:MET:SD	1:E:460:PRO:HD2	2.43	0.59
1:F:125:MET:HE1	1:F:177:ALA:HA	1.85	0.59
1:F:311:PHE:O	1:F:314:TYR:HB3	2.04	0.58
1:D:34:ILE:HA	1:D:395:MET:CE	2.32	0.57
1:A:178:LEU:O	1:A:181:ARG:HD3	2.04	0.57
1:C:22:LEU:HD23	1:D:78:ILE:HG13	1.85	0.57
1:C:348:TRP:HB3	1:C:388:VAL:HG23	1.85	0.57
1:F:243:HIS:CG	1:F:250:ARG:HA	2.40	0.57
1:E:47:VAL:HG13	1:E:298:ALA:HB1	1.86	0.57
1:A:351:ARG:HD3	1:A:386:GLY:HA3	1.86	0.57
1:C:106:GLY:CA	1:C:241:THR:HG22	2.32	0.57
1:F:453:PHE:CE1	1:F:457:PHE:HE2	2.23	0.57
1:A:241:THR:CG2	1:A:244:LLP:HG2	2.35	0.56

Continued on next page...

Continued from previous page...

Atom-1	Atom-2	Interatomic distance (Å)	Clash overlap (Å)
1:E:86:ALA:HB3	1:E:99:VAL:HG11	1.88	0.56
1:C:38:ALA:HA	1:C:391:GLY:HA3	1.86	0.56
1:D:222:LEU:HD23	1:D:315:ALA:HB1	1.88	0.56
1:F:35:GLU:H	1:F:395:MET:HE2	1.71	0.56
1:F:200:ARG:O	1:F:204:VAL:HG23	2.07	0.55
1:B:337:VAL:HG12	1:B:338:THR:HG23	1.86	0.55
1:E:172:ARG:NH1	1:F:172:ARG:HH22	2.02	0.55
1:E:155:GLU:HB3	1:F:123:ARG:HH21	1.72	0.55
1:B:102:GLN:HB2	1:B:283:VAL:HG11	1.89	0.55
1:F:337:VAL:O	1:F:338:THR:HG22	2.07	0.54
1:D:392:ALA:N	1:D:393:PRO:HD3	2.22	0.54
1:A:374:ASN:O	1:A:385:PRO:HB2	2.07	0.54
1:A:459:MET:SD	1:A:460:PRO:HD2	2.47	0.54
1:C:216:MET:HG3	1:C:220:SER:HB3	1.87	0.54
1:F:124:ILE:CD1	1:F:184:LEU:HB3	2.38	0.54
1:B:82:CYS:HB2	1:B:300:ALA:HB2	1.88	0.54
1:A:242:THR:HG22	1:A:253:MET:HE2	1.89	0.54
1:B:356:THR:HG22	1:B:358:ASN:H	1.72	0.54
1:C:128:ASP:CG	1:C:130:PRO:HD2	2.33	0.54
1:D:82:CYS:HB2	1:D:300:ALA:HB2	1.90	0.54
1:F:34:ILE:HA	1:F:395:MET:CE	2.38	0.54
1:A:34:ILE:HG23	1:A:395:MET:HE2	1.90	0.53
1:A:350:LEU:HD22	1:A:360:VAL:HG21	1.90	0.53
1:F:118:LEU:HD11	1:F:124:ILE:HD11	1.90	0.53
1:D:218:HIS:HD2	1:D:244:LLP:O3	1.91	0.53
1:C:37:ILE:HG23	1:C:372:ASN:HD21	1.74	0.53
1:A:241:THR:HG21	1:A:244:LLP:HE3	1.89	0.53
1:A:37:ILE:HB	1:A:40:GLU:HB2	1.91	0.53
1:C:311:PHE:O	1:C:314:TYR:HB3	2.09	0.53
1:B:218:HIS:CD2	1:B:244:LLP:O3	2.62	0.53
1:B:356:THR:HG22	1:B:358:ASN:N	2.23	0.53
1:D:38:ALA:HA	1:D:391:GLY:HA3	1.90	0.53
1:C:125:MET:HG2	1:C:157:LEU:O	2.08	0.52
1:E:332:LYS:HG3	1:E:413:HIS:HD2	1.73	0.52
1:D:35:GLU:H	1:D:395:MET:HE2	1.74	0.52
1:B:107:SER:HB2	1:B:108:PRO:HD3	1.91	0.52
1:D:34:ILE:HG13	1:D:450:VAL:HG13	1.91	0.52
1:A:350:LEU:CD2	1:A:360:VAL:HG21	2.39	0.52
1:A:202:ARG:HB2	1:A:234:TYR:HB3	1.90	0.52
1:C:82:CYS:HB2	1:C:300:ALA:HB2	1.91	0.52
1:D:58:LYS:HE3	1:D:72:ASN:ND2	2.24	0.52

Continued on next page...

Continued from previous page...

Atom-1	Atom-2	Interatomic distance (Å)	Clash overlap (Å)
1:D:459:MET:SD	1:D:460:PRO:HD2	2.50	0.52
1:D:467:MET:HG2	2:D:529:HOH:O	2.09	0.52
1:E:5:SER:HA	1:E:9:ASN:HB2	1.92	0.52
1:D:254:ILE:HG21	1:D:279:ILE:HD12	1.92	0.52
1:C:337:VAL:HG12	1:C:338:THR:HG23	1.91	0.51
1:A:61:GLU:HG2	1:A:284:PHE:CE1	2.44	0.51
1:A:167:TYR:CE1	1:A:194:ARG:HG3	2.46	0.51
1:C:58:LYS:HE3	1:C:59:TYR:O	2.11	0.51
1:D:61:GLU:HB3	1:D:284:PHE:CZ	2.45	0.51
1:D:344:HIS:NE2	1:D:345:LEU:HD23	2.25	0.51
1:B:372:ASN:ND2	1:B:389:ARG:HH21	2.09	0.51
1:D:27:LYS:HE3	1:D:462:PHE:CD2	2.45	0.51
1:F:284:PHE:CD1	1:F:285:PRO:HA	2.45	0.51
1:C:459:MET:SD	1:C:460:PRO:HD2	2.51	0.51
1:F:129:LEU:HD21	1:F:135:LEU:HD22	1.93	0.50
1:A:243:HIS:NE2	1:B:59:TYR:HE1	1.96	0.50
1:F:401:VAL:HG13	1:F:402:GLU:N	2.27	0.50
1:C:281:PHE:CZ	1:D:147:ILE:HD12	2.47	0.50
1:F:134:HIS:CD2	1:F:135:LEU:H	2.29	0.50
1:C:128:ASP:OD2	1:C:130:PRO:HD2	2.12	0.50
1:A:34:ILE:HA	1:A:395:MET:CE	2.39	0.50
1:C:102:GLN:OE1	1:C:291:PRO:HG3	2.11	0.50
1:D:413:HIS:C	1:D:413:HIS:CD2	2.91	0.49
1:A:306:ALA:HA	1:A:311:PHE:CG	2.48	0.49
1:E:355:LEU:HD22	1:E:419:THR:HG22	1.93	0.49
1:E:107:SER:HB2	1:E:108:PRO:HD3	1.94	0.49
1:F:123:ARG:HB3	1:F:180:PHE:CE2	2.48	0.49
1:C:365:ASP:OD1	1:D:70:GLY:HA3	2.13	0.49
1:C:392:ALA:N	1:C:393:PRO:CD	2.76	0.49
1:E:131:SER:HB3	1:E:161:VAL:HG13	1.95	0.49
1:A:38:ALA:HA	1:A:391:GLY:HA3	1.95	0.49
1:C:241:THR:CG2	1:C:244:LLP:H5'2	2.43	0.49
1:B:218:HIS:HD2	1:B:244:LLP:O3	1.96	0.48
1:A:200:ARG:HD2	1:A:200:ARG:HA	1.50	0.48
1:A:147:ILE:HD12	1:B:281:PHE:CZ	2.48	0.48
1:B:419:THR:HG23	1:B:433:PHE:HZ	1.78	0.48
1:E:241:THR:CG2	1:E:244:LLP:HG2	2.42	0.48
1:A:19:ILE:O	1:A:23:ILE:HG13	2.12	0.48
1:A:81:LEU:HD21	1:B:18:GLU:HG2	1.95	0.48
1:F:218:HIS:HB3	1:F:344:HIS:CE1	2.49	0.48
1:E:191:ALA:CB	1:E:374:ASN:HD22	2.26	0.48

Continued on next page...

Continued from previous page...

Atom-1	Atom-2	Interatomic distance (Å)	Clash overlap (Å)
1:E:292:HIS:HB3	1:E:294:HIS:CE1	2.48	0.48
1:A:51:LEU:O	1:A:294:HIS:HB2	2.14	0.48
1:C:202:ARG:HB2	1:C:234:TYR:HB3	1.96	0.47
1:E:392:ALA:N	1:E:393:PRO:CD	2.77	0.47
1:C:86:ALA:HB3	1:C:99:VAL:HG11	1.96	0.47
1:E:34:ILE:HA	1:E:395:MET:CE	2.44	0.47
1:F:22:LEU:HD23	1:F:22:LEU:HA	1.65	0.47
1:C:113:ALA:O	1:C:117:VAL:HG22	2.13	0.47
1:E:470:LYS:HE3	1:E:470:LYS:HB3	1.70	0.47
1:F:125:MET:HE1	1:F:177:ALA:CA	2.44	0.47
1:A:7:TRP:CH2	1:B:247:ARG:HD2	2.49	0.47
1:E:284:PHE:CD1	1:E:285:PRO:HA	2.50	0.47
1:C:124:ILE:O	1:C:156:SER:HA	2.15	0.47
1:A:37:ILE:HG12	1:A:370:THR:HG22	1.96	0.47
1:D:348:TRP:CH2	1:D:416:VAL:HG21	2.50	0.47
1:D:64:PRO:HD2	1:D:83:ARG:HH12	1.80	0.47
1:A:236:ASP:O	1:A:257:ARG:HG3	2.14	0.47
1:B:178:LEU:O	1:B:181:ARG:HD3	2.14	0.46
1:C:348:TRP:HB3	1:C:388:VAL:CG2	2.45	0.46
1:D:349:ASP:HA	1:D:376:VAL:HG11	1.97	0.46
1:A:131:SER:HB3	1:A:161:VAL:HG13	1.98	0.46
1:A:218:HIS:HD2	1:A:244:LLP:O3	1.97	0.46
1:E:112:ALA:HB2	1:E:287:LEU:HD23	1.97	0.46
1:A:147:ILE:HD12	1:B:281:PHE:HZ	1.81	0.46
1:C:34:ILE:HG13	1:C:450:VAL:HG13	1.97	0.46
1:C:190:SER:HA	1:C:218:HIS:CD2	2.50	0.46
1:A:101:VAL:HG12	1:A:253:MET:HG2	1.98	0.46
1:A:294:HIS:CD2	1:B:51:LEU:HD21	2.51	0.46
1:F:106:GLY:CA	1:F:241:THR:HG22	2.40	0.46
1:B:242:THR:OG1	1:B:251:ALA:HB3	2.15	0.46
1:C:202:ARG:HD2	1:C:234:TYR:O	2.15	0.46
1:D:355:LEU:HD21	1:D:420:LEU:HD23	1.97	0.46
1:A:113:ALA:O	1:A:117:VAL:HG22	2.15	0.46
1:A:218:HIS:HB3	1:A:344:HIS:CE1	2.51	0.46
1:C:230:SER:O	1:C:233:GLU:HG3	2.16	0.46
1:D:355:LEU:HD22	1:D:419:THR:HG22	1.96	0.46
1:B:86:ALA:HA	1:B:303:LEU:HD22	1.98	0.46
1:E:37:ILE:CG2	1:E:372:ASN:HD21	2.22	0.45
1:B:100:ASN:OD1	1:B:102:GLN:HG3	2.17	0.45
1:C:281:PHE:HZ	1:D:147:ILE:HD12	1.81	0.45
1:D:306:ALA:HA	1:D:311:PHE:CG	2.51	0.45

Continued on next page...

Continued from previous page...

Atom-1	Atom-2	Interatomic distance (Å)	Clash overlap (Å)
1:B:464:VAL:HG13	1:B:467:MET:HE1	1.98	0.45
1:D:20:HIS:O	1:D:24:GLU:HG2	2.16	0.45
1:F:202:ARG:HB2	1:F:234:TYR:HB3	1.97	0.45
1:A:292:HIS:HB3	1:A:294:HIS:CE1	2.52	0.45
1:C:167:TYR:CE2	1:C:194:ARG:HG3	2.52	0.45
1:E:216:MET:HG3	1:E:220:SER:HB3	1.97	0.45
1:F:273:TYR:CD2	1:F:275:PHE:HE2	2.28	0.45
1:A:281:PHE:CE2	1:B:147:ILE:HD12	2.52	0.45
1:B:332:LYS:HG2	1:B:413:HIS:CD2	2.51	0.45
1:F:112:ALA:HB2	1:F:287:LEU:HD23	1.98	0.45
1:A:345:LEU:HD12	1:A:345:LEU:C	2.42	0.45
1:C:284:PHE:HD2	1:C:288:GLN:O	2.00	0.45
1:D:123:ARG:HB3	1:D:180:PHE:CE2	2.52	0.45
1:E:113:ALA:O	1:E:117:VAL:HG22	2.18	0.44
1:E:126:GLY:O	1:E:158:PRO:HA	2.18	0.44
1:F:102:GLN:N	1:F:103:PRO:CD	2.81	0.44
1:B:190:SER:HA	1:B:218:HIS:CD2	2.52	0.44
1:B:401:VAL:HG22	1:B:402:GLU:OE1	2.17	0.44
1:D:35:GLU:HG3	1:D:42:PHE:HZ	1.82	0.44
1:E:200:ARG:HA	1:E:200:ARG:HD2	1.80	0.44
1:B:179:ASP:HB3	1:D:157:LEU:HD11	1.99	0.44
1:C:126:GLY:HA3	1:C:137:HIS:HB3	1.99	0.44
1:C:26:GLU:HG3	1:C:30:GLN:NE2	2.32	0.44
1:D:50:ALA:HB3	1:D:298:ALA:HA	1.99	0.44
1:D:86:ALA:HB3	1:D:99:VAL:HG11	1.99	0.44
1:A:292:HIS:HE1	1:B:104:TYR:O	2.01	0.44
1:B:19:ILE:O	1:B:23:ILE:HG13	2.18	0.44
1:B:50:ALA:HB3	1:B:298:ALA:HA	2.00	0.44
1:D:347:LEU:HD11	1:D:374:ASN:HB3	1.99	0.44
1:F:105:SER:O	1:F:252:GLY:HA3	2.17	0.44
1:A:284:PHE:CD1	1:A:285:PRO:HA	2.53	0.44
1:F:147:ILE:HG22	1:F:148:SER:N	2.33	0.44
1:A:311:PHE:O	1:A:314:TYR:HB3	2.18	0.44
1:B:86:ALA:HB3	1:B:99:VAL:HG11	2.00	0.44
1:C:99:VAL:HG21	1:C:253:MET:HE2	2.00	0.43
1:C:254:ILE:HG21	1:C:279:ILE:HD13	1.99	0.43
1:C:395:MET:HB2	1:C:405:PHE:CZ	2.53	0.43
1:D:59:TYR:HA	2:D:528:HOH:O	2.18	0.43
1:F:242:THR:OG1	1:F:251:ALA:HB3	2.17	0.43
1:E:123:ARG:HB3	1:E:180:PHE:CE2	2.53	0.43
1:F:4:VAL:H	1:F:4:VAL:HG12	1.49	0.43

Continued on next page...

Continued from previous page...

Atom-1	Atom-2	Interatomic distance (Å)	Clash overlap (Å)
1:F:218:HIS:HA	1:F:244:LLP:HD3	2.00	0.43
1:B:113:ALA:O	1:B:117:VAL:HG22	2.18	0.43
1:C:319:LYS:HE3	1:C:319:LYS:HB3	1.72	0.43
1:F:453:PHE:CE1	1:F:457:PHE:CE2	3.06	0.43
1:B:132:GLY:HA2	1:B:191:ALA:HB3	2.00	0.43
1:D:363:LEU:HD12	1:D:415:ALA:HB1	2.00	0.43
1:F:51:LEU:O	1:F:294:HIS:HB2	2.18	0.43
1:C:42:PHE:HB3	1:C:460:PRO:HG2	2.01	0.43
1:C:328:TYR:CZ	1:C:332:LYS:HE2	2.54	0.43
1:A:197:ASP:CG	1:A:200:ARG:HB2	2.44	0.43
1:D:139:TYR:HA	2:D:546:HOH:O	2.19	0.43
1:C:222:LEU:HD23	1:C:315:ALA:HB1	2.01	0.42
1:D:218:HIS:CD2	1:D:244:LLP:O3	2.72	0.42
1:F:140:TYR:HE2	1:F:156:SER:O	2.02	0.42
1:F:243:HIS:HB3	1:F:249:PRO:C	2.44	0.42
1:F:243:HIS:ND1	1:F:243:HIS:N	2.67	0.42
1:C:86:ALA:CB	1:C:253:MET:HE1	2.49	0.42
1:D:218:HIS:HB3	1:D:344:HIS:CE1	2.54	0.42
1:D:392:ALA:N	1:D:393:PRO:CD	2.83	0.42
1:A:58:LYS:HG2	1:A:75:ILE:HG13	2.01	0.42
1:A:129:LEU:HD22	1:A:139:TYR:CD1	2.55	0.42
1:A:374:ASN:HD22	1:A:375:ALA:N	2.07	0.42
1:C:241:THR:HB	1:C:243:HIS:CE1	2.54	0.42
1:C:347:LEU:HD11	1:C:374:ASN:HB3	2.00	0.42
1:A:411:PHE:HE1	1:A:449:ASP:HB3	1.84	0.42
1:C:50:ALA:HB3	1:C:298:ALA:HA	2.02	0.42
1:E:83:ARG:O	1:E:86:ALA:HB3	2.20	0.42
1:E:101:VAL:HG12	1:E:253:MET:HE3	2.01	0.42
1:A:186:ILE:HD13	1:A:186:ILE:HG21	1.74	0.42
1:A:194:ARG:HD3	1:A:194:ARG:HA	1.83	0.42
1:B:200:ARG:HD2	1:B:200:ARG:HA	1.66	0.42
1:E:132:GLY:HA2	1:E:191:ALA:HB3	2.01	0.42
1:F:104:TYR:N	1:F:104:TYR:CD2	2.87	0.42
1:B:36:LEU:HD12	1:B:369:ILE:HG23	2.02	0.42
1:D:216:MET:HG3	1:D:220:SER:HB3	2.02	0.42
1:E:86:ALA:CB	1:E:99:VAL:HG11	2.49	0.42
1:E:355:LEU:HD11	1:E:420:LEU:HG	2.00	0.42
1:B:227:GLU:HG3	1:B:319:LYS:HD3	2.00	0.42
1:C:216:MET:HG2	1:C:240:THR:HB	2.00	0.42
1:D:63:MET:HB3	1:D:63:MET:HE3	1.78	0.42
1:D:187:CYS:HB2	1:D:196:TRP:CE3	2.54	0.42

Continued on next page...

Continued from previous page...

Atom-1	Atom-2	Interatomic distance (Å)	Clash overlap (Å)
1:A:191:ALA:HB2	1:A:374:ASN:OD1	2.20	0.42
1:B:127:LEU:HD21	1:B:131:SER:O	2.20	0.42
1:A:349:ASP:OD1	1:A:351:ARG:HB2	2.20	0.42
1:A:401:VAL:HG22	1:A:402:GLU:H	1.84	0.42
1:F:243:HIS:HB3	1:F:249:PRO:O	2.20	0.42
1:A:12:LEU:HD12	1:A:12:LEU:O	2.20	0.41
1:A:22:LEU:HB3	1:B:78:ILE:HD11	2.02	0.41
1:B:102:GLN:N	1:B:103:PRO:CD	2.83	0.41
1:B:463:LEU:HD23	1:B:463:LEU:HA	1.72	0.41
1:A:160:LYS:HE3	1:A:176:LYS:NZ	2.34	0.41
1:E:242:THR:OG1	1:E:251:ALA:HB3	2.20	0.41
1:A:63:MET:HE1	1:A:100:ASN:HD21	1.84	0.41
1:C:128:ASP:HB2	1:C:158:PRO:HB2	2.02	0.41
1:D:68:TYR:CE2	1:D:284:PHE:HZ	2.38	0.41
1:B:242:THR:HB	1:B:299:LEU:HD13	2.02	0.41
1:B:392:ALA:N	1:B:393:PRO:CD	2.83	0.41
1:F:60:SER:O	1:F:291:PRO:HD2	2.20	0.41
1:A:348:TRP:CH2	1:A:416:VAL:HG21	2.55	0.41
1:C:285:PRO:HB2	1:D:135:LEU:CD1	2.51	0.41
1:D:124:ILE:O	1:D:156:SER:HA	2.20	0.41
1:C:326:GLY:HA2	1:C:336:LEU:HD11	2.02	0.41
1:D:113:ALA:O	1:D:117:VAL:HG22	2.21	0.41
1:A:285:PRO:HB2	1:B:135:LEU:HD13	2.02	0.41
1:A:392:ALA:N	1:A:393:PRO:CD	2.84	0.41
1:B:202:ARG:HH22	1:B:236:ASP:CG	2.29	0.41
1:C:101:VAL:HG12	1:C:253:MET:HE3	2.02	0.41
1:C:102:GLN:N	1:C:103:PRO:CD	2.84	0.41
1:D:261:LYS:HA	1:D:273:TYR:CE2	2.56	0.41
1:A:319:LYS:HB3	1:A:319:LYS:HE2	1.81	0.41
1:B:22:LEU:HD23	1:B:22:LEU:HA	1.92	0.41
1:B:123:ARG:HG2	1:B:180:PHE:CZ	2.56	0.41
1:B:256:TYR:HE1	1:B:258:LYS:HD3	1.86	0.41
1:C:135:LEU:CD1	1:D:285:PRO:HB2	2.51	0.41
1:E:102:GLN:HB2	1:E:283:VAL:HG11	2.02	0.41
1:E:134:HIS:CD2	1:E:135:LEU:H	2.39	0.41
1:F:53:SER:OG	1:F:55:LEU:HD23	2.21	0.41
1:D:202:ARG:HB2	1:D:234:TYR:HB3	2.02	0.41
1:A:29:ARG:HB2	1:B:74:TYR:HE2	1.86	0.40
1:E:413:HIS:ND1	1:E:413:HIS:C	2.79	0.40
1:F:45:PHE:N	1:F:461:GLY:HA2	2.35	0.40
1:A:304:LYS:HE2	1:B:15:VAL:O	2.21	0.40

Continued on next page...

Continued from previous page...

Atom-1	Atom-2	Interatomic distance (Å)	Clash overlap (Å)
1:B:31:CYS:HB3	1:B:459:MET:HE2	2.02	0.40
1:B:178:LEU:HD23	1:B:178:LEU:HA	1.89	0.40
1:A:25:LYS:HE2	1:B:74:TYR:CE1	2.57	0.40
1:A:236:ASP:HB3	1:A:275:PHE:CE2	2.56	0.40
1:D:242:THR:HG22	1:D:253:MET:HE2	2.03	0.40
1:F:184:LEU:HD12	1:F:211:LEU:O	2.22	0.40
1:A:157:LEU:HA	1:A:158:PRO:HD3	1.98	0.40
1:A:458:ASP:HB3	1:B:4:VAL:HG11	2.03	0.40
1:C:367:CYS:HA	1:C:447:LYS:HB2	2.02	0.40
1:D:103:PRO:HA	1:D:288:GLN:OE1	2.20	0.40
1:D:367:CYS:HA	1:D:447:LYS:HB2	2.04	0.40
1:F:243:HIS:CD2	1:F:250:ARG:HA	2.56	0.40
1:A:392:ALA:N	1:A:393:PRO:HD3	2.37	0.40
1:C:147:ILE:HD12	1:D:281:PHE:CZ	2.56	0.40
1:F:139:TYR:HD2	1:F:147:ILE:HB	1.86	0.40

There are no symmetry-related clashes.

5.3 Torsion angles [i](#)

5.3.1 Protein backbone [i](#)

In the following table, the Percentiles column shows the percent Ramachandran outliers of the chain as a percentile score with respect to all X-ray entries followed by that with respect to entries of similar resolution.

The Analysed column shows the number of residues for which the backbone conformation was analysed, and the total number of residues.

Mol	Chain	Analysed	Favoured	Allowed	Outliers	Percentiles	
1	A	455/492 (92%)	435 (96%)	20 (4%)	0	100	100
1	B	450/492 (92%)	432 (96%)	18 (4%)	0	100	100
1	C	453/492 (92%)	433 (96%)	20 (4%)	0	100	100
1	D	456/492 (93%)	433 (95%)	23 (5%)	0	100	100
1	E	454/492 (92%)	436 (96%)	18 (4%)	0	100	100
1	F	441/492 (90%)	410 (93%)	22 (5%)	9 (2%)	6	4
All	All	2709/2952 (92%)	2579 (95%)	121 (4%)	9 (0%)	37	45

All (9) Ramachandran outliers are listed below:

Mol	Chain	Res	Type
1	F	94	ALA
1	F	429	LEU
1	F	430	LEU
1	F	432	ASP
1	F	376	VAL
1	F	441	LYS
1	F	93	ASP
1	F	378	GLY
1	F	18	GLU

5.3.2 Protein sidechains [i](#)

In the following table, the Percentiles column shows the percent sidechain outliers of the chain as a percentile score with respect to all X-ray entries followed by that with respect to entries of similar resolution.

The Analysed column shows the number of residues for which the sidechain conformation was analysed, and the total number of residues.

Mol	Chain	Analysed	Rotameric	Outliers	Percentiles	
1	A	327/403 (81%)	317 (97%)	10 (3%)	35	49
1	B	330/403 (82%)	321 (97%)	9 (3%)	40	54
1	C	337/403 (84%)	331 (98%)	6 (2%)	54	68
1	D	328/403 (81%)	325 (99%)	3 (1%)	75	86
1	E	318/403 (79%)	310 (98%)	8 (2%)	42	57
1	F	217/403 (54%)	209 (96%)	8 (4%)	29	41
All	All	1857/2418 (77%)	1813 (98%)	44 (2%)	44	59

All (44) residues with a non-rotameric sidechain are listed below:

Mol	Chain	Res	Type
1	A	28	ARG
1	A	81	LEU
1	A	146	LYS
1	A	200	ARG
1	A	218	HIS
1	A	351	ARG
1	A	372	ASN
1	A	374	ASN
1	A	390	ILE
1	A	397	SER

Continued on next page...

Continued from previous page...

Mol	Chain	Res	Type
1	B	19	ILE
1	B	59	TYR
1	B	129	LEU
1	B	173	LEU
1	B	183	LYS
1	B	227	GLU
1	B	338	THR
1	B	397	SER
1	B	416	VAL
1	C	12	LEU
1	C	59	TYR
1	C	87	LEU
1	C	241	THR
1	C	319	LYS
1	C	374	ASN
1	D	190	SER
1	D	369	ILE
1	D	376	VAL
1	E	40	GLU
1	E	60	SER
1	E	241	THR
1	E	258	LYS
1	E	372	ASN
1	E	376	VAL
1	E	464	VAL
1	E	470	LYS
1	F	4	VAL
1	F	84	SER
1	F	218	HIS
1	F	222	LEU
1	F	338	THR
1	F	345	LEU
1	F	356	THR
1	F	401	VAL

Sometimes sidechains can be flipped to improve hydrogen bonding and reduce clashes. All (26) such sidechains are listed below:

Mol	Chain	Res	Type
1	A	137	HIS
1	A	295	GLN
1	A	372	ASN
1	A	374	ASN

Continued on next page...

Continued from previous page...

Mol	Chain	Res	Type
1	A	434	ASN
1	B	321	ASN
1	B	372	ASN
1	C	372	ASN
1	C	407	GLN
1	C	434	ASN
1	C	440	ASN
1	D	9	ASN
1	D	72	ASN
1	D	226	GLN
1	D	295	GLN
1	D	407	GLN
1	D	413	HIS
1	E	77	GLN
1	E	293	ASN
1	E	295	GLN
1	E	321	ASN
1	E	372	ASN
1	E	374	ASN
1	E	407	GLN
1	F	226	GLN
1	F	288	GLN

5.3.3 RNA [i](#)

There are no RNA molecules in this entry.

5.4 Non-standard residues in protein, DNA, RNA chains [i](#)

6 non-standard protein/DNA/RNA residues are modelled in this entry.

In the following table, the Counts columns list the number of bonds (or angles) for which Mogul statistics could be retrieved, the number of bonds (or angles) that are observed in the model and the number of bonds (or angles) that are defined in the Chemical Component Dictionary. The Link column lists molecule types, if any, to which the group is linked. The Z score for a bond length (or angle) is the number of standard deviations the observed value is removed from the expected value. A bond length (or angle) with $|Z| > 2$ is considered an outlier worth inspection. RMSZ is the root-mean-square of all Z scores of the bond lengths (or angles).

Mol	Type	Chain	Res	Link	Bond lengths			Bond angles		
					Counts	RMSZ	# Z > 2	Counts	RMSZ	# Z > 2
1	LLP	C	244	1	23,24,25	1.08	1 (4%)	25,32,34	1.63	4 (16%)

Mol	Type	Chain	Res	Link	Bond lengths			Bond angles		
					Counts	RMSZ	# Z > 2	Counts	RMSZ	# Z > 2
1	LLP	D	244	1	23,24,25	1.17	3 (13%)	25,32,34	1.62	8 (32%)
1	LLP	B	244	1	23,24,25	1.16	2 (8%)	25,32,34	2.01	8 (32%)
1	LLP	E	244	1	23,24,25	1.17	2 (8%)	25,32,34	1.73	4 (16%)
1	LLP	F	244	1	23,24,25	1.17	1 (4%)	25,32,34	1.43	5 (20%)
1	LLP	A	244	1	23,24,25	1.14	1 (4%)	25,32,34	1.12	3 (12%)

In the following table, the Chirals column lists the number of chiral outliers, the number of chiral centers analysed, the number of these observed in the model and the number defined in the Chemical Component Dictionary. Similar counts are reported in the Torsion and Rings columns. '-' means no outliers of that kind were identified.

Mol	Type	Chain	Res	Link	Chirals	Torsions	Rings
1	LLP	C	244	1	-	13/16/17/19	0/1/1/1
1	LLP	D	244	1	-	11/16/17/19	0/1/1/1
1	LLP	B	244	1	-	8/16/17/19	0/1/1/1
1	LLP	E	244	1	-	11/16/17/19	0/1/1/1
1	LLP	F	244	1	-	10/16/17/19	0/1/1/1
1	LLP	A	244	1	-	11/16/17/19	0/1/1/1

All (10) bond length outliers are listed below:

Mol	Chain	Res	Type	Atoms	Z	Observed(Å)	Ideal(Å)
1	F	244	LLP	P-OP4	4.37	1.74	1.60
1	E	244	LLP	P-OP4	3.94	1.72	1.60
1	D	244	LLP	P-OP4	3.70	1.72	1.60
1	A	244	LLP	P-OP4	3.66	1.71	1.60
1	C	244	LLP	P-OP4	3.54	1.71	1.60
1	B	244	LLP	P-OP4	3.42	1.71	1.60
1	B	244	LLP	O3-C3	-2.25	1.31	1.36
1	D	244	LLP	OP4-C5'	-2.17	1.36	1.44
1	D	244	LLP	O3-C3	-2.06	1.32	1.36
1	E	244	LLP	O3-C3	-2.03	1.32	1.36

All (32) bond angle outliers are listed below:

Mol	Chain	Res	Type	Atoms	Z	Observed(°)	Ideal(°)
1	B	244	LLP	C5-C4-C4'	4.68	128.68	121.47
1	B	244	LLP	C4-C3-C2	4.49	122.67	120.14
1	E	244	LLP	C5-C4-C4'	3.84	127.39	121.47

Continued on next page...

Continued from previous page...

Mol	Chain	Res	Type	Atoms	Z	Observed(°)	Ideal(°)
1	E	244	LLP	OP4-C5'-C5	3.66	116.22	109.36
1	E	244	LLP	C3-C4-C4'	-3.62	113.87	120.40
1	C	244	LLP	OP3-P-OP2	3.61	121.35	107.80
1	F	244	LLP	C5'-C5-C6	3.60	125.23	119.36
1	D	244	LLP	OP3-P-OP2	3.59	121.26	107.80
1	C	244	LLP	OP4-C5'-C5	3.37	115.66	109.36
1	F	244	LLP	OP4-C5'-C5	3.35	115.64	109.36
1	B	244	LLP	C3-C4-C4'	-3.03	114.92	120.40
1	F	244	LLP	C2'-C2-C3	-2.87	117.44	120.80
1	C	244	LLP	C5-C4-C4'	2.85	125.86	121.47
1	C	244	LLP	C5'-C5-C6	-2.82	114.77	119.36
1	B	244	LLP	OP2-P-OP4	-2.76	99.48	106.67
1	D	244	LLP	C2'-C2-C3	-2.74	117.59	120.80
1	B	244	LLP	OP3-P-OP2	2.74	118.06	107.80
1	B	244	LLP	C3-C4-C5	-2.65	116.15	118.28
1	D	244	LLP	OP4-P-OP1	-2.64	99.30	106.44
1	D	244	LLP	OP2-P-OP4	-2.62	99.83	106.67
1	E	244	LLP	OP3-P-OP2	2.54	117.33	107.80
1	D	244	LLP	C5'-C5-C6	2.47	123.39	119.36
1	B	244	LLP	OP4-P-OP1	-2.47	99.76	106.44
1	A	244	LLP	OP3-P-OP2	2.30	116.43	107.80
1	F	244	LLP	OP3-P-OP2	2.29	116.38	107.80
1	D	244	LLP	C4-C3-C2	2.24	121.40	120.14
1	D	244	LLP	C2'-C2-N1	2.23	121.84	117.64
1	D	244	LLP	C3-C4-C5	-2.23	116.49	118.28
1	A	244	LLP	C5-C4-C4'	2.22	124.89	121.47
1	F	244	LLP	C2'-C2-N1	2.14	121.68	117.64
1	B	244	LLP	CE-NZ-C4'	2.13	125.55	118.72
1	A	244	LLP	OP4-P-OP1	-2.07	100.85	106.44

There are no chirality outliers.

All (64) torsion outliers are listed below:

Mol	Chain	Res	Type	Atoms
1	A	244	LLP	C4-C4'-NZ-CE
1	A	244	LLP	C5'-OP4-P-OP1
1	A	244	LLP	C5'-OP4-P-OP2
1	A	244	LLP	C5'-OP4-P-OP3
1	A	244	LLP	O-C-CA-CB
1	B	244	LLP	C4-C4'-NZ-CE
1	B	244	LLP	O-C-CA-CB
1	C	244	LLP	C5-C4-C4'-NZ

Continued on next page...

Continued from previous page...

Mol	Chain	Res	Type	Atoms
1	C	244	LLP	C4-C4'-NZ-CE
1	C	244	LLP	C4-C5-C5'-OP4
1	C	244	LLP	C6-C5-C5'-OP4
1	C	244	LLP	C5'-OP4-P-OP1
1	C	244	LLP	O-C-CA-CB
1	D	244	LLP	C4-C4'-NZ-CE
1	D	244	LLP	C5'-OP4-P-OP1
1	D	244	LLP	C5'-OP4-P-OP2
1	D	244	LLP	C5'-OP4-P-OP3
1	D	244	LLP	O-C-CA-CB
1	E	244	LLP	C5-C4-C4'-NZ
1	E	244	LLP	C4-C4'-NZ-CE
1	E	244	LLP	C5'-OP4-P-OP1
1	E	244	LLP	C5'-OP4-P-OP2
1	E	244	LLP	C5'-OP4-P-OP3
1	E	244	LLP	O-C-CA-CB
1	F	244	LLP	C4-C4'-NZ-CE
1	F	244	LLP	C5'-OP4-P-OP2
1	F	244	LLP	C5'-OP4-P-OP3
1	F	244	LLP	O-C-CA-CB
1	A	244	LLP	CG-CD-CE-NZ
1	B	244	LLP	CG-CD-CE-NZ
1	C	244	LLP	CG-CD-CE-NZ
1	D	244	LLP	CG-CD-CE-NZ
1	E	244	LLP	CG-CD-CE-NZ
1	F	244	LLP	CG-CD-CE-NZ
1	B	244	LLP	C3-C4-C4'-NZ
1	D	244	LLP	C3-C4-C4'-NZ
1	F	244	LLP	C3-C4-C4'-NZ
1	D	244	LLP	C5-C4-C4'-NZ
1	A	244	LLP	C3-C4-C4'-NZ
1	C	244	LLP	C3-C4-C4'-NZ
1	E	244	LLP	C3-C4-C4'-NZ
1	F	244	LLP	C5'-OP4-P-OP1
1	A	244	LLP	C5-C4-C4'-NZ
1	B	244	LLP	C5-C4-C4'-NZ
1	E	244	LLP	CE-CD-CG-CB
1	A	244	LLP	CE-CD-CG-CB
1	B	244	LLP	CE-CD-CG-CB
1	C	244	LLP	CE-CD-CG-CB
1	A	244	LLP	CD-CE-NZ-C4'
1	B	244	LLP	CD-CE-NZ-C4'

Continued on next page...

Continued from previous page...

Mol	Chain	Res	Type	Atoms
1	F	244	LLP	CE-CD-CG-CB
1	D	244	LLP	CE-CD-CG-CB
1	C	244	LLP	CD-CE-NZ-C4'
1	D	244	LLP	CD-CE-NZ-C4'
1	F	244	LLP	CA-CB-CG-CD
1	E	244	LLP	CD-CE-NZ-C4'
1	F	244	LLP	CD-CE-NZ-C4'
1	B	244	LLP	CA-CB-CG-CD
1	C	244	LLP	C5'-OP4-P-OP2
1	C	244	LLP	C5'-OP4-P-OP3
1	E	244	LLP	CA-CB-CG-CD
1	C	244	LLP	CA-CB-CG-CD
1	A	244	LLP	CA-CB-CG-CD
1	D	244	LLP	CA-CB-CG-CD

There are no ring outliers.

6 monomers are involved in 15 short contacts:

Mol	Chain	Res	Type	Clashes	Symm-Clashes
1	C	244	LLP	2	0
1	D	244	LLP	2	0
1	B	244	LLP	2	0
1	E	244	LLP	3	0
1	F	244	LLP	2	0
1	A	244	LLP	4	0

5.5 Carbohydrates [i](#)

There are no oligosaccharides in this entry.

5.6 Ligand geometry [i](#)

There are no ligands in this entry.

5.7 Other polymers [i](#)

There are no such residues in this entry.

5.8 Polymer linkage issues

There are no chain breaks in this entry.

6 Fit of model and data

6.1 Protein, DNA and RNA chains

In the following table, the column labelled ‘#RSRZ> 2’ contains the number (and percentage) of RSRZ outliers, followed by percent RSRZ outliers for the chain as percentile scores relative to all X-ray entries and entries of similar resolution. The OWAB column contains the minimum, median, 95th percentile and maximum values of the occupancy-weighted average B-factor per residue. The column labelled ‘Q< 0.9’ lists the number of (and percentage) of residues with an average occupancy less than 0.9.

Mol	Chain	Analysed	<RSRZ>	#RSRZ>2	OWAB(Å ²)	Q<0.9
1	A	461/492 (93%)	1.03	62 (13%) 8 9	29, 46, 82, 118	0
1	B	458/492 (93%)	1.01	47 (10%) 13 14	26, 38, 71, 103	0
1	C	459/492 (93%)	1.07	49 (10%) 12 13	28, 44, 79, 108	0
1	D	462/492 (93%)	1.05	59 (12%) 9 9	28, 38, 76, 102	0
1	E	460/492 (93%)	1.01	65 (14%) 7 8	34, 48, 87, 110	0
1	F	449/492 (91%)	2.40	263 (58%) 0 0	53, 76, 109, 134	0
All	All	2749/2952 (93%)	1.26	545 (19%) 3 4	26, 47, 92, 134	0

All (545) RSRZ outliers are listed below:

Mol	Chain	Res	Type	RSRZ
1	F	74	TYR	9.3
1	F	460	PRO	8.4
1	F	54	ALA	8.2
1	F	240	THR	7.0
1	F	66	ASN	6.5
1	E	68	TYR	6.5
1	F	69	TYR	6.4
1	C	68	TYR	6.4
1	F	1	MET	6.2
1	A	68	TYR	6.1
1	B	381	SER	6.1
1	E	69	TYR	6.0
1	F	465	SER	5.9
1	F	7	TRP	5.9
1	F	68	TYR	5.8
1	F	251	ALA	5.8
1	F	454	SER	5.8
1	F	376	VAL	5.7
1	F	466	GLU	5.6

Continued on next page...

Continued from previous page...

Mol	Chain	Res	Type	RSRZ
1	F	399	GLY	5.4
1	F	379	ASP	5.4
1	F	59	TYR	5.3
1	F	95	GLN	5.2
1	F	255	PHE	5.1
1	D	68	TYR	5.1
1	F	377	PHE	5.1
1	E	376	VAL	5.0
1	F	4	VAL	5.0
1	F	247	ARG	5.0
1	A	438	VAL	4.9
1	F	301	VAL	4.8
1	F	464	VAL	4.8
1	F	132	GLY	4.8
1	C	190	SER	4.8
1	E	60	SER	4.7
1	E	66	ASN	4.7
1	F	81	LEU	4.6
1	F	246	LEU	4.6
1	F	360	VAL	4.6
1	F	433	PHE	4.6
1	E	61	GLU	4.5
1	F	388	VAL	4.5
1	B	436	GLY	4.4
1	F	9	ASN	4.4
1	D	376	VAL	4.4
1	C	375	ALA	4.4
1	F	313	ALA	4.4
1	E	142	SER	4.4
1	B	442	ALA	4.4
1	A	62	GLY	4.4
1	F	62	GLY	4.4
1	F	75	ILE	4.4
1	F	61	GLU	4.3
1	F	35	GLU	4.3
1	F	243	HIS	4.3
1	F	0	ASN	4.3
1	C	69	TYR	4.2
1	F	70	GLY	4.2
1	F	12	LEU	4.2
1	F	13	ALA	4.2
1	D	74	TYR	4.1

Continued on next page...

Continued from previous page...

Mol	Chain	Res	Type	RSRZ
1	F	462	PHE	4.1
1	F	83	ARG	4.1
1	F	304	LYS	4.1
1	B	-1	SER	4.1
1	F	196	TRP	4.0
1	F	16	ASP	4.0
1	F	439	ASN	4.0
1	F	374	ASN	4.0
1	B	358	ASN	3.9
1	C	376	VAL	3.9
1	E	65	GLY	3.9
1	F	17	PRO	3.9
1	F	56	THR	3.9
1	F	440	ASN	3.9
1	F	371	VAL	3.9
1	F	53	SER	3.9
1	F	458	ASP	3.9
1	F	259	GLY	3.9
1	F	11	PRO	3.8
1	C	384	ALA	3.8
1	F	291	PRO	3.8
1	F	284	PHE	3.8
1	A	60	SER	3.7
1	F	129	LEU	3.7
1	D	377	PHE	3.7
1	F	469	TYR	3.7
1	D	379	ASP	3.7
1	D	66	ASN	3.7
1	F	96	SER	3.6
1	F	242	THR	3.6
1	F	318	VAL	3.6
1	F	60	SER	3.6
1	C	437	LEU	3.6
1	A	378	GLY	3.6
1	F	275	PHE	3.6
1	F	292	HIS	3.6
1	F	51	LEU	3.6
1	F	250	ARG	3.6
1	F	351	ARG	3.6
1	F	270	ASN	3.6
1	F	340	GLY	3.6
1	F	18	GLU	3.6

Continued on next page...

Continued from previous page...

Mol	Chain	Res	Type	RSRZ
1	F	31	CYS	3.5
1	A	439	ASN	3.5
1	A	426	HIS	3.5
1	F	23	ILE	3.5
1	F	294	HIS	3.5
1	A	67	ARG	3.5
1	B	129	LEU	3.5
1	F	248	GLY	3.5
1	F	19	ILE	3.5
1	A	377	PHE	3.5
1	F	104	TYR	3.5
1	D	63	MET	3.5
1	F	303	LEU	3.4
1	F	10	THR	3.4
1	F	14	THR	3.4
1	F	47	VAL	3.4
1	F	39	SER	3.4
1	B	333	GLY	3.4
1	E	358	ASN	3.4
1	D	-1	SER	3.4
1	F	5	SER	3.4
1	C	66	ASN	3.4
1	C	439	ASN	3.4
1	F	241	THR	3.4
1	E	347	LEU	3.4
1	F	373	LYS	3.4
1	F	88	GLN	3.3
1	E	375	ALA	3.3
1	F	216	MET	3.3
1	F	34	ILE	3.3
1	F	48	ILE	3.3
1	F	28	ARG	3.3
1	B	59	TYR	3.3
1	F	82	CYS	3.3
1	A	0	ASN	3.3
1	A	379	ASP	3.3
1	E	422	ILE	3.3
1	F	405	PHE	3.3
1	C	142	SER	3.3
1	F	245	SER	3.3
1	B	0	ASN	3.3
1	F	43	THR	3.3

Continued on next page...

Continued from previous page...

Mol	Chain	Res	Type	RSRZ
1	F	78	ILE	3.3
1	F	45	PHE	3.3
1	A	63	MET	3.3
1	F	99	VAL	3.3
1	F	213	LEU	3.3
1	F	361	GLU	3.2
1	E	-1	SER	3.2
1	F	356	THR	3.2
1	D	437	LEU	3.2
1	E	363	LEU	3.2
1	F	456	LEU	3.2
1	A	132	GLY	3.2
1	F	283	VAL	3.2
1	F	450	VAL	3.2
1	A	384	ALA	3.2
1	F	89	ALA	3.2
1	C	61	GLU	3.2
1	C	62	GLY	3.2
1	F	238	VAL	3.2
1	A	422	ILE	3.2
1	A	-1	SER	3.2
1	C	284	PHE	3.2
1	F	87	LEU	3.2
1	F	133	GLY	3.2
1	F	298	ALA	3.1
1	E	63	MET	3.1
1	A	263	PRO	3.1
1	D	262	PRO	3.1
1	F	295	GLN	3.1
1	F	397	SER	3.1
1	F	428	LYS	3.1
1	F	219	THR	3.1
1	F	370	THR	3.1
1	F	453	PHE	3.1
1	F	134	HIS	3.1
1	B	269	GLU	3.1
1	F	392	ALA	3.1
1	E	264	LYS	3.1
1	A	437	LEU	3.1
1	E	67	ARG	3.1
1	F	92	LEU	3.0
1	E	433	PHE	3.0

Continued on next page...

Continued from previous page...

Mol	Chain	Res	Type	RSRZ
1	C	356	THR	3.0
1	E	423	GLN	3.0
1	C	133	GLY	3.0
1	F	325	LEU	3.0
1	D	284	PHE	3.0
1	E	272	VAL	3.0
1	F	455	ALA	3.0
1	B	69	TYR	3.0
1	F	461	GLY	3.0
1	D	358	ASN	3.0
1	F	375	ALA	3.0
1	C	263	PRO	3.0
1	B	429	LEU	3.0
1	F	212	LEU	3.0
1	F	299	LEU	3.0
1	F	366	LEU	3.0
1	F	57	ASN	3.0
1	F	416	VAL	3.0
1	F	94	ALA	3.0
1	F	191	ALA	3.0
1	D	419	THR	2.9
1	E	425	GLU	2.9
1	F	73	GLU	2.9
1	F	437	LEU	2.9
1	F	72	ASN	2.9
1	F	27	LYS	2.9
1	F	58	LYS	2.9
1	F	364	CYS	2.9
1	A	134	HIS	2.9
1	C	426	HIS	2.9
1	E	164	THR	2.9
1	D	270	ASN	2.9
1	E	32	ARG	2.9
1	F	288	GLN	2.9
1	F	401	VAL	2.9
1	B	375	ALA	2.9
1	A	356	THR	2.9
1	F	8	GLY	2.9
1	B	270	ASN	2.9
1	A	388	VAL	2.9
1	F	310	GLY	2.9
1	F	30	GLN	2.9

Continued on next page...

Continued from previous page...

Mol	Chain	Res	Type	RSRZ
1	B	377	PHE	2.8
1	B	458	ASP	2.8
1	F	2	ASP	2.8
1	B	352	PRO	2.8
1	C	262	PRO	2.8
1	C	438	VAL	2.8
1	F	187	CYS	2.8
1	A	387	GLY	2.8
1	E	333	GLY	2.8
1	A	135	LEU	2.8
1	F	22	LEU	2.8
1	F	355	LEU	2.8
1	E	434	ASN	2.8
1	F	408	ILE	2.8
1	B	438	VAL	2.8
1	C	272	VAL	2.8
1	F	393	PRO	2.8
1	F	52	GLY	2.8
1	E	369	ILE	2.8
1	A	69	TYR	2.8
1	F	449	ASP	2.8
1	C	275	PHE	2.8
1	E	269	GLU	2.8
1	F	49	GLU	2.8
1	F	348	TRP	2.8
1	F	350	LEU	2.8
1	E	439	ASN	2.8
1	F	328	TYR	2.8
1	F	311	PHE	2.8
1	A	371	VAL	2.8
1	C	65	GLY	2.8
1	D	434	ASN	2.8
1	D	439	ASN	2.8
1	F	321	ASN	2.8
1	F	358	ASN	2.8
1	F	372	ASN	2.8
1	F	37	ILE	2.7
1	F	185	ILE	2.7
1	F	296	ILE	2.7
1	E	274	ASP	2.7
1	B	281	PHE	2.7
1	F	334	TYR	2.7

Continued on next page...

Continued from previous page...

Mol	Chain	Res	Type	RSRZ
1	F	6	VAL	2.7
1	F	225	ALA	2.7
1	A	137	HIS	2.7
1	B	437	LEU	2.7
1	C	430	LEU	2.7
1	C	432	ASP	2.7
1	C	273	TYR	2.7
1	E	348	TRP	2.7
1	F	409	GLY	2.7
1	F	463	LEU	2.7
1	A	262	PRO	2.7
1	F	167	TYR	2.7
1	B	384	ALA	2.7
1	D	271	ALA	2.7
1	F	357	GLY	2.7
1	C	374	ASN	2.7
1	F	26	GLU	2.7
1	D	283	VAL	2.7
1	C	431	LYS	2.7
1	D	469	TYR	2.7
1	C	63	MET	2.6
1	B	60	SER	2.6
1	F	188	GLY	2.6
1	A	61	GLU	2.6
1	A	348	TRP	2.6
1	F	97	TRP	2.6
1	F	445	ASP	2.6
1	F	218	HIS	2.6
1	F	362	LYS	2.6
1	A	133	GLY	2.6
1	B	54	ALA	2.6
1	F	315	ALA	2.6
1	D	273	TYR	2.6
1	F	459	MET	2.6
1	F	235	CYS	2.6
1	B	426	HIS	2.6
1	F	42	PHE	2.6
1	F	391	GLY	2.6
1	A	420	LEU	2.6
1	E	430	LEU	2.6
1	E	437	LEU	2.6
1	F	363	LEU	2.6

Continued on next page...

Continued from previous page...

Mol	Chain	Res	Type	RSRZ
1	A	434	ASN	2.6
1	B	3	PRO	2.6
1	B	279	ILE	2.6
1	A	191	ALA	2.5
1	E	191	ALA	2.5
1	A	165	THR	2.5
1	A	353	LEU	2.5
1	E	418	LEU	2.5
1	D	104	TYR	2.5
1	A	39	SER	2.5
1	B	348	TRP	2.5
1	F	21	ASP	2.5
1	A	427	GLY	2.5
1	E	387	GLY	2.5
1	D	384	ALA	2.5
1	F	228	VAL	2.5
1	F	394	ALA	2.5
1	F	442	ALA	2.5
1	B	430	LEU	2.5
1	D	373	LYS	2.5
1	F	470	LYS	2.5
1	D	234	TYR	2.5
1	F	335	SER	2.5
1	A	425	GLU	2.5
1	F	106	GLY	2.5
1	A	375	ALA	2.5
1	B	306	ALA	2.5
1	D	272	VAL	2.5
1	F	38	ALA	2.5
1	F	306	ALA	2.5
1	E	374	ASN	2.5
1	F	249	PRO	2.5
1	D	23	ILE	2.5
1	F	432	ASP	2.5
1	B	455	ALA	2.5
1	C	271	ALA	2.5
1	F	86	ALA	2.5
1	F	224	ALA	2.5
1	E	270	ASN	2.5
1	F	91	HIS	2.5
1	F	103	PRO	2.5
1	D	59	TYR	2.4

Continued on next page...

Continued from previous page...

Mol	Chain	Res	Type	RSRZ
1	E	59	TYR	2.4
1	F	124	ILE	2.4
1	D	221	GLY	2.4
1	B	217	ALA	2.4
1	C	87	LEU	2.4
1	F	434	ASN	2.4
1	F	164	THR	2.4
1	F	369	ILE	2.4
1	A	373	LYS	2.4
1	A	138	GLY	2.4
1	E	70	GLY	2.4
1	E	31	CYS	2.4
1	F	430	LEU	2.4
1	F	457	PHE	2.4
1	F	130	PRO	2.4
1	A	428	LYS	2.4
1	F	273	TYR	2.4
1	F	20	HIS	2.4
1	F	112	ALA	2.4
1	F	113	ALA	2.4
1	F	300	ALA	2.4
1	F	412	LEU	2.4
1	A	72	ASN	2.4
1	A	376	VAL	2.4
1	D	275	PHE	2.4
1	C	268	PRO	2.4
1	F	105	SER	2.4
1	F	378	GLY	2.4
1	D	375	ALA	2.4
1	F	100	ASN	2.4
1	F	429	LEU	2.4
1	B	284	PHE	2.3
1	C	64	PRO	2.3
1	F	309	PRO	2.3
1	D	190	SER	2.3
1	D	432	ASP	2.3
1	D	454	SER	2.3
1	E	297	GLY	2.3
1	C	358	ASN	2.3
1	D	420	LEU	2.3
1	D	430	LEU	2.3
1	F	36	LEU	2.3

Continued on next page...

Continued from previous page...

Mol	Chain	Res	Type	RSRZ
1	F	400	LEU	2.3
1	F	50	ALA	2.3
1	F	271	ALA	2.3
1	B	4	VAL	2.3
1	B	164	THR	2.3
1	C	269	GLU	2.3
1	F	136	THR	2.3
1	F	281	PHE	2.3
1	E	64	PRO	2.3
1	F	441	LYS	2.3
1	C	196	TRP	2.3
1	C	59	TYR	2.3
1	A	372	ASN	2.3
1	C	355	LEU	2.3
1	D	287	LEU	2.3
1	E	415	ALA	2.3
1	E	284	PHE	2.3
1	F	67	ARG	2.3
1	A	458	ASP	2.3
1	B	39	SER	2.3
1	D	426	HIS	2.3
1	A	166	GLY	2.3
1	A	333	GLY	2.3
1	E	62	GLY	2.3
1	C	429	LEU	2.3
1	D	118	LEU	2.3
1	F	353	LEU	2.3
1	D	109	ALA	2.3
1	F	217	ALA	2.3
1	A	149	THR	2.3
1	C	56	THR	2.3
1	F	346	VAL	2.3
1	F	214	CYS	2.3
1	E	426	HIS	2.3
1	E	365	ASP	2.3
1	F	186	ILE	2.3
1	F	236	ASP	2.3
1	F	365	ASP	2.3
1	E	33	GLY	2.3
1	E	427	GLY	2.3
1	F	435	LYS	2.2
1	E	421	GLU	2.2

Continued on next page...

Continued from previous page...

Mol	Chain	Res	Type	RSRZ
1	F	256	TYR	2.2
1	C	415	ALA	2.2
1	A	370	THR	2.2
1	D	268	PRO	2.2
1	F	3	PRO	2.2
1	F	15	VAL	2.2
1	A	281	PHE	2.2
1	E	168	ILE	2.2
1	D	62	GLY	2.2
1	D	357	GLY	2.2
1	F	166	GLY	2.2
1	D	429	LEU	2.2
1	F	198	TYR	2.2
1	A	306	ALA	2.2
1	F	302	ALA	2.2
1	F	90	PHE	2.2
1	A	445	ASP	2.2
1	C	237	ILE	2.2
1	F	443	ILE	2.2
1	E	132	GLY	2.2
1	D	127	LEU	2.2
1	F	414	ARG	2.2
1	F	418	LEU	2.2
1	F	234	TYR	2.2
1	D	54	ALA	2.2
1	D	241	THR	2.2
1	D	95	GLN	2.2
1	B	265	LYS	2.2
1	D	425	GLU	2.2
1	C	348	TRP	2.2
1	F	55	LEU	2.2
1	F	347	LEU	2.2
1	F	446	LEU	2.2
1	E	17	PRO	2.2
1	C	469	TYR	2.2
1	E	307	ALA	2.2
1	F	46	ALA	2.2
1	A	164	THR	2.2
1	D	136	THR	2.2
1	D	164	THR	2.2
1	A	161	VAL	2.2
1	E	360	VAL	2.2

Continued on next page...

Continued from previous page...

Mol	Chain	Res	Type	RSRZ
1	C	470	LYS	2.2
1	E	431	LYS	2.2
1	A	163	SER	2.1
1	B	425	GLU	2.1
1	C	427	GLY	2.1
1	E	351	ARG	2.1
1	E	355	LEU	2.1
1	E	74	TYR	2.1
1	F	322	ALA	2.1
1	F	415	ALA	2.1
1	F	341	THR	2.1
1	F	411	PHE	2.1
1	D	61	GLU	2.1
1	F	93	ASP	2.1
1	B	142	SER	2.1
1	D	188	GLY	2.1
1	F	131	SER	2.1
1	C	0	ASN	2.1
1	F	211	LEU	2.1
1	D	260	PRO	2.1
1	B	115	THR	2.1
1	B	360	VAL	2.1
1	B	371	VAL	2.1
1	B	432	ASP	2.1
1	E	29	ARG	2.1
1	A	443	ILE	2.1
1	D	254	ILE	2.1
1	A	55	LEU	2.1
1	F	108	PRO	2.1
1	D	433	PHE	2.1
1	F	172	ARG	2.1
1	F	137	HIS	2.1
1	D	350	LEU	2.1
1	E	7	TRP	2.1
1	A	86	ALA	2.1
1	B	191	ALA	2.1
1	B	320	ALA	2.1
1	D	300	ALA	2.1
1	F	342	GLU	2.0
1	E	172	ARG	2.0
1	E	438	VAL	2.0
1	F	101	VAL	2.0

Continued on next page...

Continued from previous page...

Mol	Chain	Res	Type	RSRZ
1	B	76	ASP	2.0
1	C	261	LYS	2.0
1	F	152	ILE	2.0
1	A	423	GLN	2.0
1	C	135	LEU	2.0
1	F	293	ASN	2.0
1	F	253	MET	2.0
1	A	392	ALA	2.0
1	B	40	GLU	2.0
1	E	28	ARG	2.0
1	F	257	ARG	2.0
1	C	283	VAL	2.0
1	F	71	GLY	2.0
1	A	424	LYS	2.0
1	D	142	SER	2.0
1	F	220	SER	2.0
1	E	254	ILE	2.0
1	B	366	LEU	2.0
1	D	355	LEU	2.0
1	F	127	LEU	2.0
1	F	367	CYS	2.0
1	F	395	MET	2.0

6.2 Non-standard residues in protein, DNA, RNA chains [i](#)

In the following table, the Atoms column lists the number of modelled atoms in the group and the number defined in the chemical component dictionary. The B-factors column lists the minimum, median, 95th percentile and maximum values of B factors of atoms in the group. The column labelled 'Q< 0.9' lists the number of atoms with occupancy less than 0.9.

Mol	Type	Chain	Res	Atoms	RSCC	RSR	B-factors(Å ²)	Q<0.9
1	LLP	F	244	24/25	0.81	0.21	64,78,89,91	0
1	LLP	B	244	24/25	0.87	0.15	28,33,35,36	0
1	LLP	C	244	24/25	0.88	0.14	34,42,47,47	0
1	LLP	D	244	24/25	0.91	0.13	28,36,40,41	0
1	LLP	A	244	24/25	0.91	0.15	33,43,47,48	0
1	LLP	E	244	24/25	0.92	0.14	38,45,51,51	0

6.3 Carbohydrates [i](#)

There are no oligosaccharides in this entry.

6.4 Ligands

There are no ligands in this entry.

6.5 Other polymers

There are no such residues in this entry.